

# Your Project Calculations



Project Name: MTSOLAR\_6C6AHG4B7G29

S3D Model Link:

[https://platform.skyciv.com/structural?preload\\_name=MTSOLAR\\_6C6AHG4B7G29&preload\\_path=Shared%20Enterprise%20Folder/MT\\_Solar\\_Projects/4\\_2023](https://platform.skyciv.com/structural?preload_name=MTSOLAR_6C6AHG4B7G29&preload_path=Shared%20Enterprise%20Folder/MT_Solar_Projects/4_2023)

Public Model Link:

[https://platform.skyciv.com/structural-viewer?project\\_id=wj2HKM5uUPgB1SzF34sbPEEM6X1KlefVbi1K6TLYbNsUmVqLpawcLdLrPBjs30v6](https://platform.skyciv.com/structural-viewer?project_id=wj2HKM5uUPgB1SzF34sbPEEM6X1KlefVbi1K6TLYbNsUmVqLpawcLdLrPBjs30v6)

## Array Specification

<b>Product:</b>	Beam
<b>Unique ID:</b>	1P-0-8TOP-HD-57-L-4Hx3W-CG4I
<b>Duty Classification:</b>	HD
<b>Module Width:</b>	40.00 in
<b>Module Length:</b>	67.75in
<b>Number of Rows:</b>	4
<b>Number of Columns:</b>	3
<b>Total Number of Modules:</b>	12
<b>Desired Tilt Angle:</b>	45
<b>Front Edge Clearance:</b>	5
<b>Total Array Height at Tilt:</b>	14.49 ft
<b>Total Frame Length:</b>	17.00 ft
<b>Frame Weight:</b>	979 lbs
<b>Array Dimensions N/S:</b>	13.50 ft
<b>Array Dimensions E/W:</b>	17.19 ft
<b>Rail Length:</b>	162.00 in
<b>Rail Spacing:</b>	2.82 ft
<b>Rail Check:</b>	Not Checked

## Support Specifications

<b>Pole Size:</b>	8in Pipe Sch 80
<b>Pole Length above Grade:</b>	9.77 ft
<b>Number of Poles:</b>	1
<b>Pole Spacing:</b>	0

## Foundation Specifications

<b>Foundation Type:</b>	Square
<b>Foundation Dimensions:</b>	48 x 48 in
<b>Foundation Depth (below grade):</b>	Pile 1: 7.25 ft
<b>Foundation Volume:</b>	4.296 y <sup>3</sup>
<b>Foundation Result:</b>	PASSED

## Site Info

<b>Risk Category:</b>	I
<b>Exposure:</b>	D
<b>Soil Classification:</b>	sand
<b>Site Location:</b>	E8549 Swamp Rd, Clintonville, WI 54929, USA
<b>Wind Speed:</b>	100 mph
<b>Snow Load:</b>	50 psf
<b>Design Uplift Pressure:</b>	Multiple pressures
<b>Design Downforce Pressure:</b>	Multiple pressures
<b>Design Snow Pressure:</b>	0.008640 ksf



### Design Disclaimer

This software should be used for preliminary designs and should not be used as a final design unless reviewed, verified and designed by a qualified structural engineer.

### AutoDesigner Input

```
{ "wind_speed_override": null, "snow_load_override": null, "direct_snow_load": false, "product_type": "Beam", "project_id": "MTSOLAR_6C6AHG4B7G29", "site_address": "E8549 Swamp Rd, Clintonville, WI 54929, USA", "module_width": 40, "module_length": 67.75, "number_rows": 4, "number_columns": 3, "pole_mount_section": "4_40", "core_pipe_width": 65, "core_pipe_section": "2_40", "adjuster_section": "2_40", "core_beam_height": 65, "core_beam_section": "HSS3x2x1/8", "main_pipe_section": "2_12GA", "pole_spacing": 15, "tilt_angle": 45, "ground_clearance": 5, "risk_category": "I", "exposure_category": "D", "frame_duty_override": "auto", "pole_override": "auto", "soil_type": "sand", "foundation_type": "Square", "foundation_size": 48, "check_rails": false }
```

### Design Notes:

- AISC Deflection checks are set to L/1 due to structure design intent
- Foundation Design and Sizing is approximate only

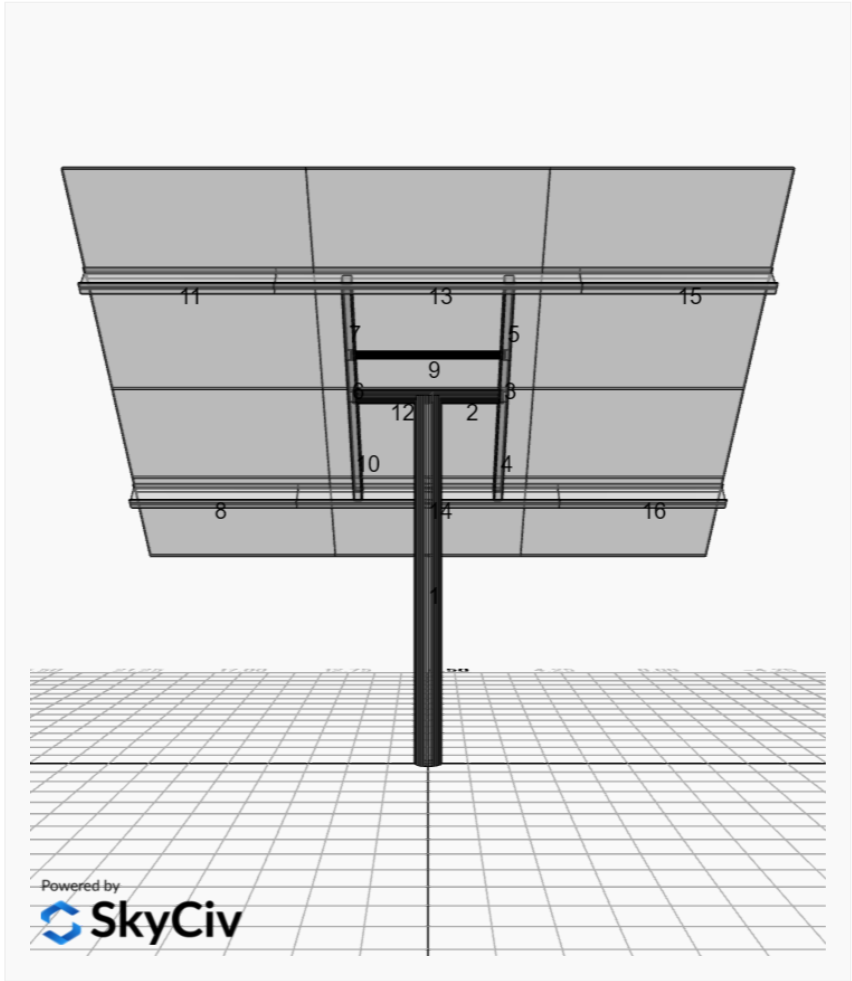

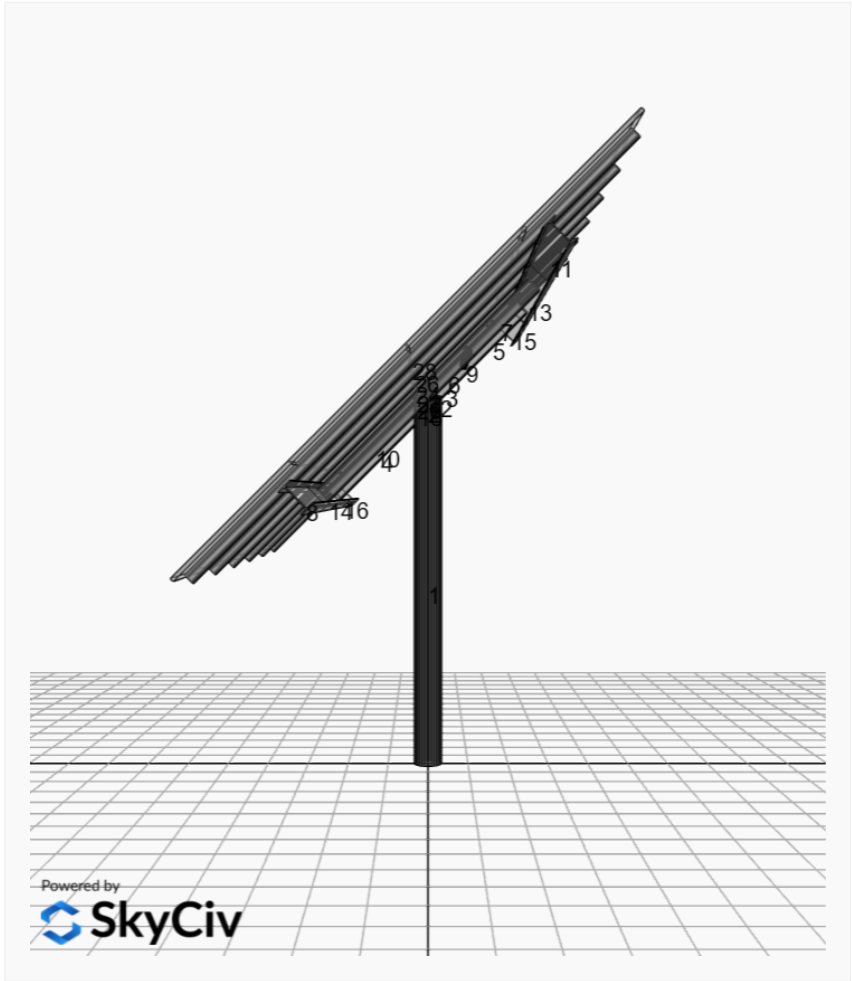

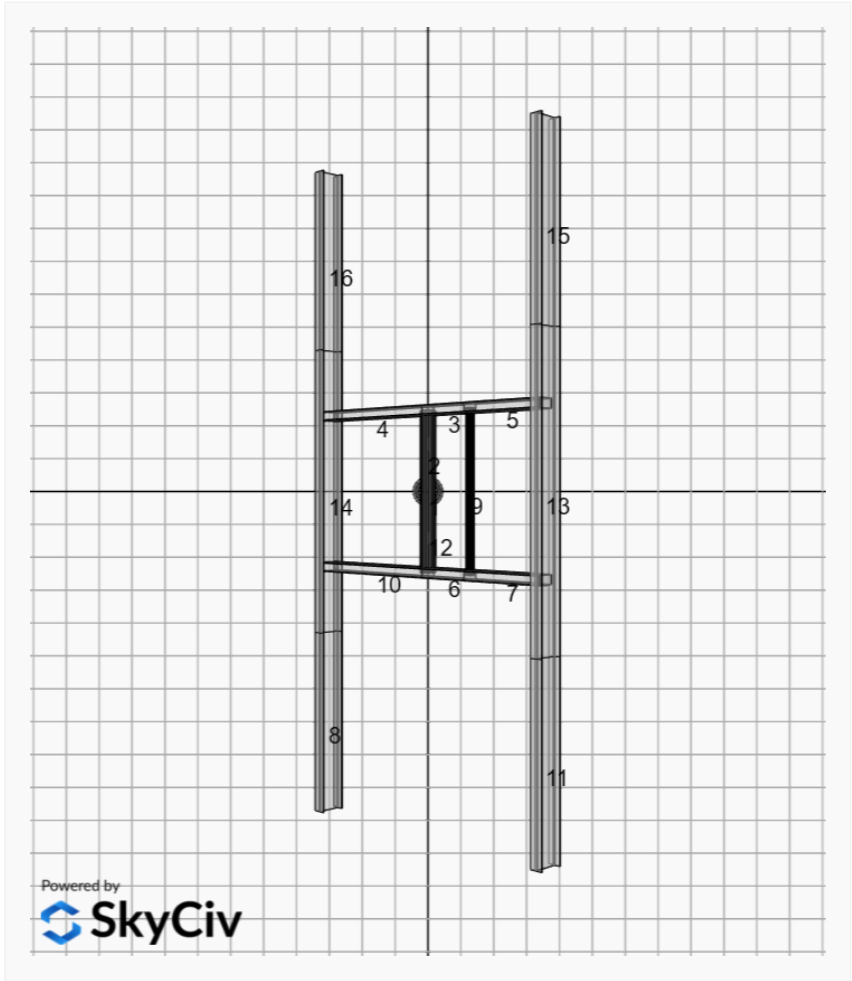



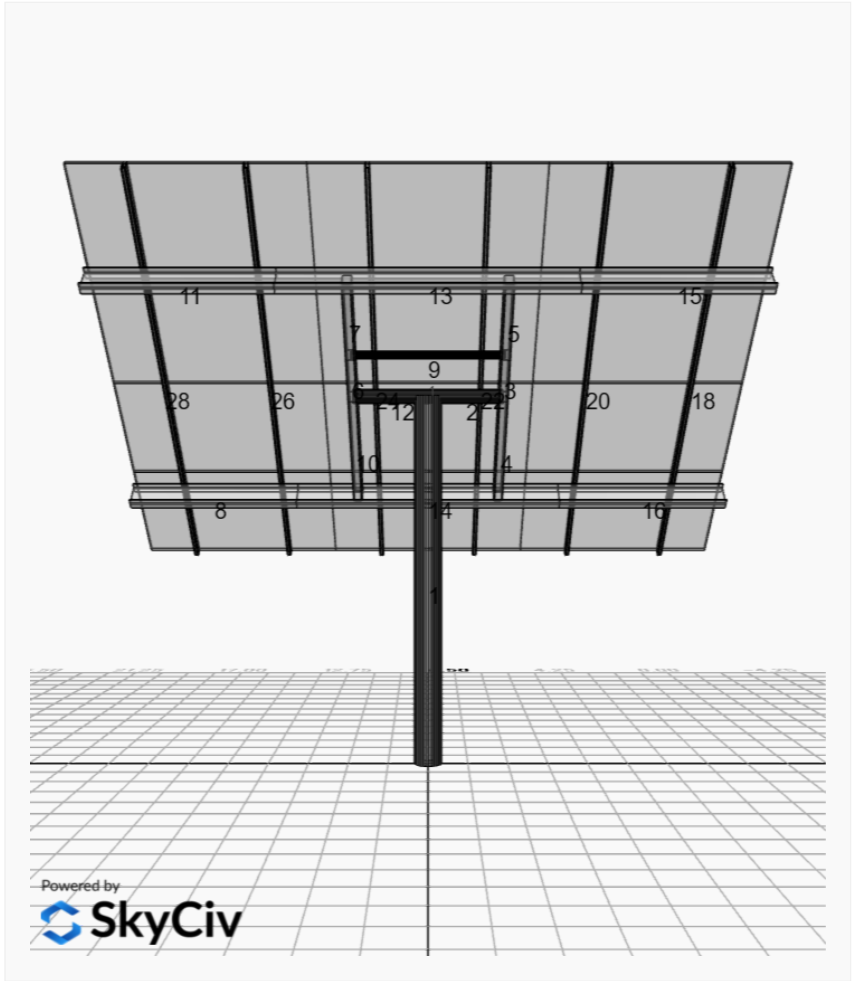

## FEM Results (Envelope Worst Case for each member)

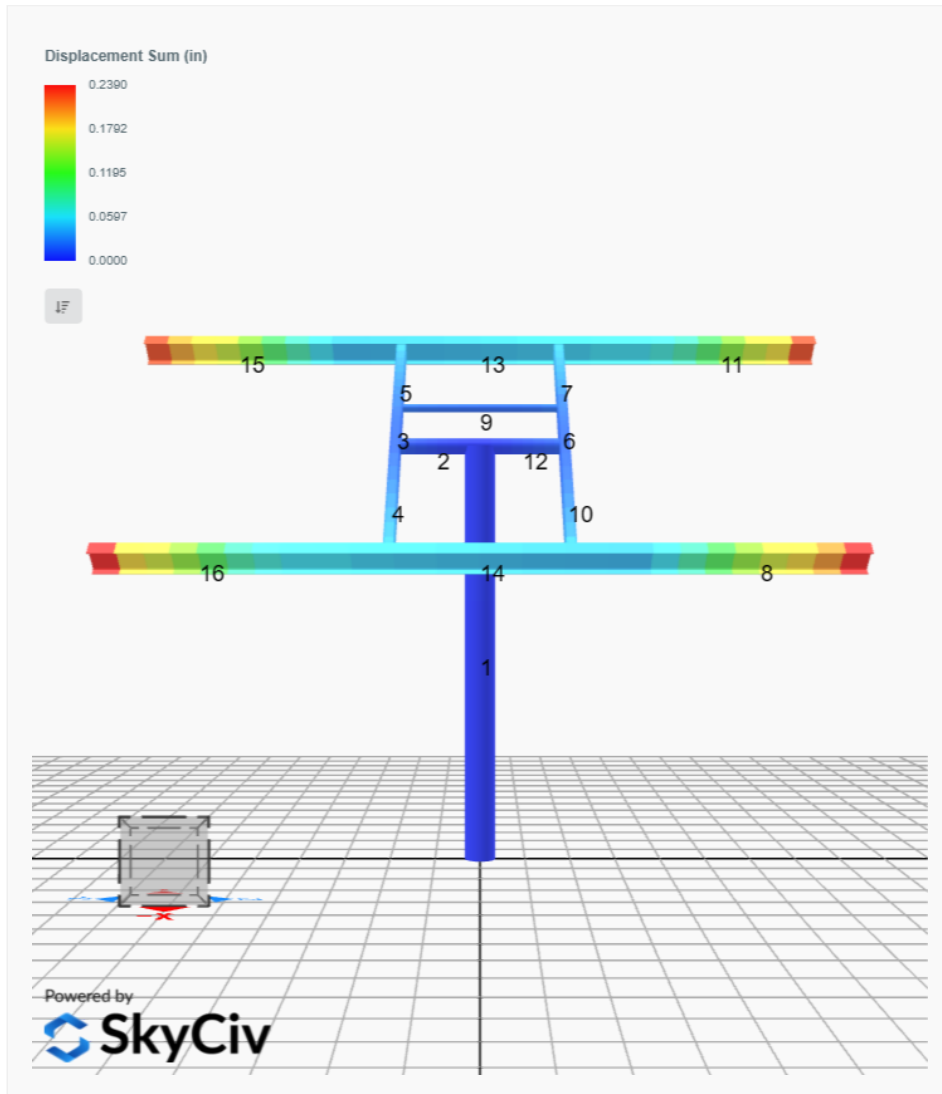

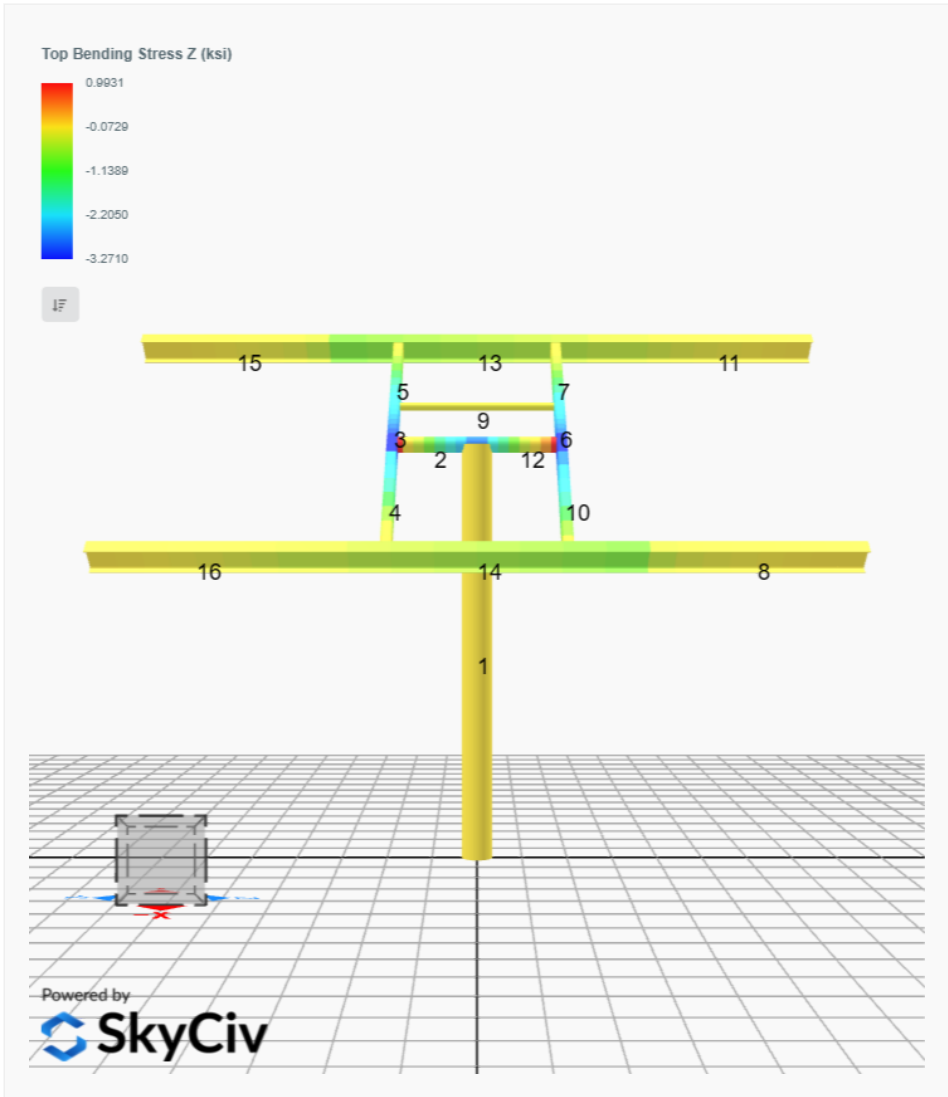

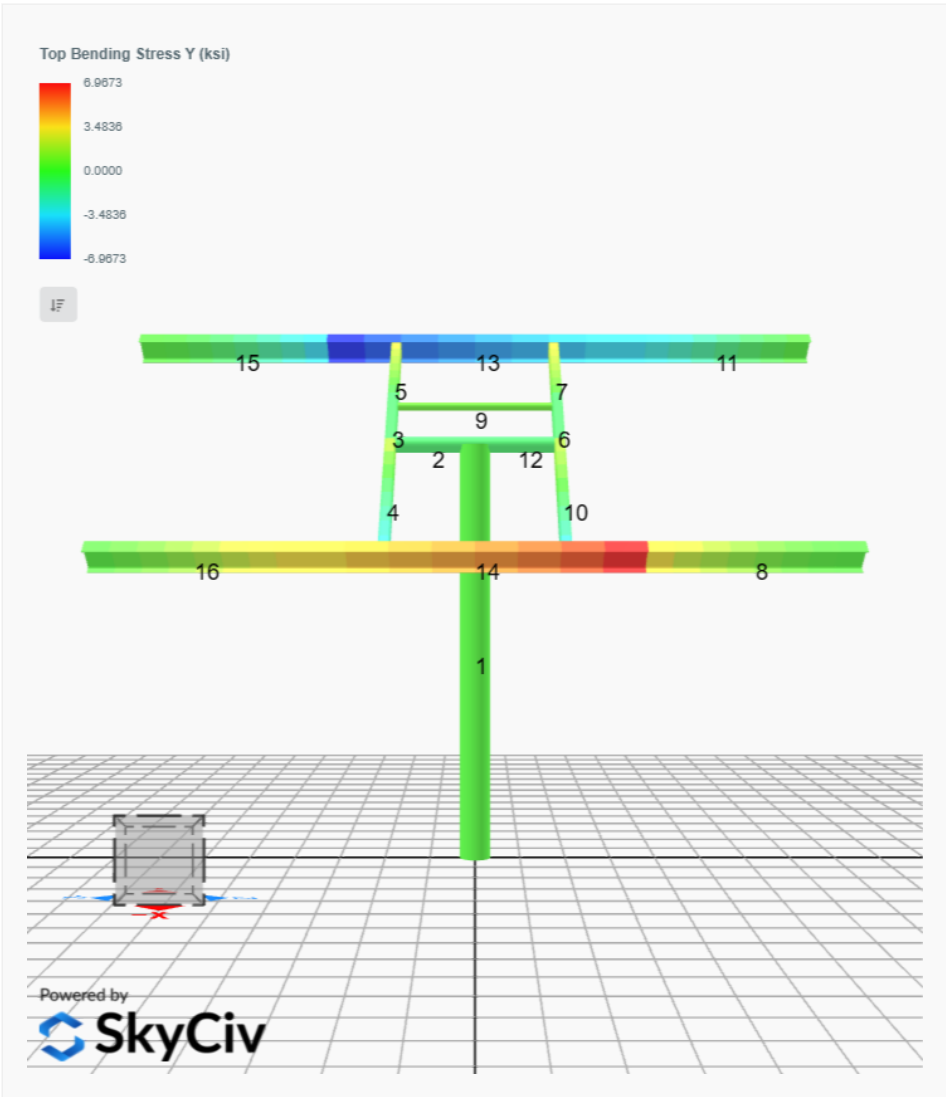

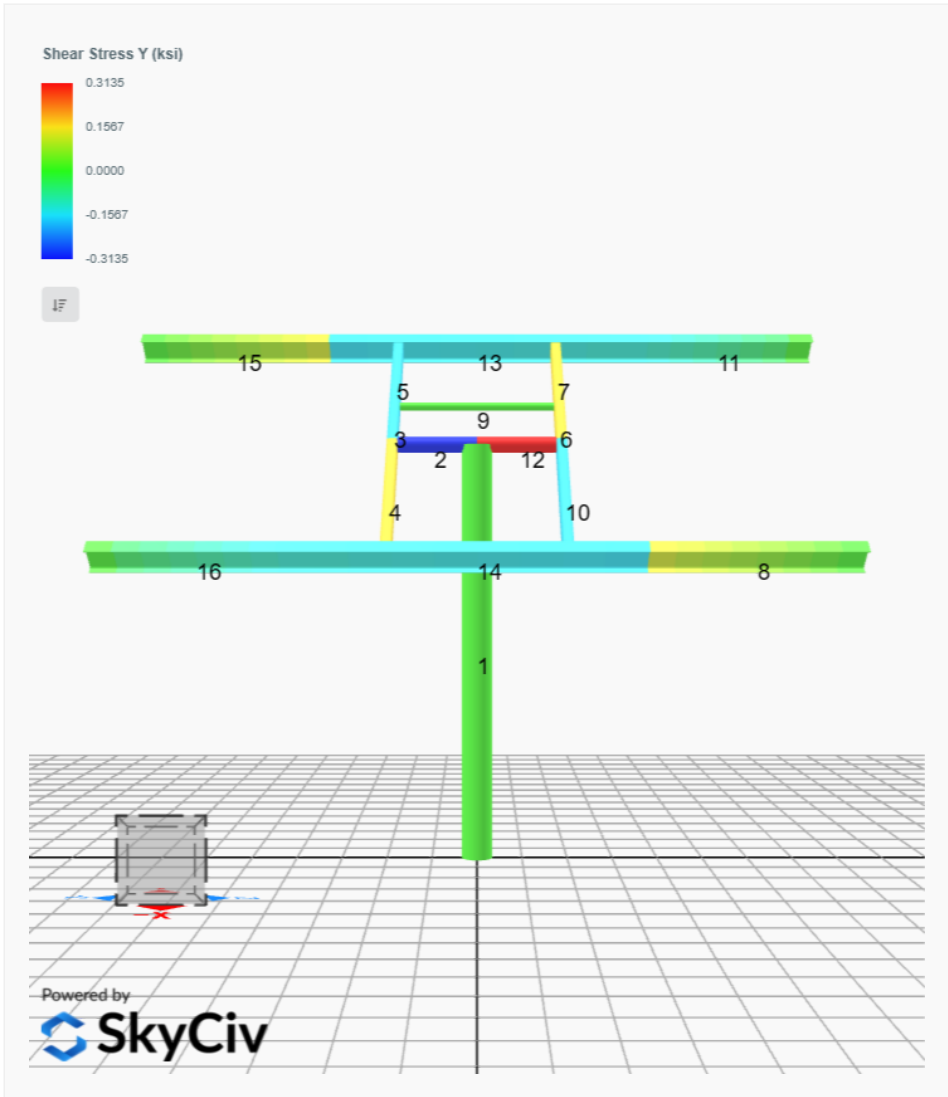

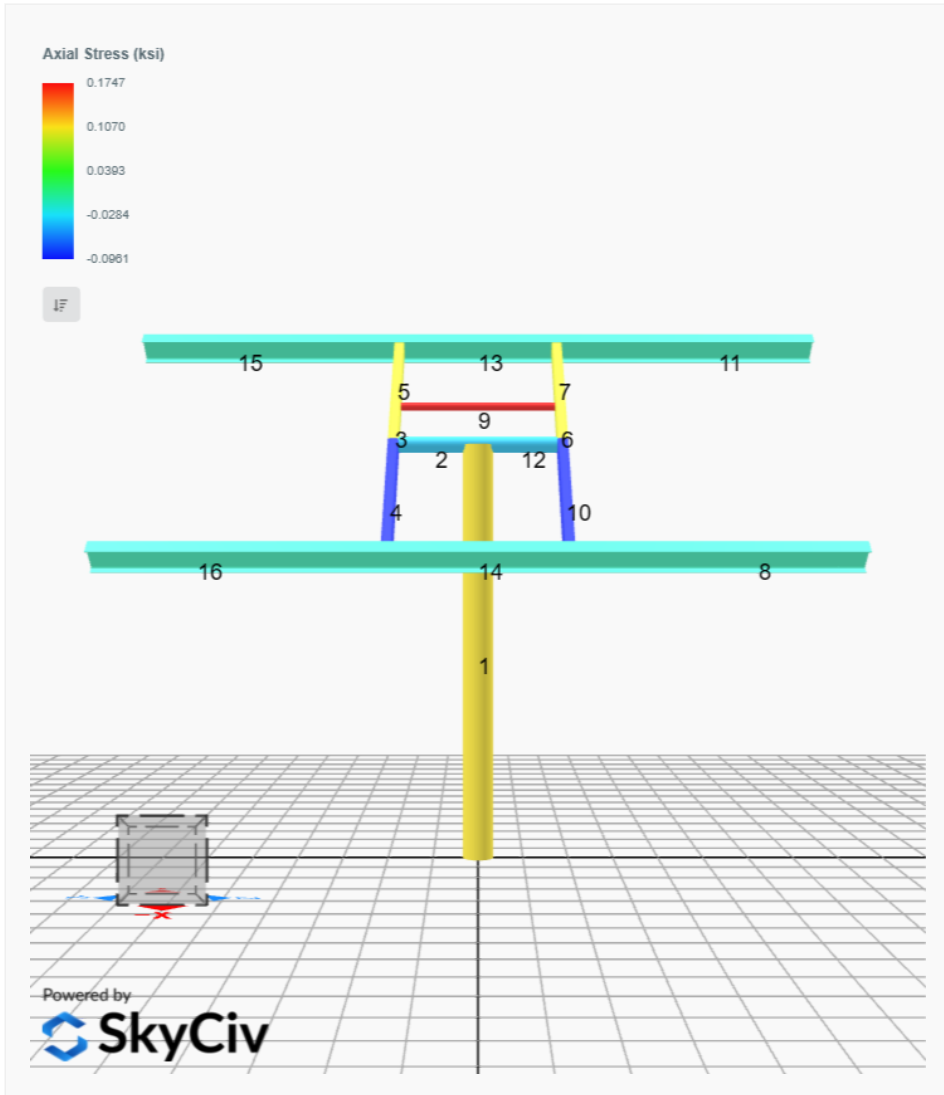

## Reaction Forces for Foundation 1 (Node ID#1), (kip, kip-ft)

### ASD Load Combination Results

Name	Fx	Fy	Fz	Mx	My	Mz
ULS: 1. D	0.0000	2.0868	0.0000	0.0000	-0.0000	0.0220
ULS: 2. D + L	0.0000	2.0868	0.0000	0.0000	-0.0000	0.0220
ULS: 3. D + (S or Lr or R)	0.0000	3.4888	-0.0000	0.0000	-0.0000	0.0245
ULS: 3. D + (S or Lr or R)	0.0000	2.0868	0.0000	0.0000	-0.0000	0.0220
ULS: 4. D + 0.75L + 0.75(S or Lr or R)	0.0000	3.1383	-0.0000	0.0000	-0.0000	0.0239
ULS: 4. D + 0.75L + 0.75(S or Lr or R)	0.0000	2.0868	0.0000	0.0000	-0.0000	0.0220
ULS: 5b. D + 0.7E	0.0000	2.0868	0.0000	0.0000	-0.0000	0.0220
ULS: 6b. D + 0.75L + 0.75(0.7)E + 0.75S	0.0000	3.1383	-0.0000	0.0000	-0.0000	0.0239
ULS: 8. 0.6D + 0.7E	0.0000	1.2521	0.0000	0.0000	-0.0000	0.0132
ULS: 5a. D + 0.6W_Wind downforce Case A only	-4.2719	6.3586	0.0000	0.0000	-0.0000	43.6904
ULS: 5a. D + 0.6W_Wind downforce Case B only	-4.2719	6.3586	0.0000	0.0000	-0.0000	43.6904
ULS: 5a. D + 0.6W_Wind uplift Case A only	3.0903	-1.0035	0.0000	0.0000	-0.0000	-28.9958
ULS: 5a. D + 0.6W_Wind uplift Case B only	2.7267	-0.6399	0.0000	0.0000	-0.0000	-34.0809
ULS: 6a. D + 0.75L + 0.75(0.6)W + 0.75(S or Lr or R)_Wind downforce Case A only	-3.2039	6.3422	0.0000	0.0000	-0.0000	32.7752
ULS: 6a. D + 0.75L + 0.75(0.6)W + 0.75(S or Lr or R)_Wind downforce Case B only	-3.2039	6.3422	0.0000	0.0000	-0.0000	32.7752
ULS: 6a. D + 0.75L + 0.75(0.6)W + 0.75(S or Lr or R)_Wind uplift Case A only	2.3177	0.8206	0.0000	0.0000	-0.0000	-21.7394
ULS: 6a. D + 0.75L + 0.75(0.6)W + 0.75(S or Lr or R)_Wind uplift Case B only	2.0450	1.0933	-0.0000	0.0000	-0.0000	-25.5533
ULS: 6a. D + 0.75L + 0.75(0.6)W + 0.75(S or Lr or R)_Wind downforce Case A only	-3.2039	5.2907	0.0000	0.0000	-0.0000	32.7733
ULS: 6a. D + 0.75L + 0.75(0.6)W + 0.75(S or Lr or R)_Wind downforce Case B only	-3.2039	5.2907	0.0000	0.0000	-0.0000	32.7733
ULS: 6a. D + 0.75L + 0.75(0.6)W + 0.75(S or Lr or R)_Wind uplift Case A only	2.3177	-0.2309	0.0000	0.0000	-0.0000	-21.7413
ULS: 6a. D + 0.75L + 0.75(0.6)W + 0.75(S or Lr or R)_Wind uplift Case B only	2.0450	0.0418	0.0000	0.0000	-0.0000	-25.5552
ULS: 7. 0.6D + 0.6W_Wind downforce Case A only	-4.2719	5.5239	0.0000	0.0000	-0.0000	43.6816
ULS: 7. 0.6D + 0.6W_Wind downforce Case B only	-4.2719	5.5239	0.0000	0.0000	-0.0000	43.6816
ULS: 7. 0.6D + 0.6W_Wind uplift Case A only	3.0903	-1.8382	0.0000	0.0000	-0.0000	-29.0045
ULS: 7. 0.6D + 0.6W_Wind uplift Case B only	2.7267	-1.4746	0.0000	0.0000	-0.0000	-34.0897

### Worst Case Reactions LRFD

These calculations are taken directly from the FEA via SkyCiv and are used in the Concrete Checks of the Foundation Module.  
Note: Worst case values are assumed as downforce wind load cases.

Result	Value
Axial	10.3249
Shear X	-7.1198
Shear Z	0.0000
Moment X	-0.0000
Moment Z	73.2234

### Worst Case Reactions ASD

These results are taken from the worst case values in the above table and are used in the Soil Checks in the Foundation Module.  
Note: Worst case values are assumed as downforce wind load cases.

Result	Value
Axial	6.3586
Shear X	-4.2719
Shear Z	0.0000
Moment X	0.0000
Moment Z	43.6904

## Project Details

Design Code: AISC 360-16 LRFD  
 Provision: LRFD  
 Country: United States

User Name: sales@mtsolar.us  
 Unit System: imperial



## Design Input Information

Design Factors			
$\Phi_t$	$\Phi_c$	$\Phi_b$	$\Phi_v$
0.9	0.9	0.9	0.9

Design Materials			
ID	E (ksi)	$F_y$ (ksi)	$F_u$ (ksi)
1	29000	50	65

### Section Dimensions

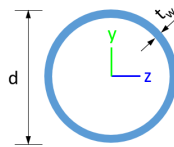

ID	Name	d (in)	$t_w$ (in)				
2	2in Pipe Sch 80	2.38	0.22				
5	4in Pipe Sch 80	4.50	0.34				
10	8in Pipe Sch 80	8.63	0.50				

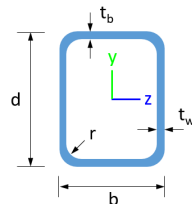

ID	Name	d (in)	b (in)	$t_w$ (in)	$t_b$ (in)	r (in)	
16	HSS5x3x3/16	5.00	3.00	0.17	0.17	0.17	

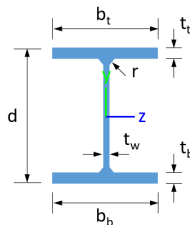

ID	Name	d (in)	$t_w$ (in)	$b_t$ (in)	$b_b$ (in)	$t_t$ (in)	$t_b$ (in)	r (in)
19	W8x10	7.89	0.17	3.94	3.94	0.20	0.20	0.30

### Section Properties

ID	Name	A (in <sup>2</sup> )	J (in <sup>4</sup> )	$I_{yp}$ (in <sup>4</sup> )	$I_{zp}$ (in <sup>4</sup> )	$I_w$ (in <sup>6</sup> )	$S_{yp}$ (in <sup>3</sup> )	$S_{zp}$ (in <sup>3</sup> )
2	2in Pipe Sch 80	1.48	1.74	0.87	0.87	0.00	1.02	1.02
5	4in Pipe Sch 80	4.41	19.22	9.61	9.61	0.00	5.85	5.85
10	8in Pipe Sch 80	12.76	211.43	105.72	105.72	0.00	33.05	33.05



2	198.33	196.72	21.95	21.95	59.50	59.50
3	116.10	115.41	15.79	11.10	42.08	23.28
4	116.10	111.33	15.79	11.10	42.08	23.28
5	116.10	114.23	15.79	11.10	42.08	23.28
6	116.10	115.41	15.79	11.10	42.08	23.28
7	116.10	114.23	15.79	11.10	42.08	23.28
8	133.20	32.95	32.87	6.12	40.24	43.62
9	66.48	58.89	3.82	3.82	19.94	19.94
10	116.10	111.33	15.79	11.10	42.08	23.28
11	133.20	32.95	32.87	6.12	40.24	43.62
12	198.33	196.72	21.95	21.95	59.50	59.50
13	133.20	126.79	32.87	6.12	40.24	43.62
14	133.20	126.79	32.87	6.12	40.24	43.62
15	133.20	32.95	32.87	6.12	40.24	43.62
16	133.20	32.95	32.87	6.12	40.24	43.62
17	133.20	118.19	32.76	6.12	40.24	43.62
18	133.20	126.79	32.87	6.12	40.24	43.62
19	133.20	118.19	32.14	6.12	40.24	43.62
20	133.20	126.79	32.87	6.12	40.24	43.62

## Design Ratio

Member ID	P	M <sub>z</sub>	M <sub>y</sub>	V <sub>y</sub>	V <sub>z</sub>	(P,M <sub>z</sub> ,M <sub>y</sub> )	Worst LC	KL/r	δ	Status
1	0.031	0.591	0.000	0.041	0.000	0.606	#13	0.428	Not Required	Pass
2	0.003	0.384	0.311	0.082	0.060	0.696	#13	0.035	Not Required	Pass
3	0.006	0.746	0.033	0.075	0.002	0.769	#13	0.045	Not Required	Pass
4	0.006	0.667	0.120	0.067	0.025	0.716	#13	0.080	Not Required	Pass
5	0.006	0.463	0.124	0.074	0.032	0.483	#13	0.074	Not Required	Pass
6	0.006	0.746	0.033	0.075	0.002	0.769	#13	0.045	Not Required	Pass
7	0.006	0.463	0.124	0.074	0.032	0.483	#13	0.074	Not Required	Pass
8	0.000	0.113	0.153	0.039	0.009	0.229	#21	Not Required	Not Required	Pass
9	0.012	0.057	0.062	0.001	0.000	0.122	#13	0.204	Not Required	Pass
10	0.006	0.667	0.120	0.067	0.025	0.716	#13	0.080	Not Required	Pass
11	0.000	0.126	0.153	0.043	0.009	0.235	#21	Not Required	Not Required	Pass
12	0.003	0.384	0.311	0.082	0.060	0.696	#13	0.035	Not Required	Pass
13	0.000	0.235	0.286	0.059	0.012	0.441	#21	Not Required	Not Required	Pass
14	0.000	0.211	0.286	0.053	0.012	0.428	#21	Not Required	Not Required	Pass
15	0.000	0.126	0.153	0.043	0.009	0.235	#21	Not Required	Not Required	Pass
16	0.000	0.113	0.153	0.039	0.009	0.229	#21	Not Required	Not Required	Pass
17	0.006	0.246	0.061	0.018	0.004	0.284	#13	0.124	Not Required	Pass
18	0.000	0.235	0.286	0.059	0.012	0.441	#21	Not Required	Not Required	Pass
19	0.005	0.227	0.069	0.016	0.004	0.270	#13	0.186	Not Required	Pass
20	0.000	0.211	0.286	0.053	0.012	0.428	#21	Not Required	Not Required	Pass

## Definitions

$\Phi_t$	Safety factor for tensile
$\Phi_c$	Safety factor for compression
$\Phi_b$	Safety factor for flexure
$\Phi_v$	Safety factor for shear
E	Modulus of elasticity
F <sub>y</sub>	Specified minimum yield stress
F <sub>u</sub>	Specified minimum tensile strength
A	Cross-sectional area
J	Torsional constant
I <sub>y</sub>	Moment of inertia about the Y axis

$I_{yp}$	Moment of inertia about the Y axes
$I_{zp}$	Moment of inertia about the Z axes
$I_w$	Warping constant
$S_{yp}$	Plastic section modulus about the Y axis
$S_{zp}$	Plastic section modulus about the Z axis
KL	Effective length
$C_b$	Buckling modification factor (from all load combinations)
$L_b$	Length between braced points
LST	Limited slenderness for tension
LSC	Limited slenderness for compression
LD	Limited deflection
$P_n$	Nominal axial strength (tension/compression)
$M_n$	Nominal flexural strength (about Z/Y axis)
$V_n$	Nominal shear strength (along Z/Y axis)
P	Design ratio in case of axial force
$M_z$	Design ratio in case of bending about Z axis
$M_y$	Design ratio in case of bending about Y axis
$V_y$	Design ratio in case of shear along Y axis
$V_z$	Design ratio in case of shear along Z axis
$(P, M_z, M_y)$	Design ratio in case of axial force and bending action
KL/r	Design ratio in case of section slenderness
$\delta$	Design ratio in case of member deflection
OK	Capacity is provided
NG	Capacity is not provided

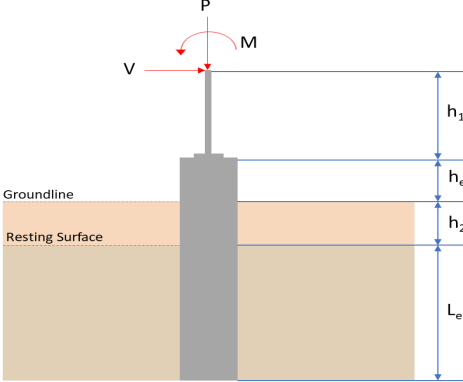
REFERENCES	CALCULATIONS	RESULTS																										
	<p><b>SkyCiv Foundation Design</b> Pile Foundation</p> <p><b>Design Information :</b> Design code : IBC 2021 (International Building Code) Unit System : Imperial</p>																											
	<p><b>Pile Input</b></p>  <p><b>Geometry</b> Pile shape: rectangular <math>b = 48</math> in - Pile width <math>D = 48</math> in - Pile depth <math>L = 7.25</math> ft - Total pile length <math>h_1 = 0</math> ft - Lateral load height from the top of the pile, <math>h_2 = 0</math> ft - Depth to resting surface <math>h_e = 0</math> ft - Length of pile above the ground</p> <p><b>Tabulation of Soil Parameters</b></p> <table border="1" data-bbox="416 1102 1193 1191"> <thead> <tr> <th>Layer</th> <th>Label</th> <th>Allowable Bearing Pressure (<math>q_a</math>) (psf)</th> <th>Allowable Lateral Pressure (<math>R</math>) (psf/ft)</th> </tr> </thead> <tbody> <tr> <td>1</td> <td>Sand, silty sand, clayey sand, silty gravel &amp; clayey gravel</td> <td>2000.000</td> <td>150.000</td> </tr> </tbody> </table> <p><b>Tabulation of Loads</b></p> <table border="1" data-bbox="676 1285 933 1458"> <thead> <tr> <th>Load Component</th> <th>ASD</th> <th>LRFD</th> </tr> </thead> <tbody> <tr> <td><math>P</math> (kip)</td> <td>6.359</td> <td>10.325</td> </tr> <tr> <td><math>V_x</math> (kip)</td> <td>-4.272</td> <td>-7.120</td> </tr> <tr> <td><math>V_z</math> (kip)</td> <td>0.000</td> <td>0.000</td> </tr> <tr> <td><math>M_x</math> (kipft)</td> <td>0.000</td> <td>0.000</td> </tr> <tr> <td><math>M_z</math> (kipft)</td> <td>43.690</td> <td>73.223</td> </tr> </tbody> </table> <p><b>Material Properties</b> <math>f'_{ck} = 3</math> ksi - Concrete strength,</p>	Layer	Label	Allowable Bearing Pressure ( $q_a$ ) (psf)	Allowable Lateral Pressure ( $R$ ) (psf/ft)	1	Sand, silty sand, clayey sand, silty gravel & clayey gravel	2000.000	150.000	Load Component	ASD	LRFD	$P$ (kip)	6.359	10.325	$V_x$ (kip)	-4.272	-7.120	$V_z$ (kip)	0.000	0.000	$M_x$ (kipft)	0.000	0.000	$M_z$ (kipft)	43.690	73.223	
Layer	Label	Allowable Bearing Pressure ( $q_a$ ) (psf)	Allowable Lateral Pressure ( $R$ ) (psf/ft)																									
1	Sand, silty sand, clayey sand, silty gravel & clayey gravel	2000.000	150.000																									
Load Component	ASD	LRFD																										
$P$ (kip)	6.359	10.325																										
$V_x$ (kip)	-4.272	-7.120																										
$V_z$ (kip)	0.000	0.000																										
$M_x$ (kipft)	0.000	0.000																										
$M_z$ (kipft)	43.690	73.223																										
	<p><b>Required depth to resist lateral loads (ASD)</b> <math>H</math> - Point of application of the lateral load</p> $H = h_1 + h_2 + h_e$ $H = (0 \text{ ft}) + (0 \text{ ft}) + (0 \text{ ft})$ $H = 0 \text{ ft}$ <p><b>Considering x-direction:</b> <math>H_o</math> - Lateral force per length of pile,</p> $H_o = \frac{V_x}{1.57 D}$ $H_o = \frac{(-4.272 \text{ kip})}{1.57 \times (48 \text{ in})}$ $H_o = -0.68025 \text{ kip/ft}$ <p><math>M_o</math> - Moment per length of pile,</p> $M_o = \frac{M_z + (V_x H)}{1.57 D}$																											

	$M_o = \frac{(43.69 \text{ kipft}) + ((-4.272 \text{ kip}) \times (0 \text{ ft}))}{1.57 \times (48 \text{ in})}$ $M_o = 6.957 \text{ kipft/ft}$ <p>Required depth of embedment in earth:</p> $L_x^3 - \left(14.14 \times \frac{H_o \times L_x}{R}\right) - \left(18.85 \times \frac{M_o}{R}\right) = 0$ <p>Solving the cubic equation:  <math>L_{e,x} = 6.5982 \text{ ft}</math> - Required depth in x-direction,</p> <p><b>Considering z-direction:</b>  <math>L_{e,z} = 0 \text{ ft}</math> - Required depth in z-direction,</p> <p><b>Minimum embedded depth required:</b>  <math>L_{e,req}</math> - Depth of pile required,</p> $L_{e,req} = \text{MAX}[L_{e,x}, L_{e,z}]$ $L_{e,req} = \text{MAX}[(6.5982 \text{ ft}), (0 \text{ ft})]$ $L_{e,req} = 6.598 \text{ ft}$ <p><math>L_e</math> - Actual embedded length of pile,</p> $L_e = L - h_e - h_2$ $L_e = (7.25 \text{ ft}) - (0 \text{ ft}) - (0 \text{ ft})$ $L_e = 7.25 \text{ ft}$ <p><i>Ratio</i> - Embedded depth</p> $\text{Ratio} = \frac{L_{e,req}}{L_e}$ $\text{Ratio} = \frac{(6.598 \text{ ft})}{(7.25 \text{ ft})}$ $\text{Ratio} = 0.91007$	<p>Status: <b>PASS</b>  Ratio: <b>0.910</b></p>
	<p><b>End-bearing Capacity (ASD)</b></p> <p>A - Pile cross-section area</p> $A = b D$ $A = (48 \text{ in}) \times (48 \text{ in})$ $A = 16 \text{ ft}^2$ <p>q - End-bearing pressure</p> $q = \frac{P_u}{A}$ $q = \frac{(6.359 \text{ kip})}{(16 \text{ ft}^2)}$ $q = 0.39744 \text{ kip/ft}^2$ <p><b>Check bearing capacity ratio:</b></p> <p><i>Ratio</i> - Capacity</p> $\text{Ratio} = \frac{q}{q_o}$ $\text{Ratio} = \frac{(0.39744 \text{ kip/ft}^2)}{(2000 \text{ psf})}$ $\text{Ratio} = 0.19872$	<p>Status: <b>PASS</b>  Ratio: <b>0.200</b></p>
<p>Czerniak</p>	<p><b>Lateral Soil Pressure (ASD):</b></p> <p><math>L/D</math> - Length to least lateral dimension ratio,</p> $L/D = \frac{L}{D}$ $L/D = \frac{(7.25 \text{ ft})}{(48 \text{ in})}$	

$$L/D = 1.8125$$

Since  $L/D \leq 10$ ,

Pile is short.

**Considering x-direction:**

$H_o = -0.68025$  kip/ft - Lateral force per length of pile,

$M_o = 6.957$  kipft/ft - Overturning moment per length of pile,

$a$  - Distance from resting surface to pivot point,

$$a = \frac{(4 M_o L_e) + (3 H_o L_e^2)}{(6 M_o) + (4 H_o L_e)}$$

$$a = \frac{(4 \times (6.957 \text{ kipft/ft}) \times (7.25 \text{ ft})) + (3 \times (-0.68025 \text{ kip/ft}) \times (7.25 \text{ ft})^2)}{(6 \times (6.957 \text{ kipft/ft})) + (4 \times (-0.68025 \text{ kip/ft}) \times (7.25 \text{ ft}))}$$

$$a = 5.0272 \text{ ft}$$

$p$  - Earth pressure against the pile at distance  $a/2$  from resting surface,

$$p = \frac{0.75 [(4 M_o) + (3 H_o L_e)]^2}{L_e^2 [(3 M_o) + (2 H_o L_e)]}$$

$$p = \frac{0.75 \times [(4 \times (6.957 \text{ kipft/ft})) + (3 \times (-0.68025 \text{ kip/ft}) \times (7.25 \text{ ft}))]^2}{(7.25 \text{ ft})^2 \times [(3 \times (6.957 \text{ kipft/ft})) + (2 \times (-0.68025 \text{ kip/ft}) \times (7.25 \text{ ft}))]}$$

$$p = 0.22017 \text{ kip/ft}^2$$

$s$  - Earth pressure against the pile at distance  $L_e$ ,

$$s = \frac{6 [(2 M_o) + (H_o L_e)]}{L_e^2}$$

$$s = \frac{6 \times [(2 \times (6.957 \text{ kipft/ft})) + ((-0.68025 \text{ kip/ft}) \times (7.25 \text{ ft}))]}{(7.25 \text{ ft})^2}$$

$$s = 1.0253 \text{ kip/ft}^2$$

**Check lateral soil pressure capacity:**

$p_a$  - Allowable lateral soil pressure at depth  $a/2$ ,

$$p_a = R \frac{q}{2}$$

$$p_a = (150 \text{ psf/ft}) \times \frac{(5.0272 \text{ ft})}{2}$$

$$p_a = 0.37704 \text{ kip/ft}^2$$

*Ratio* - Lateral soil capacity

$$\text{Ratio} = \frac{p}{p_a}$$

$$\text{Ratio} = \frac{(0.22017 \text{ kip/ft}^2)}{(0.37704 \text{ kip/ft}^2)}$$

$$\text{Ratio} = 0.58394$$

$p_s$  - Allowable lateral soil pressure at depth  $L_e$ ,

$$p_s = R L_e$$

$$p_s = (150 \text{ psf/ft}) \times (7.25 \text{ ft})$$

$$p_s = 1.0875 \text{ kip/ft}^2$$

*Ratio* - Lateral soil capacity

$$\text{Ratio} = \frac{s}{p_s}$$

$$\text{Ratio} = \frac{(1.0253 \text{ kip/ft}^2)}{(1.0875 \text{ kip/ft}^2)}$$

$$\text{Ratio} = 0.94282$$

Status: **PASS**  
Ratio: **0.580**

Status: **PASS**  
Ratio: **0.940**

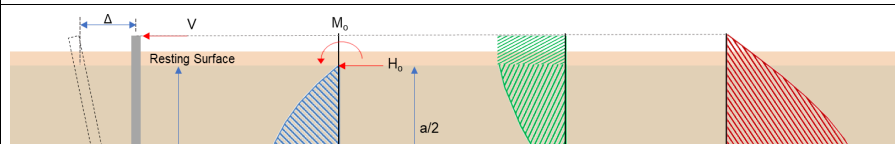

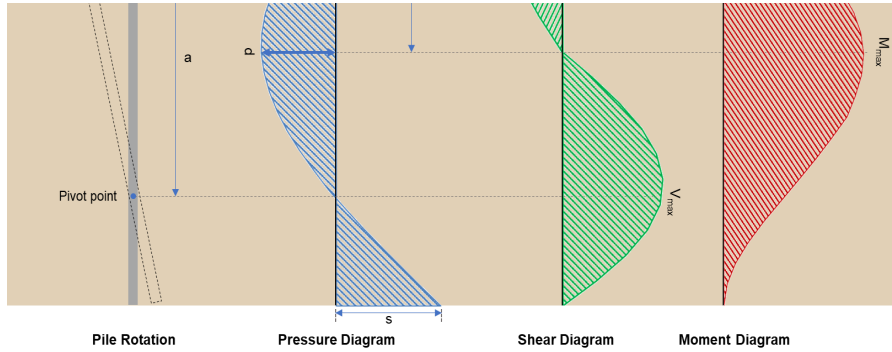

### Shear force and Bending moment (x-direction, LRFD)

$H_o$  - Lateral force per length of pile,

$$H_o = \frac{V_x}{1.57 D}$$

$$H_o = \frac{(-7.12 \text{ kip})}{1.57 \times (48 \text{ in})}$$

$$H_o = -1.1338 \text{ kip/ft}$$

$M_o$  - Moment per length of pile,

$$M_o = \frac{M_x + (V_x H)}{1.57 D}$$

$$M_o = \frac{(73.223 \text{ kipft}) + ((-7.12 \text{ kip}) \times (0 \text{ ft}))}{1.57 \times (48 \text{ in})}$$

$$M_o = 11.66 \text{ kipft/ft}$$

$E$  - Distance from lateral load to resisting surface,

$$E = \frac{M_o}{H_o}$$

$$E = \frac{(11.66 \text{ kipft/ft})}{(-1.1338 \text{ kip/ft})}$$

$$E = 10.284 \text{ ft}$$

$a$  - Distance from resting surface to pivot point,

$$a = \frac{(4 M_o L_c) + (3 H_o L_c^2)}{(6 M_o) + (4 H_o L_c)}$$

$$a = \frac{(4 \times (11.66 \text{ kipft/ft}) \times (7.25 \text{ ft})) + (3 \times (-1.1338 \text{ kip/ft}) \times (7.25 \text{ ft})^2)}{(6 \times (11.66 \text{ kipft/ft})) + (4 \times (-1.1338 \text{ kip/ft}) \times (7.25 \text{ ft}))}$$

$$a = 5.0265 \text{ ft}$$

$V_{max}$  - Max shear force located at depth  $a$ ,

$$V_{max} = (H_o D) \left[ 1 - \left[ 3 \left( \frac{4 E}{L_c} + 3 \right) \left( \frac{a}{L_c} \right)^2 \right] + \left[ 4 \left( \frac{3 E}{L_c} + 2 \right) \left( \frac{a}{L_c} \right)^3 \right] \right]$$

$$V_{max} = ((-1.1338 \text{ kip/ft}) \times (48 \text{ in})) \times \left[ 1 - \left[ 3 \times \left( \frac{4 \times (10.284 \text{ ft})}{(7.25 \text{ ft})} + 3 \right) \times \left( \frac{(5.0265 \text{ ft})}{(7.25 \text{ ft})} \right)^2 \right] + \left[ 4 \times \left( \frac{3 \times (10.284 \text{ ft})}{(7.25 \text{ ft})} + 2 \right) \times \left( \frac{(5.0265 \text{ ft})}{(7.25 \text{ ft})} \right)^3 \right] \right]$$

$$V_{max} = 14.373 \text{ kip}$$

$M_{max}$  - Max bending moment located at depth  $a/2$ ,

$$M_{max} = (H_o D L_c) \left[ \left( \frac{E}{L_c} + \frac{a}{2 L_c} \right) - \left[ \left( \frac{4 E}{L_c} + 3 \right) \left( \frac{a}{2 L_c} \right)^3 \right] + \left[ \left( \frac{3 E}{L_c} + 2 \right) \left( \frac{a}{2 L_c} \right)^4 \right] \right]$$

$$M_{max} = ((-1.1338 \text{ kip/ft}) \times (48 \text{ in}) \times (7.25 \text{ ft})) \times \left[ \left( \frac{(10.284 \text{ ft})}{(7.25 \text{ ft})} + \frac{(5.0265 \text{ ft})}{2 \times (7.25 \text{ ft})} \right) - \left[ \left( \frac{4 \times (10.284 \text{ ft})}{(7.25 \text{ ft})} + 3 \right) \times \left( \frac{(5.0265 \text{ ft})}{2 \times (7.25 \text{ ft})} \right)^3 \right] + \left[ \left( \frac{3 \times (10.284 \text{ ft})}{(7.25 \text{ ft})} + 2 \right) \times \left( \frac{(5.0265 \text{ ft})}{2 \times (7.25 \text{ ft})} \right)^4 \right] \right]$$

$$M_{max} = 49.126 \text{ kipft}$$

### Minimum Reinforcement Check (LRFD)

#### Parameters:

$f'_{ck} = 3 \text{ ksi}$  - Concrete strength,  
 $f_{yk} = 60 \text{ ksi}$  - Longitudinal reinforcement strength,  
 $\phi = 0.65$  - Reduction factor for axial strength,  
 $\alpha = 0.8$  - Alpha factor for axial strength,  
 $A_g = 2304 \text{ in}^2$  - Gross area of concrete,

Table 22.4.2.1

#### Longitudinal reinforcement:

Required reinforcement due to axial load,  $A_{st,required}$

22.4.2.2, 10.6.1.1

$A_{st,required}$

$$A_{st,required} = \text{Min} \left[ \frac{\frac{P}{\phi \alpha} - (0.85 f'_{ck} A_g)}{f_{yk} - (0.85 f'_{ck})}, (0.08 A_g) \right]$$

$$A_{st,required} = \text{Min} \left[ \frac{\frac{(10.325 \text{ kip})}{(0.65) \times (0.8)} - (0.85 \times (3 \text{ ksi}) \times (2304 \text{ in}^2))}{(60 \text{ ksi}) - (0.85 \times (3 \text{ ksi}))}, (0.08 \times (2304 \text{ in}^2)) \right]$$

$$A_{st,required} = -101.92 \text{ in}^2$$

$A_{min}$  - Governing minimum reinforcement area,

$$A_{min} = \text{Max} [A_{st,required}, (0.0018 A_g)]$$

$$A_{min} = \text{Max} [(-101.92 \text{ in}^2), (0.0018 \times (2304 \text{ in}^2))]$$

$$A_{min} = 4.1472 \text{ in}^2$$

$n_{rebar}$  - Required number of reinforcement,

$$n_{rebar} = \frac{A_{min}}{A_{rebar}}$$

$$n_{rebar} = \frac{(4.1472 \text{ in}^2)}{(0.3068 \text{ in}^2)}$$

$$n_{rebar} = 14$$

$A_{st}$  - Actual total reinforcement area,

$$A_{st} = n_{rebar} \frac{\pi d_{bar}^2}{4}$$

$$A_{st} = (14) \times \frac{\pi \times (0.625 \text{ in})^2}{4}$$

$$A_{st} = 4.2951 \text{ in}^2$$

Ratio - Capacity

$$\text{Ratio} = \frac{A_{min}}{A_{st}}$$

$$\text{Ratio} = \frac{(4.1472 \text{ in}^2)}{(4.2951 \text{ in}^2)}$$

$$\text{Ratio} = 0.96556$$

Status: **PASS**  
Ratio: **0.970**

25.2.3

$s_{rebar}$  - Minimum spacing of reinforcement,

$$s_{rebar} = \text{Max} [1.5, (1.5 d_{bar})]$$

$$s_{rebar} = \text{Max} [1.5, (1.5 \times (0.625 \text{ in}))]$$

$$s_{rebar} = 1.5 \text{ in}$$

#### Ties:

25.7.2.2 Since longitudinal reinforcement is  $\leq$  No. 10: Use #3(0.375 in)

25.7.2.1

$s_{ties}$  - Maximum spacing of ties,

$$s_{ties} = \text{Min} [(16 d_{bar}), (48 d_{ties}), \text{Min} (D, b)]$$

$$s_{ties} = \text{Min} [(16 \times (0.625 \text{ in})), (48 \times (0.375 \text{ in})), \text{Min} ((48 \text{ in}), (48 \text{ in}))]$$

$$s_{ties} = 10 \text{ in}$$

#### Summary:

Main reinforcement: **14 - #5 (0.625 in)**

**Axial Compression Strength (ACI 318-19, LRFD)**22.4.2.2  $\phi P_N$  - Allowable axial compressive strength

$$\phi P_N = \phi 0.80 [(0.85 f'_{ck} [A_g - A_{st}]) + (f_{yk} A_{st})]$$

$$\phi P_N = (0.65) \times 0.80 \times [(0.85 \times (3 \text{ ksi}) \times [(2304 \text{ in}^2) - (4.2951 \text{ in}^2)]) + ((60 \text{ ksi}) \times (4.2951 \text{ in}^2))]$$

$$\phi P_N = 3183.4 \text{ kip}$$

Ratio - Capacity

$$\text{Ratio} = \frac{P}{\phi P_N}$$

$$\text{Ratio} = \frac{(10.325 \text{ kip})}{(3183.4 \text{ kip})}$$

$$\text{Ratio} = 0.0032434$$

Status: **PASS**  
Ratio: **0.000****Shear Strength (ACI 318-19, LRFD)****Parameters:** $b_w = 48 \text{ in}$  - Effective width,22.5.2.2  $d$  - Effective depth

$$d = 0.80 D$$

$$d = 0.80 \times (48 \text{ in})$$

$$d = 38.4 \text{ in}$$

22.5.5.1.3  $\lambda_s$  - size effect modification factor

$$\lambda_s = \text{MIN} \left[ \sqrt{\frac{2}{1 + \frac{d}{10}}}, 1 \right]$$

$$\lambda_s = \text{MIN} \left[ \sqrt{\frac{2}{1 + \frac{(38.4 \text{ in})}{10}}}, 1 \right]$$

$$\lambda_s = 0.64282$$

The following variables were converted to be consistent with empirical formula  $f'_{ck} = 3 \text{ ksi} \rightarrow 3000 \text{ psi}$ ,22.5.5.1.1  $V_{c,max}$  - Max shear strength of concrete

$$V_{c,max} = 5 \lambda_s \sqrt{f'_{ck}} b_w d$$

$$V_{c,max} = 5 \times (0.64282) \times \sqrt{(3000 \text{ psi})} \times (48 \text{ in}) \times (38.4 \text{ in})$$

$$V_{c,max} = 324.49 \text{ kip}$$

The following variables were converted to be consistent with empirical formula  $f'_{ck} = 3 \text{ ksi} \rightarrow 3000 \text{ psi}$ ,  $P = 10.325 \text{ kip} \rightarrow 10325 \text{ lbf}$ ,22.5.5.1.1(a)  $V_{c,a}$  - Shear strength of concrete (a)

$$V_{c,a} = \left[ 2 \lambda_s \sqrt{f'_{ck}} + \frac{P}{6 A_g} \right] b_w d$$

$$V_{c,a} = \left[ 2 \times (0.64282) \times \sqrt{(3000 \text{ psi})} + \frac{(10325 \text{ lbf})}{6 \times (2304 \text{ in}^2)} \right] \times (48 \text{ in}) \times (38.4 \text{ in})$$

$$V_{c,a} = 131.17 \text{ kip}$$

The following variables were converted to be consistent with empirical formula  $f'_{ck} = 3 \text{ ksi} \rightarrow 3000 \text{ psi}$ ,22.5.5.1.2  $V_{c,b}$  - Shear strength of concrete (b)

$$V_{c,b} = \left[ 2 \lambda_s \sqrt{f'_{ck}} + (0.05 f'_{ck}) \right] b_w d$$

$$V_{c,b} = \left[ 2 \times (0.64282) \times \sqrt{(3000 \text{ psi})} + (0.05 \times (3000 \text{ psi})) \right] \times (48 \text{ in}) \times (38.4 \text{ in})$$

$$V_{c,b} = 406.27 \text{ kip}$$

 $V_c$  - Governing shear strength of concrete

$$V_c = \text{Min}[V_{c,max}, V_{c,a}, V_{c,b}]$$

$$V_c = \text{Min}[(324.49 \text{ kip}), (131.17 \text{ kip}), (406.27 \text{ kip})]$$

$$V_c = 131.17 \text{ kip}$$

<p>22.5.1.2</p>	<p>The following variables were converted to be consistent with empirical formula <math>f'_{ck} = 3 \text{ ksi} \rightarrow 3000 \text{ psi}</math>.</p> <p><math>V_{s,a}</math> - Shear strength of steel (a)</p> $V_{s,a} = 8 \sqrt{f'_{ck}} b_w d$ $V_{s,a} = 8 \times \sqrt{(3000 \text{ psi})} \times (48 \text{ in}) \times (38.4 \text{ in})$ $V_{s,a} = 807.65 \text{ kip}$ <p><math>A_v</math> - Ties rebar area,</p> $A_v = \frac{\pi d_{ties}^2}{4}$ $A_v = \frac{\pi \times (0.375 \text{ in})^2}{4}$ $A_v = 0.11045 \text{ in}^2$ <p>22.5.8.5.3 <math>V_{s,b}</math> - Shear strength of steel (b)</p> $V_{s,b} = \frac{2 A_v f_{ywk} d}{s_{ties}}$ $V_{s,b} = \frac{2 \times (0.11045 \text{ in}^2) \times (60 \text{ ksi}) \times (38.4 \text{ in})}{(10 \text{ in})}$ $V_{s,b} = 50.894 \text{ kip}$ <p><math>V_s</math> - Governing shear strength of steel</p> $V_s = \text{MIN}[V_{s,a}, V_{s,b}]$ $V_s = \text{MIN}[(807.65 \text{ kip}), (50.894 \text{ kip})]$ $V_s = 50.894 \text{ kip}$ <p>22.5.1.1 <math>\phi V_n</math> - Allowable shear strength</p> $\phi V_n = \phi (V_c + V_s)$ $\phi V_n = (0.65) \times ((131.17 \text{ kip}) + (50.894 \text{ kip}))$ $\phi V_n = 118.34 \text{ kip}$ <p><b>Considering x-direction:</b></p> <p><math>V_{max} = 14.373 \text{ kip}</math> - Maximum shear force in the x-direction,  <b>Ratio</b> - Capacity</p> $\text{Ratio} = \frac{V_{max}}{\phi V_n}$ $\text{Ratio} = \frac{(14.373 \text{ kip})}{(118.34 \text{ kip})}$ $\text{Ratio} = 0.12146$	<p>Status: <b>PASS</b>  Ratio: <b>0.120</b></p>
<p>14.5.2.1b</p>	<p><b>Flexural Strength (ACI 318-19, LRFD)</b></p> <p><math>S_m</math> - Section modulus</p> $S_m = \frac{b D^2}{6}$ $S_m = \frac{(48 \text{ in}) \times (48 \text{ in})^2}{6}$ $S_m = 18432 \text{ in}^3$ <p><math>\lambda = 1</math> - Concrete modification factor (Normal concrete),  Allowable flexural strength:  <math>M_n</math> shall be the lesser of:</p> <p><math>\phi M_{n,1}</math></p> $\phi M_{n,1} = \phi \times 5 \times \lambda \times \sqrt{f'_c} \times S_m$ $\phi M_{n,1} = 0.65 \times 5 \times 1 \times \sqrt{(3 \text{ ksi})} \times 18432.001 \text{ in}^3$ $\phi M_{n,1} = 273.423 \text{ kipft}$ <p><math>\phi M_{n,2}</math></p> $\phi M_{n,2} = 0.85 f'_c S_m$	

$$\phi M_{n,z} = \phi S_x F_y$$

$$\phi M_{n,z} = (0.65) \times 0.85 \times (3 \text{ ksi}) \times (18432 \text{ in}^3)$$

$$\phi M_{n,z} = 2545.9 \text{ kipft}$$

Therefore,

$\phi M_n$  - Allowable flexural strength,

$$\phi M_n = \text{MIN}[\phi M_{n,1}, \phi M_{n,2}]$$

$$\phi M_n = \text{MIN}[(273.42 \text{ kipft}), (2545.9 \text{ kipft})]$$

$$\phi M_n = 273.42 \text{ kipft}$$

**Considering x-direction:**

$M_{max} = 49.126 \text{ kipft}$  - Maximum moment in the x-direction,

*Ratio* - Capacity

$$\text{Ratio} = \frac{M_{max}}{\phi M_n}$$

$$\text{Ratio} = \frac{(49.126 \text{ kipft})}{(273.42 \text{ kipft})}$$

$$\text{Ratio} = 0.17967$$

Status: **PASS**  
Ratio: **0.180**