

Your Project Calculations



Project Name: Johnson-Campton-RevA

S3D Model Link:
https://platform.skyciv.com/structural?preload_name=Johnson-Campton-RevA&preload_path=Shared%20Enterprise%20Folder/MT_Solar_Projects/4_2023

Public Model Link:
https://platform.skyciv.com/structural-viewer?project_id=HbSykDpF8VtZYpxyv1YwgH7ZGcdl6QvazBASzKylUS1VcuP0xgz4fZHijyEOr

Array Specification

Product:	Beam
Unique ID:	2P-15-6TOP-HD-12-L-4Hx4W-HFEA
Duty Classification:	HD
Module Width:	39.30 in
Module Length:	71.20in
Number of Rows:	4
Number of Columns:	4
Total Number of Modules:	16
Desired Tilt Angle:	35
Front Edge Clearance:	3
Total Array Height at Tilt:	10.56 ft
Total Frame Length:	24.50 ft
Frame Weight:	1176 lbs
Array Dimensions N/S:	13.27 ft
Array Dimensions E/W:	24.07 ft
Rail Length:	159.20 in
Rail Spacing:	2.97 ft
Rail Check:	Not Checked

Support Specifications

Pole Size:	6in Pipe Sch 40
Pole Length above Grade:	6.80 ft
Number of Poles:	2
Pole Spacing:	15 ft

Foundation Specifications

Foundation Type:	Square
Foundation Dimensions:	48 x 48 in
Foundation Depth (below grade):	Pile 1: 4.50 ft Pile 2: 4.50 ft
Foundation Volume:	5.333 y ³
Foundation Result:	PASSED
Mount Twist:	0.345524 kip

Site Info

Risk Category:	I
Exposure:	B
Soil Classification:	sand
Site Location:	560 Bog Rd, Campton, NH 03223, USA
Wind Speed:	101 mph
Snow Load:	101 psf
Design Uplift Pressure:	Multiple pressures
Design Downforce Pressure:	Multiple pressures
Design Snow Pressure:	0.038872 ksf



Design Disclaimer

This software should be used for preliminary designs and should not be used as a final design unless reviewed, verified and designed by a qualified structural engineer.

AutoDesigner Input

```
{
  "product_type": "Beam",
  "project_id": "Johnson-Campton-RevA",
  "site_address": "560 Bog Rd, Campton, NH 03223, USA",
  "module_width": 39.3,
  "module_length": 71.2,
  "number_rows": 4,
  "number_columns": 4,
  "pole_mount_section": "4_40",
  "core_pipe_width": 65,
  "core_pipe_section": "2_40",
  "adjuster_section": "2_40",
  "core_beam_height": 65,
  "core_beam_section": "HSS3x2x1/8",
  "main_pipe_section": "2_12GA",
  "pole_spacing": 15,
  "tilt_angle": 35,
  "ground_clearance": 3,
  "risk_category": "I",
  "exposure_category": "B",
  "frame_duty_override": "auto",
  "pole_override": "auto",
  "soil_type": "sand",
  "foundation_type": "Square",
  "foundation_size": 48,
  "check_rails": false,
  "wind_speed_override": 101,
  "snow_load_override": 101,
  "direct_snow_load": false
}
```

Design Notes:

- AISC Deflection checks are set to L/1 due to structure design intent
- Foundation Design and Sizing is approximate only

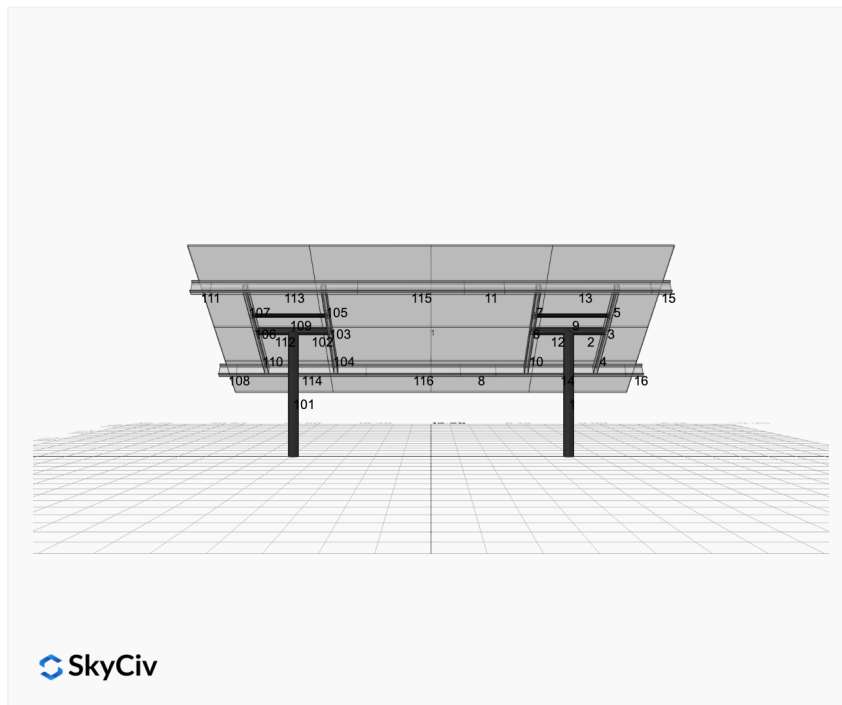

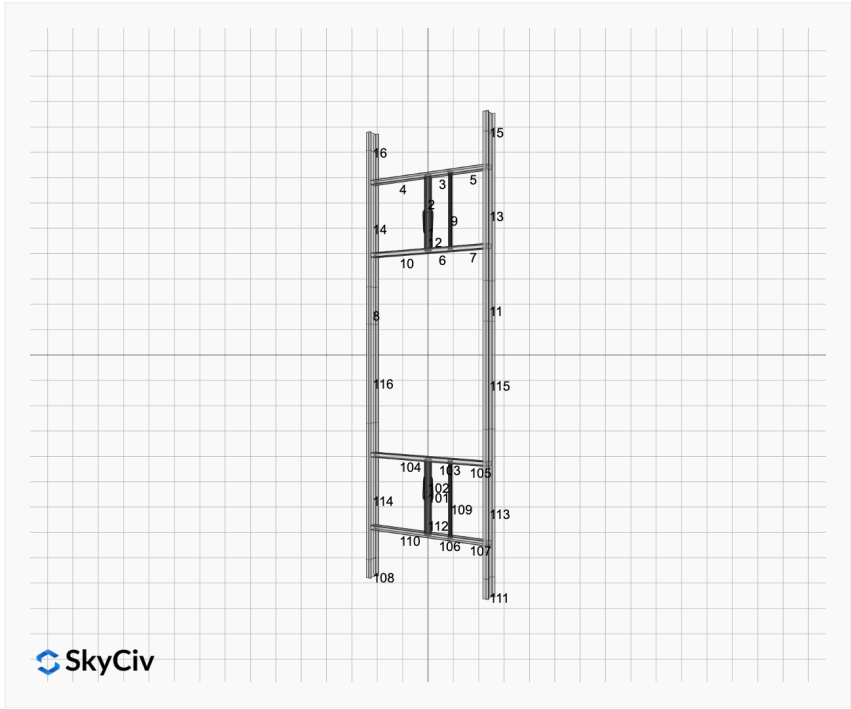
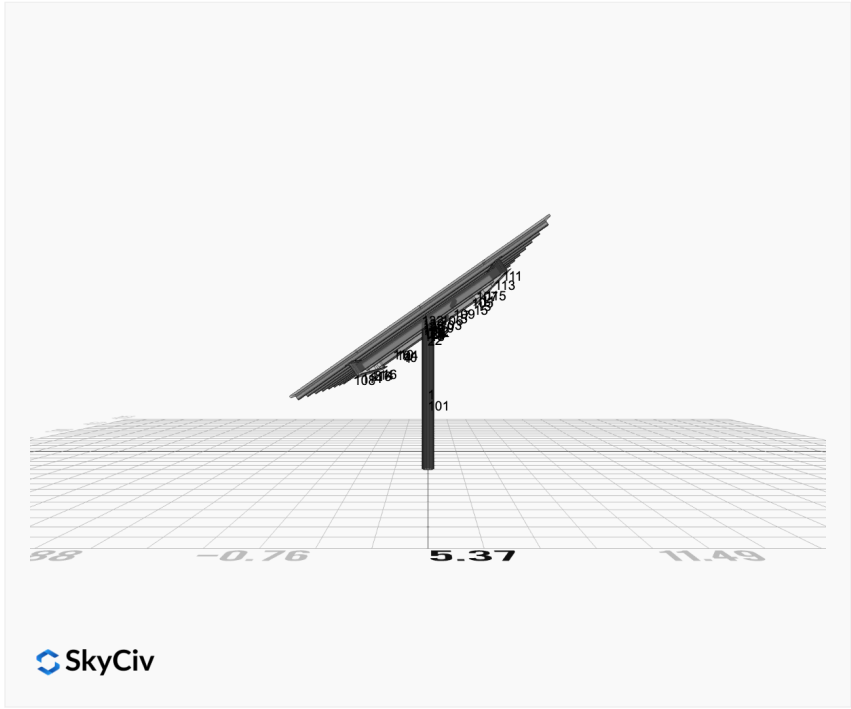

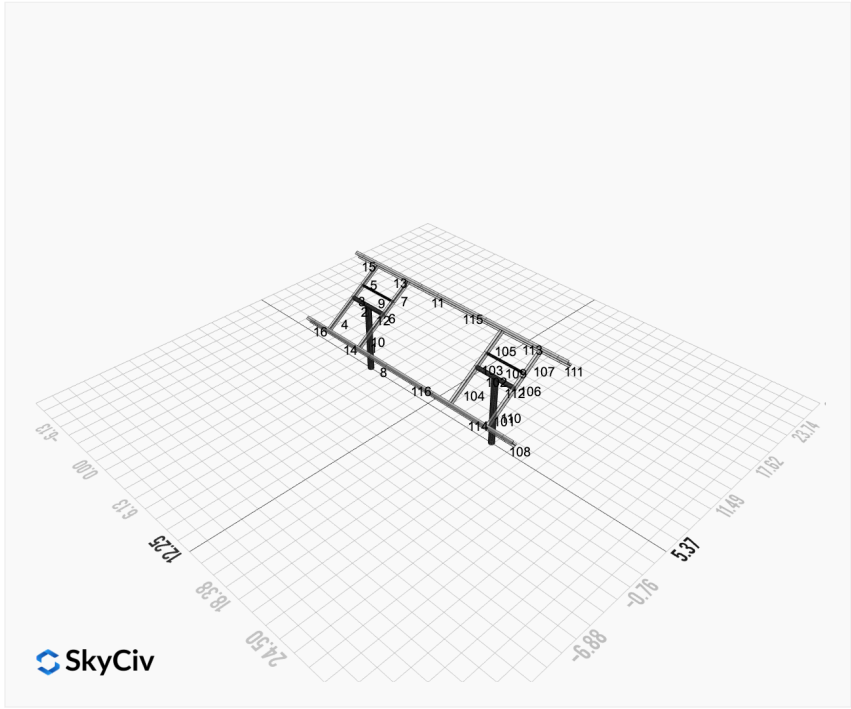

FEM Results (Envelope Worst Case for each member)

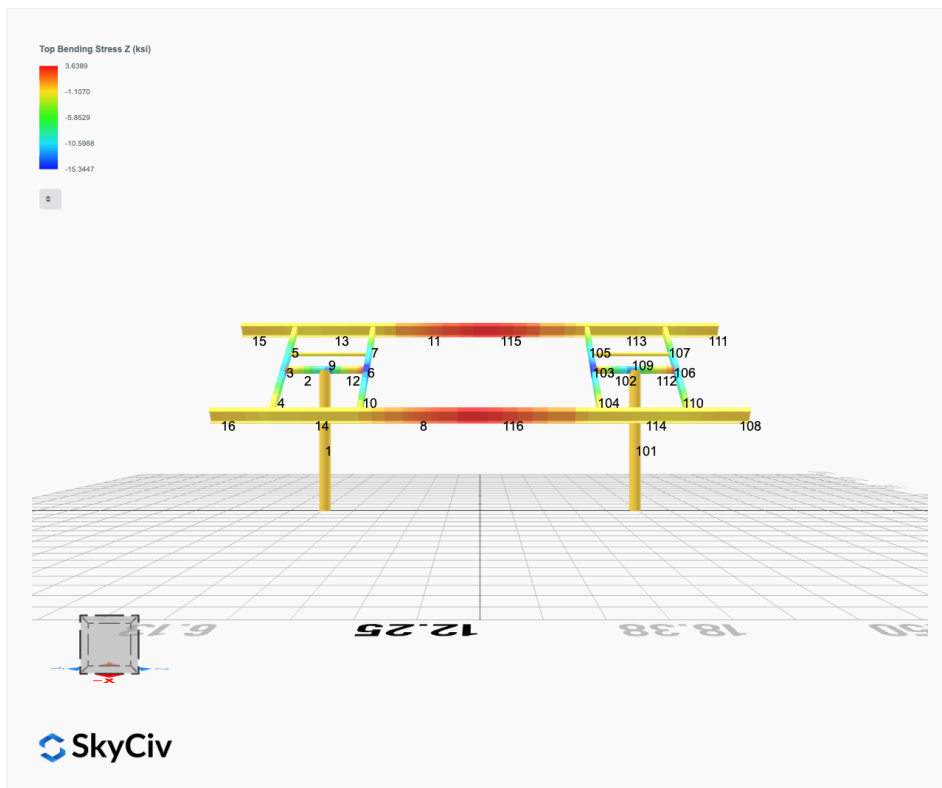
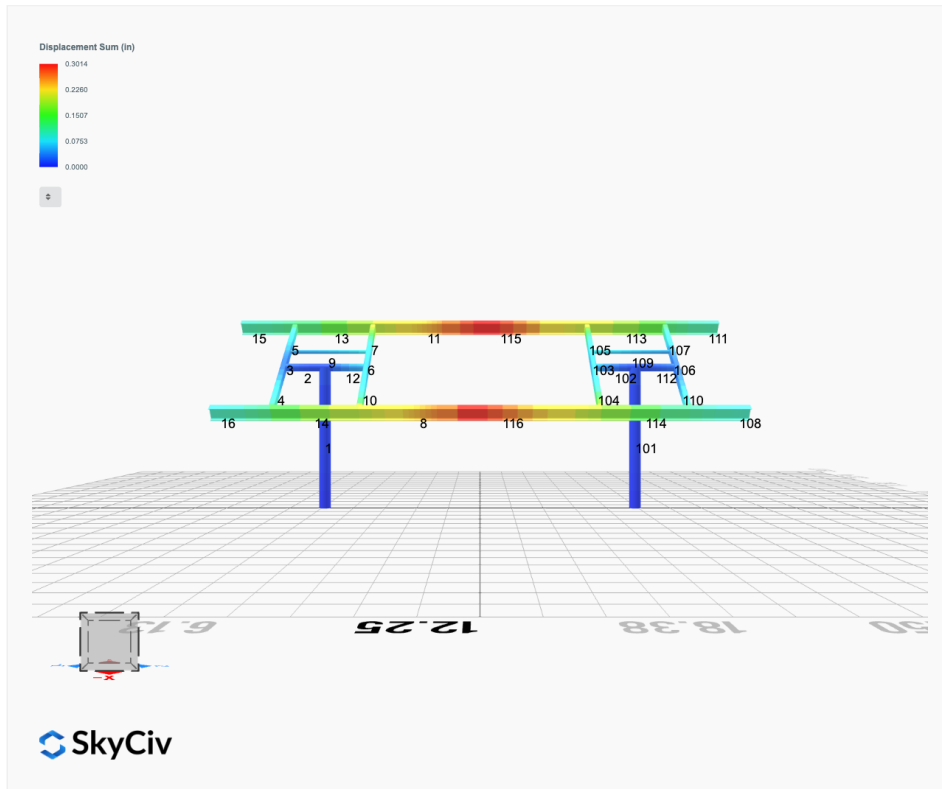

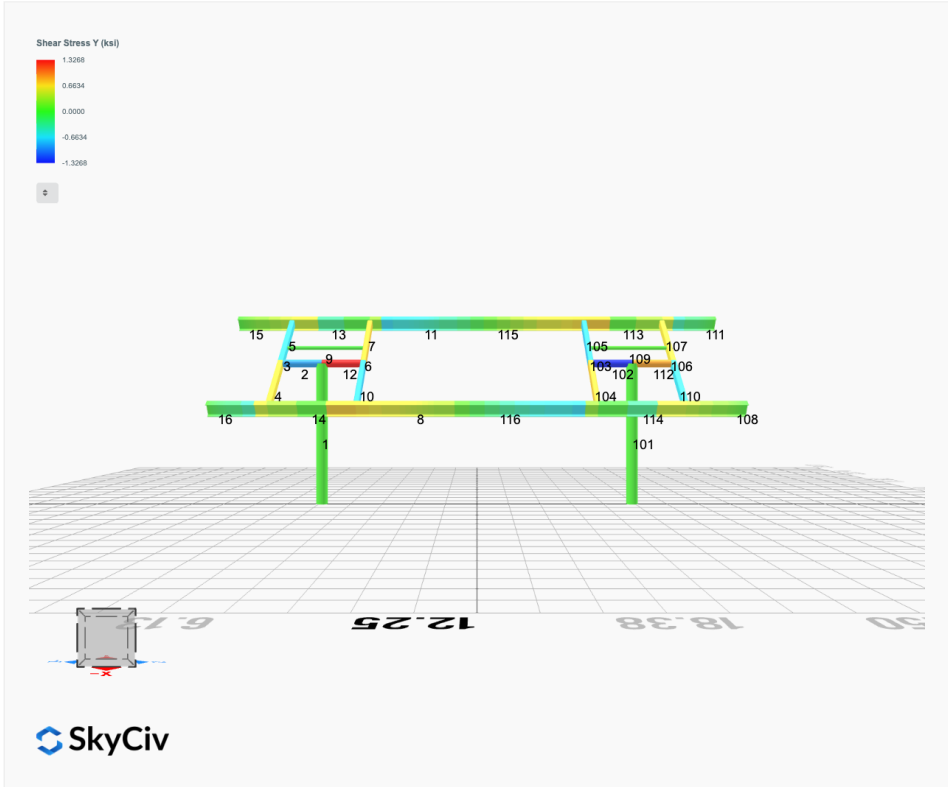
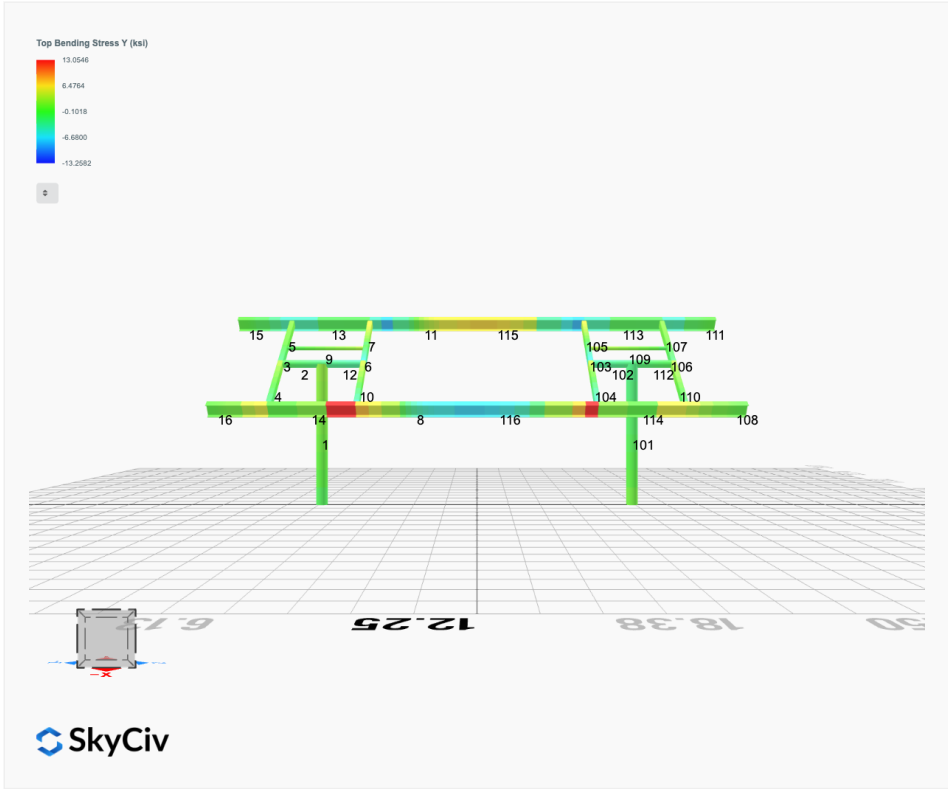

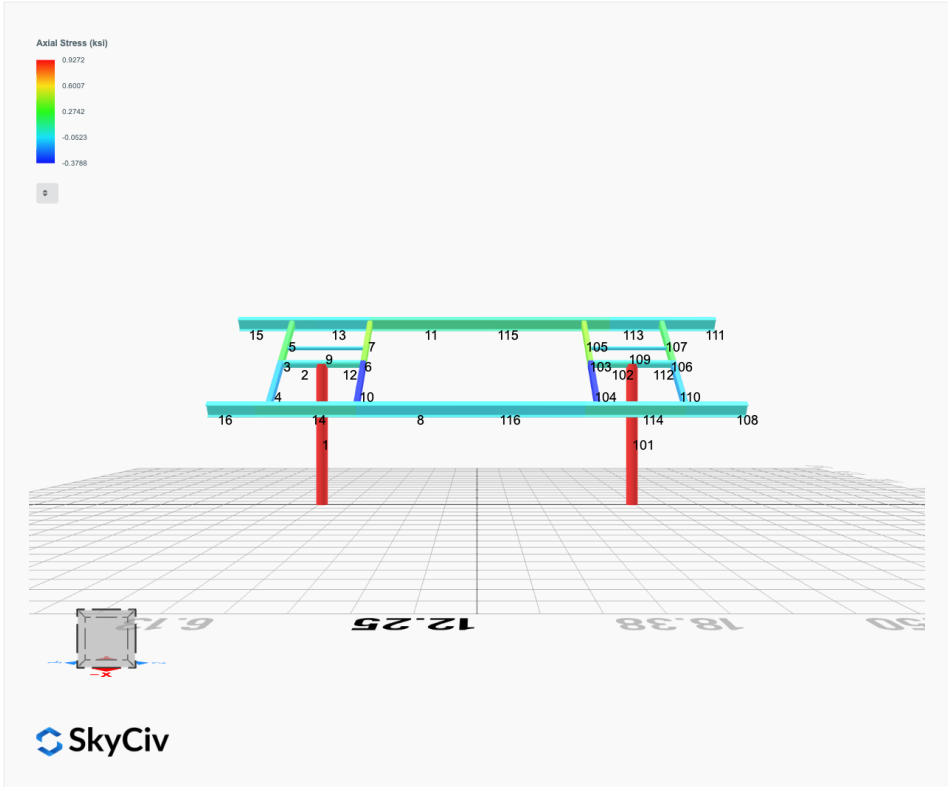

Reaction Forces for Foundation 1 (Node ID#1), (kip, kip-ft)

ASD Load Combination Results

Name	Fx	Fy	Fz	Mx	My	Mz
ULS: 1. D	0.0000	1.3464	0.0482	0.0869	-0.0215	0.0242
ULS: 2. D + L	0.0000	1.3464	0.0482	0.0869	-0.0215	0.0242
ULS: 3. D + (S or Lr or R)	0.0000	6.5212	0.2985	0.5389	-0.1342	0.0579
ULS: 3. D + (S or Lr or R)	0.0000	1.3464	0.0482	0.0869	-0.0215	0.0242
ULS: 4. D + 0.75L + 0.75(S or Lr or R)	0.0000	5.2275	0.2359	0.4259	-0.1060	0.0495
ULS: 4. D + 0.75L + 0.75(S or Lr or R)	0.0000	1.3464	0.0482	0.0869	-0.0215	0.0242
ULS: 5b. D + 0.7E	0.0000	1.3464	0.0482	0.0869	-0.0215	0.0242
ULS: 6b. D + 0.75L + 0.75(0.7)E + 0.75S	0.0000	5.2275	0.2359	0.4259	-0.1060	0.0495
ULS: 8. 0.6D + 0.7E	0.0000	0.8078	0.0289	0.0521	-0.0129	0.0145
ULS: 5a. D + 0.6W_Wind downforce Case A only	-1.2259	3.0971	0.1459	0.2509	-0.1797	8.5597
ULS: 5a. D + 0.6W_Wind downforce Case B only	-1.2259	3.0971	0.1459	0.2509	-0.1797	8.5597
ULS: 5a. D + 0.6W_Wind uplift Case A only	1.0343	-0.1308	-0.0340	-0.0510	0.1119	-6.9674
ULS: 5a. D + 0.6W_Wind uplift Case B only	0.8620	0.1154	-0.0209	-0.0290	0.0906	-9.2859
ULS: 6a. D + 0.75L + 0.75(0.6)W + 0.75(S or Lr or R)_Wind downforce Case A only	-0.9194	6.5406	0.3092	0.5489	-0.2247	6.4511
ULS: 6a. D + 0.75L + 0.75(0.6)W + 0.75(S or Lr or R)_Wind downforce Case B only	-0.9194	6.5406	0.3092	0.5489	-0.2247	6.4511
ULS: 6a. D + 0.75L + 0.75(0.6)W + 0.75(S or Lr or R)_Wind uplift Case A only	0.7758	4.1196	0.1742	0.3225	-0.0060	-5.1942
ULS: 6a. D + 0.75L + 0.75(0.6)W + 0.75(S or Lr or R)_Wind uplift Case B only	0.6465	4.3043	0.1841	0.3390	-0.0220	-6.9331
ULS: 6a. D + 0.75L + 0.75(0.6)W + 0.75(S or Lr or R)_Wind downforce Case A only	-0.9194	2.6594	0.1215	0.2099	-0.1402	6.4258
ULS: 6a. D + 0.75L + 0.75(0.6)W + 0.75(S or Lr or R)_Wind downforce Case B only	-0.9194	2.6594	0.1215	0.2099	-0.1402	6.4258
ULS: 6a. D + 0.75L + 0.75(0.6)W + 0.75(S or Lr or R)_Wind uplift Case A only	0.7758	0.2385	-0.0135	-0.0165	0.0786	-5.2195
ULS: 6a. D + 0.75L + 0.75(0.6)W + 0.75(S or Lr or R)_Wind uplift Case B only	0.6465	0.4231	-0.0036	-0.0000	0.0626	-6.9583
ULS: 7. 0.6D + 0.6W_Wind downforce Case A only	-1.2259	2.5586	0.1266	0.2161	-0.1711	8.5500
ULS: 7. 0.6D + 0.6W_Wind downforce Case B only	-1.2259	2.5586	0.1266	0.2161	-0.1711	8.5500
ULS: 7. 0.6D + 0.6W_Wind uplift Case A only	1.0343	-0.6694	-0.0533	-0.0858	0.1205	-6.9770
ULS: 7. 0.6D + 0.6W_Wind uplift Case B only	0.8620	-0.4232	-0.0402	-0.0637	0.0992	-9.2955

Worst Case Reactions LRFD

These calculations are taken directly from the FEA via SkyCiv and are used in the Concrete Checks of the Foundation Module.
Note: Worst case values are assumed as downforce wind load cases.

Result	Value (kip, kip-ft)
Axial	11.3544
Shear X	-2.0431
Shear Z	0.5411
Moment X	0.9686
Moment Y (Twist)	0.3455
Moment Z	15.6972

Worst Case Reactions ASD

These results are taken from the worst case values in the above table and are used in the Soil Checks in the Foundation Module.
Note: Worst case values are assumed as downforce wind load cases.

Result	Value (kip, kip-ft)
Axial	6.5406
Shear X	-1.2259
Shear Z	0.3092
Moment X	0.5489
Moment Y (Twist)	0.2247
Moment Z	9.2955

Reaction Forces for Foundation 2 (Node ID#101), (kip, kip-ft)

ASD Load Combination Results

Name	Fx	Fy	Fz	Mx	My	Mz
ULS: 1. D	-0.0000	1.3464	-0.0482	-0.0869	0.0215	0.0242
ULS: 2. D + L	-0.0000	1.3464	-0.0482	-0.0869	0.0215	0.0242
ULS: 3. D + (S or Lr or R)	-0.0000	6.5212	-0.2985	-0.5389	0.1343	0.0579
ULS: 3. D + (S or Lr or R)	-0.0000	1.3464	-0.0482	-0.0869	0.0215	0.0242
ULS: 4. D + 0.75L + 0.75(S or Lr or R)	-0.0000	5.2275	-0.2359	-0.4259	0.1061	0.0495
ULS: 4. D + 0.75L + 0.75(S or Lr or R)	-0.0000	1.3464	-0.0482	-0.0869	0.0215	0.0242
ULS: 5b. D + 0.7E	-0.0000	1.3464	-0.0482	-0.0869	0.0215	0.0242

Name	Fx	Fy	Fz	Mx	My	Mz
ULS: 6b. D + 0.75L + 0.75(0.7)E + 0.75S	-0.0000	5.2275	-0.2359	-0.4259	0.1061	0.0495
ULS: 8. 0.6D + 0.7E	-0.0000	0.8078	-0.0289	-0.0521	0.0129	0.0145
ULS: 5a. D + 0.6W_Wind downforce Case A only	-1.2259	3.0971	-0.1459	-0.2509	0.1797	8.5597
ULS: 5a. D + 0.6W_Wind downforce Case B only	-1.2259	3.0971	-0.1459	-0.2509	0.1797	8.5597
ULS: 5a. D + 0.6W_Wind uplift Case A only	1.0343	-0.1308	0.0340	0.0510	-0.1119	-6.9673
ULS: 5a. D + 0.6W_Wind uplift Case B only	0.8620	0.1154	0.0209	0.0290	-0.0906	-9.2859
ULS: 6a. D + 0.75L + 0.75(0.6)W + 0.75(S or Lr or R)_Wind downforce Case A only	-0.9194	6.5406	-0.3092	-0.5489	0.2248	6.4511
ULS: 6a. D + 0.75L + 0.75(0.6)W + 0.75(S or Lr or R)_Wind downforce Case B only	-0.9194	6.5406	-0.3092	-0.5489	0.2248	6.4511
ULS: 6a. D + 0.75L + 0.75(0.6)W + 0.75(S or Lr or R)_Wind uplift Case A only	0.7758	4.1196	-0.1742	-0.3225	0.0060	-5.1942
ULS: 6a. D + 0.75L + 0.75(0.6)W + 0.75(S or Lr or R)_Wind uplift Case B only	0.6465	4.3043	-0.1841	-0.3390	0.0220	-6.9331
ULS: 6a. D + 0.75L + 0.75(0.6)W + 0.75(S or Lr or R)_Wind downforce Case A only	-0.9194	2.6594	-0.1215	-0.2099	0.1402	6.4258
ULS: 6a. D + 0.75L + 0.75(0.6)W + 0.75(S or Lr or R)_Wind downforce Case B only	-0.9194	2.6594	-0.1215	-0.2099	0.1402	6.4258
ULS: 6a. D + 0.75L + 0.75(0.6)W + 0.75(S or Lr or R)_Wind uplift Case A only	0.7758	0.2385	0.0135	0.0165	-0.0786	-5.2195
ULS: 6a. D + 0.75L + 0.75(0.6)W + 0.75(S or Lr or R)_Wind uplift Case B only	0.6465	0.4231	0.0036	0.0000	-0.0626	-6.9583
ULS: 7. 0.6D + 0.6W_Wind downforce Case A only	-1.2259	2.5586	-0.1266	-0.2161	0.1711	8.5500
ULS: 7. 0.6D + 0.6W_Wind downforce Case B only	-1.2259	2.5586	-0.1266	-0.2161	0.1711	8.5500
ULS: 7. 0.6D + 0.6W_Wind uplift Case A only	1.0343	-0.6694	0.0533	0.0858	-0.1205	-6.9770
ULS: 7. 0.6D + 0.6W_Wind uplift Case B only	0.8620	-0.4232	0.0402	0.0637	-0.0992	-9.2955

Worst Case Reactions LRFD

These calculations are taken directly from the FEA via SkyCiv and are used in the Concrete Checks of the Foundation Module.
 Note: Worst case values are assumed as downforce wind load cases.

Result	Value (kip, kip-ft)
Axial	11.3544
Shear X	-2.0431
Shear Z	-0.5411
Moment X	-0.9685
Moment Y (Twist)	0.3455
Moment Z	15.6977

Worst Case Reactions ASD

These results are taken from the worst case values in the above table and are used in the Soil Checks in the Foundation Module.
 Note: Worst case values are assumed as downforce wind load cases.

Result	Value (kip, kip-ft)
Axial	6.5406
Shear X	-1.2259
Shear Z	-0.3092
Moment X	-0.5489
Moment Y (Twist)	0.2248
Moment Z	9.2955

Project Details

Design Code: AISC 360-16 LRFD
 Provision: LRFD
 Country: United States

User Name: sales@mtsolar.us
 Project Name: Johnson-Campton-RevA
 Unit System: imperial



Design Input Information

Design Factors			
Φ_t	Φ_c	Φ_b	Φ_v
0.9	0.9	0.9	0.9

Design Materials			
ID	E (ksi)	F _y (ksi)	F _u (ksi)
1	29000	50	65

Section Dimensions

ID	Name	d (in)	t _w (in)				
2	2in Pipe Sch 80	2.38	0.22				
5	4in Pipe Sch 80	4.50	0.34				
7	6in Pipe Sch 40	6.63	0.28				

ID	Name	d (in)	b (in)	t _w (in)	t _b (in)	r (in)	
16	HSS5x3x3/16	5.00	3.00	0.17	0.17	0.17	

ID	Name	d (in)	t _w (in)	b _t (in)	b _b (in)	t _t (in)	t _b (in)	r (in)
19	W8x10	7.89	0.17	3.94	3.94	0.20	0.20	0.30

Section Properties								
ID	Name	A (in ²)	J (in ⁴)	I _{yp} (in ⁴)	I _{zp} (in ⁴)	I _w (in ⁶)	S _{yp} (in ³)	S _{zp} (in ³)
2	2in Pipe Sch 80	1.48	1.74	0.87	0.87	0.00	1.02	1.02
5	4in Pipe Sch 80	4.41	19.22	9.61	9.61	0.00	5.85	5.85

115	133.20	109.71	29.25	6.12	40.24	43.62
116	133.20	109.71	28.70	6.12	40.24	43.62

Design Ratio

Member ID	P	M _z	M _y	V _y	V _z	(P,M _z ,M _y)	Worst LC	KL/r	δ	Status
1	0.069	0.371	0.064	0.027	0.007	0.381	#16	0.382	Not Required	Pass
2	0.000	0.343	0.093	0.081	0.018	0.425	#21	0.053	Not Required	Pass
3	0.010	0.524	0.053	0.052	0.016	0.577	#21	0.045	Not Required	Pass
4	0.008	0.516	0.077	0.052	0.017	0.597	#21	0.080	Not Required	Pass
5	0.009	0.325	0.031	0.052	0.005	0.339	#21	0.074	Not Required	Pass
6	0.014	0.631	0.155	0.064	0.048	0.793	#21	0.045	Not Required	Pass
7	0.015	0.391	0.151	0.063	0.037	0.430	#21	0.074	Not Required	Pass
8	0.003	0.146	0.150	0.036	0.019	0.297	#21	0.095	Not Required	Pass
9	0.004	0.049	0.086	0.002	0.005	0.113	#21	0.136	Not Required	Pass
10	0.016	0.622	0.128	0.063	0.030	0.724	#21	0.080	Not Required	Pass
11	0.006	0.146	0.148	0.036	0.019	0.296	#21	0.095	Not Required	Pass
12	0.003	0.466	0.108	0.107	0.018	0.565	#21	0.171	Not Required	Pass
13	0.007	0.080	0.352	0.053	0.028	0.373	#21	0.286	Not Required	Pass
14	0.004	0.080	0.346	0.053	0.028	0.362	#21	0.190	Not Required	Pass
15	0.000	0.006	0.018	0.010	0.005	0.024	#21	Not Required	Not Required	Pass
16	0.000	0.006	0.018	0.010	0.005	0.024	#21	Not Required	Not Required	Pass
101	0.069	0.371	0.064	0.027	0.007	0.381	#16	0.382	Not Required	Pass
102	0.003	0.466	0.108	0.107	0.018	0.565	#21	0.171	Not Required	Pass
103	0.014	0.631	0.155	0.064	0.048	0.793	#21	0.045	Not Required	Pass
104	0.016	0.622	0.128	0.063	0.030	0.724	#21	0.080	Not Required	Pass
105	0.015	0.391	0.151	0.063	0.037	0.430	#21	0.074	Not Required	Pass
106	0.010	0.524	0.053	0.052	0.016	0.578	#21	0.045	Not Required	Pass
107	0.009	0.325	0.031	0.052	0.005	0.339	#21	0.074	Not Required	Pass
108	0.000	0.006	0.018	0.010	0.005	0.024	#21	Not Required	Not Required	Pass
109	0.004	0.049	0.086	0.002	0.005	0.113	#21	0.136	Not Required	Pass
110	0.008	0.516	0.077	0.052	0.017	0.597	#21	0.080	Not Required	Pass
111	0.000	0.006	0.018	0.010	0.005	0.024	#21	Not Required	Not Required	Pass
112	0.000	0.343	0.093	0.081	0.018	0.425	#21	0.053	Not Required	Pass
113	0.007	0.080	0.352	0.053	0.028	0.373	#21	0.190	Not Required	Pass
114	0.004	0.080	0.346	0.053	0.028	0.362	#21	0.286	Not Required	Pass
115	0.007	0.183	0.198	0.036	0.019	0.384	#21	0.253	Not Required	Pass
116	0.003	0.183	0.201	0.036	0.019	0.384	#21	0.253	Not Required	Pass

Definitions

Φ _t	Safety factor for tensile
Φ _c	Safety factor for compression
Φ _b	Safety factor for flexure
Φ _v	Safety factor for shear
E	Modulus of elasticity
F _y	Specified minimum yield stress
F _u	Specified minimum tensile strength
A	Cross-sectional area
J	Torsional constant
I _{yp}	Moment of inertia about the Y axes
I _{zp}	Moment of inertia about the Z axes
I _w	Warping constant
S _{yp}	Plastic section modulus about the Y axis
S _{zp}	Plastic section modulus about the Z axis
KL	Effective length
C _n	Buckling modification factor (from all load combinations)

L_b	Length between braced points
LST	Limited slenderness for tension
LSC	Limited slenderness for compression
LD	Limited deflection
P_n	Nominal axial strength (tension/compression)
M_n	Nominal flexural strength (about Z/Y axis)
V_n	Nominal shear strength (along Z/Y axis)
P	Design ratio in case of axial force
M_z	Design ratio in case of bending about Z axis
M_y	Design ratio in case of bending about Y axis
V_y	Design ratio in case of shear along Y axis
V_z	Design ratio in case of shear along Z axis
(P, M_z , M_y)	Design ratio in case of axial force and bending action
KL/r	Design ratio in case of section slenderness
δ	Design ratio in case of member deflection
OK	Capacity is provided
NG	Capacity is not provided

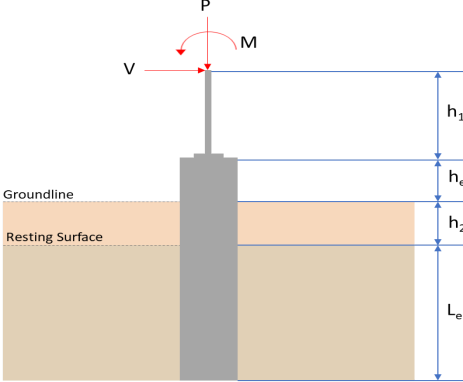
REFERENCES	CALCULATIONS	RESULTS																										
	<p>SkyCiv Foundation Design Pile Foundation</p> <p>Design Information : Design code : IBC 2021 (International Building Code) Unit System : Imperial</p>																											
	<p>Pile Input</p>  <p>Geometry Pile shape: rectangular $b = 48$ in - Pile width $D = 48$ in - Pile depth $L = 4.5$ ft - Total pile length $h_1 = 0$ ft - Lateral load height from the top of the pile, $h_2 = 0$ ft - Depth to resting surface $h_e = 0$ ft - Length of pile above the ground</p> <p>Tabulation of Soil Parameters</p> <table border="1" data-bbox="416 1102 1192 1191"> <thead> <tr> <th>Layer</th> <th>Label</th> <th>Allowable Bearing Pressure (q_a) (psf)</th> <th>Allowable Lateral Pressure (R) (psf/ft)</th> </tr> </thead> <tbody> <tr> <td>1</td> <td>Sand, silty sand, clayey sand, silty gravel & clayey gravel</td> <td>2000.000</td> <td>150.000</td> </tr> </tbody> </table> <p>Tabulation of Loads</p> <table border="1" data-bbox="676 1288 933 1458"> <thead> <tr> <th>Load Component</th> <th>ASD</th> <th>LRFD</th> </tr> </thead> <tbody> <tr> <td>P (kip)</td> <td>6.541</td> <td>11.354</td> </tr> <tr> <td>V_x (kip)</td> <td>-1.226</td> <td>-2.043</td> </tr> <tr> <td>V_z (kip)</td> <td>0.309</td> <td>0.541</td> </tr> <tr> <td>M_x (kipft)</td> <td>0.549</td> <td>0.969</td> </tr> <tr> <td>M_z (kipft)</td> <td>9.296</td> <td>15.697</td> </tr> </tbody> </table> <p>Material Properties $f'_{ck} = 3$ ksi - Concrete strength,</p>	Layer	Label	Allowable Bearing Pressure (q_a) (psf)	Allowable Lateral Pressure (R) (psf/ft)	1	Sand, silty sand, clayey sand, silty gravel & clayey gravel	2000.000	150.000	Load Component	ASD	LRFD	P (kip)	6.541	11.354	V_x (kip)	-1.226	-2.043	V_z (kip)	0.309	0.541	M_x (kipft)	0.549	0.969	M_z (kipft)	9.296	15.697	
Layer	Label	Allowable Bearing Pressure (q_a) (psf)	Allowable Lateral Pressure (R) (psf/ft)																									
1	Sand, silty sand, clayey sand, silty gravel & clayey gravel	2000.000	150.000																									
Load Component	ASD	LRFD																										
P (kip)	6.541	11.354																										
V_x (kip)	-1.226	-2.043																										
V_z (kip)	0.309	0.541																										
M_x (kipft)	0.549	0.969																										
M_z (kipft)	9.296	15.697																										
	<p>Required depth to resist lateral loads (ASD) H - Point of application of the lateral load</p> $H = h_1 + h_2 + h_e$ $H = (0 \text{ ft}) + (0 \text{ ft}) + (0 \text{ ft})$ $H = 0 \text{ ft}$ <p>Considering x-direction: H_o - Lateral force per length of pile,</p> $H_o = \frac{V_x}{1.57 D}$ $H_o = \frac{(-1.226 \text{ kip})}{1.57 \times (48 \text{ in})}$ $H_o = -0.19522 \text{ kip/ft}$ <p>M_o - Moment per length of pile,</p> $M_o = \frac{M_z + (V_x H)}{1.57 D}$																											

$$M_o = \frac{(9.296 \text{ kipft}) + ((-1.226 \text{ kip}) \times (0 \text{ ft}))}{1.57 \times (48 \text{ in})}$$

$$M_o = 1.4803 \text{ kipft/ft}$$

Required depth of embedment in earth:

$$L_x^3 - \left(14.14 \times \frac{H_o \times L_x}{R}\right) - \left(18.85 \times \frac{M_o}{R}\right) = 0$$

Solving the cubic equation:

$L_{e,x} = 4.1236 \text{ ft}$ - Required depth in x-direction,

Considering z-direction:

H_o - Lateral force per length of pile,

$$H_o = \frac{V_z}{1.57 b}$$

$$H_o = \frac{(0.309 \text{ kip})}{1.57 \times (48 \text{ in})}$$

$$H_o = 0.049204 \text{ kip/ft}$$

M_o - Moment per length of pile,

$$M_o = \frac{M_x + (V_z H)}{1.57 b}$$

$$M_o = \frac{(0.549 \text{ kipft}) + ((0.309 \text{ kip}) \times (0 \text{ ft}))}{1.57 \times (48 \text{ in})}$$

$$M_o = 0.08742 \text{ kipft/ft}$$

Required depth of embedment in earth:

$$L_z^3 - \left(14.14 \times \frac{H_o \times L_z}{R}\right) - \left(18.85 \times \frac{M_o}{R}\right) = 0$$

Solving the cubic equation:

$L_{e,z} = 2.4176 \text{ ft}$ - Required depth in z-direction,

Minimum embedded depth required:

$L_{e,req}$ - Depth of pile required,

$$L_{e,req} = \text{MAX}[L_{e,x}, L_{e,z}]$$

$$L_{e,req} = \text{MAX}[(4.1236 \text{ ft}), (2.4176 \text{ ft})]$$

$$L_{e,req} = 4.124 \text{ ft}$$

L_e - Actual embedded length of pile,

$$L_e = L - h_c - h_2$$

$$L_e = (4.5 \text{ ft}) - (0 \text{ ft}) - (0 \text{ ft})$$

$$L_e = 4.5 \text{ ft}$$

Ratio - Embedded depth

$$\text{Ratio} = \frac{L_{e,req}}{L_e}$$

$$\text{Ratio} = \frac{(4.124 \text{ ft})}{(4.5 \text{ ft})}$$

$$\text{Ratio} = 0.91644$$

Status: **PASS**
Ratio: **0.920**

End-bearing Capacity (ASD)

A - Pile cross-section area

$$A = b D$$

$$A = (48 \text{ in}) \times (48 \text{ in})$$

$$A = 16 \text{ ft}^2$$

q - End-bearing pressure

$$q = \frac{P_c}{A}$$

$$q = \frac{(6.541 \text{ kip})}{(16 \text{ ft}^2)}$$

$$q = 0.40881 \text{ kip/ft}^2$$

$$q = 0.40881 \text{ kip/ft}^2$$

Check bearing capacity ratio:

Ratio - Capacity

$$Ratio = \frac{q}{q_a}$$

$$Ratio = \frac{(0.40881 \text{ kip/ft}^2)}{(2000 \text{ psf})}$$

$$Ratio = 0.20441$$

Status: **PASS**
Ratio: **0.200**

Czerniak

Lateral Soil Pressure (ASD):

L/D - Length to least lateral dimension ratio,

$$L/D = \frac{L}{D}$$

$$L/D = \frac{(4.5 \text{ ft})}{(48 \text{ in})}$$

$$L/D = 1.125$$

Since $L/D \leq 10$,

Pile is short.

Considering x-direction:

$H_o = -0.19522 \text{ kip/ft}$ - Lateral force per length of pile,

$M_o = 1.4803 \text{ kipft/ft}$ - Overturning moment per length of pile,

a - Distance from resting surface to pivot point,

$$a = \frac{(4 M_o L_e) + (3 H_o L_e^2)}{(6 M_o) + (4 H_o L_e)}$$

$$a = \frac{(4 \times (1.4803 \text{ kipft/ft}) \times (4.5 \text{ ft})) + (3 \times (-0.19522 \text{ kip/ft}) \times (4.5 \text{ ft})^2)}{(6 \times (1.4803 \text{ kipft/ft})) + (4 \times (-0.19522 \text{ kip/ft}) \times (4.5 \text{ ft}))}$$

$$a = 3.1063 \text{ ft}$$

p - Earth pressure against the pile at distance $a/2$ from resting surface,

$$p = \frac{0.75 [(4 M_o) + (3 H_o L_e)]^2}{L_e^2 [(3 M_o) + (2 H_o L_e)]}$$

$$p = \frac{0.75 [(4 \times (1.4803 \text{ kipft/ft})) + (3 \times (-0.19522 \text{ kip/ft}) \times (4.5 \text{ ft}))]^2}{(4.5 \text{ ft})^2 [(3 \times (1.4803 \text{ kipft/ft})) + (2 \times (-0.19522 \text{ kip/ft}) \times (4.5 \text{ ft}))]}$$

$$p = 0.14897 \text{ kip/ft}^2$$

s - Earth pressure against the pile at distance L_e ,

$$s = \frac{6 [(2 M_o) + (H_o L_e)]}{L_e^2}$$

$$s = \frac{6 [(2 \times (1.4803 \text{ kipft/ft})) + ((-0.19522 \text{ kip/ft}) \times (4.5 \text{ ft}))]}{(4.5 \text{ ft})^2}$$

$$s = 0.61689 \text{ kip/ft}^2$$

Check lateral soil pressure capacity:

p_a - Allowable lateral soil pressure at depth $a/2$,

$$p_a = R \frac{a}{2}$$

$$p_a = (150 \text{ psf/ft}) \times \frac{(3.1063 \text{ ft})}{2}$$

$$p_a = 0.23297 \text{ kip/ft}^2$$

Ratio - Lateral soil capacity

$$Ratio = \frac{p}{p_a}$$

$$Ratio = \frac{(0.14897 \text{ kip/ft}^2)}{(0.23297 \text{ kip/ft}^2)}$$

$$Ratio = 0.63943$$

p_s - Allowable lateral soil pressure at depth L_e ,

Status: **PASS**
Ratio: **0.640**

	$p_s = R L_e$ $p_s = (150 \text{ psf/ft}) \times (4.5 \text{ ft})$ $p_s = 0.675 \text{ kip/ft}^2$ <p>Ratio - Lateral soil capacity</p> $\text{Ratio} = \frac{s}{p_s}$ $\text{Ratio} = \frac{(0.61689 \text{ kip/ft}^2)}{(0.675 \text{ kip/ft}^2)}$ $\text{Ratio} = 0.91391$	<p>Status: PASS Ratio: 0.910</p>
	<p>Considering z-direction:</p> <p>$H_o = 0.049204 \text{ kip/ft}$ - Lateral force per length of pile, $M_o = 0.08742 \text{ kipft/ft}$ - Overturning moment per length of pile, a - Distance from resting surface to pivot point,</p> $a = \frac{(4 M_o L_e) + (3 H_o L_e^2)}{(6 M_o) + (4 H_o L_e)}$ $a = \frac{(4 \times (0.08742 \text{ kipft/ft}) \times (4.5 \text{ ft})) + (3 \times (0.049204 \text{ kip/ft}) \times (4.5 \text{ ft})^2)}{(6 \times (0.08742 \text{ kipft/ft})) + (4 \times (0.049204 \text{ kip/ft}) \times (4.5 \text{ ft}))}$ $a = 3.2355 \text{ ft}$ <p>p - Earth pressure against the pile at distance $a/2$ from resting surface,</p> $p = \frac{0.75 [(4 M_o) + (3 H_o L_e)]^2}{L_e^2 [(3 M_o) + (2 H_o L_e)]}$ $p = \frac{0.75 \times [(4 \times (0.08742 \text{ kipft/ft})) + (3 \times (0.049204 \text{ kip/ft}) \times (4.5 \text{ ft}))]^2}{(4.5 \text{ ft})^2 \times [(3 \times (0.08742 \text{ kipft/ft})) + (2 \times (0.049204 \text{ kip/ft}) \times (4.5 \text{ ft}))]}$ $p = 0.054002 \text{ kip/ft}^2$ <p>s - Earth pressure against the pile at distance L_e,</p> $s = \frac{6 [(2 M_o) + (H_o L_e)]}{L_e^2}$ $s = \frac{6 \times [(2 \times (0.08742 \text{ kipft/ft})) + ((0.049204 \text{ kip/ft}) \times (4.5 \text{ ft}))]}{(4.5 \text{ ft})^2}$ $s = 0.11741 \text{ kip/ft}^2$ <p>Check lateral soil pressure capacity:</p> <p>p_a - Allowable lateral soil pressure at depth $a/2$,</p> $p_a = R \frac{a}{2}$ $p_a = (150 \text{ psf/ft}) \times \frac{(3.2355 \text{ ft})}{2}$ $p_a = 0.24266 \text{ kip/ft}^2$ <p>Ratio - Lateral soil capacity</p> $\text{Ratio} = \frac{p}{p_a}$ $\text{Ratio} = \frac{(0.054002 \text{ kip/ft}^2)}{(0.24266 \text{ kip/ft}^2)}$ $\text{Ratio} = 0.22254$ <p>p_s - Allowable lateral soil pressure at depth L_e,</p> $p_s = R L_e$ $p_s = (150 \text{ psf/ft}) \times (4.5 \text{ ft})$ $p_s = 0.675 \text{ kip/ft}^2$ <p>Ratio - Lateral soil capacity</p> $\text{Ratio} = \frac{s}{p_s}$	<p>Status: PASS Ratio: 0.220</p>

$$Ratio = \frac{(0.11741 \text{ kip/ft}^2)}{(0.675 \text{ kip/ft}^2)}$$

$$Ratio = 0.17394$$

Status: **PASS**
Ratio: **0.170**

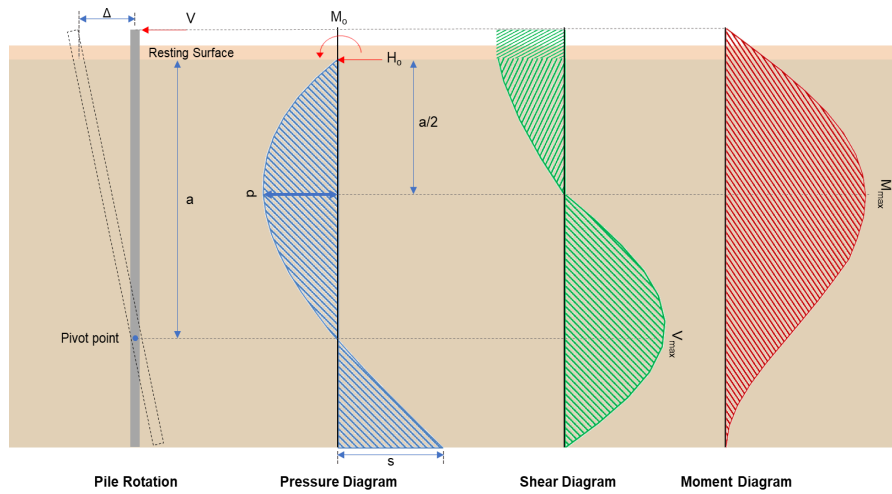

Shear force and Bending moment (x-direction, LRFD)

H_o - Lateral force per length of pile,

$$H_o = \frac{V_x}{1.57 D}$$

$$H_o = \frac{(-2.043 \text{ kip})}{1.57 \times (48 \text{ in})}$$

$$H_o = -0.32532 \text{ kip/ft}$$

M_o - Moment per length of pile,

$$M_o = \frac{M_z + (V_x H)}{1.57 D}$$

$$M_o = \frac{(15.697 \text{ kipft}) + ((-2.043 \text{ kip}) \times (0 \text{ ft}))}{1.57 \times (48 \text{ in})}$$

$$M_o = 2.4995 \text{ kipft/ft}$$

E - Distance from lateral load to resisting surface,

$$E = \frac{M_o}{H_o}$$

$$E = \frac{(2.4995 \text{ kipft/ft})}{(-0.32532 \text{ kip/ft})}$$

$$E = 7.6833 \text{ ft}$$

a - Distance from resting surface to pivot point,

$$a = \frac{(4 M_o L_c) + (3 H_o L_c^2)}{(6 M_o) + (4 H_o L_c)}$$

$$a = \frac{(4 \times (2.4995 \text{ kipft/ft}) \times (4.5 \text{ ft})) + (3 \times (-0.32532 \text{ kip/ft}) \times (4.5 \text{ ft})^2)}{(6 \times (2.4995 \text{ kipft/ft})) + (4 \times (-0.32532 \text{ kip/ft}) \times (4.5 \text{ ft}))}$$

$$a = 3.1053 \text{ ft}$$

V_{max} - Max shear force located at depth a ,

$$V_{max} = (H_o D) \left[1 - \left[3 \left(\frac{4 E}{L_c} + 3 \right) \left(\frac{a}{L_c} \right)^2 \right] + \left[4 \left(\frac{3 E}{L_c} + 2 \right) \left(\frac{a}{L_c} \right)^3 \right] \right]$$

$$V_{max} = ((-0.32532 \text{ kip/ft}) \times (48 \text{ in})) \times \left[1 - \left[3 \times \left(\frac{4 \times (7.6833 \text{ ft})}{(4.5 \text{ ft})} + 3 \right) \times \left(\frac{(3.1053 \text{ ft})}{(4.5 \text{ ft})} \right)^2 \right] + \left[4 \times \left(\frac{3 \times (7.6833 \text{ ft})}{(4.5 \text{ ft})} + 2 \right) \times \left(\frac{(3.1053 \text{ ft})}{(4.5 \text{ ft})} \right)^3 \right] \right]$$

$$V_{max} = 4.7897 \text{ kip}$$

M_{max} - Max bending moment located at depth $a/2$,

$$M_{max} = (H_o D L_e) \left[\left(\frac{E}{L_e} + \frac{a}{2 L_e} \right) - \left[\left(\frac{4E}{L_e} + 3 \right) \left(\frac{a}{2 L_e} \right)^3 + \left[\left(\frac{3E}{L_e} + 2 \right) \left(\frac{a}{2 L_e} \right)^4 \right] \right] \right]$$

$$M_{max} = ((-0.32532 \text{ kip/ft}) \times (48 \text{ in}) \times (4.5 \text{ ft})) \times \left[\left(\frac{(7.6833 \text{ ft})}{(4.5 \text{ ft})} + \frac{(3.1053 \text{ ft})}{2 \times (4.5 \text{ ft})} \right) - \left[\left(\frac{4 \times (7.6833 \text{ ft})}{(4.5 \text{ ft})} + 3 \right) \times \left(\frac{(3.1053 \text{ ft})}{2 \times (4.5 \text{ ft})} \right)^3 + \left[\left(\frac{3 \times (7.6833 \text{ ft})}{(4.5 \text{ ft})} + 2 \right) \times \left(\frac{(3.1053 \text{ ft})}{2 \times (4.5 \text{ ft})} \right)^4 \right] \right] \right]$$

$$M_{max} = 10.245 \text{ kipft}$$

Shear force and Bending moment (z-direction, LRFD)

H_o - Lateral force per length of pile,

$$H_o = \frac{V_z}{1.57 b}$$

$$H_o = \frac{(0.541 \text{ kip})}{1.57 \times (48 \text{ in})}$$

$$H_o = 0.086146 \text{ kip/ft}$$

M_o - Moment per length of pile,

$$M_o = \frac{M_x + (V_z H)}{1.57 b}$$

$$M_o = \frac{(0.969 \text{ kipft}) + ((0.541 \text{ kip}) \times (0 \text{ ft}))}{1.57 \times (48 \text{ in})}$$

$$M_o = 0.1543 \text{ kipft/ft}$$

E - Distance from lateral load to resisting surface,

$$E = \frac{M_o}{H_o}$$

$$E = \frac{(0.1543 \text{ kipft/ft})}{(0.086146 \text{ kip/ft})}$$

$$E = 1.7911 \text{ ft}$$

a - Distance from resting surface to pivot point,

$$a = \frac{(4 M_o L_e) + (3 H_o L_e^2)}{(6 M_o) + (4 H_o L_e)}$$

$$a = \frac{(4 \times (0.1543 \text{ kipft/ft}) \times (4.5 \text{ ft})) + (3 \times (0.086146 \text{ kip/ft}) \times (4.5 \text{ ft})^2)}{(6 \times (0.1543 \text{ kipft/ft})) + (4 \times (0.086146 \text{ kip/ft}) \times (4.5 \text{ ft}))}$$

$$a = 3.2348 \text{ ft}$$

V_{max} - Max shear force located at depth a ,

$$V_{max} = (H_o b) \left[1 - \left[3 \left(\frac{4E}{L_e} + 3 \right) \left(\frac{a}{L_e} \right)^2 + 4 \left(\frac{3E}{L_e} + 2 \right) \left(\frac{a}{L_e} \right)^3 \right] \right]$$

$$V_{max} = ((0.086146 \text{ kip/ft}) \times (48 \text{ in})) \times \left[1 - \left[3 \times \left(\frac{4 \times (1.7911 \text{ ft})}{(4.5 \text{ ft})} + 3 \right) \times \left(\frac{(3.2348 \text{ ft})}{(4.5 \text{ ft})} \right)^2 + 4 \times \left(\frac{3 \times (1.7911 \text{ ft})}{(4.5 \text{ ft})} + 2 \right) \times \left(\frac{(3.2348 \text{ ft})}{(4.5 \text{ ft})} \right)^3 \right] \right]$$

$$V_{max} = 0.47309 \text{ kip}$$

M_{max} - Max bending moment located at depth $a/2$,

$$M_{max} = (H_o b L_e) \left[\left(\frac{E}{L_e} + \frac{a}{2 L_e} \right) - \left[\left(\frac{4E}{L_e} + 3 \right) \left(\frac{a}{2 L_e} \right)^3 + \left[\left(\frac{3E}{L_e} + 2 \right) \left(\frac{a}{2 L_e} \right)^4 \right] \right] \right]$$

$$M_{max} = ((0.086146 \text{ kip/ft}) \times (48 \text{ in}) \times (4.5 \text{ ft})) \times \left[\left(\frac{(1.7911 \text{ ft})}{(4.5 \text{ ft})} + \frac{(3.2348 \text{ ft})}{2 \times (4.5 \text{ ft})} \right) - \left[\left(\frac{4 \times (1.7911 \text{ ft})}{(4.5 \text{ ft})} + 3 \right) \times \left(\frac{(3.2348 \text{ ft})}{2 \times (4.5 \text{ ft})} \right)^3 + \left[\left(\frac{3 \times (1.7911 \text{ ft})}{(4.5 \text{ ft})} + 2 \right) \times \left(\frac{(3.2348 \text{ ft})}{2 \times (4.5 \text{ ft})} \right)^4 \right] \right] \right]$$

$$M_{max} = 0.92656 \text{ kipft}$$

Minimum Reinforcement Check (LRFD)

Parameters:

$f'_{ck} = 3 \text{ ksi}$ - Concrete strength,
 $f_{yk} = 60 \text{ ksi}$ - Longitudinal reinforcement strength,
 $\phi = 0.65$ - Reduction factor for axial strength,
 $\alpha = 0.8$ - Alpha factor for axial strength,
 $A_g = 2304 \text{ in}^2$ - Gross area of concrete,

Table 22.4.2.1

Longitudinal reinforcement:

Required reinforcement due to axial load, $A_{st,required}$

22.4.2.2, 10.6.1.1

$A_{st,required}$

$$A_{st,required} = \text{Min} \left[\frac{\frac{P}{\phi \alpha} - (0.85 f'_{ck} A_g)}{f_{yk} - (0.85 f'_{ck})}, (0.08 A_g) \right]$$

$$A_{st,required} = \text{Min} \left[\frac{\frac{(11.354 \text{ kip})}{(0.65) \times (0.8)} - (0.85 \times (3 \text{ ksi}) \times (2304 \text{ in}^2))}{(60 \text{ ksi}) - (0.85 \times (3 \text{ ksi}))}, (0.08 \times (2304 \text{ in}^2)) \right]$$

$$A_{st,required} = -101.89 \text{ in}^2$$

A_{min} - Governing minimum reinforcement area,

$$A_{min} = \text{Max} [A_{st,required}, (0.0018 A_g)]$$

$$A_{min} = \text{Max} [(-101.89 \text{ in}^2), (0.0018 \times (2304 \text{ in}^2))]$$

$$A_{min} = 4.1472 \text{ in}^2$$

n_{rebar} - Required number of reinforcement,

$$n_{rebar} = \frac{A_{min}}{A_{rebar}}$$

$$n_{rebar} = \frac{(4.1472 \text{ in}^2)}{(0.3068 \text{ in}^2)}$$

$$n_{rebar} = 14$$

A_{st} - Actual total reinforcement area,

$$A_{st} = n_{rebar} \frac{\pi d_{bar}^2}{4}$$

$$A_{st} = (14) \times \frac{\pi \times (0.625 \text{ in})^2}{4}$$

$$A_{st} = 4.2951 \text{ in}^2$$

Ratio - Capacity

$$\text{Ratio} = \frac{A_{min}}{A_{st}}$$

$$\text{Ratio} = \frac{(4.1472 \text{ in}^2)}{(4.2951 \text{ in}^2)}$$

$$\text{Ratio} = 0.96556$$

Status: **PASS**
Ratio: **0.970**

25.2.3

s_{rebar} - Minimum spacing of reinforcement,

$$s_{rebar} = \text{Max} [1.5, (1.5 d_{bar})]$$

$$s_{rebar} = \text{Max} [1.5, (1.5 \times (0.625 \text{ in}))]$$

$$s_{rebar} = 1.5 \text{ in}$$

Ties:

25.7.2.2

Since longitudinal reinforcement is \leq No. 10: Use #3(0.375 in)

25.7.2.1

s_{ties} - Maximum spacing of ties,

$$s_{ties} = \text{Min} [(16 d_{bar}), (48 d_{ties}), \text{Min} (D, b)]$$

$$s_{ties} = \text{Min} [(16 \times (0.625 \text{ in})), (48 \times (0.375 \text{ in})), \text{Min} ((48 \text{ in}), (48 \text{ in}))]$$

$$s_{ties} = 10 \text{ in}$$

Summary:

Main reinforcement: **14 - #5 (0.625 in)**

Ties: #3(0.375 in) - 10 in

Axial Compression Strength (ACI 318-19, LRFD)

22.4.2.2

ϕP_N - Allowable axial compressive strength

$$\phi P_N = \phi 0.80 [(0.85 f'_{ck} [A_g - A_{st}]) + (f_{yk} A_{st})]$$

$$\phi P_N = (0.65) \times 0.80 \times [(0.85 \times (3 \text{ ksi}) \times [(2304 \text{ in}^2) - (4.2951 \text{ in}^2)]) + ((60 \text{ ksi}) \times (4.2951 \text{ in}^2))]$$

$$\phi P_N = 3183.4 \text{ kip}$$

Ratio - Capacity

$$\text{Ratio} = \frac{P}{\phi P_N}$$

$$\text{Ratio} = \frac{(11.354 \text{ kip})}{(3183.4 \text{ kip})}$$

$$\text{Ratio} = 0.0035666$$

Status: **PASS**
Ratio: **0.000**

Shear Strength (ACI 318-19, LRFD)

Parameters:

22.5.2.2

$b_w = 48 \text{ in}$ - Effective width,
 d - Effective depth

$$d = 0.80 D$$

$$d = 0.80 \times (48 \text{ in})$$

$$d = 38.4 \text{ in}$$

22.5.5.1.3

λ_s - size effect modification factor

$$\lambda_s = \text{MIN} \left[\sqrt{\frac{2}{1 + \frac{d}{10}}}, 1 \right]$$

$$\lambda_s = \text{MIN} \left[\sqrt{\frac{2}{1 + \frac{(38.4 \text{ in})}{10}}}, 1 \right]$$

$$\lambda_s = 0.64282$$

22.5.5.1.1

The following variables were converted to be consistent with empirical formula $f'_{ck} = 3 \text{ ksi} \rightarrow 3000 \text{ psi}$,
 $V_{c,max}$ - Max shear strength of concrete

$$V_{c,max} = 5 \lambda_s \sqrt{f'_{ck}} b_w d$$

$$V_{c,max} = 5 \times (0.64282) \times \sqrt{(3000 \text{ psi})} \times (48 \text{ in}) \times (38.4 \text{ in})$$

$$V_{c,max} = 324.49 \text{ kip}$$

22.5.5.1.1(a)

The following variables were converted to be consistent with empirical formula $f'_{ck} = 3 \text{ ksi} \rightarrow 3000 \text{ psi}$, $P = 11.354 \text{ kip} \rightarrow 11354 \text{ lbf}$,
 $V_{c,a}$ - Shear strength of concrete (a)

$$V_{c,a} = \left[2 \lambda_s \sqrt{f'_{ck}} + \frac{P}{6 A_g} \right] b_w d$$

$$V_{c,a} = \left[2 \times (0.64282) \times \sqrt{(3000 \text{ psi})} + \frac{(11354 \text{ lbf})}{6 \times (2304 \text{ in}^2)} \right] \times (48 \text{ in}) \times (38.4 \text{ in})$$

$$V_{c,a} = 131.31 \text{ kip}$$

22.5.5.1.2

The following variables were converted to be consistent with empirical formula $f'_{ck} = 3 \text{ ksi} \rightarrow 3000 \text{ psi}$,
 $V_{c,b}$ - Shear strength of concrete (b)

$$V_{c,b} = \left[2 \lambda_s \sqrt{f'_{ck}} + (0.05 f'_{ck}) \right] b_w d$$

$$V_{c,b} = \left[2 \times (0.64282) \times \sqrt{(3000 \text{ psi})} + (0.05 \times (3000 \text{ psi})) \right] \times (48 \text{ in}) \times (38.4 \text{ in})$$

$$V_{c,b} = 406.27 \text{ kip}$$

V_c - Governing shear strength of concrete

$$V_c = \text{Min}[V_{c,max}, V_{c,a}, V_{c,b}]$$

$$V_c = \text{Min}[(324.49 \text{ kip}), (131.31 \text{ kip}), (406.27 \text{ kip})]$$

$$V_c = 131.31 \text{ kip}$$

<p>22.5.1.2</p>	<p>The following variables were converted to be consistent with empirical formula $f'_{ck} = 3 \text{ ksi} \rightarrow 3000 \text{ psi}$, $V_{s,a}$ - Shear strength of steel (a)</p> $V_{s,a} = 8 \sqrt{f'_{ck}} b_w d$ $V_{s,a} = 8 \times \sqrt{(3000 \text{ psi})} \times (48 \text{ in}) \times (38.4 \text{ in})$ $V_{s,a} = 807.65 \text{ kip}$ <p>A_v - Ties rebar area,</p> $A_v = \frac{\pi d_{ties}^2}{4}$ $A_v = \frac{\pi \times (0.375 \text{ in})^2}{4}$ $A_v = 0.11045 \text{ in}^2$ <p>22.5.8.5.3 $V_{s,b}$ - Shear strength of steel (b)</p> $V_{s,b} = \frac{2 A_v f_{yties} d}{s_{ties}}$ $V_{s,b} = \frac{2 \times (0.11045 \text{ in}^2) \times (60 \text{ ksi}) \times (38.4 \text{ in})}{(10 \text{ in})}$ $V_{s,b} = 50.894 \text{ kip}$ <p>V_s - Governing shear strength of steel</p> $V_s = \text{MIN}[V_{s,a}, V_{s,b}]$ $V_s = \text{MIN}[(807.65 \text{ kip}), (50.894 \text{ kip})]$ $V_s = 50.894 \text{ kip}$ <p>22.5.1.1 ϕV_n - Allowable shear strength</p> $\phi V_n = \phi (V_c + V_s)$ $\phi V_n = (0.65) \times ((131.31 \text{ kip}) + (50.894 \text{ kip}))$ $\phi V_n = 118.43 \text{ kip}$ <p>Considering x-direction:</p> <p>$V_{max} = 4.7897 \text{ kip}$ - Maximum shear force in the x-direction, Ratio - Capacity</p> $\text{Ratio} = \frac{V_{max}}{\phi V_n}$ $\text{Ratio} = \frac{(4.7897 \text{ kip})}{(118.43 \text{ kip})}$ $\text{Ratio} = 0.040443$ <p>Considering z-direction:</p> <p>$V_{max} = 0.47309 \text{ kip}$ - Maximum shear force in the z-direction, Ratio - Capacity</p> $\text{Ratio} = \frac{V_{max}}{\phi V_n}$ $\text{Ratio} = \frac{(0.47309 \text{ kip})}{(118.43 \text{ kip})}$ $\text{Ratio} = 0.0039947$	<p>Status: PASS Ratio: 0.040</p> <p>Status: PASS Ratio: 0.000</p>
	<p>Flexural Strength (ACI 318-19, LRFD)</p> <p>S_m - Section modulus</p> $S_m = \frac{b D^2}{6}$ $S_m = \frac{(48 \text{ in}) \times (48 \text{ in})^2}{6}$ $S_m = 18432 \text{ in}^3$	

<p>14.5.2.1b</p>	<p>$\lambda = 1$ - Concrete modification factor (Normal concrete), Allowable flexural strength: M_n shall be the lesser of: $\phi M_{n,1}$</p> $\phi M_{n,1} = \phi \times 5 \times \lambda \times \sqrt{f'_c} \times S_m$ $\phi M_{n,1} = 0.65 \times 5 \times 1 \times \sqrt{3\text{ksi}} \times 18432.001\text{in}^3$ $\phi M_{n,1} = 273.423\text{kipft}$ <p>$\phi M_{n,2}$</p> $\phi M_{n,2} = \phi \times 0.85 \times f'_c \times S_m$ $\phi M_{n,2} = (0.65) \times 0.85 \times (3\text{ksi}) \times (18432\text{in}^3)$ $\phi M_{n,2} = 2545.9\text{kipft}$ <p>Therefore, ϕM_n - Allowable flexural strength,</p> $\phi M_n = \text{MIN}[\phi M_{n,1}, \phi M_{n,2}]$ $\phi M_n = \text{MIN}[(273.42\text{kipft}), (2545.9\text{kipft})]$ $\phi M_n = 273.42\text{kipft}$ <p>Considering x-direction: $M_{max} = 10.245\text{kipft}$ - Maximum moment in the x-direction, Ratio - Capacity</p> $\text{Ratio} = \frac{M_{max}}{\phi M_n}$ $\text{Ratio} = \frac{(10.245\text{kipft})}{(273.42\text{kipft})}$ $\text{Ratio} = 0.03747$	<p>Status: PASS Ratio: 0.040</p>
	<p>Considering z-direction: $M_{max} = 0.92656\text{kipft}$ - Maximum moment in the z-direction, Ratio - Capacity</p> $\text{Ratio} = \frac{M_{max}}{\phi M_n}$ $\text{Ratio} = \frac{(0.92656\text{kipft})}{(273.42\text{kipft})}$ $\text{Ratio} = 0.0033887$	<p>Status: PASS Ratio: 0.000</p>

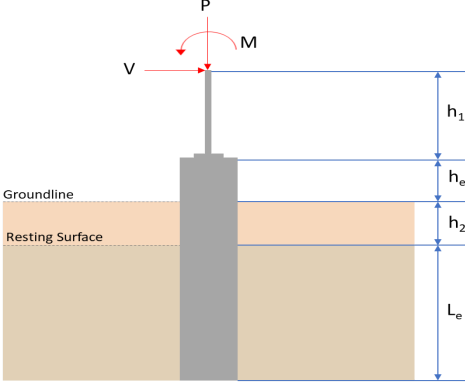
REFERENCES	CALCULATIONS	RESULTS																										
	<p>SkyCiv Foundation Design Pile Foundation</p> <p>Design Information : Design code : IBC 2021 (International Building Code) Unit System : Imperial</p>																											
	<p>Pile Input</p>  <p>Geometry</p> <p>Pile shape: rectangular $b = 48$ in - Pile width $D = 48$ in - Pile depth $L = 4.5$ ft - Total pile length $h_1 = 0$ ft - Lateral load height from the top of the pile, $h_2 = 0$ ft - Depth to resting surface $h_e = 0$ ft - Length of pile above the ground</p> <p>Tabulation of Soil Parameters</p> <table border="1" data-bbox="416 1102 1193 1191"> <thead> <tr> <th>Layer</th> <th>Label</th> <th>Allowable Bearing Pressure (q_a) (psf)</th> <th>Allowable Lateral Pressure (R) (psf/ft)</th> </tr> </thead> <tbody> <tr> <td>1</td> <td>Sand, silty sand, clayey sand, silty gravel & clayey gravel</td> <td>2000.000</td> <td>150.000</td> </tr> </tbody> </table> <p>Tabulation of Loads</p> <table border="1" data-bbox="676 1288 933 1458"> <thead> <tr> <th>Load Component</th> <th>ASD</th> <th>LRFD</th> </tr> </thead> <tbody> <tr> <td>P (kip)</td> <td>6.541</td> <td>11.354</td> </tr> <tr> <td>V_x (kip)</td> <td>-1.226</td> <td>-2.043</td> </tr> <tr> <td>V_z (kip)</td> <td>-0.309</td> <td>-0.541</td> </tr> <tr> <td>M_x (kipft)</td> <td>-0.549</td> <td>-0.968</td> </tr> <tr> <td>M_z (kipft)</td> <td>9.296</td> <td>15.698</td> </tr> </tbody> </table> <p>Material Properties</p> <p>$f'_{ck} = 3$ ksi - Concrete strength,</p>	Layer	Label	Allowable Bearing Pressure (q_a) (psf)	Allowable Lateral Pressure (R) (psf/ft)	1	Sand, silty sand, clayey sand, silty gravel & clayey gravel	2000.000	150.000	Load Component	ASD	LRFD	P (kip)	6.541	11.354	V_x (kip)	-1.226	-2.043	V_z (kip)	-0.309	-0.541	M_x (kipft)	-0.549	-0.968	M_z (kipft)	9.296	15.698	
Layer	Label	Allowable Bearing Pressure (q_a) (psf)	Allowable Lateral Pressure (R) (psf/ft)																									
1	Sand, silty sand, clayey sand, silty gravel & clayey gravel	2000.000	150.000																									
Load Component	ASD	LRFD																										
P (kip)	6.541	11.354																										
V_x (kip)	-1.226	-2.043																										
V_z (kip)	-0.309	-0.541																										
M_x (kipft)	-0.549	-0.968																										
M_z (kipft)	9.296	15.698																										
	<p>Required depth to resist lateral loads (ASD)</p> <p>H - Point of application of the lateral load</p> $H = h_1 + h_2 + h_e$ $H = (0 \text{ ft}) + (0 \text{ ft}) + (0 \text{ ft})$ $H = 0 \text{ ft}$ <p>Considering x-direction:</p> <p>H_o - Lateral force per length of pile,</p> $H_o = \frac{V_x}{1.57 D}$ $H_o = \frac{(-1.226 \text{ kip})}{1.57 \times (48 \text{ in})}$ $H_o = -0.19522 \text{ kip/ft}$ <p>M_o - Moment per length of pile,</p> $M_o = \frac{M_z + (V_x H)}{1.57 D}$																											

$$M_o = \frac{(9.296 \text{ kipft}) + ((-1.226 \text{ kip}) \times (0 \text{ ft}))}{1.57 \times (48 \text{ in})}$$

$$M_o = 1.4803 \text{ kipft/ft}$$

Required depth of embedment in earth:

$$L_x^3 - \left(14.14 \times \frac{H_o \times L_x}{R}\right) - \left(18.85 \times \frac{M_o}{R}\right) = 0$$

Solving the cubic equation:

$L_{e,x} = 4.1236 \text{ ft}$ - Required depth in x-direction,

Considering z-direction:

H_o - Lateral force per length of pile,

$$H_o = \frac{V_z}{1.57 b}$$

$$H_o = \frac{(-0.309 \text{ kip})}{1.57 \times (48 \text{ in})}$$

$$H_o = -0.049204 \text{ kip/ft}$$

M_o - Moment per length of pile,

$$M_o = \frac{M_x + (V_z H)}{1.57 b}$$

$$M_o = \frac{(0.549 \text{ kipft}) + ((-0.309 \text{ kip}) \times (0 \text{ ft}))}{1.57 \times (48 \text{ in})}$$

$$M_o = 0.08742 \text{ kipft/ft}$$

Required depth of embedment in earth:

$$L_z^3 - \left(14.14 \times \frac{H_o \times L_z}{R}\right) - \left(18.85 \times \frac{M_o}{R}\right) = 0$$

Solving the cubic equation:

$L_{e,z} = 1.4131 \text{ ft}$ - Required depth in z-direction,

Minimum embedded depth required:

$L_{e,req}$ - Depth of pile required,

$$L_{e,req} = \text{MAX}[L_{e,x}, L_{e,z}]$$

$$L_{e,req} = \text{MAX}[(4.1236 \text{ ft}), (1.4131 \text{ ft})]$$

$$L_{e,req} = 4.124 \text{ ft}$$

L_e - Actual embedded length of pile,

$$L_e = L - h_c - h_2$$

$$L_e = (4.5 \text{ ft}) - (0 \text{ ft}) - (0 \text{ ft})$$

$$L_e = 4.5 \text{ ft}$$

Ratio - Embedded depth

$$\text{Ratio} = \frac{L_{e,req}}{L_e}$$

$$\text{Ratio} = \frac{(4.124 \text{ ft})}{(4.5 \text{ ft})}$$

$$\text{Ratio} = 0.91644$$

Status: **PASS**
Ratio: **0.920**

End-bearing Capacity (ASD)

A - Pile cross-section area

$$A = b D$$

$$A = (48 \text{ in}) \times (48 \text{ in})$$

$$A = 16 \text{ ft}^2$$

q - End-bearing pressure

$$q = \frac{P_c}{A}$$

$$q = \frac{(6.541 \text{ kip})}{(16 \text{ ft}^2)}$$

$$q = 0.40881 \text{ kip/ft}^2$$

$$q = 0.40881 \text{ kip/ft}$$

Check bearing capacity ratio:

Ratio - Capacity

$$\text{Ratio} = \frac{q}{q_a}$$

$$\text{Ratio} = \frac{(0.40881 \text{ kip/ft}^2)}{(2000 \text{ psf})}$$

$$\text{Ratio} = 0.20441$$

Status: **PASS**
Ratio: **0.200**

Czerniak

Lateral Soil Pressure (ASD):

L/D - Length to least lateral dimension ratio,

$$L/D = \frac{L}{D}$$

$$L/D = \frac{(4.5 \text{ ft})}{(48 \text{ in})}$$

$$L/D = 1.125$$

Since $L/D \leq 10$,

Pile is short.

Considering x-direction:

$H_o = -0.19522 \text{ kip/ft}$ - Lateral force per length of pile,

$M_o = 1.4803 \text{ kipft/ft}$ - Overturning moment per length of pile,

a - Distance from resting surface to pivot point,

$$a = \frac{(4 M_o L_e) + (3 H_o L_e^2)}{(6 M_o) + (4 H_o L_e)}$$

$$a = \frac{(4 \times (1.4803 \text{ kipft/ft}) \times (4.5 \text{ ft})) + (3 \times (-0.19522 \text{ kip/ft}) \times (4.5 \text{ ft})^2)}{(6 \times (1.4803 \text{ kipft/ft})) + (4 \times (-0.19522 \text{ kip/ft}) \times (4.5 \text{ ft}))}$$

$$a = 3.1063 \text{ ft}$$

p - Earth pressure against the pile at distance $a/2$ from resting surface,

$$p = \frac{0.75 [(4 M_o) + (3 H_o L_e)]^2}{L_e^2 [(3 M_o) + (2 H_o L_e)]}$$

$$p = \frac{0.75 [(4 \times (1.4803 \text{ kipft/ft})) + (3 \times (-0.19522 \text{ kip/ft}) \times (4.5 \text{ ft}))]^2}{(4.5 \text{ ft})^2 [(3 \times (1.4803 \text{ kipft/ft})) + (2 \times (-0.19522 \text{ kip/ft}) \times (4.5 \text{ ft}))]}$$

$$p = 0.14897 \text{ kip/ft}^2$$

s - Earth pressure against the pile at distance L_e ,

$$s = \frac{6 [(2 M_o) + (H_o L_e)]}{L_e^2}$$

$$s = \frac{6 [(2 \times (1.4803 \text{ kipft/ft})) + ((-0.19522 \text{ kip/ft}) \times (4.5 \text{ ft}))]}{(4.5 \text{ ft})^2}$$

$$s = 0.61689 \text{ kip/ft}^2$$

Check lateral soil pressure capacity:

p_a - Allowable lateral soil pressure at depth $a/2$,

$$p_a = R \frac{a}{2}$$

$$p_a = (150 \text{ psf/ft}) \times \frac{(3.1063 \text{ ft})}{2}$$

$$p_a = 0.23297 \text{ kip/ft}^2$$

Ratio - Lateral soil capacity

$$\text{Ratio} = \frac{p}{p_a}$$

$$\text{Ratio} = \frac{(0.14897 \text{ kip/ft}^2)}{(0.23297 \text{ kip/ft}^2)}$$

$$\text{Ratio} = 0.63943$$

p_s - Allowable lateral soil pressure at depth L_e ,

Status: **PASS**
Ratio: **0.640**

$$p_s = R L_e$$

$$p_s = (150 \text{ psf/ft}) \times (4.5 \text{ ft})$$

$$p_s = 0.675 \text{ kip/ft}^2$$

Ratio - Lateral soil capacity

$$\text{Ratio} = \frac{s}{p_s}$$

$$\text{Ratio} = \frac{(0.61689 \text{ kip/ft}^2)}{(0.675 \text{ kip/ft}^2)}$$

$$\text{Ratio} = 0.91391$$

Status: **PASS**
Ratio: **0.910**

Considering z-direction:

$H_o = -0.049204 \text{ kip/ft}$ - Lateral force per length of pile,

$M_o = 0.08742 \text{ kipft/ft}$ - Overturning moment per length of pile,

a - Distance from resting surface to pivot point,

$$a = \frac{(4 M_o L_e) + (3 H_o L_e^2)}{(6 M_o) + (4 H_o L_e)}$$

$$a = \frac{(4 \times (0.08742 \text{ kipft/ft}) \times (4.5 \text{ ft})) + (3 \times (-0.049204 \text{ kip/ft}) \times (4.5 \text{ ft})^2)}{(6 \times (0.08742 \text{ kipft/ft})) + (4 \times (-0.049204 \text{ kip/ft}) \times (4.5 \text{ ft}))}$$

$$a = 3.2355 \text{ ft}$$

p - Earth pressure against the pile at distance $a/2$ from resting surface,

$$p = \frac{0.75 [(4 M_o) + (3 H_o L_e)]^2}{L_e^2 [(3 M_o) + (2 H_o L_e)]}$$

$$p = \frac{0.75 \times [(4 \times (0.08742 \text{ kipft/ft})) + (3 \times (-0.049204 \text{ kip/ft}) \times (4.5 \text{ ft}))]^2}{(4.5 \text{ ft})^2 \times [(3 \times (0.08742 \text{ kipft/ft})) + (2 \times (-0.049204 \text{ kip/ft}) \times (4.5 \text{ ft}))]}$$

$$p = -0.020296 \text{ kip/ft}^2$$

s - Earth pressure against the pile at distance L_e ,

$$s = \frac{6 [(2 M_o) + (H_o L_e)]}{L_e^2}$$

$$s = \frac{6 \times [(2 \times (0.08742 \text{ kipft/ft})) + ((-0.049204 \text{ kip/ft}) \times (4.5 \text{ ft}))]}{(4.5 \text{ ft})^2}$$

$$s = -0.0138 \text{ kip/ft}^2$$

Check lateral soil pressure capacity:

p_a - Allowable lateral soil pressure at depth $a/2$,

$$p_a = R \frac{a}{2}$$

$$p_a = (150 \text{ psf/ft}) \times \frac{(3.2355 \text{ ft})}{2}$$

$$p_a = 0.24266 \text{ kip/ft}^2$$

Ratio - Lateral soil capacity

$$\text{Ratio} = \frac{p}{p_a}$$

$$\text{Ratio} = \frac{(-0.020296 \text{ kip/ft}^2)}{(0.24266 \text{ kip/ft}^2)}$$

$$\text{Ratio} = -0.08364$$

p_s - Allowable lateral soil pressure at depth L_e ,

$$p_s = R L_e$$

$$p_s = (150 \text{ psf/ft}) \times (4.5 \text{ ft})$$

$$p_s = 0.675 \text{ kip/ft}^2$$

Ratio - Lateral soil capacity

$$\text{Ratio} = \frac{s}{p_s}$$

Status: **PASS**
Ratio: **-0.080**

$$\text{Ratio} = \frac{(-0.0138 \text{ kip/ft}^2)}{(0.675 \text{ kip/ft}^2)}$$

$$\text{Ratio} = -0.020445$$

Status: **PASS**
Ratio: **-0.020**

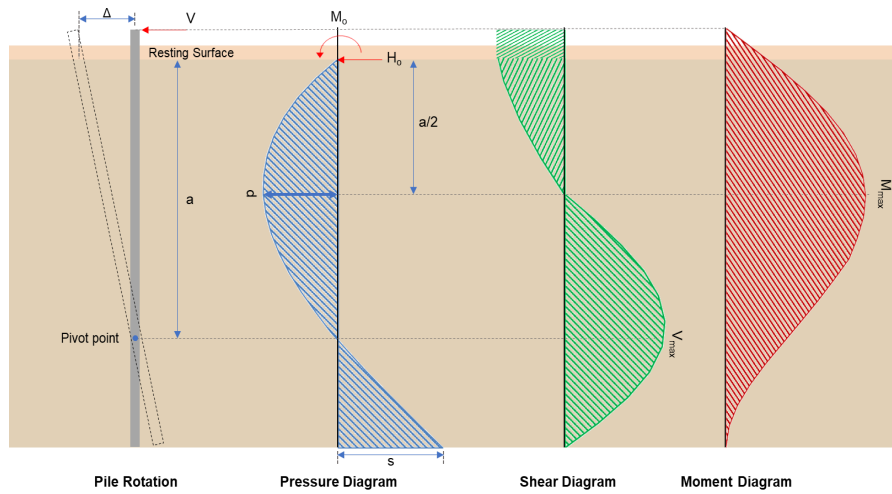

Shear force and Bending moment (x-direction, LRFD)

H_o - Lateral force per length of pile,

$$H_o = \frac{V_e}{1.57 D}$$

$$H_o = \frac{(-2.043 \text{ kip})}{1.57 \times (48 \text{ in})}$$

$$H_o = -0.32532 \text{ kip/ft}$$

M_o - Moment per length of pile,

$$M_o = \frac{M_z + (V_x H)}{1.57 D}$$

$$M_o = \frac{(15.698 \text{ kipft}) + ((-2.043 \text{ kip}) \times (0 \text{ ft}))}{1.57 \times (48 \text{ in})}$$

$$M_o = 2.4997 \text{ kipft/ft}$$

E - Distance from lateral load to resisting surface,

$$E = \frac{M_o}{H_o}$$

$$E = \frac{(2.4997 \text{ kipft/ft})}{(-0.32532 \text{ kip/ft})}$$

$$E = 7.6838 \text{ ft}$$

a - Distance from resting surface to pivot point,

$$a = \frac{(4 M_o L_e) + (3 H_o L_e^2)}{(6 M_o) + (4 H_o L_e)}$$

$$a = \frac{(4 \times (2.4997 \text{ kipft/ft}) \times (4.5 \text{ ft})) + (3 \times (-0.32532 \text{ kip/ft}) \times (4.5 \text{ ft})^2)}{(6 \times (2.4997 \text{ kipft/ft})) + (4 \times (-0.32532 \text{ kip/ft}) \times (4.5 \text{ ft}))}$$

$$a = 3.1053 \text{ ft}$$

V_{max} - Max shear force located at depth a ,

$$V_{max} = (H_o D) \left[1 - \left[3 \left(\frac{4 E}{L_e} + 3 \right) \left(\frac{a}{L_e} \right)^2 \right] + \left[4 \left(\frac{3 E}{L_e} + 2 \right) \left(\frac{a}{L_e} \right)^3 \right] \right]$$

$$V_{max} = ((-0.32532 \text{ kip/ft}) \times (48 \text{ in})) \times \left[1 - \left[3 \times \left(\frac{4 \times (7.6838 \text{ ft})}{(4.5 \text{ ft})} + 3 \right) \times \left(\frac{(3.1053 \text{ ft})}{(4.5 \text{ ft})} \right)^2 \right] + \left[4 \times \left(\frac{3 \times (7.6838 \text{ ft})}{(4.5 \text{ ft})} + 2 \right) \times \left(\frac{(3.1053 \text{ ft})}{(4.5 \text{ ft})} \right)^3 \right] \right]$$

$$V_{max} = 4.79 \text{ kip}$$

M_{max} - Max bending moment located at depth $a/2$,

$$M_{max} = (H_o D L_e) \left[\left(\frac{E}{L_e} + \frac{a}{2 L_e} \right) - \left[\left(\frac{4E}{L_e} + 3 \right) \left(\frac{a}{2 L_e} \right)^3 + \left[\left(\frac{3E}{L_e} + 2 \right) \left(\frac{a}{2 L_e} \right)^4 \right] \right] \right]$$

$$M_{max} = ((-0.32532 \text{ kip/ft}) \times (48 \text{ in}) \times (4.5 \text{ ft})) \times \left[\left(\frac{(7.6838 \text{ ft})}{(4.5 \text{ ft})} + \frac{(3.1053 \text{ ft})}{2 \times (4.5 \text{ ft})} \right) - \left[\left(\frac{4 \times (7.6838 \text{ ft})}{(4.5 \text{ ft})} + 3 \right) \times \left(\frac{(3.1053 \text{ ft})}{2 \times (4.5 \text{ ft})} \right)^3 + \left[\left(\frac{3 \times (7.6838 \text{ ft})}{(4.5 \text{ ft})} + 2 \right) \times \left(\frac{(3.1053 \text{ ft})}{2 \times (4.5 \text{ ft})} \right)^4 \right] \right] \right]$$

$$M_{max} = 10.246 \text{ kipft}$$

Shear force and Bending moment (z-direction, LRFD)

H_o - Lateral force per length of pile,

$$H_o = \frac{V_z}{1.57 b}$$

$$H_o = \frac{(-0.541 \text{ kip})}{1.57 \times (48 \text{ in})}$$

$$H_o = -0.086146 \text{ kip/ft}$$

M_o - Moment per length of pile,

$$M_o = \frac{M_x + (V_z H)}{1.57 b}$$

$$M_o = \frac{(0.968 \text{ kipft}) + ((-0.541 \text{ kip}) \times (0 \text{ ft}))}{1.57 \times (48 \text{ in})}$$

$$M_o = 0.15414 \text{ kipft/ft}$$

E - Distance from lateral load to resisting surface,

$$E = \frac{M_o}{H_o}$$

$$E = \frac{(0.15414 \text{ kipft/ft})}{(-0.086146 \text{ kip/ft})}$$

$$E = 1.7893 \text{ ft}$$

a - Distance from resting surface to pivot point,

$$a = \frac{(4 M_o L_e) + (3 H_o L_e^2)}{(6 M_o) + (4 H_o L_e)}$$

$$a = \frac{(4 \times (0.15414 \text{ kipft/ft}) \times (4.5 \text{ ft})) + (3 \times (-0.086146 \text{ kip/ft}) \times (4.5 \text{ ft})^2)}{(6 \times (0.15414 \text{ kipft/ft})) + (4 \times (-0.086146 \text{ kip/ft}) \times (4.5 \text{ ft}))}$$

$$a = 3.2349 \text{ ft}$$

V_{max} - Max shear force located at depth a ,

$$V_{max} = (H_o b) \left[1 - \left[3 \left(\frac{4E}{L_e} + 3 \right) \left(\frac{a}{L_e} \right)^2 + 4 \left(\frac{3E}{L_e} + 2 \right) \left(\frac{a}{L_e} \right)^3 \right] \right]$$

$$V_{max} = ((-0.086146 \text{ kip/ft}) \times (48 \text{ in})) \times \left[1 - \left[3 \times \left(\frac{4 \times (1.7893 \text{ ft})}{(4.5 \text{ ft})} + 3 \right) \times \left(\frac{(3.2349 \text{ ft})}{(4.5 \text{ ft})} \right)^2 + 4 \times \left(\frac{3 \times (1.7893 \text{ ft})}{(4.5 \text{ ft})} + 2 \right) \times \left(\frac{(3.2349 \text{ ft})}{(4.5 \text{ ft})} \right)^3 \right] \right]$$

$$V_{max} = 0.47285 \text{ kip}$$

M_{max} - Max bending moment located at depth $a/2$,

$$M_{max} = (H_o b L_e) \left[\left(\frac{E}{L_e} + \frac{a}{2 L_e} \right) - \left[\left(\frac{4E}{L_e} + 3 \right) \left(\frac{a}{2 L_e} \right)^3 + \left[\left(\frac{3E}{L_e} + 2 \right) \left(\frac{a}{2 L_e} \right)^4 \right] \right] \right]$$

$$M_{max} = ((-0.086146 \text{ kip/ft}) \times (48 \text{ in}) \times (4.5 \text{ ft})) \times \left[\left(\frac{(1.7893 \text{ ft})}{(4.5 \text{ ft})} + \frac{(3.2349 \text{ ft})}{2 \times (4.5 \text{ ft})} \right) - \left[\left(\frac{4 \times (1.7893 \text{ ft})}{(4.5 \text{ ft})} + 3 \right) \times \left(\frac{(3.2349 \text{ ft})}{2 \times (4.5 \text{ ft})} \right)^3 + \left[\left(\frac{3 \times (1.7893 \text{ ft})}{(4.5 \text{ ft})} + 2 \right) \times \left(\frac{(3.2349 \text{ ft})}{2 \times (4.5 \text{ ft})} \right)^4 \right] \right] \right]$$

$$M_{max} = 0.92601 \text{ kipft}$$

Minimum Reinforcement Check (LRFD)

Parameters:

$f'_{ck} = 3 \text{ ksi}$ - Concrete strength,
 $f_{yk} = 60 \text{ ksi}$ - Longitudinal reinforcement strength,
 $\phi = 0.65$ - Reduction factor for axial strength,
 $\alpha = 0.8$ - Alpha factor for axial strength,
 $A_g = 2304 \text{ in}^2$ - Gross area of concrete,

Table 22.4.2.1

Longitudinal reinforcement:

Required reinforcement due to axial load, $A_{st,required}$

22.4.2.2, 10.6.1.1

$A_{st,required}$

$$A_{st,required} = \text{Min} \left[\frac{\frac{P}{\phi \alpha} - (0.85 f'_{ck} A_g)}{f_{yk} - (0.85 f'_{ck})}, (0.08 A_g) \right]$$

$$A_{st,required} = \text{Min} \left[\frac{\frac{(11.354 \text{ kip})}{(0.65) \times (0.8)} - (0.85 \times (3 \text{ ksi}) \times (2304 \text{ in}^2))}{(60 \text{ ksi}) - (0.85 \times (3 \text{ ksi}))}, (0.08 \times (2304 \text{ in}^2)) \right]$$

$$A_{st,required} = -101.89 \text{ in}^2$$

A_{min} - Governing minimum reinforcement area,

$$A_{min} = \text{Max} [A_{st,required}, (0.0018 A_g)]$$

$$A_{min} = \text{Max} [(-101.89 \text{ in}^2), (0.0018 \times (2304 \text{ in}^2))]$$

$$A_{min} = 4.1472 \text{ in}^2$$

n_{rebar} - Required number of reinforcement,

$$n_{rebar} = \frac{A_{min}}{A_{rebar}}$$

$$n_{rebar} = \frac{(4.1472 \text{ in}^2)}{(0.3068 \text{ in}^2)}$$

$$n_{rebar} = 14$$

A_{st} - Actual total reinforcement area,

$$A_{st} = n_{rebar} \frac{\pi d_{bar}^2}{4}$$

$$A_{st} = (14) \times \frac{\pi \times (0.625 \text{ in})^2}{4}$$

$$A_{st} = 4.2951 \text{ in}^2$$

Ratio - Capacity

$$\text{Ratio} = \frac{A_{min}}{A_{st}}$$

$$\text{Ratio} = \frac{(4.1472 \text{ in}^2)}{(4.2951 \text{ in}^2)}$$

$$\text{Ratio} = 0.96556$$

Status: **PASS**
Ratio: **0.970**

25.2.3

s_{rebar} - Minimum spacing of reinforcement,

$$s_{rebar} = \text{Max} [1.5, (1.5 d_{bar})]$$

$$s_{rebar} = \text{Max} [1.5, (1.5 \times (0.625 \text{ in}))]$$

$$s_{rebar} = 1.5 \text{ in}$$

Ties:

25.7.2.2 Since longitudinal reinforcement is \leq No. 10: Use #3(0.375 in)

25.7.2.1 s_{ties} - Maximum spacing of ties,

$$s_{ties} = \text{Min} [(16 d_{bar}), (48 d_{ties}), \text{Min} (D, b)]$$

$$s_{ties} = \text{Min} [(16 \times (0.625 \text{ in})), (48 \times (0.375 \text{ in})), \text{Min} ((48 \text{ in}), (48 \text{ in}))]$$

$$s_{ties} = 10 \text{ in}$$

Summary:

Main reinforcement: **14 - #5 (0.625 in)**

Ties: #3(0.375 in) - 10 in

Axial Compression Strength (ACI 318-19, LRFD)

22.4.2.2

ϕP_N - Allowable axial compressive strength

$$\phi P_N = \phi 0.80 [(0.85 f'_{ck} [A_g - A_{st}]) + (f_{yk} A_{st})]$$

$$\phi P_N = (0.65) \times 0.80 \times [(0.85 \times (3 \text{ ksi}) \times [(2304 \text{ in}^2) - (4.2951 \text{ in}^2)]) + ((60 \text{ ksi}) \times (4.2951 \text{ in}^2))]$$

$$\phi P_N = 3183.4 \text{ kip}$$

Ratio - Capacity

$$\text{Ratio} = \frac{P}{\phi P_N}$$

$$\text{Ratio} = \frac{(11.354 \text{ kip})}{(3183.4 \text{ kip})}$$

$$\text{Ratio} = 0.0035666$$

Status: **PASS**
Ratio: **0.000**

Shear Strength (ACI 318-19, LRFD)

Parameters:

22.5.2.2

$b_w = 48 \text{ in}$ - Effective width,
 d - Effective depth

$$d = 0.80 D$$

$$d = 0.80 \times (48 \text{ in})$$

$$d = 38.4 \text{ in}$$

22.5.5.1.3

λ_s - size effect modification factor

$$\lambda_s = \text{MIN} \left[\sqrt{\frac{2}{1 + \frac{d}{10}}}, 1 \right]$$

$$\lambda_s = \text{MIN} \left[\sqrt{\frac{2}{1 + \frac{(38.4 \text{ in})}{10}}}, 1 \right]$$

$$\lambda_s = 0.64282$$

22.5.5.1.1

The following variables were converted to be consistent with empirical formula $f'_{ck} = 3 \text{ ksi} \rightarrow 3000 \text{ psi}$,
 $V_{c,max}$ - Max shear strength of concrete

$$V_{c,max} = 5 \lambda_s \sqrt{f'_{ck}} b_w d$$

$$V_{c,max} = 5 \times (0.64282) \times \sqrt{(3000 \text{ psi})} \times (48 \text{ in}) \times (38.4 \text{ in})$$

$$V_{c,max} = 324.49 \text{ kip}$$

22.5.5.1.1(a)

The following variables were converted to be consistent with empirical formula $f'_{ck} = 3 \text{ ksi} \rightarrow 3000 \text{ psi}$, $P = 11.354 \text{ kip} \rightarrow 11354 \text{ lbf}$,
 $V_{c,a}$ - Shear strength of concrete (a)

$$V_{c,a} = \left[2 \lambda_s \sqrt{f'_{ck}} + \frac{P}{6 A_g} \right] b_w d$$

$$V_{c,a} = \left[2 \times (0.64282) \times \sqrt{(3000 \text{ psi})} + \frac{(11354 \text{ lbf})}{6 \times (2304 \text{ in}^2)} \right] \times (48 \text{ in}) \times (38.4 \text{ in})$$

$$V_{c,a} = 131.31 \text{ kip}$$

22.5.5.1.2

The following variables were converted to be consistent with empirical formula $f'_{ck} = 3 \text{ ksi} \rightarrow 3000 \text{ psi}$,
 $V_{c,b}$ - Shear strength of concrete (b)

$$V_{c,b} = \left[2 \lambda_s \sqrt{f'_{ck}} + (0.05 f'_{ck}) \right] b_w d$$

$$V_{c,b} = \left[2 \times (0.64282) \times \sqrt{(3000 \text{ psi})} + (0.05 \times (3000 \text{ psi})) \right] \times (48 \text{ in}) \times (38.4 \text{ in})$$

$$V_{c,b} = 406.27 \text{ kip}$$

V_c - Governing shear strength of concrete

$$V_c = \text{Min}[V_{c,max}, V_{c,a}, V_{c,b}]$$

$$V_c = \text{Min}[(324.49 \text{ kip}), (131.31 \text{ kip}), (406.27 \text{ kip})]$$

$$V_c = 131.31 \text{ kip}$$

<p>22.5.1.2</p>	<p>The following variables were converted to be consistent with empirical formula $f'_{ck} = 3 \text{ ksi} \rightarrow 3000 \text{ psi}$, $V_{s,a}$ - Shear strength of steel (a)</p> $V_{s,a} = 8 \sqrt{f'_{ck}} b_w d$ $V_{s,a} = 8 \times \sqrt{(3000 \text{ psi})} \times (48 \text{ in}) \times (38.4 \text{ in})$ $V_{s,a} = 807.65 \text{ kip}$ <p>A_v - Ties rebar area,</p> $A_v = \frac{\pi d_{ties}^2}{4}$ $A_v = \frac{\pi \times (0.375 \text{ in})^2}{4}$ $A_v = 0.11045 \text{ in}^2$ <p>22.5.8.5.3 $V_{s,b}$ - Shear strength of steel (b)</p> $V_{s,b} = \frac{2 A_v f_{yt} d}{s_{ties}}$ $V_{s,b} = \frac{2 \times (0.11045 \text{ in}^2) \times (60 \text{ ksi}) \times (38.4 \text{ in})}{(10 \text{ in})}$ $V_{s,b} = 50.894 \text{ kip}$ <p>V_s - Governing shear strength of steel</p> $V_s = \text{MIN}[V_{s,a}, V_{s,b}]$ $V_s = \text{MIN}[(807.65 \text{ kip}), (50.894 \text{ kip})]$ $V_s = 50.894 \text{ kip}$ <p>22.5.1.1 ϕV_n - Allowable shear strength</p> $\phi V_n = \phi (V_c + V_s)$ $\phi V_n = (0.65) \times ((131.31 \text{ kip}) + (50.894 \text{ kip}))$ $\phi V_n = 118.43 \text{ kip}$ <p>Considering x-direction:</p> <p>$V_{max} = 4.79 \text{ kip}$ - Maximum shear force in the x-direction, Ratio - Capacity</p> $\text{Ratio} = \frac{V_{max}}{\phi V_n}$ $\text{Ratio} = \frac{(4.79 \text{ kip})}{(118.43 \text{ kip})}$ $\text{Ratio} = 0.040445$ <p>Considering z-direction:</p> <p>$V_{max} = 0.47285 \text{ kip}$ - Maximum shear force in the z-direction, Ratio - Capacity</p> $\text{Ratio} = \frac{V_{max}}{\phi V_n}$ $\text{Ratio} = \frac{(0.47285 \text{ kip})}{(118.43 \text{ kip})}$ $\text{Ratio} = 0.0039926$	<p>Status: PASS Ratio: 0.040</p> <p>Status: PASS Ratio: 0.000</p>
	<p>Flexural Strength (ACI 318-19, LRFD)</p> <p>S_m - Section modulus</p> $S_m = \frac{b D^2}{6}$ $S_m = \frac{(48 \text{ in}) \times (48 \text{ in})^2}{6}$ $S_m = 18432 \text{ in}^3$	

<p>14.5.2.1b</p>	<p>$\lambda = 1$ - Concrete modification factor (Normal concrete), Allowable flexural strength: M_n shall be the lesser of: $\phi M_{n,1}$</p> $\phi M_{n,1} = \phi \times 5 \times \lambda \times \sqrt{f'_c} \times S_m$ $\phi M_{n,1} = 0.65 \times 5 \times 1 \times \sqrt{3\text{ksi}} \times 18432.001\text{in}^3$ $\phi M_{n,1} = 273.423\text{kipft}$ <p>$\phi M_{n,2}$</p> $\phi M_{n,2} = \phi \times 0.85 \times f'_c \times S_m$ $\phi M_{n,2} = (0.65) \times 0.85 \times (3\text{ksi}) \times (18432\text{in}^3)$ $\phi M_{n,2} = 2545.9\text{kipft}$ <p>Therefore, ϕM_n - Allowable flexural strength,</p> $\phi M_n = \text{MIN}[\phi M_{n,1}, \phi M_{n,2}]$ $\phi M_n = \text{MIN}[(273.42\text{kipft}), (2545.9\text{kipft})]$ $\phi M_n = 273.42\text{kipft}$ <p>Considering x-direction: $M_{max} = 10.246\text{kipft}$ - Maximum moment in the x-direction, Ratio - Capacity</p> $\text{Ratio} = \frac{M_{max}}{\phi M_n}$ $\text{Ratio} = \frac{(10.246\text{kipft})}{(273.42\text{kipft})}$ $\text{Ratio} = 0.037473$	<p>Status: PASS Ratio: 0.040</p>
	<p>Considering z-direction: $M_{max} = 0.92601\text{kipft}$ - Maximum moment in the z-direction, Ratio - Capacity</p> $\text{Ratio} = \frac{M_{max}}{\phi M_n}$ $\text{Ratio} = \frac{(0.92601\text{kipft})}{(273.42\text{kipft})}$ $\text{Ratio} = 0.0033867$	<p>Status: PASS Ratio: 0.000</p>