

Your Project Calculations



Project Name: WilliamTrebs-RevA

S3D Model Link:

https://platform.skyciv.com/structural?preload_name=WilliamTrebs-RevA&preload_path=Shared%20Enterprise%20Folder/MT_Solar_Projects/3_2023

Public Model Link:

https://platform.skyciv.com/structural-viewer?project_id=pdZbLb5atzEqJbqQZcF7KbBXzF8sGBwOPAhMYxYvak524g0ihblPKJAF3EeZggP

Array Specification

Product:	Beam
Unique ID:	1P-0-10TOP-XD-72-L-4Hx3W-B8B2
Duty Classification:	XD
Module Width:	37.48 in
Module Length:	79.06in
Number of Rows:	4
Number of Columns:	3
Total Number of Modules:	12
Desired Tilt Angle:	45
Front Edge Clearance:	3
Total Array Height at Tilt:	11.89 ft
Total Frame Length:	19.50 ft
Frame Weight:	1043 lbs
Array Dimensions N/S:	12.66 ft
Array Dimensions E/W:	20.02 ft
Rail Length:	151.92 in
Rail Spacing:	3.29 ft
Rail Check:	

Support Specifications

Pole Size:	10in Pipe Sch 40
Pole Length above Grade:	7.48 ft
Number of Poles:	1
Pole Spacing:	0

Foundation Specifications

Foundation Type:	Round
Foundation Dimensions:	Ø36 in
Foundation Depth (below grade):	Pile 1: 7.75 ft
Foundation Volume:	2.029 y ³
Foundation Result:	PASSED

Site Info

Risk Category:	I
Exposure:	B
Soil Classification:	sand
Site Location:	52163 Eagle Point Rd, Bigfork, MN 56628, USA
Wind Speed:	100 mph
Snow Load:	70 psf
Design Uplift Pressure:	Multiple pressures
Design Downforce Pressure:	Multiple pressures
Design Snow Pressure:	0.013607 ksf

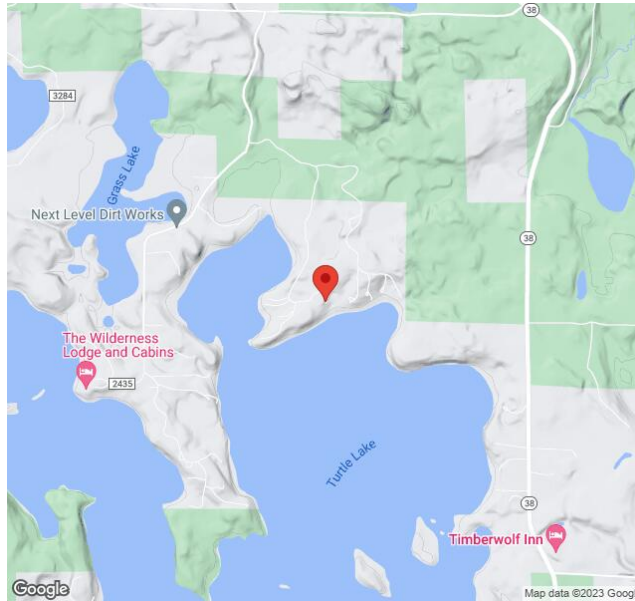

Design Disclaimer

This software should be used for preliminary designs and should not be used as a final design unless reviewed, verified and designed by a qualified structural engineer.

AutoDesigner Input

```
{
  "wind_speed_override": null,
  "snow_load_override": null,
  "direct_snow_load": false,
  "product_type": "Beam",
  "project_id": "WilliamTrebs-RevA",
  "site_address": "52163 Eagle Point Rd, Bigfork, MN 56628, USA",
  "module_width": 37.48,
  "module_length": 79.06,
  "number_rows": 4,
  "number_columns": 3,
  "pole_mount_section": "4_40",
  "core_pipe_width": 65,
  "core_pipe_section": "2_40",
  "adjuster_section": "2_40",
  "core_beam_height": 65,
  "core_beam_section": "HSS3x2x1/8",
  "main_pipe_section": "2_12GA",
  "pole_spacing": 15,
  "tilt_angle": 45,
  "ground_clearance": 3,
  "risk_category": "I",
  "exposure_category": "B",
  "frame_duty_override": "XD",
  "pole_override": "auto",
  "soil_type": "sand",
  "foundation_type": "Round",
  "foundation_size": 36,
  "check_rails": true
}
```

Design Notes:

- AISC Deflection checks are set to L/1 due to structure design intent
- Foundation Design and Sizing is approximate only

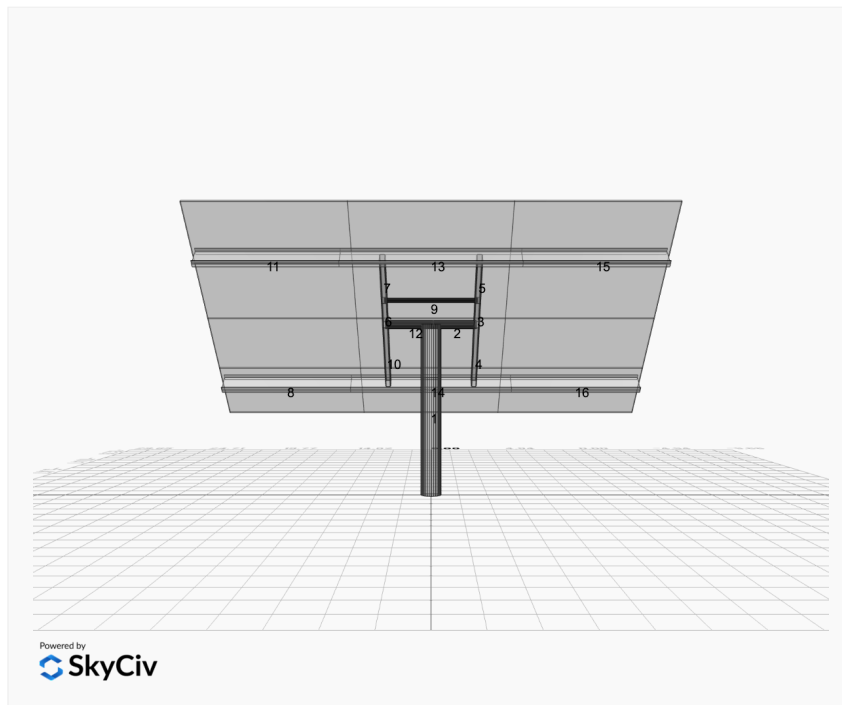

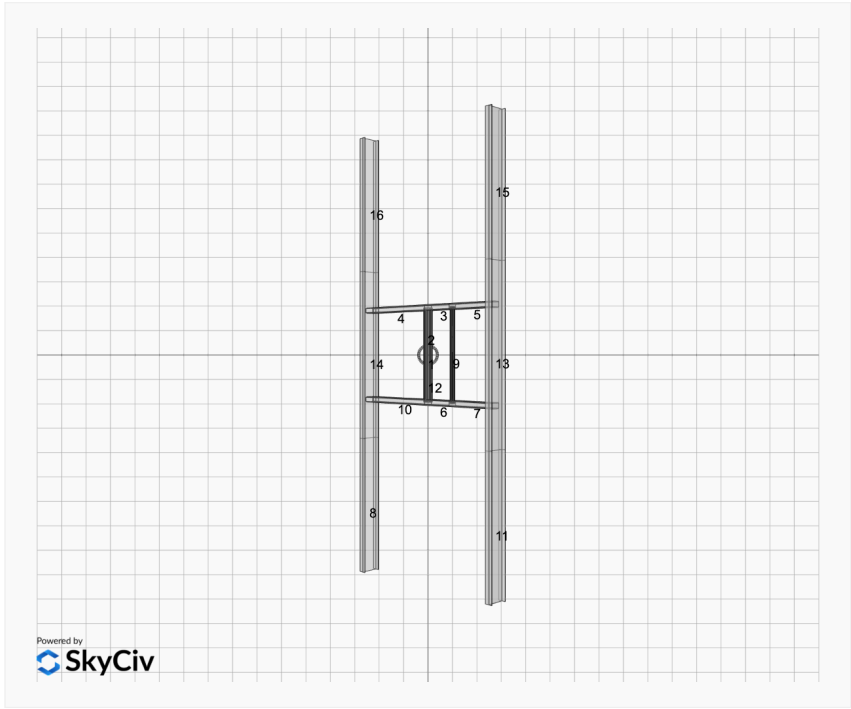
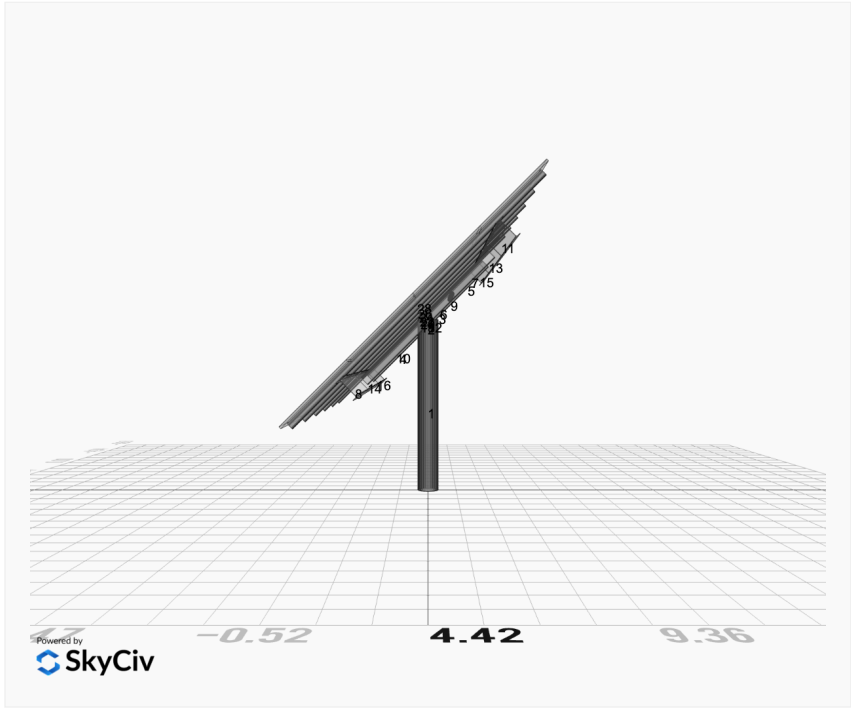

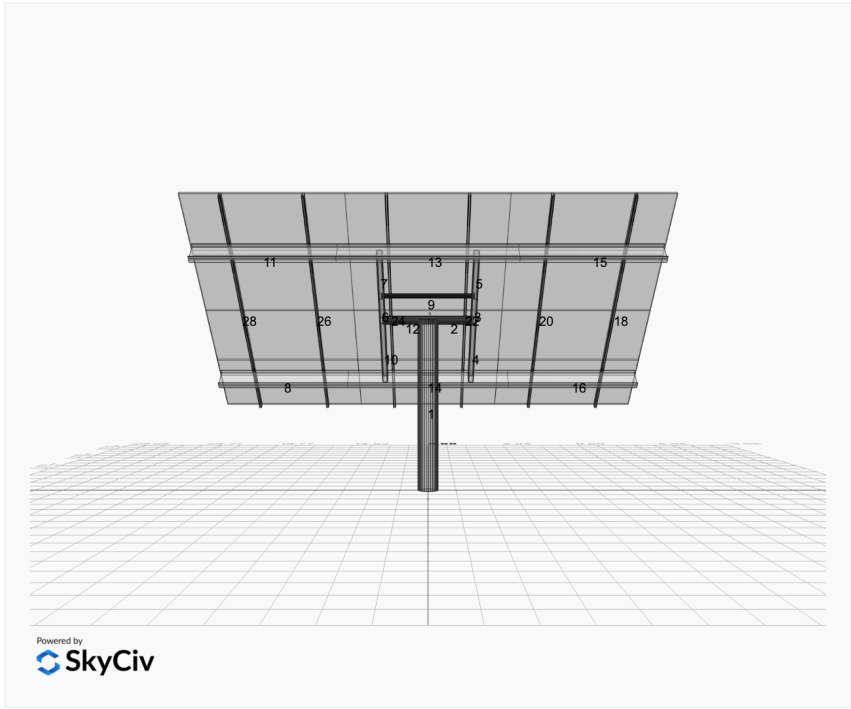
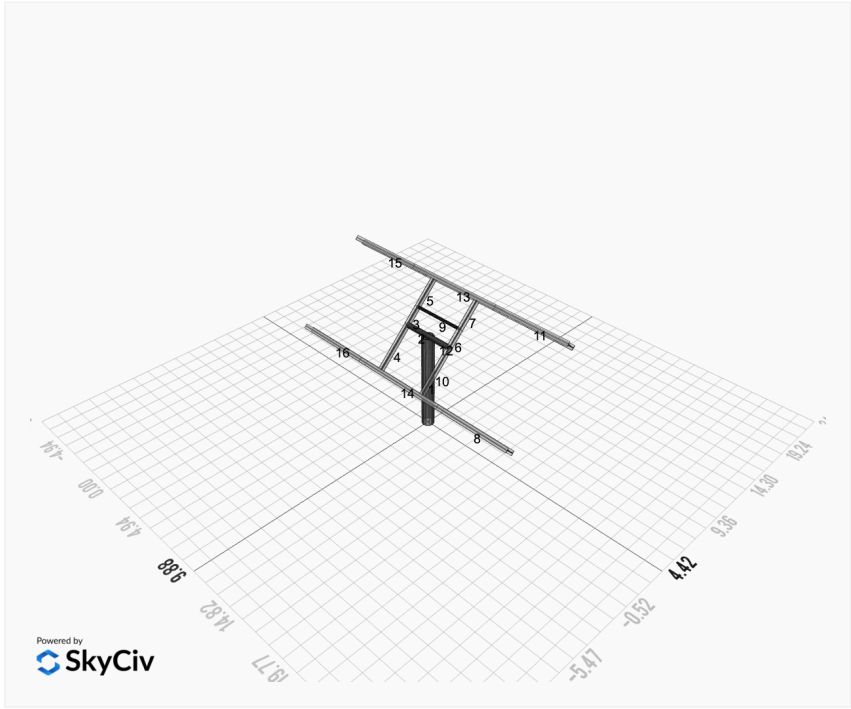

FEM Results (Envelope Worst Case for each member)

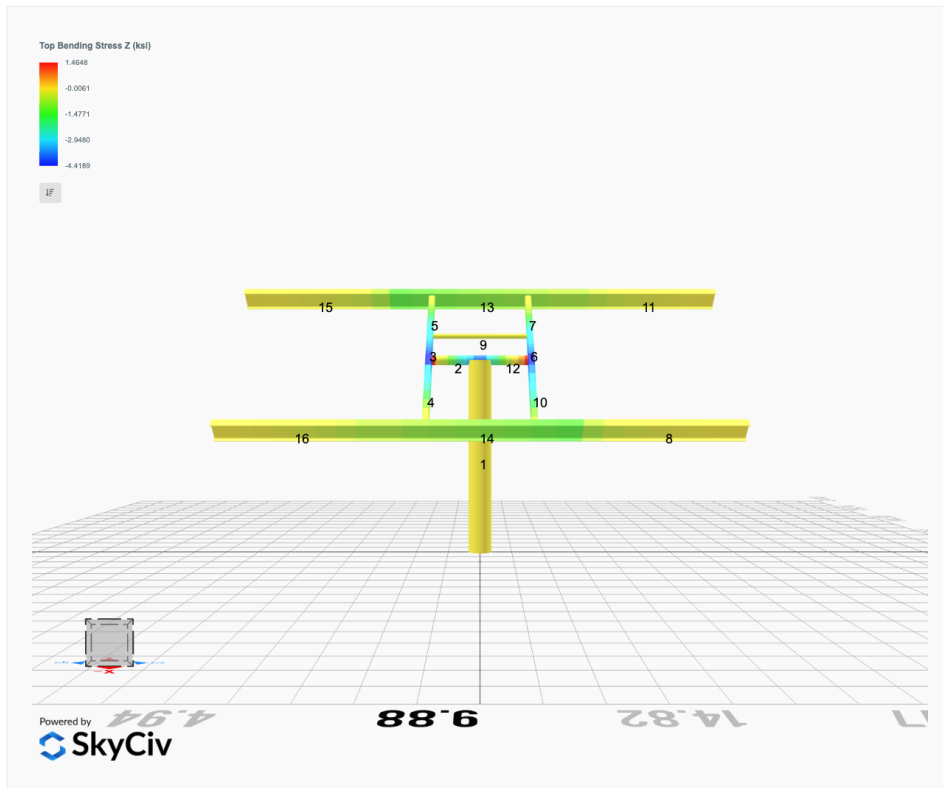
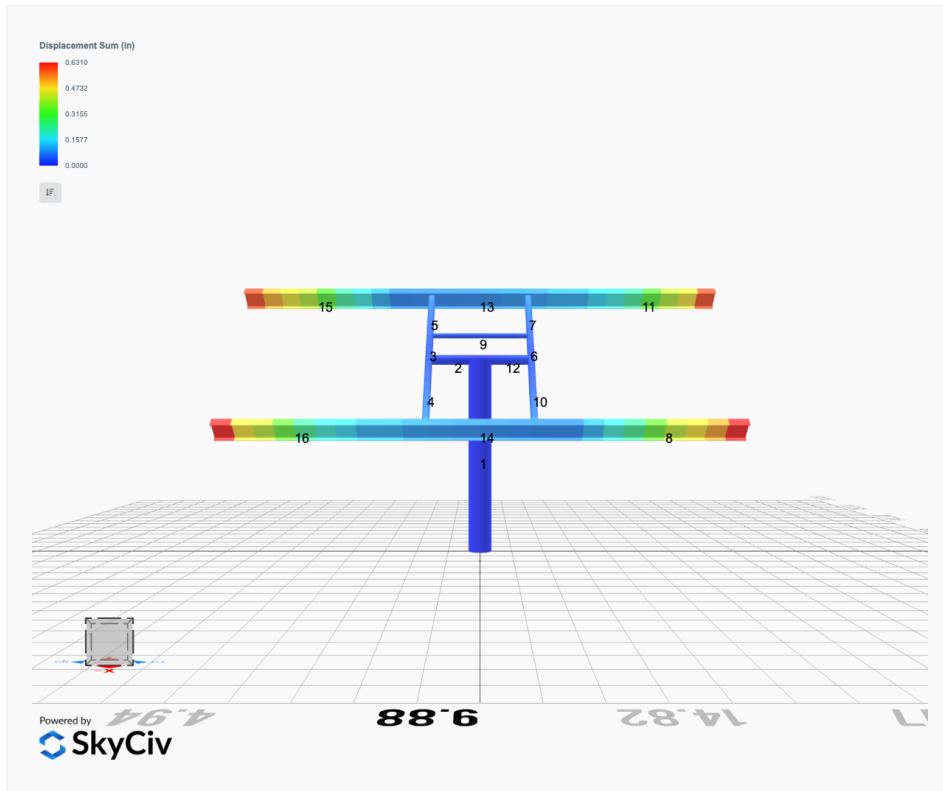

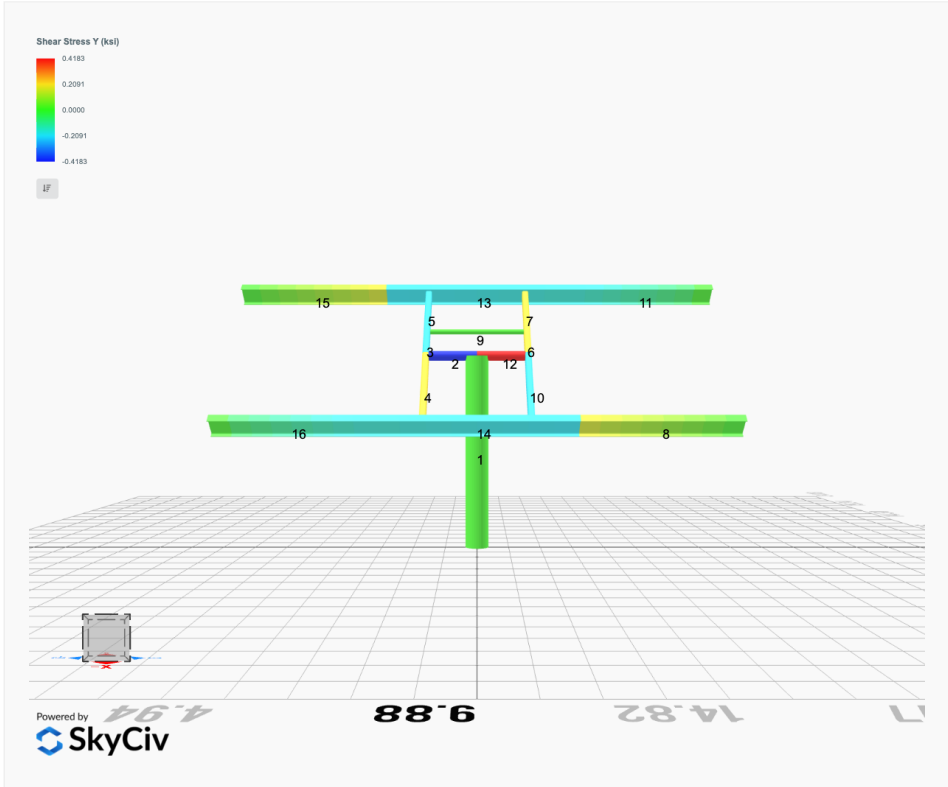
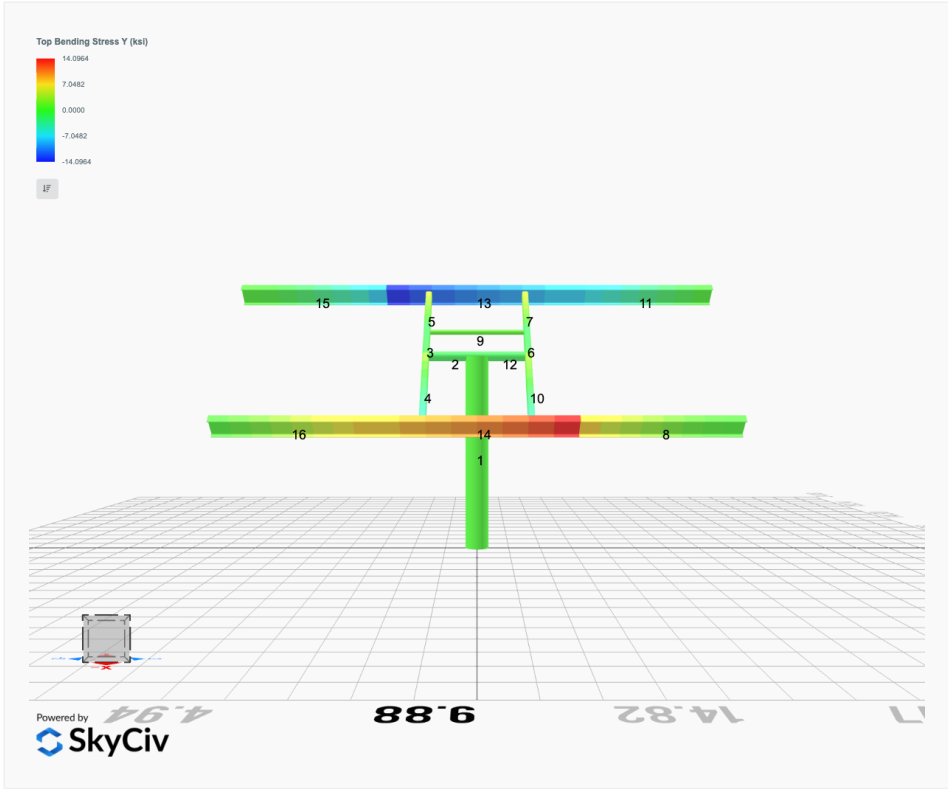

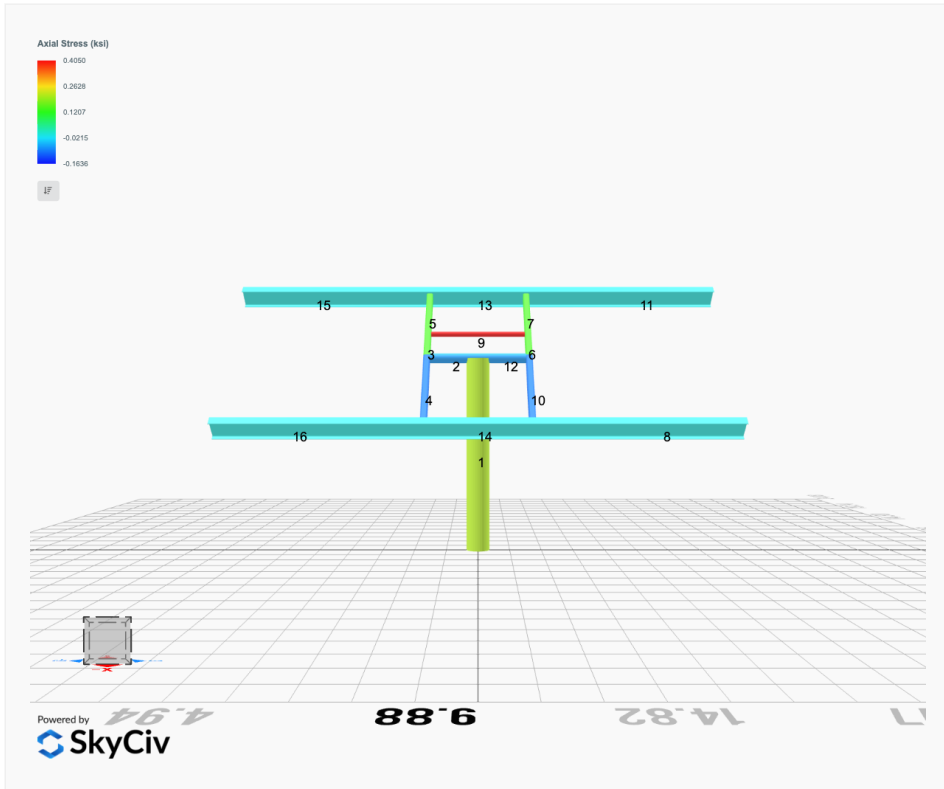

Reaction Forces for Foundation 1 (Node ID#1), (kip, kip-ft)

ASD Load Combination Results

Name	Fx	Fy	Fz	Mx	My	Mz
ULS: 1. D	0.0000	2.2369	0.0000	0.0000	-0.0000	0.0245
ULS: 2. D + L	0.0000	2.2369	0.0000	0.0000	-0.0000	0.0245
ULS: 3. D + (S or Lr or R)	0.0000	4.6123	-0.0000	0.0000	-0.0000	0.0303
ULS: 3. D + (S or Lr or R)	0.0000	2.2369	0.0000	0.0000	-0.0000	0.0245
ULS: 4. D + 0.75L + 0.75(S or Lr or R)	0.0000	4.0184	-0.0000	0.0000	-0.0000	0.0289
ULS: 4. D + 0.75L + 0.75(S or Lr or R)	0.0000	2.2369	0.0000	0.0000	-0.0000	0.0245
ULS: 5b. D + 0.7E	0.0000	2.2369	0.0000	0.0000	-0.0000	0.0245
ULS: 6b. D + 0.75L + 0.75(0.7)E + 0.75S	0.0000	4.0184	-0.0000	0.0000	-0.0000	0.0289
ULS: 8. 0.6D + 0.7E	0.0000	1.3422	0.0000	0.0000	-0.0000	0.0147
ULS: 5a. D + 0.6W_Wind downforce Case A only	-2.5543	4.7913	-0.0000	0.0000	-0.0000	20.0354
ULS: 5a. D + 0.6W_Wind downforce Case B only	-2.5543	4.7913	-0.0000	0.0000	-0.0000	20.0354
ULS: 5a. D + 0.6W_Wind uplift Case A only	1.8478	0.3891	-0.0000	0.0000	-0.0000	-13.1903
ULS: 5a. D + 0.6W_Wind uplift Case B only	1.6304	0.6065	-0.0000	0.0000	-0.0000	-16.7462
ULS: 6a. D + 0.75L + 0.75(0.6)W + 0.75(S or Lr or R)_Wind downforce Case A only	-1.9157	5.9342	-0.0000	0.0000	-0.0000	15.0370
ULS: 6a. D + 0.75L + 0.75(0.6)W + 0.75(S or Lr or R)_Wind downforce Case B only	-1.9157	5.9342	-0.0000	0.0000	-0.0000	15.0370
ULS: 6a. D + 0.75L + 0.75(0.6)W + 0.75(S or Lr or R)_Wind uplift Case A only	1.3859	2.6326	-0.0000	0.0000	-0.0000	-9.8823
ULS: 6a. D + 0.75L + 0.75(0.6)W + 0.75(S or Lr or R)_Wind uplift Case B only	1.2228	2.7956	-0.0000	0.0000	-0.0000	-12.5492
ULS: 6a. D + 0.75L + 0.75(0.6)W + 0.75(S or Lr or R)_Wind downforce Case A only	-1.9157	4.1527	0.0000	0.0000	-0.0000	15.0327
ULS: 6a. D + 0.75L + 0.75(0.6)W + 0.75(S or Lr or R)_Wind downforce Case B only	-1.9157	4.1527	0.0000	0.0000	-0.0000	15.0327
ULS: 6a. D + 0.75L + 0.75(0.6)W + 0.75(S or Lr or R)_Wind uplift Case A only	1.3859	0.8511	-0.0000	0.0000	-0.0000	-9.8866
ULS: 6a. D + 0.75L + 0.75(0.6)W + 0.75(S or Lr or R)_Wind uplift Case B only	1.2228	1.0141	-0.0000	0.0000	-0.0000	-12.5535
ULS: 7. 0.6D + 0.6W_Wind downforce Case A only	-2.5543	3.8965	-0.0000	0.0000	-0.0000	20.0256
ULS: 7. 0.6D + 0.6W_Wind downforce Case B only	-2.5543	3.8965	-0.0000	0.0000	-0.0000	20.0256
ULS: 7. 0.6D + 0.6W_Wind uplift Case A only	1.8478	-0.5057	-0.0000	0.0000	-0.0000	-13.2001
ULS: 7. 0.6D + 0.6W_Wind uplift Case B only	1.6304	-0.2883	-0.0000	0.0000	-0.0000	-16.7560

Worst Case Reactions LRFD

These calculations are taken directly from the FEA via SkyCiv and are used in the Concrete Checks of the Foundation Module.
Note: Worst case values are assumed as downforce wind load cases.

Result	Value
Axial	8.6135
Shear X	-4.2572
Shear Z	0.0000
Moment X	0.0000
Moment Z	33.4953

Worst Case Reactions ASD

These results are taken from the worst case values in the above table and are used in the Soil Checks in the Foundation Module.
Note: Worst case values are assumed as downforce wind load cases.

Result	Value
Axial	5.9342
Shear X	-2.5543
Shear Z	-0.0000
Moment X	0.0000
Moment Z	20.0354

Project Details

Design Code: AISC 360-16 LRFD
 Provision: LRFD
 Country: United States
 User Name: sales@mtsolar.us
 Unit System: imperial



Design Input Information

Design Factors			
Φ_t	Φ_c	Φ_b	Φ_v
0.9	0.9	0.9	0.9

Design Materials			
ID	E (ksi)	F_y (ksi)	F_u (ksi)
1	29000	50	65

Section Dimensions

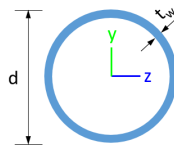

ID	Name	d (in)	t_w (in)					
3	2in Pipe Sch 120	2.38	0.25					
6	4in Pipe Sch 120	4.50	0.44					
11	10in Pipe Sch 40	10.75	0.36					

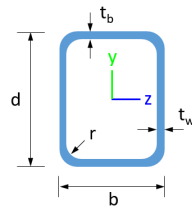

ID	Name	d (in)	b (in)	t_w (in)	t_b (in)	r (in)		
17	HSS5x3x1/4	5.00	3.00	0.23	0.23	0.23		

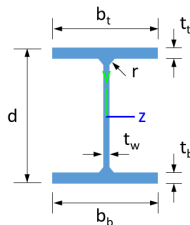

ID	Name	d (in)	t_w (in)	b_t (in)	b_b (in)	t_t (in)	t_b (in)	r (in)
20	W10x12	9.87	0.19	3.96	3.96	0.21	0.21	0.30

Section Properties

ID	Name	A (in ²)	J (in ⁴)	I_{yp} (in ⁴)	I_{zp} (in ⁴)	I_w (in ⁶)	S_{yp} (in ³)	S_{zp} (in ³)
3	2in Pipe Sch 120	1.67	1.91	0.96	0.96	0.00	1.13	1.13
6	4in Pipe Sch 120	5.58	23.29	11.64	11.64	0.00	7.24	7.24
11	10in Pipe Sch 40	11.91	321.47	160.73	160.73	0.00	39.38	39.38

2	251.01	246.00	27.16	27.16	75.30	75.30
3	151.65	149.42	20.17	14.14	54.12	28.95
4	151.65	136.71	20.17	14.14	54.12	28.95
5	151.65	145.68	20.17	14.14	54.12	28.95
6	151.65	149.42	20.17	14.14	54.12	28.95
7	151.65	145.68	20.17	14.14	54.12	28.95
8	159.30	86.08	46.90	6.46	56.26	44.91
9	75.10	55.95	4.25	4.25	22.53	22.53
10	151.65	136.71	20.17	14.14	54.12	28.95
11	159.30	86.08	46.90	6.46	56.26	44.91
12	251.01	246.00	27.16	27.16	75.30	75.30
13	159.30	139.89	46.90	6.46	56.26	44.91
14	159.30	139.89	46.90	6.46	56.26	44.91
15	159.30	86.08	46.90	6.46	56.26	44.91
16	159.30	86.08	46.90	6.46	56.26	44.91
17	159.30	116.35	44.63	6.46	56.26	44.91
18	159.30	139.89	46.90	6.46	56.26	44.91
19	159.30	116.35	44.20	6.46	56.26	44.91
20	159.30	139.89	46.90	6.46	56.26	44.91

Design Ratio

Member ID	P	M _z	M _y	V _y	V _z	(P,M _z ,M _y)	Worst LC	KL/r	δ	Status
1	0.019	0.227	0.000	0.026	0.000	0.236	#13	0.256	Not Required	Pass
2	0.005	0.234	0.160	0.055	0.028	0.396	#13	0.055	Not Required	Pass
3	0.007	0.407	0.046	0.041	0.007	0.425	#13	0.071	Not Required	Pass
4	0.007	0.370	0.178	0.037	0.037	0.431	#21	0.126	Not Required	Pass
5	0.007	0.252	0.184	0.040	0.049	0.280	#13	0.117	Not Required	Pass
6	0.007	0.407	0.046	0.041	0.007	0.425	#13	0.071	Not Required	Pass
7	0.007	0.252	0.184	0.040	0.049	0.281	#13	0.117	Not Required	Pass
8	0.000	0.078	0.293	0.022	0.014	0.361	#21	Not Required	Not Required	Pass
9	0.029	0.030	0.037	0.001	0.000	0.074	#13	0.317	Not Required	Pass
10	0.007	0.370	0.178	0.037	0.037	0.431	#21	0.126	Not Required	Pass
11	0.000	0.085	0.293	0.024	0.014	0.365	#21	Not Required	Not Required	Pass
12	0.005	0.234	0.160	0.055	0.028	0.396	#13	0.055	Not Required	Pass
13	0.000	0.142	0.489	0.031	0.018	0.609	#21	Not Required	Not Required	Pass
14	0.000	0.129	0.489	0.028	0.018	0.602	#21	Not Required	Not Required	Pass
15	0.000	0.085	0.293	0.024	0.014	0.365	#21	Not Required	Not Required	Pass
16	0.000	0.078	0.293	0.022	0.014	0.361	#21	Not Required	Not Required	Pass
17	0.009	0.156	0.085	0.008	0.005	0.220	#21	0.204	Not Required	Pass
18	0.000	0.142	0.489	0.031	0.018	0.609	#21	Not Required	Not Required	Pass
19	0.009	0.145	0.100	0.007	0.005	0.231	#21	0.306	Not Required	Pass
20	0.000	0.129	0.489	0.028	0.018	0.602	#21	Not Required	Not Required	Pass

Definitions

Φ_t	Safety factor for tensile
Φ_c	Safety factor for compression
Φ_b	Safety factor for flexure
Φ_v	Safety factor for shear
E	Modulus of elasticity
F _y	Specified minimum yield stress
F _u	Specified minimum tensile strength
A	Cross-sectional area
J	Torsional constant
I _y	Moment of inertia about the Y axis

I_{yp}	Moment of inertia about the Y axes
I_{zp}	Moment of inertia about the Z axes
I_w	Warping constant
S_{yp}	Plastic section modulus about the Y axis
S_{zp}	Plastic section modulus about the Z axis
KL	Effective length
C_b	Buckling modification factor (from all load combinations)
L_b	Length between braced points
LST	Limited slenderness for tension
LSC	Limited slenderness for compression
LD	Limited deflection
P_n	Nominal axial strength (tension/compression)
M_n	Nominal flexural strength (about Z/Y axis)
V_n	Nominal shear strength (along Z/Y axis)
P	Design ratio in case of axial force
M_z	Design ratio in case of bending about Z axis
M_y	Design ratio in case of bending about Y axis
V_y	Design ratio in case of shear along Y axis
V_z	Design ratio in case of shear along Z axis
(P, M_z, M_y)	Design ratio in case of axial force and bending action
KL/r	Design ratio in case of section slenderness
δ	Design ratio in case of member deflection
OK	Capacity is provided
NG	Capacity is not provided

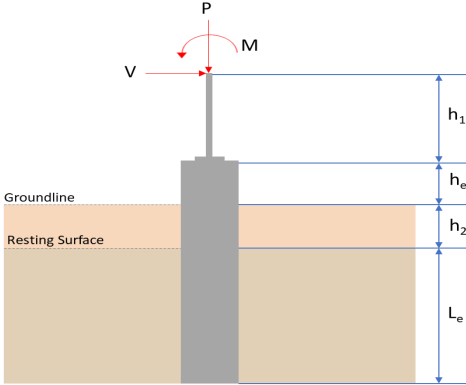
REFERENCES	CALCULATIONS	RESULTS																										
	<p>SkyCiv Foundation Design Pile Foundation</p> <p>Design Information : Design code : IBC 2021 (International Building Code) Unit System : Imperial</p>																											
	<p>Pile Input</p>  <p>Geometry Pile shape: round $D = 36$ in - Pile diameter $L = 7.75$ ft - Total pile length $h_1 = 0$ ft - Lateral load height from the top of the pile, $h_2 = 0$ ft - Depth to resisting surface $h_e = 0$ ft - Length of pile above the ground</p> <p>Tabulation of Soil Parameters</p> <table border="1" data-bbox="416 1079 1193 1171"> <thead> <tr> <th>Layer</th> <th>Label</th> <th>Allowable Bearing Pressure (q_a) (psf)</th> <th>Allowable Lateral Pressure (R) (psf/ft)</th> </tr> </thead> <tbody> <tr> <td>1</td> <td>Sand, silty sand, clayey sand, silty gravel & clayey gravel</td> <td>2000.000</td> <td>150.000</td> </tr> </tbody> </table> <p>Tabulation of Loads</p> <table border="1" data-bbox="676 1265 935 1435"> <thead> <tr> <th>Load Component</th> <th>ASD</th> <th>LRFD</th> </tr> </thead> <tbody> <tr> <td>P (kip)</td> <td>5.934</td> <td>8.613</td> </tr> <tr> <td>V_x (kip)</td> <td>-2.554</td> <td>-4.257</td> </tr> <tr> <td>V_z (kip)</td> <td>0.000</td> <td>0.000</td> </tr> <tr> <td>M_x (kipft)</td> <td>0.000</td> <td>0.000</td> </tr> <tr> <td>M_z (kipft)</td> <td>20.035</td> <td>33.495</td> </tr> </tbody> </table> <p>Material Properties $f'_{ck} = 3$ ksi - Concrete strength,</p>	Layer	Label	Allowable Bearing Pressure (q_a) (psf)	Allowable Lateral Pressure (R) (psf/ft)	1	Sand, silty sand, clayey sand, silty gravel & clayey gravel	2000.000	150.000	Load Component	ASD	LRFD	P (kip)	5.934	8.613	V_x (kip)	-2.554	-4.257	V_z (kip)	0.000	0.000	M_x (kipft)	0.000	0.000	M_z (kipft)	20.035	33.495	
Layer	Label	Allowable Bearing Pressure (q_a) (psf)	Allowable Lateral Pressure (R) (psf/ft)																									
1	Sand, silty sand, clayey sand, silty gravel & clayey gravel	2000.000	150.000																									
Load Component	ASD	LRFD																										
P (kip)	5.934	8.613																										
V_x (kip)	-2.554	-4.257																										
V_z (kip)	0.000	0.000																										
M_x (kipft)	0.000	0.000																										
M_z (kipft)	20.035	33.495																										
	<p>Required depth to resist lateral loads (ASD) H - Point of application of the lateral load</p> $H = h_1 + h_2 + h_e$ $H = (0 \text{ ft}) + (0 \text{ ft}) + (0 \text{ ft})$ $H = 0 \text{ ft}$ <p>Considering x-direction: H_o - Lateral force per length of pile,</p> $H_o = \frac{V_x}{D}$ $H_o = \frac{(-2.554 \text{ kip})}{(36 \text{ in})}$ $H_o = -0.85133 \text{ kip/ft}$ <p>M_o - Moment per length of pile,</p> $M_o = \frac{M_z + (V_x H)}{D}$																											

	$M_o = \frac{(20.035 \text{ kipft}) + ((-2.554 \text{ kip}) \times (0 \text{ ft}))}{(36 \text{ in})}$ $M_o = 6.6783 \text{ kipft/ft}$ <p>Required depth of embedment in earth:</p> $L_x^3 - \left(14.14 \times \frac{H_o \times L_x}{R}\right) - \left(18.85 \times \frac{M_o}{R}\right) = 0$ <p>Solving the cubic equation: $L_{e,x} = 6.7037 \text{ ft}$ - Required depth in x-direction,</p> <p>Considering z-direction: $L_{e,z} = 0 \text{ ft}$ - Required depth in z-direction,</p> <p>Minimum embedded depth required: $L_{e,req}$ - Depth of pile required,</p> $L_{e,req} = \text{MAX}[L_{e,x}, L_{e,z}]$ $L_{e,req} = \text{MAX}[(6.7037 \text{ ft}), (0 \text{ ft})]$ $L_{e,req} = 6.704 \text{ ft}$ <p>L_e - Actual embedded length of pile,</p> $L_e = L - h_c - h_2$ $L_e = (7.75 \text{ ft}) - (0 \text{ ft}) - (0 \text{ ft})$ $L_e = 7.75 \text{ ft}$ <p>Ratio - Embedded depth</p> $\text{Ratio} = \frac{L_{e,req}}{L_e}$ $\text{Ratio} = \frac{(6.704 \text{ ft})}{(7.75 \text{ ft})}$ $\text{Ratio} = 0.86503$	<p>Status: PASS Ratio: 0.870</p>
	<p>End-bearing Capacity (ASD)</p> <p>A - Pile cross-section area</p> $A = \pi \left(\frac{D}{2}\right)^2$ $A = \pi \times \left(\frac{(36 \text{ in})}{2}\right)^2$ $A = 7.0686 \text{ ft}^2$ <p>q - End-bearing pressure</p> $q = \frac{P_c}{A}$ $q = \frac{(5.934 \text{ kip})}{(7.0686 \text{ ft}^2)}$ $q = 0.83949 \text{ kip/ft}^2$ <p>Check bearing capacity ratio:</p> <p>Ratio - Capacity</p> $\text{Ratio} = \frac{q}{q_a}$ $\text{Ratio} = \frac{(0.83949 \text{ kip/ft}^2)}{(2000 \text{ psf})}$ $\text{Ratio} = 0.41974$	<p>Status: PASS Ratio: 0.420</p>
Czerniak	<p>Lateral Soil Pressure (ASD):</p> <p>L/D - Length to least lateral dimension ratio,</p> $L/D = \frac{L}{D}$ $L/D = \frac{(7.75 \text{ ft})}{(36 \text{ in})}$	

$$L/D = 2.5833$$

Since $L/D \leq 10$,

Pile is short.

Considering x-direction:

$H_o = -0.85133$ kip/ft - Lateral force per length of pile,

$M_o = 6.6783$ kipft/ft - Overturning moment per length of pile,

a - Distance from resting surface to pivot point,

$$a = \frac{(4 M_o L_e) + (3 H_o L_e^2)}{(6 M_o) + (4 H_o L_e)}$$

$$a = \frac{(4 \times (6.6783 \text{ kipft/ft}) \times (7.75 \text{ ft})) + (3 \times (-0.85133 \text{ kip/ft}) \times (7.75 \text{ ft})^2)}{(6 \times (6.6783 \text{ kipft/ft})) + (4 \times (-0.85133 \text{ kip/ft}) \times (7.75 \text{ ft}))}$$

$$a = 5.4231 \text{ ft}$$

p - Earth pressure against the pile at distance $a/2$ from resting surface,

$$p = \frac{1.178 [(4 M_o) + (3 H_o L_e)]^2}{L_e^2 [(3 M_o) + (2 H_o L_e)]}$$

$$p = \frac{1.178 \times [(4 \times (6.6783 \text{ kipft/ft})) + (3 \times (-0.85133 \text{ kip/ft}) \times (7.75 \text{ ft}))]^2}{(7.75 \text{ ft})^2 \times [(3 \times (6.6783 \text{ kipft/ft})) + (2 \times (-0.85133 \text{ kip/ft}) \times (7.75 \text{ ft}))]}$$

$$p = 0.13732 \text{ kip/ft}^2$$

s - Earth pressure against the pile at distance L_e ,

$$s = \frac{9.425 [(2 M_o) + (H_o L_e)]}{L_e^2}$$

$$s = \frac{9.425 \times [(2 \times (6.6783 \text{ kipft/ft})) + ((-0.85133 \text{ kip/ft}) \times (7.75 \text{ ft}))]}{(7.75 \text{ ft})^2}$$

$$s = 1.0606 \text{ kip/ft}^2$$

Check lateral soil pressure capacity:

p_a - Allowable lateral soil pressure at depth $a/2$,

$$p_a = R \frac{a}{2}$$

$$p_a = (150 \text{ psf/ft}) \times \frac{(5.4231 \text{ ft})}{2}$$

$$p_a = 0.40673 \text{ kip/ft}^2$$

Ratio - Lateral soil capacity

$$\text{Ratio} = \frac{p}{p_a}$$

$$\text{Ratio} = \frac{(0.13732 \text{ kip/ft}^2)}{(0.40673 \text{ kip/ft}^2)}$$

$$\text{Ratio} = 0.3376$$

p_s - Allowable lateral soil pressure at depth L_e ,

$$p_s = R L_e$$

$$p_s = (150 \text{ psf/ft}) \times (7.75 \text{ ft})$$

$$p_s = 1.1625 \text{ kip/ft}^2$$

Ratio - Lateral soil capacity

$$\text{Ratio} = \frac{s}{p_s}$$

$$\text{Ratio} = \frac{(1.0606 \text{ kip/ft}^2)}{(1.1625 \text{ kip/ft}^2)}$$

$$\text{Ratio} = 0.91234$$

Status: **PASS**
Ratio: **0.340**

Status: **PASS**
Ratio: **0.910**

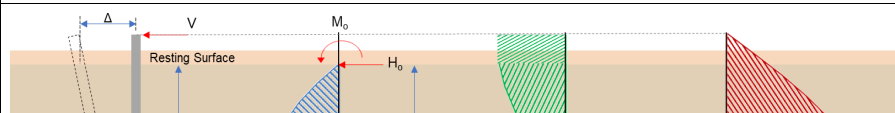

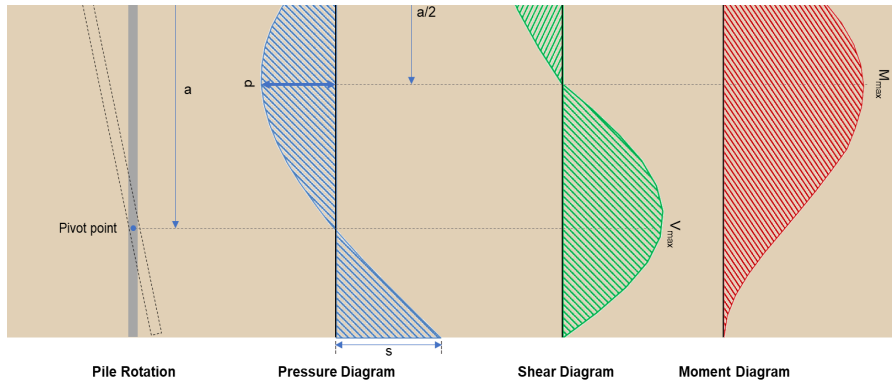

Shear force and Bending moment (x-direction, LRFD)

H_o - Lateral force per length of pile,

$$H_o = \frac{V_x}{D}$$

$$H_o = \frac{(-4.257 \text{ kip})}{(36 \text{ in})}$$

$$H_o = -1.419 \text{ kip/ft}$$

M_o - Moment per length of pile,

$$M_o = \frac{M_x + (V_x H)}{D}$$

$$M_o = \frac{(33.495 \text{ kipft}) + ((-4.257 \text{ kip}) \times (0 \text{ ft}))}{(36 \text{ in})}$$

$$M_o = 11.165 \text{ kipft/ft}$$

E - Distance from lateral load to resisting surface,

$$E = \frac{M_o}{H_o}$$

$$E = \frac{(11.165 \text{ kipft/ft})}{(-1.419 \text{ kip/ft})}$$

$$E = 7.8682 \text{ ft}$$

a - Distance from resting surface to pivot point,

$$a = \frac{(4 M_o L_c) + (3 H_o L_c^2)}{(6 M_o) + (4 H_o L_c)}$$

$$a = \frac{(4 \times (11.165 \text{ kipft/ft}) \times (7.75 \text{ ft})) + (3 \times (-1.419 \text{ kip/ft}) \times (7.75 \text{ ft})^2)}{(6 \times (11.165 \text{ kipft/ft})) + (4 \times (-1.419 \text{ kip/ft}) \times (7.75 \text{ ft}))}$$

$$a = 5.4227 \text{ ft}$$

V_{max} - Max shear force located at depth a ,

$$V_{max} = (H_o D) \left[1 - \left[3 \left(\frac{4 E}{L_c} + 3 \right) \left(\frac{a}{L_c} \right)^2 + 4 \left(\frac{3 E}{L_c} + 2 \right) \left(\frac{a}{L_c} \right)^3 \right] \right]$$

$$V_{max} = ((-1.419 \text{ kip/ft}) \times (36 \text{ in})) \times \left[1 - \left[3 \times \left(\frac{4 \times (7.8682 \text{ ft})}{(7.75 \text{ ft})} + 3 \right) \times \left(\frac{(5.4227 \text{ ft})}{(7.75 \text{ ft})} \right)^2 + 4 \times \left(\frac{3 \times (7.8682 \text{ ft})}{(7.75 \text{ ft})} + 2 \right) \times \left(\frac{(5.4227 \text{ ft})}{(7.75 \text{ ft})} \right)^3 \right] \right]$$

$$V_{max} = 10.459 \text{ kip}$$

M_{max} - Max bending moment located at depth $a/2$,

$$M_{max} = (H_o D L_c) \left[\left(\frac{E}{L_c} + \frac{a}{2 L_c} \right) - \left[\left(\frac{4 E}{L_c} + 3 \right) \left(\frac{a}{2 L_c} \right)^3 + \left(\frac{3 E}{L_c} + 2 \right) \left(\frac{a}{2 L_c} \right)^4 \right] \right]$$

$$M_{max} = ((-1.419 \text{ kip/ft}) \times (36 \text{ in}) \times (7.75 \text{ ft})) \times \left[\left(\frac{(7.8682 \text{ ft})}{(7.75 \text{ ft})} + \frac{(5.4227 \text{ ft})}{2 \times (7.75 \text{ ft})} \right) - \left[\left(\frac{4 \times (7.8682 \text{ ft})}{(7.75 \text{ ft})} + 3 \right) \times \left(\frac{(5.4227 \text{ ft})}{2 \times (7.75 \text{ ft})} \right)^3 + \left[\left(\frac{3 \times (7.8682 \text{ ft})}{(7.75 \text{ ft})} + 2 \right) \times \left(\frac{(5.4227 \text{ ft})}{2 \times (7.75 \text{ ft})} \right)^4 \right] \right] \right]$$

$$M_{max} = 37.556 \text{ kipft}$$

Minimum Reinforcement Check (LRFD)

Parameters:

$f'_{ck} = 3 \text{ ksi}$ - Concrete strength,
 $f_{yk} = 60 \text{ ksi}$ - Longitudinal reinforcement strength,
 $\phi = 0.65$ - Reduction factor for axial strength,
 $\alpha = 0.85$ - Alpha factor for axial strength,
 $A_g = 1017.9 \text{ in}^2$ - Gross area of concrete,

Table 22.4.2.1

Longitudinal reinforcement:

Required reinforcement due to axial load, $A_{st,required}$

22.4.2.2, 10.6.1.1

$A_{st,required}$

$$A_{st,required} = \text{Min} \left[\frac{\frac{P}{\phi \alpha} - (0.85 f'_{ck} A_g)}{f_{yk} - (0.85 f'_{ck})}, (0.08 A_g) \right]$$

$$A_{st,required} = \text{Min} \left[\frac{\frac{(8.613 \text{ kip})}{(0.65) \times (0.85)} - (0.85 \times (3 \text{ ksi}) \times (1017.9 \text{ in}^2))}{(60 \text{ ksi}) - (0.85 \times (3 \text{ ksi}))}, (0.08 \times (1017.9 \text{ in}^2)) \right]$$

$$A_{st,required} = -44.909 \text{ in}^2$$

A_{min} - Governing minimum reinforcement area,

$$A_{min} = \text{Max} [A_{st,required}, (0.0018 A_g)]$$

$$A_{min} = \text{Max} [(-44.909 \text{ in}^2), (0.0018 \times (1017.9 \text{ in}^2))]$$

$$A_{min} = 1.8322 \text{ in}^2$$

n_{rebar} - Required number of reinforcement,

$$n_{rebar} = \frac{A_{min}}{A_{rebar}}$$

$$n_{rebar} = \frac{(1.8322 \text{ in}^2)}{(0.3068 \text{ in}^2)}$$

$$n_{rebar} = 6$$

A_{st} - Actual total reinforcement area,

$$A_{st} = n_{rebar} \frac{\pi d_{bar}^2}{4}$$

$$A_{st} = (6) \times \frac{\pi \times (0.625 \text{ in})^2}{4}$$

$$A_{st} = 1.8408 \text{ in}^2$$

Ratio - Capacity

$$\text{Ratio} = \frac{A_{min}}{A_{st}}$$

$$\text{Ratio} = \frac{(1.8322 \text{ in}^2)}{(1.8408 \text{ in}^2)}$$

$$\text{Ratio} = 0.99533$$

25.2.3

s_{rebar} - Minimum spacing of reinforcement,

$$s_{rebar} = \text{Max} [1.5, (1.5 d_{bar})]$$

$$s_{rebar} = \text{Max} [1.5, (1.5 \times (0.625 \text{ in}))]$$

$$s_{rebar} = 1.5 \text{ in}$$

Ties:

25.7.2.2

Since longitudinal reinforcement is \leq No. 10Ø: Use #3(0.375 in)

25.7.2.1

s_{ties} - Maximum center-to-center spacing of ties,

$$s_{ties} = \text{Min} [(16 d_{bar}), (48 d_{ties}), D]$$

$$s_{ties} = \text{Min} [(16 \times (0.625 \text{ in})), (48 \times (0.375 \text{ in})), (36 \text{ in})]$$

$$s_{ties} = 10 \text{ in}$$

Summary:

Status: **PASS**
Ratio: **1.000**

Main reinforcement: **6 - #5 (0.625 in)**
Ties: **#3(0.375 in) - 10 in**

Axial Compression Strength (ACI 318-19, LRFD)

22.4.2.2 ϕP_N - Allowable axial compressive strength

$$\phi P_N = \phi 0.85 [(0.85 f'_{ck} [A_g - A_{st}]) + (f_{yk} A_{st})]$$

$$\phi P_N = (0.65) \times 0.85 \times [(0.85 \times (3 \text{ ksi}) \times [(1017.9 \text{ in}^2) - (1.8408 \text{ in}^2)]) + ((60 \text{ ksi}) \times (1.8408 \text{ in}^2))]$$

$$\phi P_N = 1492.5 \text{ kip}$$

Ratio - Capacity

$$\text{Ratio} = \frac{P}{\phi P_N}$$

$$\text{Ratio} = \frac{(8.613 \text{ kip})}{(1492.5 \text{ kip})}$$

$$\text{Ratio} = 0.0057709$$

Status: **PASS**
Ratio: **0.010**

Shear Strength (ACI 318-19, LRFD)

Parameters:

$b_w = 36 \text{ in}$ - Effective width,
22.5.2.2 d - Effective depth

$$d = 0.80 D$$

$$d = 0.80 \times (36 \text{ in})$$

$$d = 28.8 \text{ in}$$

22.5.5.1.3 λ_s - size effect modification factor

$$\lambda_s = \text{MIN} \left[\sqrt{\frac{2}{1 + \frac{d}{10}}}, 1 \right]$$

$$\lambda_s = \text{MIN} \left[\sqrt{\frac{2}{1 + \frac{(28.8 \text{ in})}{10}}}, 1 \right]$$

$$\lambda_s = 0.71796$$

The following variables were converted to be consistent with empirical formula $f'_{ck} = 3 \text{ ksi} \rightarrow 3000 \text{ psi}$.

22.5.5.1.1 $V_{c,max}$ - Max shear strength of concrete

$$V_{c,max} = 5 \lambda_s \sqrt{f'_{ck}} b_w d$$

$$V_{c,max} = 5 \times (0.71796) \times \sqrt{(3000 \text{ psi})} \times (36 \text{ in}) \times (28.8 \text{ in})$$

$$V_{c,max} = 203.86 \text{ kip}$$

The following variables were converted to be consistent with empirical formula $f'_{ck} = 3 \text{ ksi} \rightarrow 3000 \text{ psi}$, $P = 8.613 \text{ kip} \rightarrow 8613 \text{ lbf}$.

22.5.5.1.1(a) $V_{c,a}$ - Shear strength of concrete (a)

$$V_{c,a} = \left[2 \lambda_s \sqrt{f'_{ck}} + \frac{P}{6 A_g} \right] b_w d$$

$$V_{c,a} = \left[2 \times (0.71796) \times \sqrt{(3000 \text{ psi})} + \frac{(8613 \text{ lbf})}{6 \times (1017.9 \text{ in}^2)} \right] \times (36 \text{ in}) \times (28.8 \text{ in})$$

$$V_{c,a} = 83.005 \text{ kip}$$

The following variables were converted to be consistent with empirical formula $f'_{ck} = 3 \text{ ksi} \rightarrow 3000 \text{ psi}$.

22.5.5.1.2 $V_{c,b}$ - Shear strength of concrete (b)

$$V_{c,b} = \left[2 \lambda_s \sqrt{f'_{ck}} + (0.05 f'_{ck}) \right] b_w d$$

$$V_{c,b} = \left[2 \times (0.71796) \times \sqrt{(3000 \text{ psi})} + (0.05 \times (3000 \text{ psi})) \right] \times (36 \text{ in}) \times (28.8 \text{ in})$$

$$V_{c,b} = 237.06 \text{ kip}$$

V_c - Governing shear strength of concrete

$$V_c = \text{Min} [V_{c,max}, V_{c,a}, V_{c,b}]$$

$$V_c = \text{Min} [(203.86 \text{ kip}), (83.005 \text{ kip}), (237.06 \text{ kip})]$$

<p>22.5.1.2</p> <p>22.5.8.5.3</p> <p>22.5.1.1</p>	<p style="text-align: center;">$V_c = 83.005 \text{ kip}$</p> <p>The following variables were converted to be consistent with empirical formula $f'_{ck} = 3 \text{ ksi} \rightarrow 3000 \text{ psi}$.</p> <p>$V_{s,a}$ - Shear strength of steel (a)</p> $V_{s,a} = 8 \sqrt{f'_{ck}} b_w d$ $V_{s,a} = 8 \times \sqrt{(3000 \text{ psi})} \times (36 \text{ in}) \times (28.8 \text{ in})$ $V_{s,a} = 454.3 \text{ kip}$ <p>A_v - Ties rebar area,</p> $A_v = \frac{\pi d_{ties}^2}{4}$ $A_v = \frac{\pi \times (0.375 \text{ in})^2}{4}$ $A_v = 0.11045 \text{ in}^2$ <p>$V_{s,b}$ - Shear strength of steel (b)</p> $V_{s,b} = \frac{2 A_v f_{yw} d}{s_{ties}}$ $V_{s,b} = \frac{2 \times (0.11045 \text{ in}^2) \times (60 \text{ ksi}) \times (28.8 \text{ in})}{(10 \text{ in})}$ $V_{s,b} = 38.17 \text{ kip}$ <p>V_s - Governing shear strength of steel</p> $V_s = \text{MIN}[V_{s,a}, V_{s,b}]$ $V_s = \text{MIN}[(454.3 \text{ kip}), (38.17 \text{ kip})]$ $V_s = 38.17 \text{ kip}$ <p>ϕV_n - Allowable shear strength</p> $\phi V_n = \phi (V_c + V_s)$ $\phi V_n = (0.65) \times ((83.005 \text{ kip}) + (38.17 \text{ kip}))$ $\phi V_n = 78.764 \text{ kip}$ <p>Considering x-direction:</p> <p>$V_{max} = 10.459 \text{ kip}$ - Maximum shear force in the x-direction, <i>Ratio</i> - Capacity</p> $\text{Ratio} = \frac{V_{max}}{\phi V_n}$ $\text{Ratio} = \frac{(10.459 \text{ kip})}{(78.764 \text{ kip})}$ $\text{Ratio} = 0.13279$	<p>Status: PASS Ratio: 0.130</p>
<p>14.5.2.1b</p>	<p>Flexural Strength (ACI 318-19, LFRD)</p> <p>S_m - Section modulus</p> $S_m = \frac{\pi D^3}{32}$ $S_m = \frac{\pi \times (36 \text{ in})^3}{32}$ $S_m = 4580.4 \text{ in}^3$ <p>$\lambda = 1$ - Concrete modification factor (Normal concrete), Allowable flexural strength: M_n shall be the lesser of:</p> <p>$\phi M_{n,1}$</p> $\phi M_{n,1} = \phi \times 5 \times \lambda \times \sqrt{f'_c} \times S_m$ $\phi M_{n,1} = 0.65 \times 5 \times 1 \times \sqrt{(3 \text{ ksi})} \times 4580.442 \text{ in}^3$ $\phi M_{n,1} = 67.947 \text{ kipft}$ <p>$\phi M_{n,2}$</p>	

$$\phi M_{n,2} = \phi 0.85 f'_{ck} S_m$$

$$\phi M_{n,2} = (0.65) \times 0.85 \times (3 \text{ ksi}) \times (4580.4 \text{ in}^3)$$

$$\phi M_{n,2} = 632.67 \text{ kipft}$$

Therefore,

ϕM_n - Allowable flexural strength,

$$\phi M_n = \text{MIN}[\phi M_{n,1}, \phi M_{n,2}]$$

$$\phi M_n = \text{MIN}[(67.947 \text{ kipft}), (632.67 \text{ kipft})]$$

$$\phi M_n = 67.947 \text{ kipft}$$

Considering x-direction:

$M_{max} = 37.556 \text{ kipft}$ - Maximum moment in the x-direction,

Ratio - Capacity

$$\text{Ratio} = \frac{M_{max}}{\phi M_n}$$

$$\text{Ratio} = \frac{(37.556 \text{ kipft})}{(67.947 \text{ kipft})}$$

$$\text{Ratio} = 0.55272$$

Status: **PASS**
Ratio: **0.550**