

Project Details



Project Name: Tan Ngo 2nd Property

Date: Wed Jul 31 2024

Location: 326 Roy Smith Rd, Central City, CO 80427, USA

Number of Modules: 8

Unique ID: 1P-0-10TOP-XD-45-L-4Hx2W-56CJ

Number of Poles: 1

Dealer: _____

Date Sold: _____

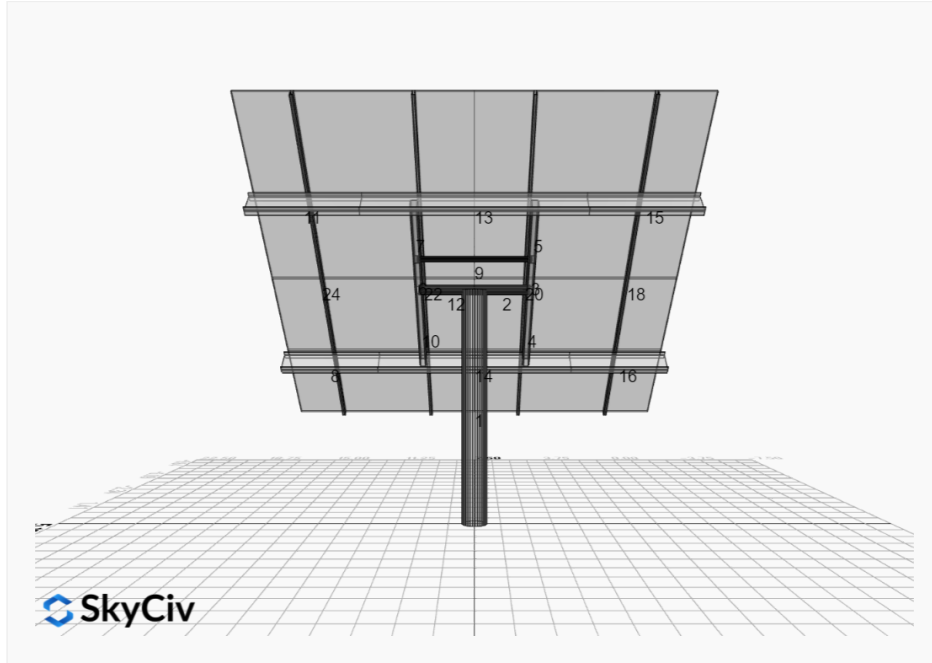

Array Dimensions N/S	15.03 ft
Array Dimensions E/W	14.97 ft
Winter Tilt Angle	46
Front Edge Clearance	3 ft

MT Solar Bill of Materials (1P-0-10TOP-XD-45-L-4Hx2W-56CJ)

Part	Short Description	BOM Qty
MTS-PC-10	10IN Pole Cap Assembly	1
MTS-HF-XD	H-Frame Assembly-XD	1
MTS-XD-Wing-45	45IN XD Wing	4
MTS-CLAMP-HOOK-4PK	Hook Clamp	2

Rail Bill of Materials

Part	Qty
Rails (178in)	4
Rail Attachment	8
Module Mid Clamp	12
Module End Clamp	8
Ground Lug	2

Site Details:



Site Address: 326 Roy Smith Rd, Central City, CO 80427, USA

Array Specification

Duty Classification:	XD
Module Width:	44.60 in
Module Length:	88.80in
Number of Rows:	4
Number of Columns:	2
Total Number of Modules:	8
Winter Tilt Angle:	46
Front Edge Clearance:	3
Total Array Height at Tilt:	13.75 ft
Total Frame Length:	15.00 ft
Frame Weight:	1140 lbs
Array Dimensions N/S:	15.03 ft
Array Dimensions E/W:	14.97 ft
Rail Length:	180.40 in
Rail Spacing:	3.70 ft

Support Specifications

Pole Size:	10in Pipe Sch 40
Pole Length above Grade:	8.41 ft
Number of Poles:	1
Pole Spacing:	0

Foundation Specifications

Foundation Type:	Square
Foundation Dimensions:	48 x 48 in
Foundation Depth (below grade):	Pile 1: 6.50 ft
Foundation Volume:	3.852 y ³

Site Info

Risk Category:	I
Exposure:	C
Soil Classification:	sand
Site Location:	326 Roy Smith Rd, Central City, CO 80427, USA
Wind Speed:	175 mph
Snow Load:	75 psf

Design Disclaimer

This software should be used for preliminary designs and should not be used as a final design unless reviewed, verified and designed by a qualified structural engineer.

AutoDesigner Input

```
{ "product_type": "Beam", "designer_name": "Haston", "designer_email": "sales@co-reliableelectric.com", "designer_phone": "9706586635", "project_id": "Tan Ngo 2nd Property", "site_address": "326 Roy Smith Rd, Central City, CO 80427, USA", "module_width": 44.6, "module_length": 88.8, "number_rows": 4, "number_columns": 2, "pole_mount_section": "4_40", "core_pipe_width": 65, "core_pipe_section": "2_40", "adjuster_section": "2_40", "core_beam_height": 65, "core_beam_section": "HSS3x2x1/8", "main_pipe_section": "2_12GA", "pole_spacing": "15", "tilt_angle": 46, "ground_clearance": 3, "risk_category": "I", "exposure_category": "C", "frame_duty_override": "XD", "pole_override": "10_40", "soil_type": "sand", "customer_foundation_override": "48_Square", "foundation_type": "Square", "foundation_size": 48, "check_rails": false, "wind_speed_override": 175, "snow_load_override": 75, "direct_snow_load": false, "add_angle_brace": false }
```

Design Notes:

- AISC Deflection checks are set to L/1 due to structure design intent
- Foundation Soil Parameters used in this Autodesign are all estimates, proper geotechnical reports are required to confirm soil profiles
- Wind speeds, snow loads and other site specific results are based on ASCE 7 2016
- Steel frame design checks are based on AISC 360 2016 (LRFD)
- Foundation Design and Sizing is approximate only

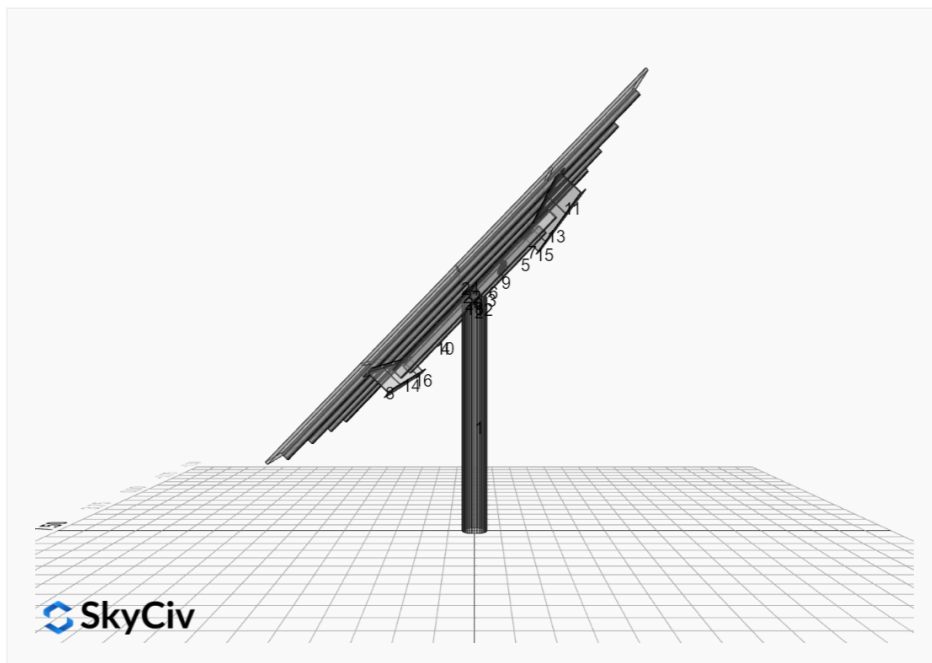
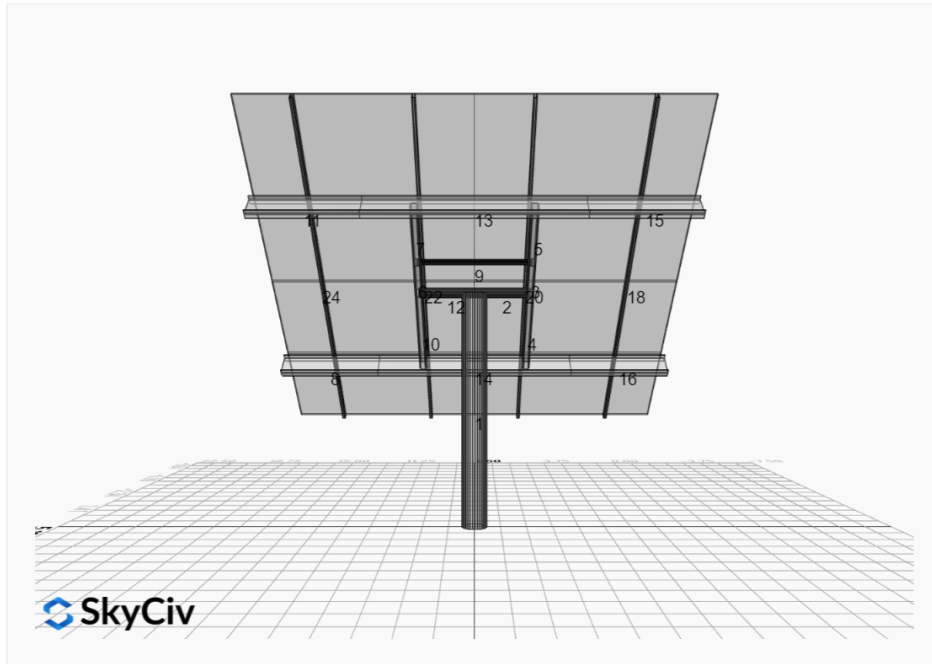

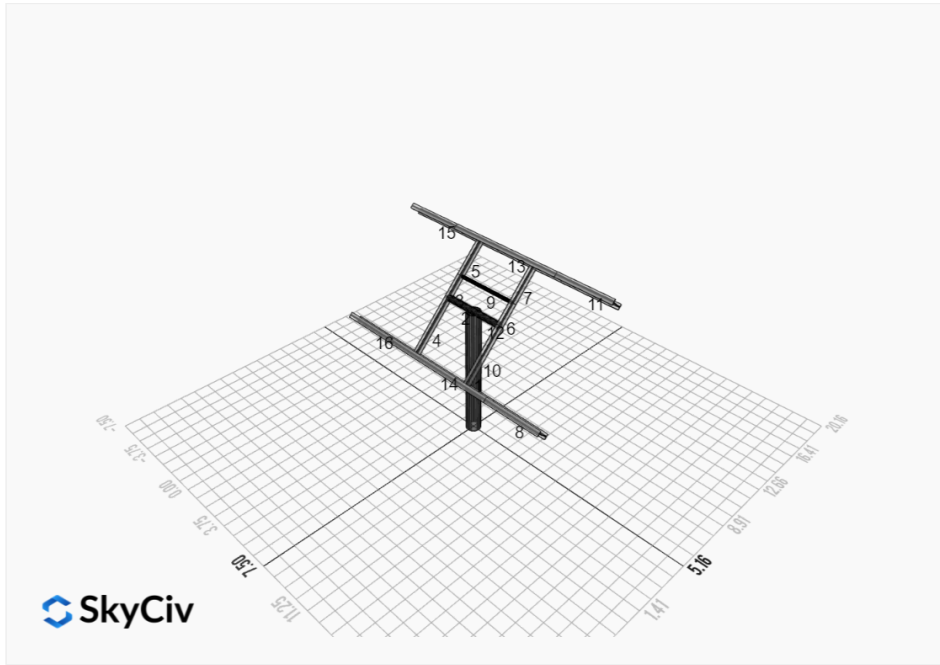
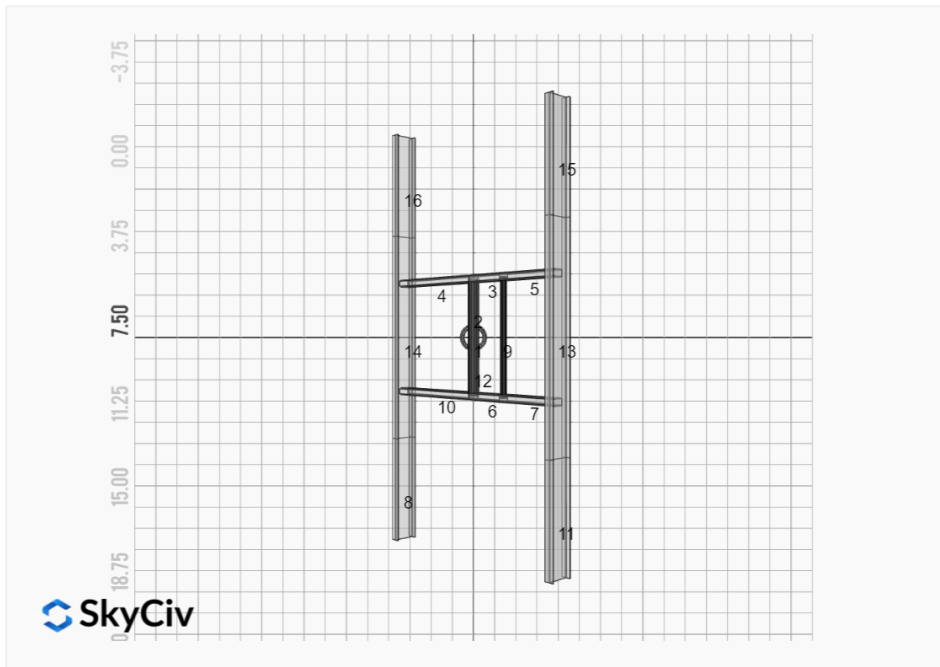

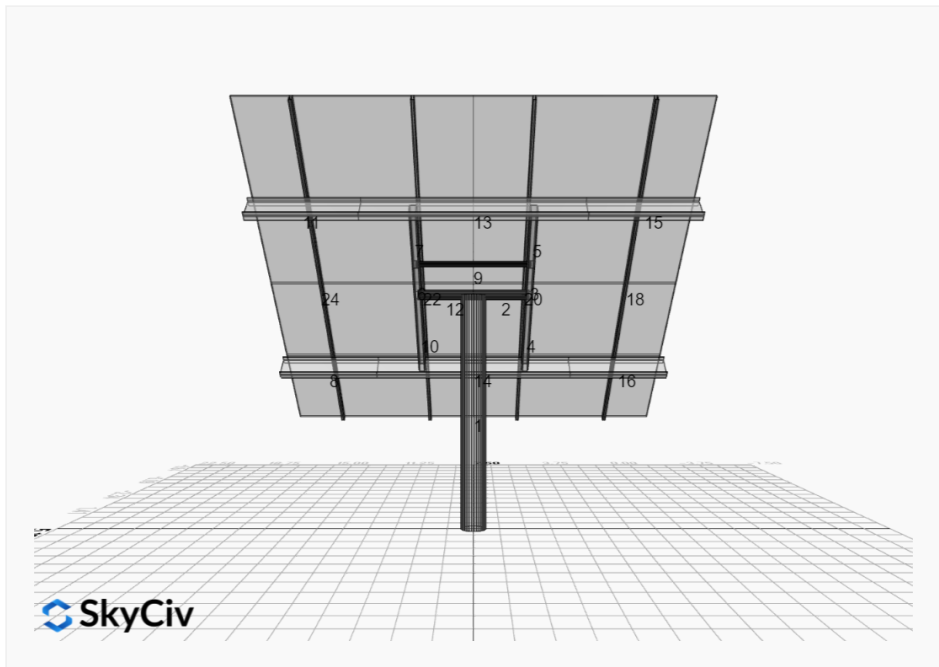

FEM Results (Envelope Worst Case for each member)

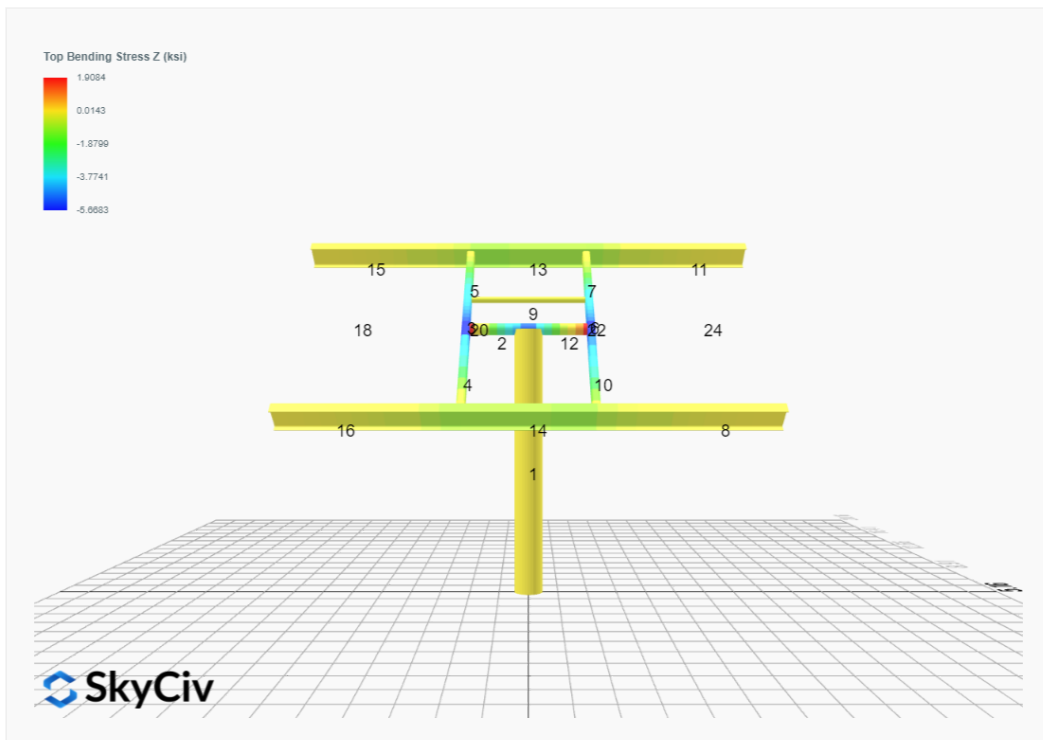
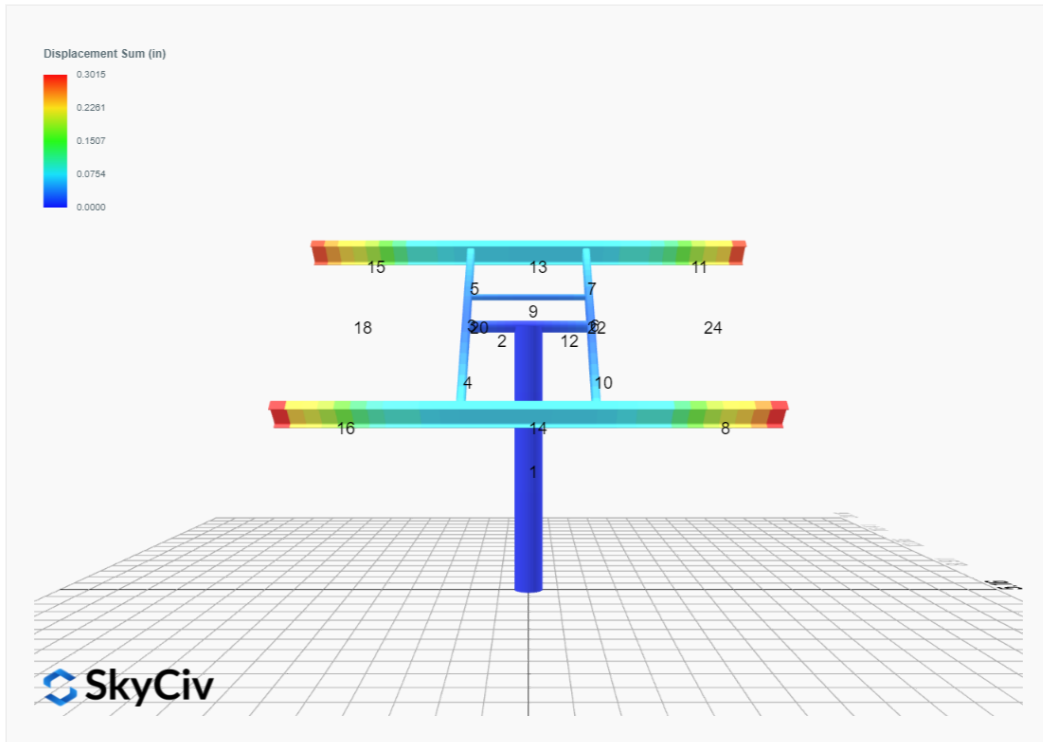

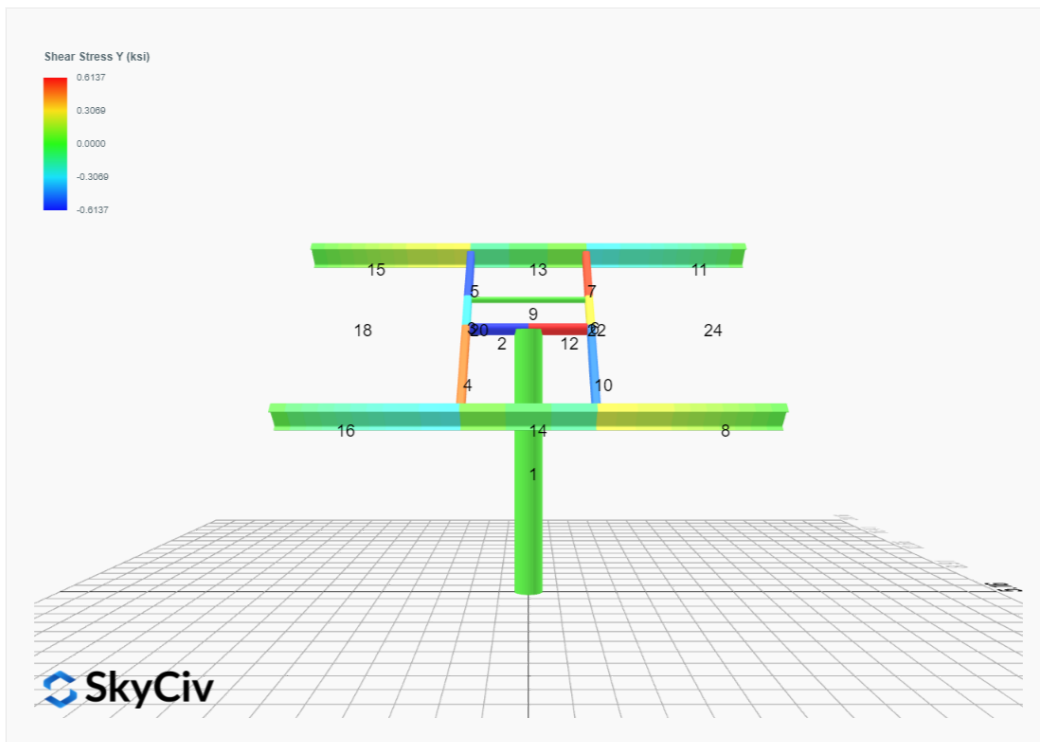
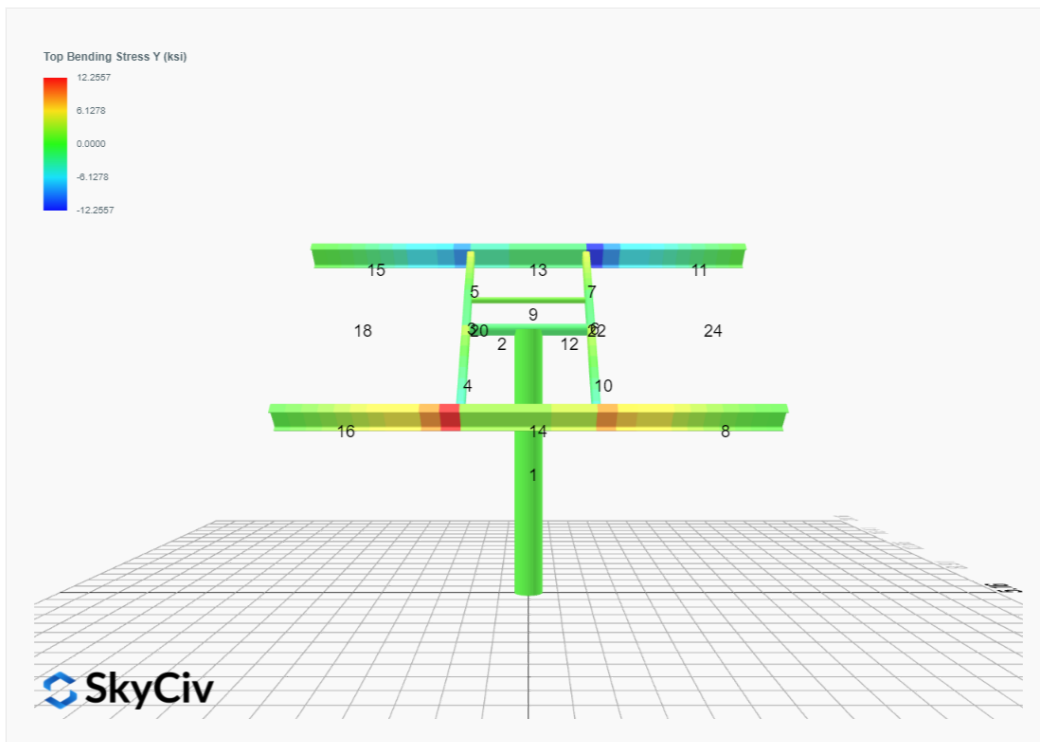

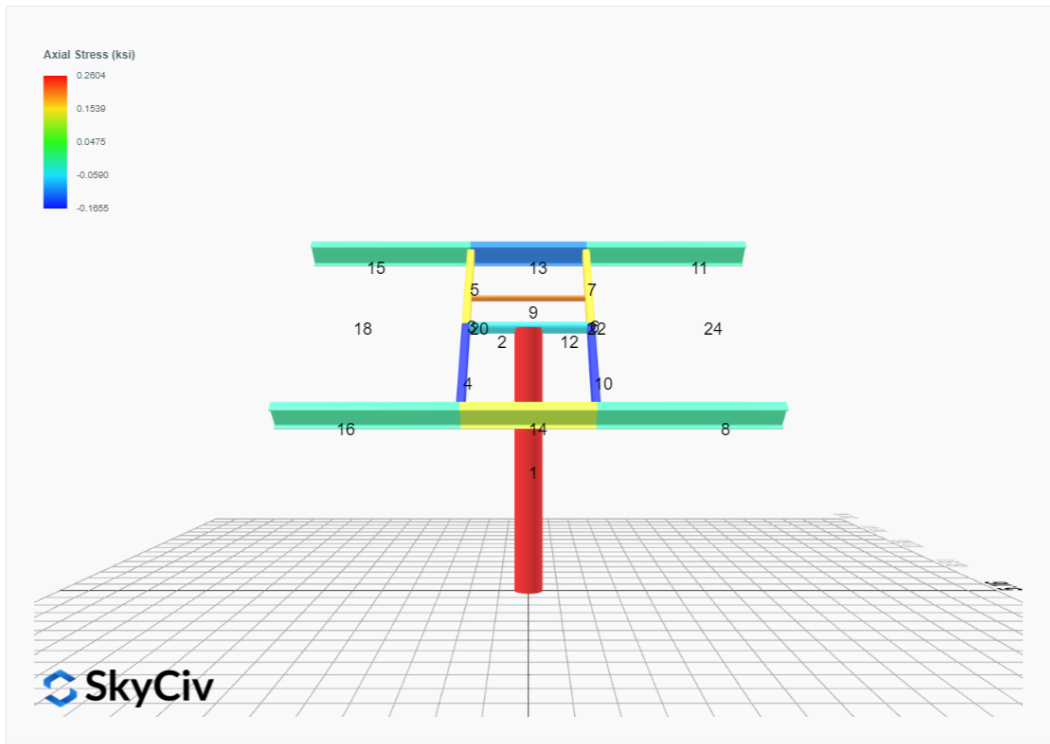

Reaction Forces for Foundation 1 (Node ID#1), (kip, kip-ft)

ASD Load Combination Results

Name	Fx	Fy	Fz	Mx	My	Mz
ULS: 1. D	0.0000	1.9927	0.0000	0.0000	-0.0000	0.0236
ULS: 2. D + L	0.0000	1.9927	0.0000	0.0000	-0.0000	0.0236
ULS: 3. D + (S or Lr or R)	0.0000	5.0932	0.0000	0.0000	-0.0000	0.0335
ULS: 3. D + (S or Lr or R)	0.0000	1.9927	0.0000	0.0000	-0.0000	0.0236
ULS: 4. D + 0.75L + 0.75(S or Lr or R)	0.0000	4.3181	0.0000	0.0000	-0.0000	0.0310
ULS: 4. D + 0.75L + 0.75(S or Lr or R)	0.0000	1.9927	0.0000	0.0000	-0.0000	0.0236
ULS: 5b. D + 0.7E	0.0000	1.9927	0.0000	0.0000	-0.0000	0.0236
ULS: 6b. D + 0.75L + 0.75(0.7)E + 0.75S	0.0000	4.3181	0.0000	0.0000	-0.0000	0.0310
ULS: 8. 0.6D + 0.7E	0.0000	1.1956	0.0000	0.0000	-0.0000	0.0142
ULS: 5a. D + 0.6W_Wind downforce Case A only	-3.7660	5.6295	0.0000	0.0000	-0.0000	31.8253
ULS: 5a. D + 0.6W_Wind downforce Case B only	0.0000	1.9927	0.0000	0.0000	-0.0000	0.0236
ULS: 5a. D + 0.6W_Wind uplift Case A only	3.7660	-1.6441	0.0000	0.0000	-0.0000	-31.4987
ULS: 5a. D + 0.6W_Wind uplift Case B only	0.0000	1.9927	0.0000	0.0000	-0.0000	0.0236
ULS: 6a. D + 0.75L + 0.75(0.6)W + 0.75(S or Lr or R)_Wind downforce Case A only	-2.8245	7.0457	0.0000	0.0000	-0.0000	23.8823
ULS: 6a. D + 0.75L + 0.75(0.6)W + 0.75(S or Lr or R)_Wind downforce Case B only	0.0000	4.3181	0.0000	0.0000	-0.0000	0.0310
ULS: 6a. D + 0.75L + 0.75(0.6)W + 0.75(S or Lr or R)_Wind uplift Case A only	2.8245	1.5905	0.0000	0.0000	-0.0000	-23.6108
ULS: 6a. D + 0.75L + 0.75(0.6)W + 0.75(S or Lr or R)_Wind uplift Case B only	0.0000	4.3181	0.0000	0.0000	-0.0000	0.0310
ULS: 6a. D + 0.75L + 0.75(0.6)W + 0.75(S or Lr or R)_Wind downforce Case A only	-2.8245	4.7203	0.0000	0.0000	-0.0000	23.8749
ULS: 6a. D + 0.75L + 0.75(0.6)W + 0.75(S or Lr or R)_Wind downforce Case B only	0.0000	1.9927	0.0000	0.0000	-0.0000	0.0236
ULS: 6a. D + 0.75L + 0.75(0.6)W + 0.75(S or Lr or R)_Wind uplift Case A only	2.8245	-0.7349	0.0000	0.0000	-0.0000	-23.6181
ULS: 6a. D + 0.75L + 0.75(0.6)W + 0.75(S or Lr or R)_Wind uplift Case B only	0.0000	1.9927	0.0000	0.0000	-0.0000	0.0236
ULS: 7. 0.6D + 0.6W_Wind downforce Case A only	-3.7660	4.8324	0.0000	0.0000	-0.0000	31.8159
ULS: 7. 0.6D + 0.6W_Wind downforce Case B only	0.0000	1.1956	0.0000	0.0000	-0.0000	0.0142
ULS: 7. 0.6D + 0.6W_Wind uplift Case A only	3.7660	-2.4412	0.0000	0.0000	-0.0000	-31.5082
ULS: 7. 0.6D + 0.6W_Wind uplift Case B only	0.0000	1.1956	0.0000	0.0000	-0.0000	0.0142

Worst Case Reactions LRFD

These calculations are taken directly from the FEA via SkyCiv and are used in the Concrete Checks of the Foundation Module.

Note: Worst case values are assumed as downforce wind load cases.

Result	Value (kip, kip-ft)
Axial	10.3828
Shear X	-6.2767
Shear Z	0.0000
Moment X	0.0000
Moment Y (Twist)	0.0000
Moment Z	53.2378

Worst Case Reactions ASD

These results are taken from the worst case values in the above table and are used in the Soil Checks in the Foundation Module.

Note: Worst case values are assumed as downforce wind load cases.

Result	Value (kip, kip-ft)
Axial	7.0457
Shear X	-3.7660
Shear Z	0.0000
Moment X	0.0000
Moment Y (Twist)	0.0000
Moment Z	31.8253

Project Details

Design Code: AISC 360-16 LRFD
 Provision: LRFD
 Country: United States
 User Name: sales@mtsolar.us
 Unit System: imperial



Design Input Information

Design Factors			
Φ_t	Φ_c	Φ_b	Φ_v
0.9	0.9	0.9	0.9

Design Materials			
ID	E (ksi)	F_y (ksi)	F_u (ksi)
1	29000	50	65

Section Dimensions							
ID	Name	d (in)	t_w (in)				
3	2in Pipe Sch 120	2.38	0.25				
6	4in Pipe Sch 120	4.50	0.44				
11	10in Pipe Sch 40	10.75	0.36				

ID	Name	d (in)	b (in)	t_w (in)	t_b (in)	r (in)	
17	HSS5x3x1/4	5.00	3.00	0.23	0.23	0.23	

ID	Name	d (in)	t_w (in)	b_t (in)	b_b (in)	t_t (in)	t_b (in)	r (in)
20	W10x12	9.87	0.19	3.96	3.96	0.21	0.21	0.30

Section Properties								
ID	Name	A (in ²)	J (in ⁴)	I_{yp} (in ⁴)	I_{zp} (in ⁴)	I_w (in ⁶)	S_{yp} (in ³)	S_{zp} (in ³)

15	159.30	55.15	46.90	6.46	56.26	44.91
16	159.30	55.15	46.90	6.46	56.26	44.91

Design Ratio

Member ID	P	M _z	M _y	V _y	V _z	(P,M _z ,M _y)	Worst LC	KL/r	δ	Status
1	0.025	0.361	0.000	0.039	0.000	0.372	#13	0.288	Not Required	Pass
2	0.002	0.291	0.221	0.066	0.042	0.512	#13	0.036	Not Required	Pass
3	0.008	0.514	0.052	0.051	0.008	0.543	#13	0.046	Not Required	Pass
4	0.008	0.512	0.130	0.051	0.028	0.558	#13	0.082	Not Required	Pass
5	0.008	0.319	0.134	0.051	0.034	0.335	#13	0.076	Not Required	Pass
6	0.008	0.514	0.052	0.051	0.008	0.543	#13	0.046	Not Required	Pass
7	0.008	0.319	0.134	0.051	0.034	0.335	#13	0.076	Not Required	Pass
8	0.000	0.055	0.173	0.024	0.013	0.218	#21	Not Required	Not Required	Pass
9	0.011	0.036	0.042	0.001	0.000	0.081	#13	0.206	Not Required	Pass
10	0.008	0.512	0.130	0.051	0.028	0.558	#13	0.082	Not Required	Pass
11	0.000	0.055	0.173	0.024	0.013	0.218	#21	Not Required	Not Required	Pass
12	0.002	0.291	0.221	0.066	0.042	0.512	#13	0.036	Not Required	Pass
13	0.006	0.190	0.372	0.036	0.019	0.514	#21	0.204	Not Required	Pass
14	0.008	0.193	0.372	0.036	0.019	0.514	#21	0.204	Not Required	Pass
15	0.000	0.055	0.173	0.024	0.013	0.218	#21	Not Required	Not Required	Pass
16	0.000	0.055	0.173	0.024	0.013	0.218	#21	Not Required	Not Required	Pass

Definitions

Φ _t	Safety factor for tensile
Φ _c	Safety factor for compression
Φ _b	Safety factor for flexure
Φ _v	Safety factor for shear
E	Modulus of elasticity
F _y	Specified minimum yield stress
F _u	Specified minimum tensile strength
A	Cross-sectional area
J	Torsional constant
I _{yp}	Moment of inertia about the Y axes
I _{zp}	Moment of inertia about the Z axes
I _w	Warping constant
S _{yp}	Plastic section modulus about the Y axis
S _{zp}	Plastic section modulus about the Z axis
KL	Effective length
C _b	Buckling modification factor (from all load combinations)
L _b	Length between braced points
LST	Limited slenderness for tension
LSC	Limited slenderness for compression
LD	Limited deflection
P _n	Nominal axial strength (tension/compression)
M _n	Nominal flexural strength (about Z/Y axis)
V _n	Nominal shear strength (along Z/Y axis)
P	Design ratio in case of axial force
M _z	Design ratio in case of bending about Z axis
M _y	Design ratio in case of bending about Y axis
V _y	Design ratio in case of shear along Y axis
V _z	Design ratio in case of shear along Z axis
(P,M _z ,M _y)	Design ratio in case of axial force and bending action
KL/r	Design ratio in case of section slenderness
δ	Design ratio in case of member deflection
OK	Capacity is provided
NG	Capacity is not provided

REFERENCES	CALCULATIONS	RESULTS
------------	--------------	---------

SkyCiv Foundation Design

Pile Foundation

Design Information :

Design code : IBC 2021 (International Building Code)
Unit System : Imperial

Pile Input

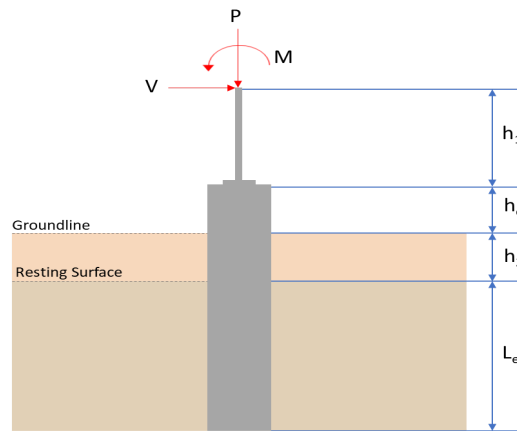

Geometry

Pile shape: rectangular

$b = 48$ in - Pile width

$D = 48$ in - Pile depth

$L = 6.5$ ft - Total pile length

$h_1 = 0$ ft - Lateral load height from the top of the pile,

$h_2 = 0$ ft - Depth to resisting surface

$h_e = 0$ ft - Length of pile above the ground

Tabulation of Soil Parameters

Layer	Label	Allowable Bearing Pressure (q_a) (psf)	Allowable Lateral Pressure (R) (psf/ft)
1	Sand, silty sand, clayey sand, silty gravel & clayey gravel	2000.000	150.000

Tabulation of Loads

Load Component	ASD	LRFD
P (kip)	7.046	10.383
V_x (kip)	-3.766	-6.277
V_z (kip)	0.000	0.000
M_x (kipft)	0.000	0.000
M_z (kipft)	31.825	53.238

Material Properties

$f'_{ck} = 2.5$ ksi - Concrete strength.

Required depth to resist lateral loads (ASD)

H - Point of application of the lateral load

$$H = h_1 + h_2 + h_e$$

$$H = (0 \text{ ft}) + (0 \text{ ft}) + (0 \text{ ft})$$

$$H = 0 \text{ ft}$$

Considering x-direction:

H_o - Lateral force per length of pile,

$$H_o = \frac{V_x}{1.57 D}$$

$$H_o = \frac{(-3.766 \text{ kip})}{1.57 \times (48 \text{ in})}$$

$$H_o = -0.59968 \text{ kip/ft}$$

M_o - Moment per length of pile,

$$M_o = \frac{M_z + (V_x H)}{1.57 D}$$

$$M_o = \frac{(31.825 \text{ kipft}) + ((-3.766 \text{ kip}) \times (0 \text{ ft}))}{1.57 \times (48 \text{ in})}$$

$$M_o = 5.0677 \text{ kipft/ft}$$

Required depth of embedment in earth:

$$L_x^3 - \left(14.14 \times \frac{H_o \times L_x}{R}\right) - \left(18.85 \times \frac{M_o}{R}\right) = 0$$

Solving the cubic equation:

$L_{e,x} = 5.8118 \text{ ft}$ - Required depth in x-direction,

Considering z-direction:

$L_{e,z} = 0 \text{ ft}$ - Required depth in z-direction,

Minimum embedded depth required:

$L_{e,req}$ - Depth of pile required,

$$L_{e,req} = \text{MAX}[L_{e,x}, L_{e,z}]$$

$$L_{e,req} = \text{MAX}[(5.8118 \text{ ft}), (0 \text{ ft})]$$

$$L_{e,req} = 5.812 \text{ ft}$$

L_e - Actual embedded length of pile,

$$L_e = L - h_e - h_2$$

$$L_e = (6.5 \text{ ft}) - (0 \text{ ft}) - (0 \text{ ft})$$

$$L_e = 6.5 \text{ ft}$$

Ratio - Embedded depth

$$\text{Ratio} = \frac{L_{e,req}}{L_e}$$

$$\text{Ratio} = \frac{(5.812 \text{ ft})}{(6.5 \text{ ft})}$$

$$\text{Ratio} = 0.89415$$

Status: **PASS**
Ratio: **0.890**

End-bearing Capacity (ASD)

A - Pile cross-section area

$$A = b D$$

$$A = (48 \text{ in}) \times (48 \text{ in})$$

$$A = 16 \text{ ft}^2$$

q - End-bearing pressure

$$q = \frac{P_v}{A}$$

$$q = \frac{(7.046 \text{ kip})}{(16 \text{ ft}^2)}$$

$$q = 0.44038 \text{ kip/ft}^2$$

Check bearing capacity ratio:

Ratio - Capacity

$$\text{Ratio} = \frac{q}{q_a}$$

$$\text{Ratio} = \frac{(0.44038 \text{ kip/ft}^2)}{(2000 \text{ psf})}$$

$$\text{Ratio} = 0.22019$$

Status: **PASS**
Ratio: **0.220**

Czerniak

Lateral Soil Pressure (ASD):

L/D - Length to least lateral dimension ratio,

$$L/D = \frac{L}{D}$$

$$L/D = \frac{(6.5 \text{ ft})}{(48 \text{ in})}$$

$$L/D = 1.625$$

Since $L/D \leq 10$,

Pile is short.

Considering x-direction:

$H_o = -0.59968 \text{ kip/ft}$ - Lateral force per length of pile,

$M_o = 5.0677 \text{ kipft/ft}$ - Overturning moment per length of pile,

a - Distance from resting surface to pivot point,

$$a = \frac{(4 M_o L_e) + (3 H_o L_e^2)}{(6 M_o) + (4 H_o L_e)}$$

$$a = \frac{(4 \times (5.0677 \text{ kipft/ft}) \times (6.5 \text{ ft})) + (3 \times (-0.59968 \text{ kip/ft}) \times (6.5 \text{ ft})^2)}{(6 \times (5.0677 \text{ kipft/ft})) + (4 \times (-0.59968 \text{ kip/ft}) \times (6.5 \text{ ft}))}$$

$$a = 4.5169 \text{ ft}$$

p - Earth pressure against the pile at distance $a/2$ from resting surface,

$$p = \frac{0.75 [(4 M_o) + (3 H_o L_e)]^2}{L_e^2 [(3 M_o) + (2 H_o L_e)]}$$

$$p = \frac{0.75 \times [(4 \times (5.0677 \text{ kipft/ft})) + (3 \times (-0.59968 \text{ kip/ft}) \times (6.5 \text{ ft}))]^2}{(6.5 \text{ ft})^2 \times [(3 \times (5.0677 \text{ kipft/ft})) + (2 \times (-0.59968 \text{ kip/ft}) \times (6.5 \text{ ft}))]}$$

$$p = 0.1763 \text{ kip/ft}^2$$

s - Earth pressure against the pile at distance L_e ,

$$s = \frac{6 [(2 M_o) + (H_o L_e)]}{L_e^2}$$

$$s = \frac{6 \times [(2 \times (5.0677 \text{ kipft/ft})) + ((-0.59968 \text{ kip/ft}) \times (6.5 \text{ ft}))]}{(6.5 \text{ ft})^2}$$

$$s = 0.88579 \text{ kip/ft}^2$$

Check lateral soil pressure capacity:

p_a - Allowable lateral soil pressure at depth $a/2$,

$$p_a = R \frac{a}{2}$$

$$p_a = (150 \text{ psf/ft}) \times \frac{(4.5169 \text{ ft})}{2}$$

$$p_a = 0.33877 \text{ kip/ft}^2$$

Ratio - Lateral soil capacity

$$\text{Ratio} = \frac{p}{p_a}$$

$$\text{Ratio} = \frac{(0.1763 \text{ kip/ft}^2)}{(0.33877 \text{ kip/ft}^2)}$$

$$\text{Ratio} = 0.5204$$

p_s - Allowable lateral soil pressure at depth L_e ,

$$p_s = R L_e$$

$$p_s = (150 \text{ psf/ft}) \times (6.5 \text{ ft})$$

$$p_s = 0.975 \text{ kip/ft}^2$$

Ratio - Lateral soil capacity

$$\text{Ratio} = \frac{s}{p_s}$$

$$\text{Ratio} = \frac{(0.88579 \text{ kip/ft}^2)}{(0.975 \text{ kip/ft}^2)}$$

Status: **PASS**
Ratio: **0.520**

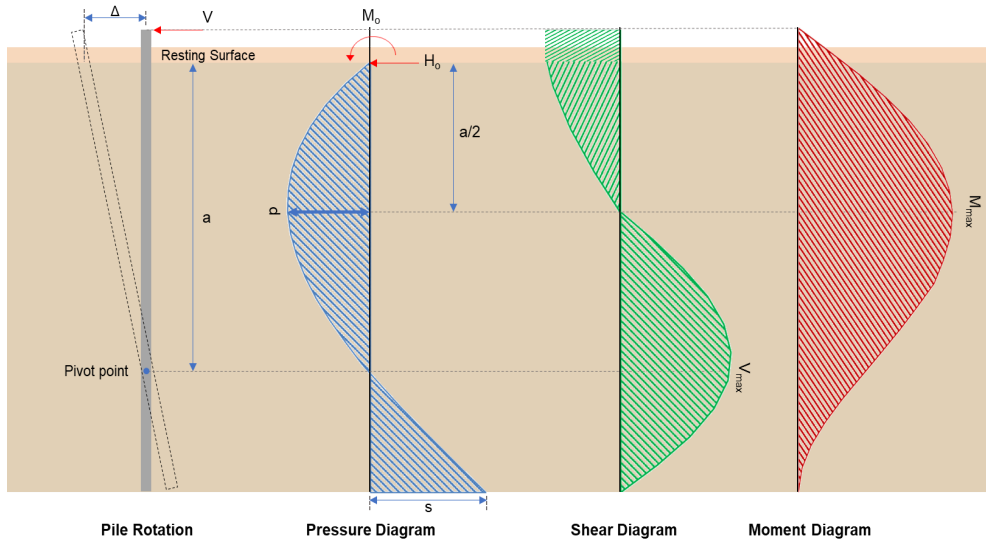

Shear force and Bending moment (x-direction, LRFD)

H_o - Lateral force per length of pile,

$$H_o = \frac{V_x}{1.57 D}$$

$$H_o = \frac{(-6.277 \text{ kip})}{1.57 \times (48 \text{ in})}$$

$$H_o = -0.99952 \text{ kip/ft}$$

M_o - Moment per length of pile,

$$M_o = \frac{M_z + (V_x H)}{1.57 D}$$

$$M_o = \frac{(53.238 \text{ kipft}) + ((-6.277 \text{ kip}) \times (0 \text{ ft}))}{1.57 \times (48 \text{ in})}$$

$$M_o = 8.4774 \text{ kipft/ft}$$

E - Distance from lateral load to resisting surface,

$$E = \frac{M_o}{H_o}$$

$$E = \frac{(8.4774 \text{ kipft/ft})}{(-0.99952 \text{ kip/ft})}$$

$$E = 8.4814 \text{ ft}$$

a - Distance from resting surface to pivot point,

$$a = \frac{(4 M_o L_e) + (3 H_o L_e^2)}{(6 M_o) + (4 H_o L_e)}$$

$$a = \frac{(4 \times (8.4774 \text{ kipft/ft}) \times (6.5 \text{ ft})) + (3 \times (-0.99952 \text{ kip/ft}) \times (6.5 \text{ ft})^2)}{(6 \times (8.4774 \text{ kipft/ft})) + (4 \times (-0.99952 \text{ kip/ft}) \times (6.5 \text{ ft}))}$$

$$a = 4.5165 \text{ ft}$$

V_{max} - Max shear force located at depth a ,

$$V_{max} = (H_o D) \left[1 - \left[3 \left(\frac{4E}{L_e} + 3 \right) \left(\frac{a}{L_e} \right)^2 \right] + \left[4 \left(\frac{3E}{L_e} + 2 \right) \left(\frac{a}{L_e} \right)^3 \right] \right]$$

$$V_{max} = ((-0.99952 \text{ kip/ft}) \times (48 \text{ in})) \times \left[1 - \left[3 \times \left(\frac{4 \times (8.4814 \text{ ft})}{(6.5 \text{ ft})} + 3 \right) \times \left(\frac{(4.5165 \text{ ft})}{(6.5 \text{ ft})} \right)^2 \right] + \left[4 \times \left(\frac{3 \times (8.4814 \text{ ft})}{(6.5 \text{ ft})} + 2 \right) \times \left(\frac{(4.5165 \text{ ft})}{(6.5 \text{ ft})} \right)^3 \right] \right]$$

$$V_{max} = 11.000 \text{ kip}$$

M_{max} - Max bending moment located at depth $a/2$,

$$M_{max} = (H_o D L_e) \left[\left(\frac{E}{L_e} + \frac{a}{2 L_e} \right) - \left[\left(\frac{4E}{L_e} + 3 \right) \left(\frac{a}{2 L_e} \right)^3 + \left[\left(\frac{3E}{L_e} + 2 \right) \left(\frac{a}{2 L_e} \right)^4 \right] \right]$$

$$M_{max} = ((-0.99952 \text{ kip/ft}) \times (48 \text{ in}) \times (6.5 \text{ ft})) \times \left[\left(\frac{(8.4814 \text{ ft})}{(6.5 \text{ ft})} + \frac{(4.5165 \text{ ft})}{2 \times (6.5 \text{ ft})} \right) - \left[\left(\frac{4 \times (8.4814 \text{ ft})}{(6.5 \text{ ft})} + 3 \right) \times \left(\frac{(4.5165 \text{ ft})}{2 \times (6.5 \text{ ft})} \right)^3 + \left[\left(\frac{3 \times (8.4814 \text{ ft})}{(6.5 \text{ ft})} + 2 \right) \times \left(\frac{(4.5165 \text{ ft})}{2 \times (6.5 \text{ ft})} \right)^4 \right] \right]$$

$$M_{max} = 36.22 \text{ kipft}$$

Minimum Reinforcement Check (LRFD)

Parameters:

$f'_{ck} = 2.5 \text{ ksi}$ - Concrete strength,
 $f_{yk} = 60 \text{ ksi}$ - Longitudinal reinforcement strength,
 $\phi = 0.65$ - Reduction factor for axial strength,
 $\alpha = 0.8$ - Alpha factor for axial strength,
 $A_g = 2304 \text{ in}^2$ - Gross area of concrete,

Table 22.4.2.1

Longitudinal reinforcement:

Required reinforcement due to axial load, $A_{st,required}$

22.4.2.2, 10.6.1.1

$A_{st,required}$

$$A_{st,required} = \text{Min} \left[\frac{\frac{P}{\phi \alpha} - (0.85 f'_{ck} A_g)}{f_{yk} - (0.85 f'_{ck})}, (0.08 A_g) \right]$$

$$A_{st,required} = \text{Min} \left[\frac{\left(\frac{10.383 \text{ kip}}{(0.65) \times (0.8)} \right) - (0.85 \times (2.5 \text{ ksi}) \times (2304 \text{ in}^2))}{(60 \text{ ksi}) - (0.85 \times (2.5 \text{ ksi}))}, (0.08 \times (2304 \text{ in}^2)) \right]$$

$$A_{st,required} = -84.251 \text{ in}^2$$

A_{min} - Governing minimum reinforcement area,

$$A_{min} = \text{Max} [A_{st,required}, (0.0018 A_g)]$$

$$A_{min} = \text{Max} [(-84.251 \text{ in}^2), (0.0018 \times (2304 \text{ in}^2))]$$

$$A_{min} = 4.1472 \text{ in}^2$$

n_{rebar} - Required number of reinforcement,

$$n_{rebar} = \frac{A_{min}}{A_{rebar}}$$

$$n_{rebar} = \frac{(4.1472 \text{ in}^2)}{(0.3068 \text{ in}^2)}$$

$$n_{rebar} = 14$$

A_{st} - Actual total reinforcement area,

$$A_{st} = n_{rebar} \frac{\pi d_{bar}^2}{4}$$

$$A_{st} = (14) \times \frac{\pi \times (0.625 \text{ in})^2}{4}$$

$$A_{st} = 4.2951 \text{ in}^2$$

Ratio - Capacity

$$\text{Ratio} = \frac{A_{min}}{A_{st}}$$

$$\text{Ratio} = \frac{(4.1472 \text{ in}^2)}{(4.2951 \text{ in}^2)}$$

$$\text{Ratio} = 0.96556$$

25.2.3

s_{rebar} - Minimum spacing of reinforcement,

$$s_{rebar} = \text{Max} [1.5, (1.5 d_{bar})]$$

Status: **PASS**
Ratio: **0.970**

$$s_{rebar} = Max[1.5, (1.5 \times (0.625 \text{ in}))]$$

$$s_{rebar} = 1.5 \text{ in}$$

Ties:

25.7.2.2 Since longitudinal reinforcement is \leq No. 10 \emptyset : Use #3(0.375 in)

25.7.2.1 s_{ties} - Maximum spacing of ties,

$$s_{ties} = Min[(16 d_{bar}), (48 d_{ties}), Min(D, b)]$$

$$s_{ties} = Min[(16 \times (0.625 \text{ in})), (48 \times (0.375 \text{ in})), Min((48 \text{ in}), (48 \text{ in}))]$$

$$s_{ties} = 10 \text{ in}$$

Summary:

Main reinforcement: **14 - #5 (0.625 in)**

Ties: **#3(0.375 in) - 10 in**

Axial Compression Strength (ACI 318-19, LRFD)

22.4.2.2 ϕP_N - Allowable axial compressive strength

$$\phi P_N = \phi 0.80 [(0.85 f'_{ck} [A_g - A_{st}]) + (f_{yk} A_{st})]$$

$$\phi P_N = (0.65) \times 0.80 \times [(0.85 \times (2.5 \text{ ksi}) \times [(2304 \text{ in}^2) - (4.2951 \text{ in}^2)]) + ((60 \text{ ksi}) \times (4.2951 \text{ in}^2))]$$

$$\phi P_N = 2675.2 \text{ kip}$$

Ratio - Capacity

$$Ratio = \frac{P}{\phi P_N}$$

$$Ratio = \frac{(10.383 \text{ kip})}{(2675.2 \text{ kip})}$$

$$Ratio = 0.0038812$$

Status: **PASS**
Ratio: **0.000**

Shear Strength (ACI 318-19, LRFD)

Parameters:

22.5.2.2 $b_w = 48 \text{ in}$ - Effective width,
 d - Effective depth

$$d = 0.80 D$$

$$d = 0.80 \times (48 \text{ in})$$

$$d = 38.4 \text{ in}$$

22.5.5.1.3 λ_s - size effect modification factor

$$\lambda_s = MIN \left[\sqrt{\frac{2}{1 + \frac{d}{10}}}, 1 \right]$$

$$\lambda_s = MIN \left[\sqrt{\frac{2}{1 + \frac{(38.4 \text{ in})}{10}}}, 1 \right]$$

$$\lambda_s = 0.64282$$

The following variables were converted to be consistent with empirical formula $f'_{ck} = 2.5 \text{ ksi} \rightarrow 2500 \text{ psi}$,

22.5.5.1.1 $V_{c,max}$ - Max shear strength of concrete

$$V_{c,max} = 5 \lambda_s \sqrt{f'_{ck}} b_w d$$

$$V_{c,max} = 5 \times (0.64282) \times \sqrt{(2500 \text{ psi})} \times (48 \text{ in}) \times (38.4 \text{ in})$$

$$V_{c,max} = 296.21 \text{ kip}$$

The following variables were converted to be consistent with empirical formula $f'_{ck} = 2.5 \text{ ksi} \rightarrow 2500 \text{ psi}$, $P = 10.383 \text{ kip} \rightarrow 10383 \text{ lbf}$,

22.5.5.1.1(a) $V_{c,a}$ - Shear strength of concrete (a)

$$V_{c,a} = \left[2 \lambda_s \sqrt{f'_{ck}} + \frac{P}{6 A_g} \right] b_w d$$

$$V_{c,a} = \left[2 \times (0.64282) \times \sqrt{(2500 \text{ psi})} + \frac{(10383 \text{ lbf})}{6 \times (2304 \text{ in}^2)} \right] \times (48 \text{ in}) \times (38.4 \text{ in})$$

$$V_{c,a} = 119.87 \text{ kip}$$

22.5.5.1.2 The following variables were converted to be consistent with empirical formula $f'_{ck} = 2.5 \text{ ksi} \rightarrow 2500 \text{ psi}$,
 $V_{c,b}$ - Shear strength of concrete (b)

$$V_{c,b} = \left[2 \lambda_s \sqrt{f'_{ck}} + (0.05 f'_{ck}) \right] b_w d$$

$$V_{c,b} = \left[2 \times (0.64282) \times \sqrt{(2500 \text{ psi})} + (0.05 \times (2500 \text{ psi})) \right] \times (48 \text{ in}) \times (38.4 \text{ in})$$

$$V_{c,b} = 348.89 \text{ kip}$$

V_c - Governing shear strength of concrete

$$V_c = \text{Min}[V_{c,max}, V_{c,a}, V_{c,b}]$$

$$V_c = \text{Min}[(296.21 \text{ kip}), (119.87 \text{ kip}), (348.89 \text{ kip})]$$

$$V_c = 119.87 \text{ kip}$$

22.5.1.2 The following variables were converted to be consistent with empirical formula $f'_{ck} = 2.5 \text{ ksi} \rightarrow 2500 \text{ psi}$,
 $V_{s,a}$ - Shear strength of steel (a)

$$V_{s,a} = 8 \sqrt{f'_{ck}} b_w d$$

$$V_{s,a} = 8 \times \sqrt{(2500 \text{ psi})} \times (48 \text{ in}) \times (38.4 \text{ in})$$

$$V_{s,a} = 737.28 \text{ kip}$$

A_v - Ties rebar area,

$$A_v = \frac{\pi d_{ties}^2}{4}$$

$$A_v = \frac{\pi \times (0.375 \text{ in})^2}{4}$$

$$A_v = 0.11045 \text{ in}^2$$

22.5.8.5.3 $V_{s,b}$ - Shear strength of steel (b)

$$V_{s,b} = \frac{2 A_v f_{ywk} d}{s_{ties}}$$

$$V_{s,b} = \frac{2 \times (0.11045 \text{ in}^2) \times (60 \text{ ksi}) \times (38.4 \text{ in})}{(10 \text{ in})}$$

$$V_{s,b} = 50.894 \text{ kip}$$

V_s - Governing shear strength of steel

$$V_s = \text{MIN}[V_{s,a}, V_{s,b}]$$

$$V_s = \text{MIN}[(737.28 \text{ kip}), (50.894 \text{ kip})]$$

$$V_s = 50.894 \text{ kip}$$

22.5.1.1 ϕV_n - Allowable shear strength

$$\phi V_n = \phi (V_c + V_s)$$

$$\phi V_n = (0.65) \times ((119.87 \text{ kip}) + (50.894 \text{ kip}))$$

$$\phi V_n = 111 \text{ kip}$$

Considering x-direction:

$V_{max} = 11.868 \text{ kip}$ - Maximum shear force in the x-direction,

Ratio - Capacity

$$\text{Ratio} = \frac{V_{max}}{\phi V_n}$$

$$\text{Ratio} = \frac{(11.868 \text{ kip})}{(111 \text{ kip})}$$

$$\text{Ratio} = 0.10692$$

Status: **PASS**
 Ratio: **0.110**

Flexural Strength (ACI 318-19, LRFD)

S_m - Section modulus

$$S_m = \frac{b D^2}{6}$$

$$S_m = \frac{(48 \text{ in}) \times (48 \text{ in})^2}{6}$$

$$S_m = 18432 \text{ in}^3$$

$\lambda = 1$ - Concrete modification factor (Normal concrete),

Allowable flexural strength:

M_n shall be the lesser of:

$\phi M_{n,1}$

$$\phi M_{n,1} = \phi \times 5 \times \lambda \times \sqrt{f'_c} \times S_m$$

$$\phi M_{n,1} = 0.65 \times 5 \times 1 \times \sqrt{2.5 \text{ ksi}} \times 18432.001 \text{ in}^3$$

$$\phi M_{n,1} = 249.600 \text{ kipft}$$

14.5.2.1b

$\phi M_{n,2}$

$$\phi M_{n,2} = \phi \times 0.85 \times f'_c \times S_m$$

$$\phi M_{n,2} = (0.65) \times 0.85 \times (2.5 \text{ ksi}) \times (18432 \text{ in}^3)$$

$$\phi M_{n,2} = 2121.6 \text{ kipft}$$

Therefore,

ϕM_n - Allowable flexural strength,

$$\phi M_n = \text{MIN}[\phi M_{n,1}, \phi M_{n,2}]$$

$$\phi M_n = \text{MIN}[(249.6 \text{ kipft}), (2121.6 \text{ kipft})]$$

$$\phi M_n = 249.6 \text{ kipft}$$

Considering x-direction:

$M_{max} = 36.22 \text{ kipft}$ - Maximum moment in the x-direction,

Ratio - Capacity

$$\text{Ratio} = \frac{M_{max}}{\phi M_n}$$

$$\text{Ratio} = \frac{(36.22 \text{ kipft})}{(249.6 \text{ kipft})}$$

$$\text{Ratio} = 0.14511$$

Status: **PASS**
Ratio: **0.150**