

Project Name: Terrapin Ridge-ExpC-v4cu

Date: Thu May 29 2025

Location: R6WM+7HJ, Rochester, VT, USA

Number of Modules: 12

Unique ID: 1P-0-10TOP-XD-84-L-4Hx3W-STRUTS-4IEI

Number of Poles: 1

Date Sold:

Dealer: _____

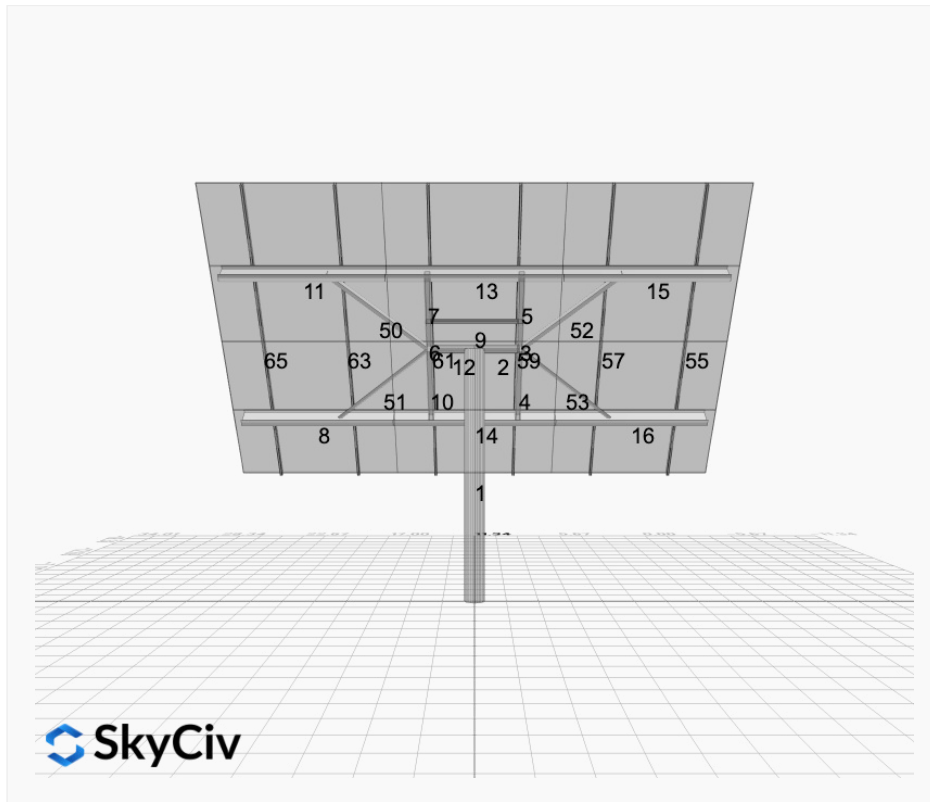

Array Dimensions N/S	15.05 ft
Array Dimensions E/W	22.67 ft
Winter Tilt Angle	55
Front Edge Clearance	5 ft

MT Solar Bill of Materials (1P-0-10TOP-XD-84-L-4Hx3W-STRUTS-4IEI)

Part	Short Description	BOM Qty
MTS-PC-10	10IN Pole Cap Assembly	1
MTS-HF-XD	H-Frame Assembly-XD	1
MTS-XD-Wing-84	84IN XD Wing	4
MTS-CLAMP-HOOK-4PK	Hook Clamp	3

Rail Bill of Materials

Part	Qty
Rails (181in)	6
Rail Attachment	12
Module Mid Clamp	18
Module End Clamp	12
Ground Lug	3

Site Details:

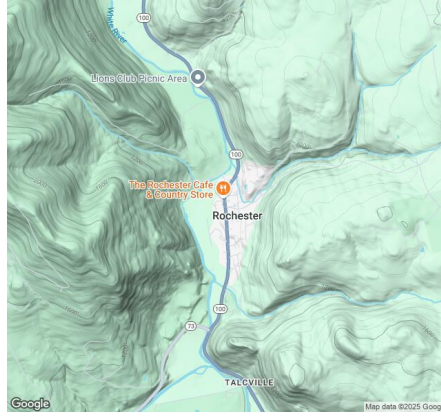

Site Address: R6WM+7HJ, Rochester, VT, USA

Array Specification

Duty Classification:	XD
Module Width:	44.65 in
Module Length:	89.69in
Number of Rows:	4
Number of Columns:	3
Total Number of Modules:	12
Winter Tilt Angle:	55
Front Edge Clearance:	5
Total Array Height at Tilt:	17.33 ft
Total Frame Length:	21.50 ft
Module Info/Notes:	
Array Dimensions N/S:	15.05 ft
Array Dimensions E/W:	22.67 ft
Rail Length:	180.60 in
Rail Spacing:	3.78 ft

Support Specifications

Pole Size:	10in Pipe Sch 40
Pole Length above Grade:	11.16 ft
Number of Poles:	1
Pole Spacing:	0

Foundation Specifications

Foundation Type:	Square
Foundation Dimensions:	48 x 48 in
Foundation Depth (below grade):	Pile 1: 8.50 ft
Foundation Volume:	5.037 y ³

Site Info

Risk Category:	I
Exposure:	C
Soil Classification:	sand
Site Location:	R6WM+7HJ, Rochester, VT, USA
Wind Speed:	110 mph
Snow Load:	70 psf

Design Disclaimer

This software should be used for preliminary designs and should not be used as a final design unless reviewed, verified and designed by a qualified structural engineer.

AutoDesigner Input

```
{ "wind_speed_override": 110, "snow_load_override": 70, "direct_snow_load": false, "add_angle_brace": true, "product_type": "Beam", "designer_name": "Amos Post", "designer_email": "amos@ienergyvt.com", "designer_phone": "802-291-2188", "project_id": "Terrapin Ridge-ExpC-v4cu", "site_address": "R6WM+7HJ, Rochester, VT, USA", "module_info": "", "module_width": 44.65, "module_length": 89.69, "number_rows": 4, "number_columns": 3, "pole_mount_section": "4_40", "core_pipe_width": 65, "core_pipe_section": "2_40", "adjuster_section": "2_40", "core_beam_height": 65, "core_beam_section": "HSS3x2x1/8", "main_pipe_section": "2_12GA", "pole_spacing": "15", "tilt_angle": 55, "ground_clearance": 5, "risk_category": "I", "exposure_category": "C", "frame_duty_override": "auto", "pole_override": "auto", "soil_type": "sand", "customer_foundation_override": "48_Square", "foundation_type": "Square", "foundation_size": 48, "check_rails": false }
```

Design Notes:

- AISC Deflection checks are set to L/1 due to structure design intent
- Foundation Soil Parameters used in this Autodesign are all estimates, proper geotechnical reports are required to confirm soil profiles
- Wind speeds, snow loads and other site specific results are based on ASCE 7 2016
- Steel frame design checks are based on AISC 360 2016 (LRFD)

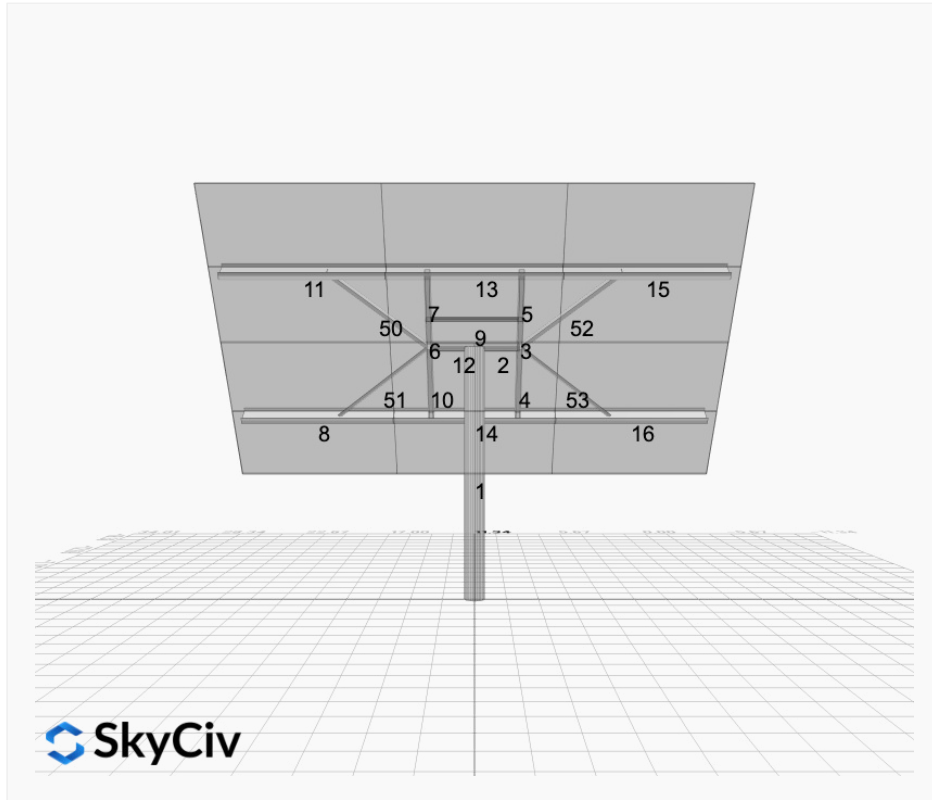

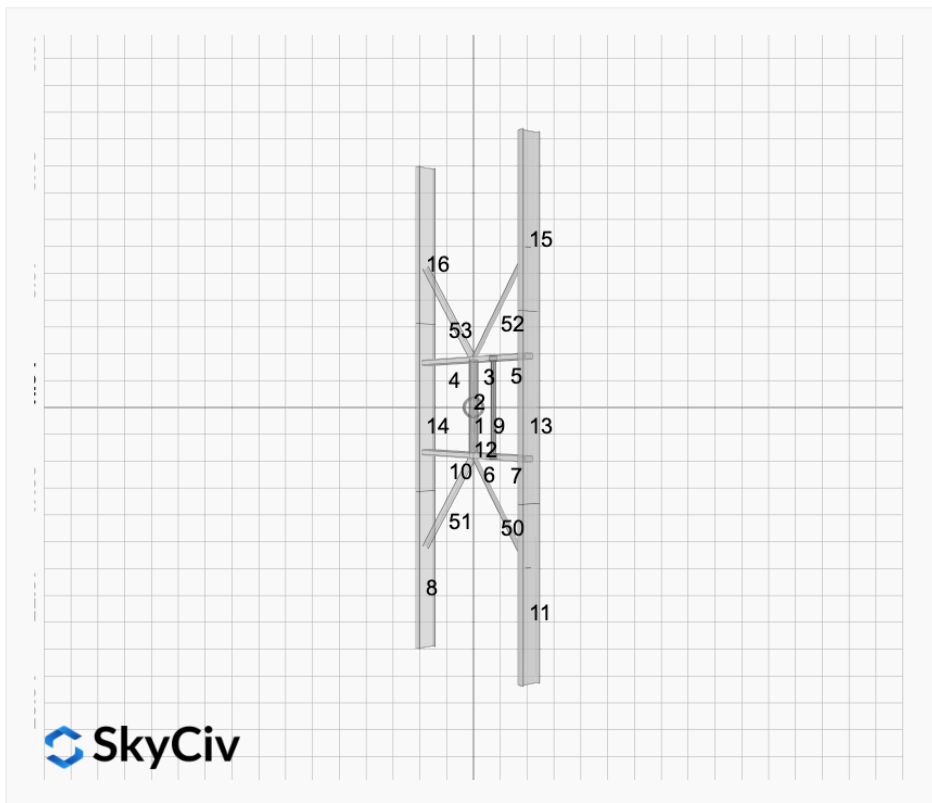
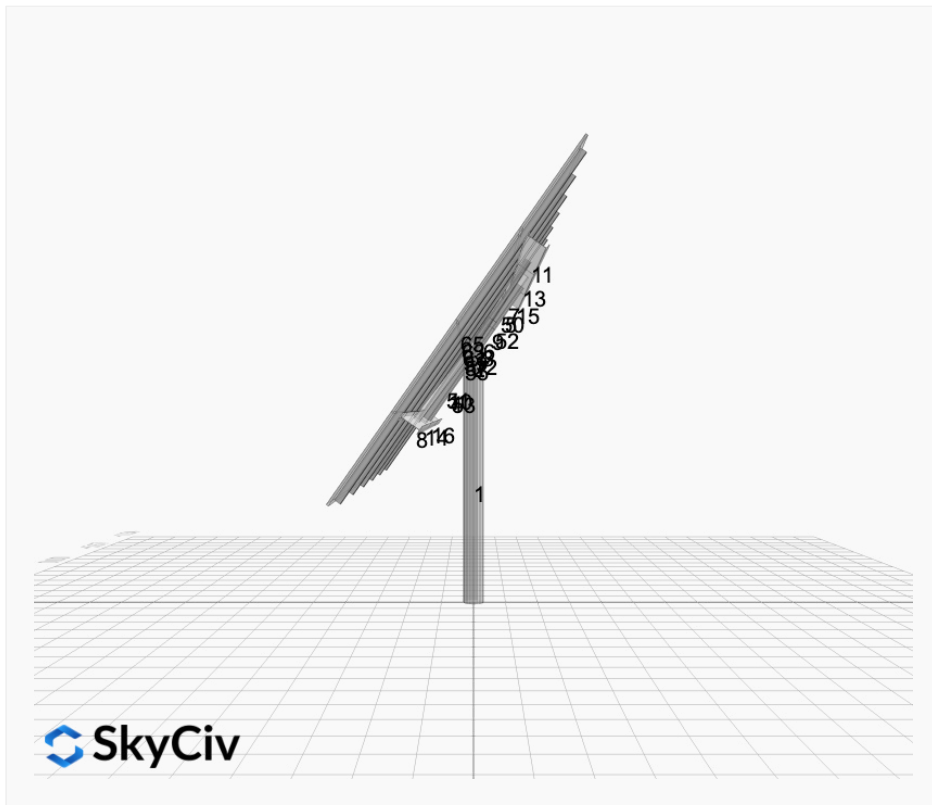

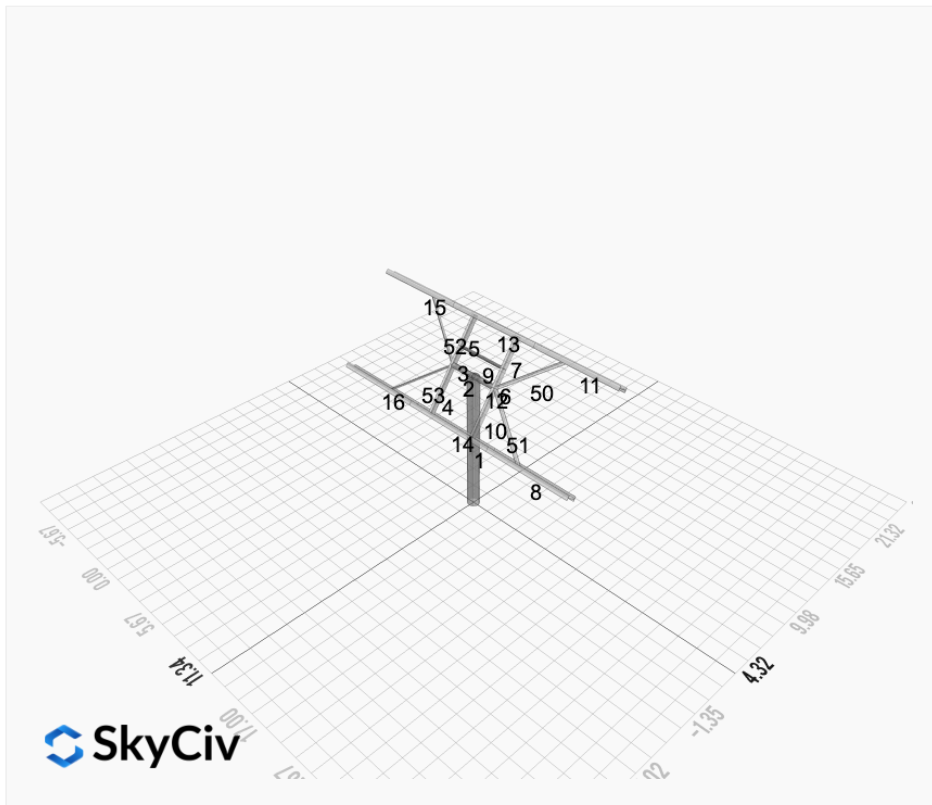

FEM Results (Envelope Worst Case for each member)

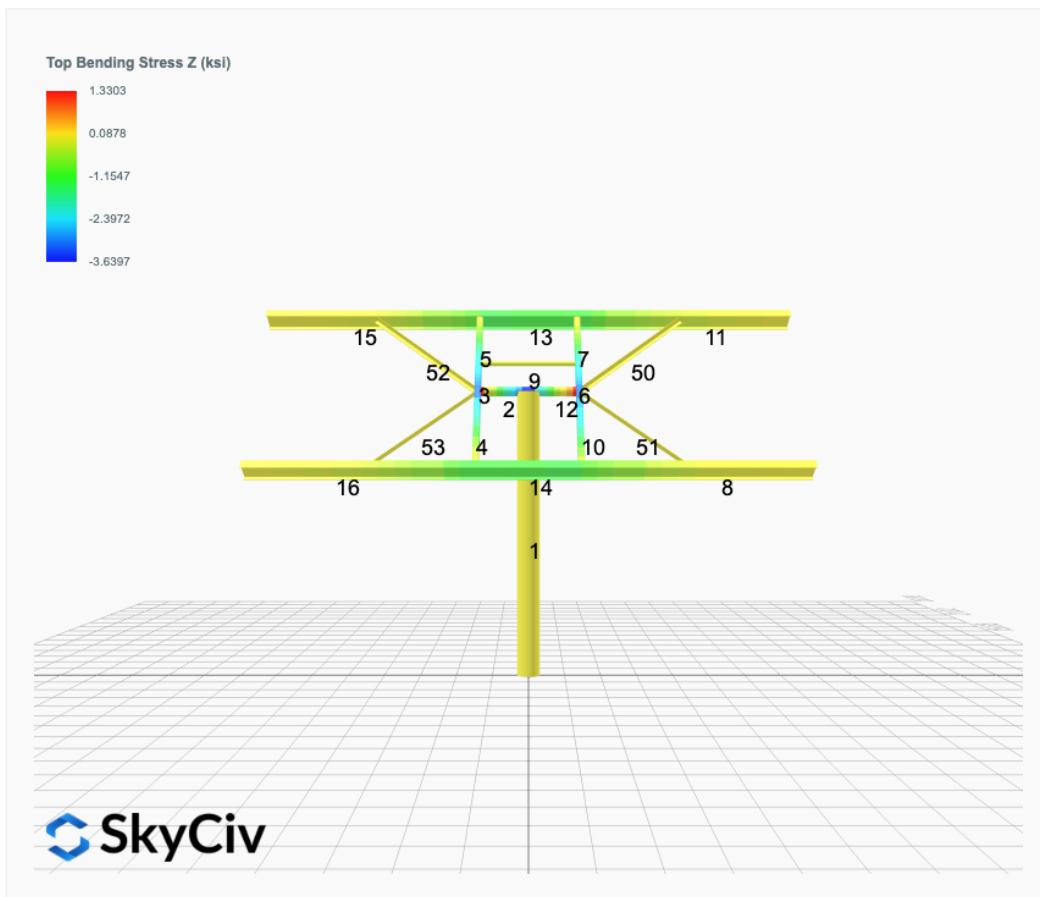
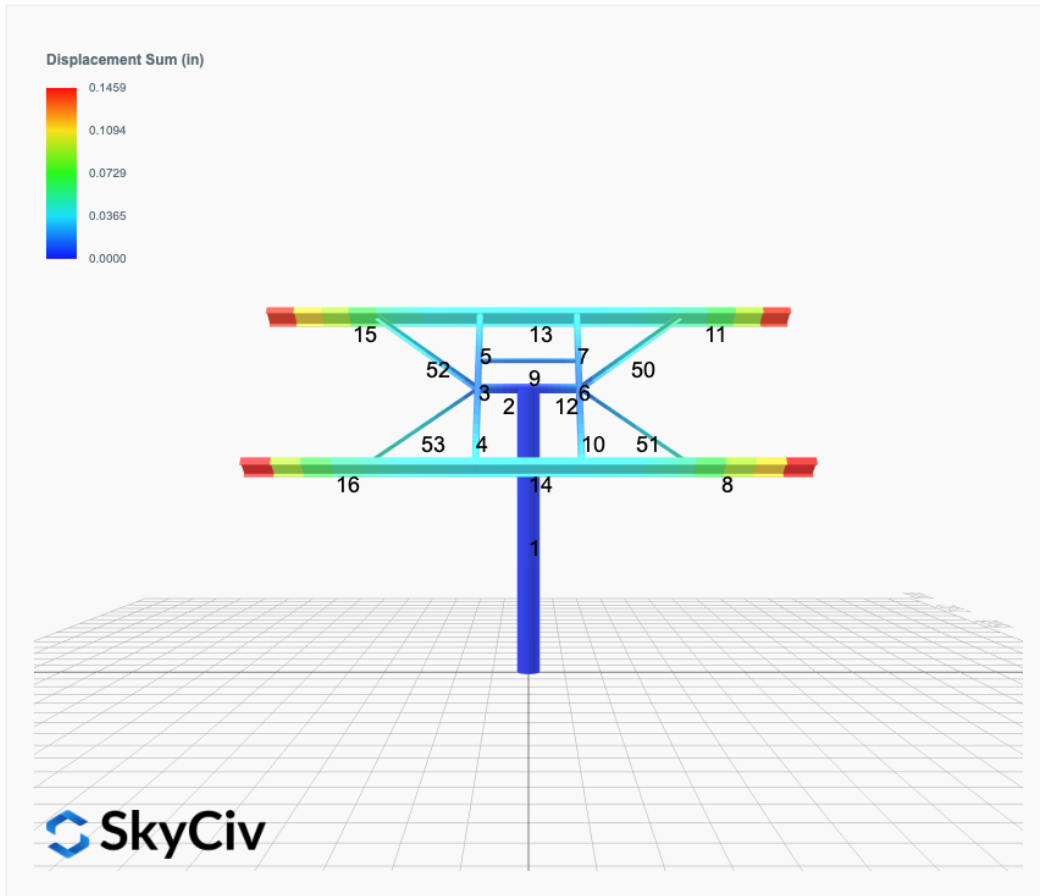

Top Bending Stress Y (ksi)

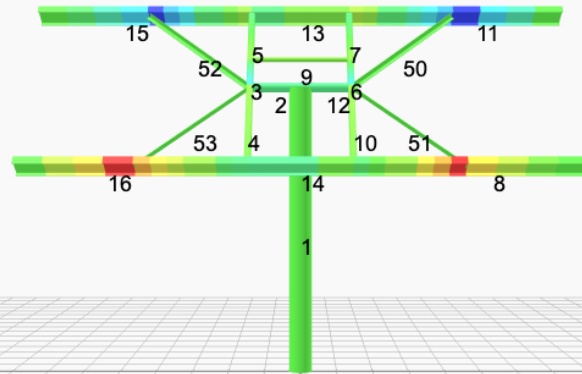

Shear Stress Y (ksi)

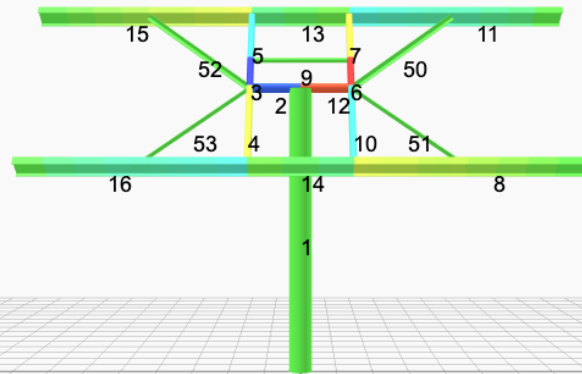

Axial Stress (ksi)

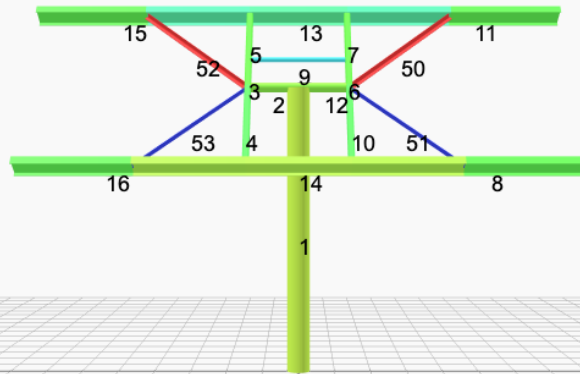
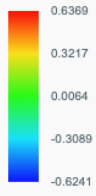

Reaction Forces for Foundation 1 (Node ID#1), (kip, kip-ft)

ASD Load Combination Results

Name	Fx	Fy	Fz	Mx	My	Mz
ULS: 1. D	0.0000	2.8566	0.0000	-0.0000	-0.0000	0.0225
ULS: 2. D + L	0.0000	2.8566	0.0000	-0.0000	-0.0000	0.0225
ULS: 3. D + (S or Lr or R)	0.0000	4.9995	0.0000	-0.0000	-0.0000	0.0293
ULS: 3. D + (S or Lr or R)	0.0000	2.8566	0.0000	-0.0000	-0.0000	0.0225
ULS: 4. D + 0.75L + 0.75(S or Lr or R)	0.0000	4.4638	0.0000	-0.0000	-0.0000	0.0276
ULS: 4. D + 0.75L + 0.75(S or Lr or R)	0.0000	2.8566	0.0000	-0.0000	-0.0000	0.0225
ULS: 5b. D + 0.7E	0.0000	2.8566	0.0000	-0.0000	-0.0000	0.0225
ULS: 6b. D + 0.75L + 0.75(0.7)E + 0.75S	0.0000	4.4638	0.0000	-0.0000	-0.0000	0.0276
ULS: 8. 0.6D + 0.7E	0.0000	1.7140	0.0000	-0.0000	-0.0000	0.0135
ULS: 5a. D + 0.6W_Wind downforce Case A only	-6.7825	7.6058	0.0000	-0.0000	-0.0000	76.5218
ULS: 5a. D + 0.6W_Wind downforce Case B only	0.0000	2.8566	0.0000	-0.0000	-0.0000	0.0225
ULS: 5a. D + 0.6W_Wind uplift Case A only	6.7825	-1.8925	0.0000	-0.0000	-0.0000	-74.9380
ULS: 5a. D + 0.6W_Wind uplift Case B only	0.0000	2.8566	0.0000	-0.0000	-0.0000	0.0225
ULS: 6a. D + 0.75L + 0.75(0.6)W + 0.75(S or Lr or R)_Wind downforce Case A only	-5.0869	8.0257	0.0000	-0.0000	-0.0000	57.4021
ULS: 6a. D + 0.75L + 0.75(0.6)W + 0.75(S or Lr or R)_Wind downforce Case B only	0.0000	4.4638	0.0000	-0.0000	-0.0000	0.0276
ULS: 6a. D + 0.75L + 0.75(0.6)W + 0.75(S or Lr or R)_Wind uplift Case A only	5.0869	0.9020	0.0000	-0.0000	-0.0000	-56.1928
ULS: 6a. D + 0.75L + 0.75(0.6)W + 0.75(S or Lr or R)_Wind uplift Case B only	0.0000	4.4638	0.0000	-0.0000	-0.0000	0.0276
ULS: 6a. D + 0.75L + 0.75(0.6)W + 0.75(S or Lr or R)_Wind downforce Case A only	-5.0869	6.4185	0.0000	-0.0000	-0.0000	57.3970
ULS: 6a. D + 0.75L + 0.75(0.6)W + 0.75(S or Lr or R)_Wind downforce Case B only	0.0000	2.8566	0.0000	-0.0000	-0.0000	0.0225
ULS: 6a. D + 0.75L + 0.75(0.6)W + 0.75(S or Lr or R)_Wind uplift Case A only	5.0869	-0.7052	0.0000	-0.0000	-0.0000	-56.1979
ULS: 6a. D + 0.75L + 0.75(0.6)W + 0.75(S or Lr or R)_Wind uplift Case B only	0.0000	2.8566	0.0000	-0.0000	-0.0000	0.0225
ULS: 7. 0.6D + 0.6W_Wind downforce Case A only	-6.7825	6.4631	0.0000	-0.0000	-0.0000	76.5128
ULS: 7. 0.6D + 0.6W_Wind downforce Case B only	0.0000	1.7140	0.0000	-0.0000	-0.0000	0.0135
ULS: 7. 0.6D + 0.6W_Wind uplift Case A only	6.7825	-3.0352	0.0000	-0.0000	-0.0000	-74.9470
ULS: 7. 0.6D + 0.6W_Wind uplift Case B only	0.0000	1.7140	0.0000	-0.0000	-0.0000	0.0135

Worst Case Reactions LRFD

These calculations are taken directly from the FEA via SkyCiv and are used in the Concrete Checks of the Foundation Module.

Note: Worst case values are assumed as downforce wind load cases.

Result	Value (kip, kip-ft)
Axial	12.4147
Shear X	-11.3042
Shear Z	0.0000
Moment X	-0.0016
Moment Y (Twist)	0.0006
Moment Z	128.4269

Worst Case Reactions ASD

These results are taken from the worst case values in the above table and are used in the Soil Checks in the Foundation Module.

Note: Worst case values are assumed as downforce wind load cases.

Result	Value (kip, kip-ft)
Axial	8.0257
Shear X	-6.7825
Shear Z	0.0000
Moment X	-0.0000
Moment Y (Twist)	0.0000
Moment Z	76.5218

Project Details

Design Code: AISC 360-16 LRFD
 Provision: LRFD
 Country: United States
 User Name: sales@mtsolar.us
 Unit System: imperial



Design Input Information

Design Factors			
Φ_t	Φ_c	Φ_b	Φ_v
0.9	0.9	0.9	0.9

Design Materials			
ID	E (ksi)	F_y (ksi)	F_u (ksi)
1	29000	50	65

Section Dimensions

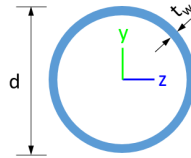

ID	Name	d (in)	t_w (in)				
3	2in Pipe Sch 120	2.38	0.25				
6	4in Pipe Sch 120	4.50	0.44				
11	10in Pipe Sch 40	10.75	0.36				

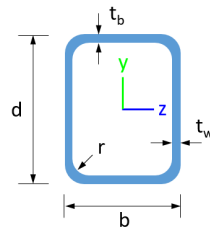

ID	Name	d (in)	b (in)	t_w (in)	t_b (in)	r (in)	
17	HSS5x3x1/4	5.00	3.00	0.23	0.23	0.23	

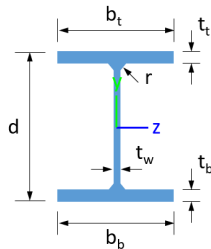

ID	Name	d (in)	t_w (in)	b_t (in)	b_b (in)	t_t (in)	t_b (in)	r (in)
20	W10x12	9.87	0.19	3.96	3.96	0.21	0.21	0.30

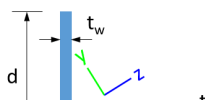

Member Design Capacity

Member ID	$\Phi_t P_n$ (kip)	$\Phi_c P_n$ (kip)	$\Phi_b M_{zn}$ (k-ft)	$\Phi_b M_{yn}$ (k-ft)	$\Phi_v V_{yn}$ (kip)	$\Phi_v V_{zn}$ (kip)
1	535.87	349.02	147.68	147.68	160.76	160.76
2	251.01	248.88	27.16	27.16	75.30	75.30
3	151.65	150.70	20.17	14.14	54.12	28.95
4	151.65	145.15	20.17	14.14	54.12	28.95
5	151.65	149.10	20.17	14.14	54.12	28.95
6	151.65	150.70	20.17	14.14	54.12	28.95
7	151.65	149.10	20.17	14.14	54.12	28.95
8	159.30	68.92	46.90	6.46	56.26	44.91
9	75.10	66.32	4.25	4.25	22.53	22.53
10	151.65	145.15	20.17	14.14	54.12	28.95
11	159.30	68.92	46.90	6.46	56.26	44.91
12	251.01	248.88	27.16	27.16	75.30	75.30
13	159.30	97.43	31.06	6.46	56.26	44.91
14	159.30	97.43	31.05	6.46	56.26	44.91
15	159.30	68.92	46.90	6.46	56.26	44.91
16	159.30	68.92	46.90	6.46	56.26	44.91
50	41.27	8.45	1.63	0.76	15.23	10.15
51	41.27	8.45	1.63	0.76	15.23	10.15
52	41.27	8.45	1.63	0.76	15.23	10.15
53	41.27	8.45	1.63	0.76	15.23	10.15

Design Ratio

Member ID	P	M _z	M _y	V _y	V _z	(P,M _z ,M _y)	Worst LC	KL/r	δ	Status
1	0.036	0.870	0.000	0.070	0.000	0.887	#13	0.383	Not Required	Pass
2	0.005	0.368	0.393	0.079	0.075	0.762	#13	0.054	Not Required	Pass
3	0.001	0.745	0.098	0.074	0.041	0.806	#13	0.046	Not Required	Pass
4	0.001	0.741	0.030	0.074	0.002	0.760	#13	0.082	Not Required	Pass
5	0.001	0.463	0.024	0.074	0.009	0.476	#13	0.076	Not Required	Pass
6	0.001	0.745	0.098	0.074	0.041	0.806	#13	0.046	Not Required	Pass
7	0.001	0.463	0.024	0.074	0.009	0.477	#13	0.076	Not Required	Pass
8	0.017	0.193	0.176	0.046	0.012	0.237	#21	0.535	Not Required	Pass
9	0.020	0.053	0.076	0.001	0.000	0.135	#13	0.137	Not Required	Pass
10	0.001	0.741	0.030	0.074	0.002	0.760	#13	0.082	Not Required	Pass
11	0.008	0.194	0.176	0.046	0.012	0.232	#21	0.357	Not Required	Pass
12	0.005	0.369	0.393	0.079	0.075	0.762	#13	0.054	Not Required	Pass
13	0.008	0.474	0.034	0.058	0.006	0.487	#13	0.204	Not Required	Pass
14	0.013	0.477	0.024	0.057	0.006	0.485	#13	0.306	Not Required	Pass
15	0.008	0.194	0.176	0.046	0.012	0.232	#21	0.357	Not Required	Pass
16	0.017	0.193	0.176	0.046	0.012	0.237	#21	0.357	Not Required	Pass
50	0.193	0.009	0.007	0.002	0.001	0.206	#21	0.783	Not Required	Pass
51	0.039	0.003	0.016	0.001	0.001	0.054	#21	0.522	Not Required	Pass
52	0.193	0.009	0.007	0.002	0.001	0.206	#23	0.783	Not Required	Pass
53	0.039	0.003	0.017	0.001	0.001	0.054	#23	0.522	Not Required	Pass

Definitions

Φ_t Safety factor for tensile

Φ_c	Safety factor for compression
Φ_b	Safety factor for flexure
Φ_v	Safety factor for shear
E	Modulus of elasticity
F_y	Specified minimum yield stress
F_u	Specified minimum tensile strength
A	Cross-sectional area
J	Torsional constant
I_{yp}	Moment of inertia about the Y axes
I_{zp}	Moment of inertia about the Z axes
I_w	Warping constant
S_{yp}	Plastic section modulus about the Y axis
S_{zp}	Plastic section modulus about the Z axis
KL	Effective length
C_b	Buckling modification factor (from all load combinations)
L_b	Length between braced points
LST	Limited slenderness for tension
LSC	Limited slenderness for compression
LD	Limited deflection
P_n	Nominal axial strength (tension/compression)
M_n	Nominal flexural strength (about Z/Y axis)
V_n	Nominal shear strength (along Z/Y axis)
P	Design ratio in case of axial force
M_z	Design ratio in case of bending about Z axis
M_y	Design ratio in case of bending about Y axis
V_y	Design ratio in case of shear along Y axis
V_z	Design ratio in case of shear along Z axis
(P, M_z, M_y)	Design ratio in case of axial force and bending action
KL/r	Design ratio in case of section slenderness
δ	Design ratio in case of member deflection
OK	Capacity is provided
NG	Capacity is not provided

REFERENCES	CALCULATIONS	RESULTS
------------	--------------	---------

SkyCiv Foundation Design

Pile Foundation

Design Information :

Design code : IBC 2021 (International Building Code)
Unit System : Imperial

Pile Input

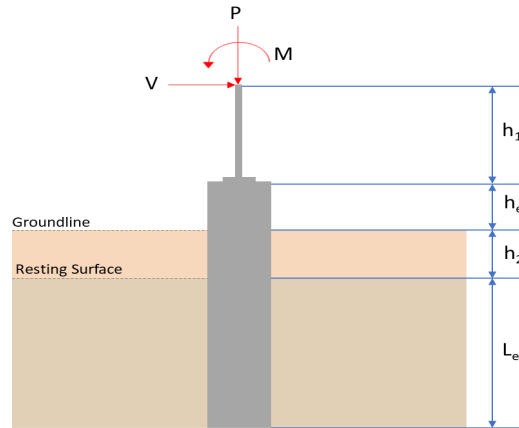

Geometry

Pile shape: rectangular

$b = 48$ in - Pile width

$D = 48$ in - Pile depth

$L = 8.5$ ft - Total pile length

$h_1 = 0$ ft - Lateral load height from the top of the pile,

$h_2 = 0$ ft - Depth to resisting surface

$h_e = 0$ ft - Length of pile above the ground

Tabulation of Soil Parameters

Layer	Label	Allowable Bearing Pressure (q_a) (psf)	Allowable Lateral Pressure (R) (psf/ft)
1	Sand, silty sand, clayey sand, silty gravel & clayey gravel	2000.000	150.000

Tabulation of Loads

Load Component	ASD	LRFD
P (kip)	8.026	12.415
V_x (kip)	-6.782	-11.304
V_z (kip)	0.000	0.000
M_x (kipft)	0.000	-0.002
M_z (kipft)	76.522	128.427

Material Properties

$f'_{ck} = 2.5$ ksi - Concrete strength.

Required depth to resist lateral loads (ASD)

H - Point of application of the lateral load

$$H = h_1 + h_2 + h_e$$

$$H = (0 \text{ ft}) + (0 \text{ ft}) + (0 \text{ ft})$$

$$H = 0 \text{ ft}$$

Considering x-direction:

H_o - Lateral force per length of pile,

$$H_o = \frac{V_x}{1.57 D}$$

$$H_o = \frac{(-6.782 \text{ kip})}{1.57 \times (48 \text{ in})}$$

$$H_o = -1.0799 \text{ kip/ft}$$

M_o - Moment per length of pile,

$$M_o = \frac{M_z + (V_x H)}{1.57 D}$$

$$M_o = \frac{(76.522 \text{ kipft}) + ((-6.782 \text{ kip}) \times (0 \text{ ft}))}{1.57 \times (48 \text{ in})}$$

$$M_o = 12.185 \text{ kipft/ft}$$

Required depth of embedment in earth:

$$L_x^3 - \left(14.14 \times \frac{H_o \times L_x}{R}\right) - \left(18.85 \times \frac{M_o}{R}\right) = 0$$

Solving the cubic equation:

$L_{e,x} = 7.7791 \text{ ft}$ - Required depth in x-direction,

Considering z-direction:

$L_{e,z} = 0 \text{ ft}$ - Required depth in z-direction,

Minimum embedded depth required:

$L_{e,req}$ - Depth of pile required,

$$L_{e,req} = \text{MAX}[L_{e,x}, L_{e,z}]$$

$$L_{e,req} = \text{MAX}[(7.7791 \text{ ft}), (0 \text{ ft})]$$

$$L_{e,req} = 7.779 \text{ ft}$$

L_e - Actual embedded length of pile,

$$L_e = L - h_e - h_2$$

$$L_e = (8.5 \text{ ft}) - (0 \text{ ft}) - (0 \text{ ft})$$

$$L_e = 8.5 \text{ ft}$$

Ratio - Embedded depth

$$\text{Ratio} = \frac{L_{e,req}}{L_e}$$

$$\text{Ratio} = \frac{(7.779 \text{ ft})}{(8.5 \text{ ft})}$$

$$\text{Ratio} = 0.91518$$

Status: **PASS**
Ratio: **0.920**

End-bearing Capacity (ASD)

A - Pile cross-section area

$$A = b D$$

$$A = (48 \text{ in}) \times (48 \text{ in})$$

$$A = 16 \text{ ft}^2$$

q - End-bearing pressure

$$q = \frac{P_v}{A}$$

$$q = \frac{(8.026 \text{ kip})}{(16 \text{ ft}^2)}$$

$$q = 0.50162 \text{ kip/ft}^2$$

Check bearing capacity ratio:

Ratio - Capacity

$$\text{Ratio} = \frac{q}{q_a}$$

$$\text{Ratio} = \frac{(0.50162 \text{ kip/ft}^2)}{(2000 \text{ psf})}$$

$$\text{Ratio} = 0.25081$$

Status: **PASS**
Ratio: **0.250**

Czerniak

Lateral Soil Pressure (ASD):

L/D - Length to least lateral dimension ratio,

$$L/D = \frac{L}{D}$$

$$L/D = \frac{(8.5 \text{ ft})}{(48 \text{ in})}$$

$$L/D = 2.125$$

Since $L/D \leq 10$,

Pile is short.

Considering x-direction:

$H_o = -1.0799 \text{ kip/ft}$ - Lateral force per length of pile,

$M_o = 12.185 \text{ kipft/ft}$ - Overturning moment per length of pile,

a - Distance from resting surface to pivot point,

$$a = \frac{(4 M_o L_e) + (3 H_o L_e^2)}{(6 M_o) + (4 H_o L_e)}$$

$$a = \frac{(4 \times (12.185 \text{ kipft/ft}) \times (8.5 \text{ ft})) + (3 \times (-1.0799 \text{ kip/ft}) \times (8.5 \text{ ft})^2)}{(6 \times (12.185 \text{ kipft/ft})) + (4 \times (-1.0799 \text{ kip/ft}) \times (8.5 \text{ ft}))}$$

$$a = 5.9035 \text{ ft}$$

p - Earth pressure against the pile at distance $a/2$ from resting surface,

$$p = \frac{0.75 [(4 M_o) + (3 H_o L_e)]^2}{L_e^2 [(3 M_o) + (2 H_o L_e)]}$$

$$p = \frac{0.75 \times [(4 \times (12.185 \text{ kipft/ft})) + (3 \times (-1.0799 \text{ kip/ft}) \times (8.5 \text{ ft}))]^2}{(8.5 \text{ ft})^2 \times [(3 \times (12.185 \text{ kipft/ft})) + (2 \times (-1.0799 \text{ kip/ft}) \times (8.5 \text{ ft}))]}$$

$$p = 0.25644 \text{ kip/ft}^2$$

s - Earth pressure against the pile at distance L_e ,

$$s = \frac{6 [(2 M_o) + (H_o L_e)]}{L_e^2}$$

$$s = \frac{6 \times [(2 \times (12.185 \text{ kipft/ft})) + ((-1.0799 \text{ kip/ft}) \times (8.5 \text{ ft}))]}{(8.5 \text{ ft})^2}$$

$$s = 1.2615 \text{ kip/ft}^2$$

Check lateral soil pressure capacity:

p_a - Allowable lateral soil pressure at depth $a/2$,

$$p_a = R \frac{a}{2}$$

$$p_a = (150 \text{ psf/ft}) \times \frac{(5.9035 \text{ ft})}{2}$$

$$p_a = 0.44276 \text{ kip/ft}^2$$

Ratio - Lateral soil capacity

$$\text{Ratio} = \frac{p}{p_a}$$

$$\text{Ratio} = \frac{(0.25644 \text{ kip/ft}^2)}{(0.44276 \text{ kip/ft}^2)}$$

$$\text{Ratio} = 0.57919$$

p_s - Allowable lateral soil pressure at depth L_e ,

$$p_s = R L_e$$

$$p_s = (150 \text{ psf/ft}) \times (8.5 \text{ ft})$$

$$p_s = 1.275 \text{ kip/ft}^2$$

Ratio - Lateral soil capacity

$$\text{Ratio} = \frac{s}{p_s}$$

$$\text{Ratio} = \frac{(1.2615 \text{ kip/ft}^2)}{(1.275 \text{ kip/ft}^2)}$$

Status: **PASS**
Ratio: **0.580**



Shear force and Bending moment (x-direction, LRFD)

H_o - Lateral force per length of pile,

$$H_o = \frac{V_x}{1.57 D}$$

$$H_o = \frac{(-11.304 \text{ kip})}{1.57 \times (48 \text{ in})}$$

$$H_o = -1.8 \text{ kip/ft}$$

M_o - Moment per length of pile,

$$M_o = \frac{M_z + (V_x H)}{1.57 D}$$

$$M_o = \frac{(128.43 \text{ kipft}) + ((-11.304 \text{ kip}) \times (0 \text{ ft}))}{1.57 \times (48 \text{ in})}$$

$$M_o = 20.45 \text{ kipft/ft}$$

E - Distance from lateral load to resisting surface,

$$E = \frac{M_o}{H_o}$$

$$E = \frac{(20.45 \text{ kipft/ft})}{(-1.8 \text{ kip/ft})}$$

$$E = 11.361 \text{ ft}$$

a - Distance from resting surface to pivot point,

$$a = \frac{(4 M_o L_c) + (3 H_o L_c^2)}{(6 M_o) + (4 H_o L_c)}$$

$$a = \frac{(4 \times (20.45 \text{ kipft/ft}) \times (8.5 \text{ ft})) + (3 \times (-1.8 \text{ kip/ft}) \times (8.5 \text{ ft})^2)}{(6 \times (20.45 \text{ kipft/ft})) + (4 \times (-1.8 \text{ kip/ft}) \times (8.5 \text{ ft}))}$$

$$a = 5.9024 \text{ ft}$$

V_{max} - Max shear force located at depth a ,

$$V_{max} = (H_o D) \left[1 - \left[3 \left(\frac{4E}{L_c} + 3 \right) \left(\frac{a}{L_c} \right)^2 \right] + \left[4 \left(\frac{3E}{L_c} + 2 \right) \left(\frac{a}{L_c} \right)^3 \right] \right]$$

$$V_{max} = ((-1.8 \text{ kip/ft}) \times (48 \text{ in})) \times \left[1 - \left[3 \times \left(\frac{4 \times (11.361 \text{ ft})}{(8.5 \text{ ft})} + 3 \right) \times \left(\frac{(5.9024 \text{ ft})}{(8.5 \text{ ft})} \right)^2 \right] + \left[4 \times \left(\frac{3 \times (11.361 \text{ ft})}{(8.5 \text{ ft})} + 2 \right) \times \left(\frac{(5.9024 \text{ ft})}{(8.5 \text{ ft})} \right)^3 \right] \right]$$

$$V_{max} = 21.111 \text{ kip}$$

M_{max} - Max bending moment located at depth $a/2$,

$$M_{max} = (H_o D L_e) \left[\left(\frac{E}{L_e} + \frac{a}{2 L_e} \right) - \left[\left(\frac{4E}{L_e} + 3 \right) \left(\frac{a}{2 L_e} \right)^3 + \left[\left(\frac{3E}{L_e} + 2 \right) \left(\frac{a}{2 L_e} \right)^4 \right] \right]$$

$$M_{max} = ((-1.8 \text{ kip/ft}) \times (48 \text{ in}) \times (8.5 \text{ ft})) \times \left[\left(\frac{(11.361 \text{ ft})}{(8.5 \text{ ft})} + \frac{(5.9024 \text{ ft})}{2 \times (8.5 \text{ ft})} \right) - \left[\left(\frac{4 \times (11.361 \text{ ft})}{(8.5 \text{ ft})} + 3 \right) \times \left(\frac{(5.9024 \text{ ft})}{2 \times (8.5 \text{ ft})} \right)^3 + \left[\left(\frac{3 \times (11.361 \text{ ft})}{(8.5 \text{ ft})} + 2 \right) \times \left(\frac{(5.9024 \text{ ft})}{2 \times (8.5 \text{ ft})} \right)^4 \right] \right]$$

$$M_{max} = 87.015 \text{ kipft}$$

Shear force and Bending moment (z-direction, LRFD)

H_o - Lateral force per length of pile,

$$H_o = \frac{V_z}{1.57 b}$$

$$H_o = \frac{(0 \text{ kip})}{1.57 \times (48 \text{ in})}$$

$$H_o = 0 \text{ kip/ft}$$

M_o - Moment per length of pile,

$$M_o = \frac{M_x + (V_z H)}{1.57 b}$$

$$M_o = \frac{(0.002 \text{ kipft}) + ((0 \text{ kip}) \times (0 \text{ ft}))}{1.57 \times (48 \text{ in})}$$

$$M_o = 0.00031847 \text{ kipft/ft}$$

a - Distance from resting surface to pivot point,

$$a = \frac{(4 M_o L_e) + (3 H_o L_e^2)}{(6 M_o) + (4 H_o L_e)}$$

$$a = \frac{(4 \times (0.00031847 \text{ kipft/ft}) \times (8.5 \text{ ft})) + (3 \times (0 \text{ kip/ft}) \times (8.5 \text{ ft})^2)}{(6 \times (0.00031847 \text{ kipft/ft})) + (4 \times (0 \text{ kip/ft}) \times (8.5 \text{ ft}))}$$

$$a = 5.6667 \text{ ft}$$

V_{max} - Max shear force located at depth a ,

$$V_{max} = 12 \left(\frac{M_o b}{L_e} \right) \left(\frac{a}{L_e} - 1 \right) \left(\frac{a}{L_e} \right)^2$$

$$V_{max} = 12 \times \left(\frac{(0.00031847 \text{ kipft/ft}) \times (48 \text{ in})}{(8.5 \text{ ft})} \right) \times \left(\frac{(5.6667 \text{ ft})}{(8.5 \text{ ft})} - 1 \right) \times \left(\frac{(5.6667 \text{ ft})}{(8.5 \text{ ft})} \right)^2$$

$$V_{max} = 0.00026643 \text{ kip}$$

M_{max} - Max bending moment at depth $a/2$,

$$M_{max} = (M_o b) \left[1 - \left(4 \frac{a}{2 L_e} \right)^3 + \left(3 \frac{a}{2 L_e} \right)^4 \right]$$

$$M_{max} = ((0.00031847 \text{ kipft/ft}) \times (48 \text{ in})) \times \left[1 - \left(4 \times \frac{(5.6667 \text{ ft})}{2 \times (8.5 \text{ ft})} \right)^3 + \left(3 \times \frac{(5.6667 \text{ ft})}{2 \times (8.5 \text{ ft})} \right)^4 \right]$$

$$M_{max} = 0.0011323 \text{ kipft}$$

Minimum Reinforcement Check (LRFD)

Parameters:

$f'_{ck} = 2.5 \text{ ksi}$ - Concrete strength,
 $f_{yk} = 60 \text{ ksi}$ - Longitudinal reinforcement strength,
 $\phi = 0.65$ - Reduction factor for axial strength,
 $\alpha = 0.8$ - Alpha factor for axial strength,
 $A_g = 2304 \text{ in}^2$ - Gross area of concrete,

Longitudinal reinforcement:

Required reinforcement due to axial load, $A_{st,required}$

$A_{st,required}$

Table 22.4.2.1

22.4.2.2, 10.6.1.1

$$A_{st,required} = Min \left[\frac{\frac{V'}{\phi \alpha} - (0.85 f'_{ck} A_g)}{f_{yk} - (0.85 f'_{ck})}, (0.08 A_g) \right]$$

$$A_{st,required} = Min \left[\frac{\left(\frac{12.415 \text{ kip}}{(0.65) \times (0.8)} \right) - (0.85 \times (2.5 \text{ ksi}) \times (2304 \text{ in}^2))}{(60 \text{ ksi}) - (0.85 \times (2.5 \text{ ksi}))}, (0.08 \times (2304 \text{ in}^2)) \right]$$

$$A_{st,required} = -84.184 \text{ in}^2$$

A_{min} - Governing minimum reinforcement area,

$$A_{min} = Max [A_{st,required}, (0.0018 A_g)]$$

$$A_{min} = Max [(-84.184 \text{ in}^2), (0.0018 \times (2304 \text{ in}^2))]$$

$$A_{min} = 4.1472 \text{ in}^2$$

n_{rebar} - Required number of reinforcement,

$$n_{rebar} = \frac{A_{min}}{A_{rebar}}$$

$$n_{rebar} = \frac{(4.1472 \text{ in}^2)}{(0.3068 \text{ in}^2)}$$

$$n_{rebar} = 14$$

A_{st} - Actual total reinforcement area,

$$A_{st} = n_{rebar} \frac{\pi d_{bar}^2}{4}$$

$$A_{st} = (14) \times \frac{\pi \times (0.625 \text{ in})^2}{4}$$

$$A_{st} = 4.2951 \text{ in}^2$$

Ratio - Capacity

$$Ratio = \frac{A_{min}}{A_{st}}$$

$$Ratio = \frac{(4.1472 \text{ in}^2)}{(4.2951 \text{ in}^2)}$$

$$Ratio = 0.96556$$

Status: **PASS**
Ratio: **0.970**

25.2.3 s_{rebar} - Minimum spacing of reinforcement,

$$s_{rebar} = Max [1.5, (1.5 d_{bar})]$$

$$s_{rebar} = Max [1.5, (1.5 \times (0.625 \text{ in}))]$$

$$s_{rebar} = 1.5 \text{ in}$$

Ties:

25.7.2.2 Since longitudinal reinforcement is \leq No. 10 \emptyset : Use #3(0.375 in)

25.7.2.1 s_{ties} - Maximum spacing of ties,

$$s_{ties} = Min [(16 d_{bar}), (48 d_{ties}), Min (D, b)]$$

$$s_{ties} = Min [(16 \times (0.625 \text{ in})), (48 \times (0.375 \text{ in})), Min ((48 \text{ in}), (48 \text{ in}))]$$

$$s_{ties} = 10 \text{ in}$$

Summary:

Main reinforcement: **14 - #5 (0.625 in)**

Ties: **#3(0.375 in) - 10 in**

22.4.2.2 **Axial Compression Strength (ACI 318-19, LFRD)**

ϕP_N - Allowable axial compressive strength

$$\phi P_N = \phi 0.80 [(0.85 f'_{ck} [A_g - A_{st}]) + (f_{yk} A_{st})]$$

$$\phi P_N = (0.65) \times 0.80 \times [(0.85 \times (2.5 \text{ ksi}) \times [(2304 \text{ in}^2) - (4.2951 \text{ in}^2)]) + ((60 \text{ ksi}) \times (4.2951 \text{ in}^2))]$$

$$\phi P_N = 2675.2 \text{ kip}$$

Ratio - Capacity

$$Ratio = \frac{P}{\phi P_N}$$

$$Ratio = \frac{(12.415 \text{ kip})}{(2675.2 \text{ kip})}$$

$$Ratio = 0.0046408$$

Status: **PASS**
Ratio: **0.000**

Shear Strength (ACI 318-19, LRFD)

Parameters:

$b_w = 48$ in - Effective width,
 d - Effective depth

$$d = 0.80 D$$

$$d = 0.80 \times (48 \text{ in})$$

$$d = 38.4 \text{ in}$$

22.5.5.1.3 λ_s - size effect modification factor

$$\lambda_s = MIN \left[\sqrt{\frac{2}{1 + \frac{d}{10}}}, 1 \right]$$

$$\lambda_s = MIN \left[\sqrt{\frac{2}{1 + \frac{(38.4 \text{ in})}{10}}}, 1 \right]$$

$$\lambda_s = 0.64282$$

The following variables were converted to be consistent with empirical formula $f'_{ck} = 2.5 \text{ ksi} \rightarrow 2500 \text{ psi}$,

22.5.5.1.1 $V_{c,max}$ - Max shear strength of concrete

$$V_{c,max} = 5 \lambda_s \sqrt{f'_{ck}} b_w d$$

$$V_{c,max} = 5 \times (0.64282) \times \sqrt{(2500 \text{ psi})} \times (48 \text{ in}) \times (38.4 \text{ in})$$

$$V_{c,max} = 296.21 \text{ kip}$$

The following variables were converted to be consistent with empirical formula $f'_{ck} = 2.5 \text{ ksi} \rightarrow 2500 \text{ psi}$, $P = 12.415 \text{ kip} \rightarrow 12415 \text{ lbf}$,

22.5.5.1.1(a) $V_{c,a}$ - Shear strength of concrete (a)

$$V_{c,a} = \left[2 \lambda_s \sqrt{f'_{ck}} + \frac{P}{6 A_g} \right] b_w d$$

$$V_{c,a} = \left[2 \times (0.64282) \times \sqrt{(2500 \text{ psi})} + \frac{(12415 \text{ lbf})}{6 \times (2304 \text{ in}^2)} \right] \times (48 \text{ in}) \times (38.4 \text{ in})$$

$$V_{c,a} = 120.14 \text{ kip}$$

The following variables were converted to be consistent with empirical formula $f'_{ck} = 2.5 \text{ ksi} \rightarrow 2500 \text{ psi}$,

22.5.5.1.2 $V_{c,b}$ - Shear strength of concrete (b)

$$V_{c,b} = \left[2 \lambda_s \sqrt{f'_{ck}} + (0.05 f'_{ck}) \right] b_w d$$

$$V_{c,b} = \left[2 \times (0.64282) \times \sqrt{(2500 \text{ psi})} + (0.05 \times (2500 \text{ psi})) \right] \times (48 \text{ in}) \times (38.4 \text{ in})$$

$$V_{c,b} = 348.89 \text{ kip}$$

V_c - Governing shear strength of concrete

$$V_c = MIN [V_{c,max}, V_{c,a}, V_{c,b}]$$

$$V_c = MIN [(296.21 \text{ kip}), (120.14 \text{ kip}), (348.89 \text{ kip})]$$

$$V_c = 120.14 \text{ kip}$$

The following variables were converted to be consistent with empirical formula $f'_{ck} = 2.5 \text{ ksi} \rightarrow 2500 \text{ psi}$,

22.5.1.2 $V_{s,a}$ - Shear strength of steel (a)

$$V_{s,a} = 8 \sqrt{f'_{ck}} b_w d$$

$$V_{s,a} = 8 \times \sqrt{(2500 \text{ psi})} \times (48 \text{ in}) \times (38.4 \text{ in})$$

	<p style="text-align: center;">$V_{s,a} = 737.28 \text{ kip}$</p> <p>$A_v$ - Ties rebar area,</p> $A_v = \frac{\pi d_{ties}^2}{4}$ $A_v = \frac{\pi \times (0.375 \text{ in})^2}{4}$ $A_v = 0.11045 \text{ in}^2$ <p>22.5.8.5.3 $V_{s,b}$ - Shear strength of steel (b)</p> $V_{s,b} = \frac{2 A_v f_{yw} d}{s_{ties}}$ $V_{s,b} = \frac{2 \times (0.11045 \text{ in}^2) \times (60 \text{ ksi}) \times (38.4 \text{ in})}{(10 \text{ in})}$ $V_{s,b} = 50.894 \text{ kip}$ <p>V_s - Governing shear strength of steel</p> $V_s = MIN[V_{s,a}, V_{s,b}]$ $V_s = MIN[(737.28 \text{ kip}), (50.894 \text{ kip})]$ $V_s = 50.894 \text{ kip}$ <p>22.5.1.1 ϕV_n - Allowable shear strength</p> $\phi V_n = \phi (V_c + V_s)$ $\phi V_n = (0.65) \times ((120.14 \text{ kip}) + (50.894 \text{ kip}))$ $\phi V_n = 111.17 \text{ kip}$ <p>Considering x-direction:</p> <p>$V_{max} = 21.777 \text{ kip}$ - Maximum shear force in the x-direction, Ratio - Capacity</p> $Ratio = \frac{V_{max}}{\phi V_n}$ $Ratio = \frac{(21.777 \text{ kip})}{(111.17 \text{ kip})}$ $Ratio = 0.19588$	<p>Status: PASS Ratio: 0.200</p>
<p>14.5.2.1b</p>	<p>Flexural Strength (ACI 318-19, LRFD)</p> <p>S_m - Section modulus</p> $S_m = \frac{b D^2}{6}$ $S_m = \frac{(48 \text{ in}) \times (48 \text{ in})^2}{6}$ $S_m = 18432 \text{ in}^3$ <p>$\lambda = 1$ - Concrete modification factor (Normal concrete), Allowable flexural strength: M_n shall be the lesser of: $\phi M_{n,1}$</p> $\phi M_{n,1} = \phi \times 5 \times \lambda \times \sqrt{f'_c} \times S_m$ $\phi M_{n,1} = 0.65 \times 5 \times 1 \times \sqrt{(2.5 \text{ ksi})} \times 18432.001 \text{ in}^3$ $\phi M_{n,1} = 249.600 \text{ kipft}$ <p>$\phi M_{n,2}$</p> $\phi M_{n,2} = \phi \times 0.85 f'_c S_m$ $\phi M_{n,2} = (0.65) \times 0.85 \times (2.5 \text{ ksi}) \times (18432 \text{ in}^3)$ $\phi M_{n,2} = 2121.6 \text{ kipft}$	

Therefore,
 ϕM_n - Allowable flexural strength,

$$\phi M_n = \text{MIN}[\phi M_{n,1}, \phi M_{n,2}]$$

$$\phi M_n = \text{MIN}[(249.6 \text{ kipft}), (2121.6 \text{ kipft})]$$

$$\phi M_n = 249.6 \text{ kipft}$$

Considering x-direction:

$M_{max} = 87.015 \text{ kipft}$ - Maximum moment in the x-direction,
Ratio - Capacity

$$\text{Ratio} = \frac{M_{max}}{\phi M_n}$$

$$\text{Ratio} = \frac{(87.015 \text{ kipft})}{(249.6 \text{ kipft})}$$

$$\text{Ratio} = 0.34862$$

Status: **PASS**
Ratio: **0.350**

Considering z-direction:

$M_{max} = 0.0011323 \text{ kipft}$ - Maximum moment in the z-direction,
Ratio - Capacity

$$\text{Ratio} = \frac{M_{max}}{\phi M_n}$$

$$\text{Ratio} = \frac{(0.0011323 \text{ kipft})}{(249.6 \text{ kipft})}$$

$$\text{Ratio} = 4.5366 \times 10^{-6}$$

Status: **PASS**
Ratio: **0.000**