

Your Project Calculations



Project Name: HorseCanyon590CWL-JB-RevB

S3D Model Link:
https://platform.skyciv.com/structural?preload_name=HorseCanyon590CWL-JB-RevB&preload_path=Shared%20Enterprise%20Folder/MT_Solar_Projects/5_2023

Public Model Link:
https://platform.skyciv.com/structural-viewer?project_id=nUyTozvm0RVRMbRO8slQS360YQj31hpXSuiRGeLojA6vQuwjdkpddBbwc5syoidW

Array Specification

Product:	Beam
Unique ID:	3P-17-8TOP-HD-45-L-5Hx7W-J31F
Duty Classification:	HD
Module Width:	41.50 in
Module Length:	84.00in
Number of Rows:	5
Number of Columns:	7
Total Number of Modules:	35
Desired Tilt Angle:	45
Front Edge Clearance:	4
Total Array Height at Tilt:	16.30 ft
Total Frame Length:	49.00 ft
Frame Weight:	2496 lbs
Array Dimensions N/S:	17.50 ft
Array Dimensions E/W:	49.58 ft
Rail Length:	210.00 in
Rail Spacing:	3.50 ft
Rail Check:	

Support Specifications

Pole Size:	8in Pipe Sch 40
Pole Length above Grade:	10.19 ft
Number of Poles:	3
Pole Spacing:	17 ft

Foundation Specifications

Foundation Type:	Square
Foundation Dimensions:	48 x 48 in
Foundation Depth (below grade):	Pile 1: 7.00 ft Pile 2: 7.00 ft Pile 3: 7.00 ft
Foundation Volume:	12.444 y ³
Foundation Result:	PASSED
Mount Twist:	0.145550 kip

Site Info

Risk Category:	I
Exposure:	C
Soil Classification:	sand
Site Location:	927 Main St, Carlin, NV 89822, USA
Wind Speed:	94 mph
Snow Load:	26 psf
Design Uplift Pressure:	Multiple pressures
Design Downforce Pressure:	Multiple pressures
Design Snow Pressure:	0.007148 ksf



Design Disclaimer

This software should be used for preliminary designs and should not be used as a final design unless reviewed, verified and designed by a qualified structural engineer.

AutoDesigner Input

```
{
  "wind_speed_override": 94,
  "snow_load_override": 26,
  "direct_snow_load": false,
  "product_type": "Beam",
  "project_id": "HorseCanyon590CWL-JB-RevB",
  "site_address": "927 Main St, Carlin, NV 89822, USA",
  "module_width": 41.5,
  "module_length": 84,
  "number_rows": 5,
  "number_columns": 7,
  "pole_mount_section": "4_40",
  "core_pipe_width": 65,
  "core_pipe_section": "2_40",
  "adjuster_section": "2_40",
  "core_beam_height": 65,
  "core_beam_section": "HSS3x2x1/8",
  "main_pipe_section": "2_12GA",
  "pole_spacing": 15,
  "tilt_angle": 45,
  "ground_clearance": 4,
  "risk_category": "I",
  "exposure_category": "C",
  "frame_duty_override": "auto",
  "pole_override": "auto",
  "soil_type": "sand",
  "foundation_type": "Square",
  "foundation_size": 48,
  "check_rails": true
}
```

Design Notes:

- AISC Deflection checks are set to L/1 due to structure design intent
- Foundation Design and Sizing is approximate only

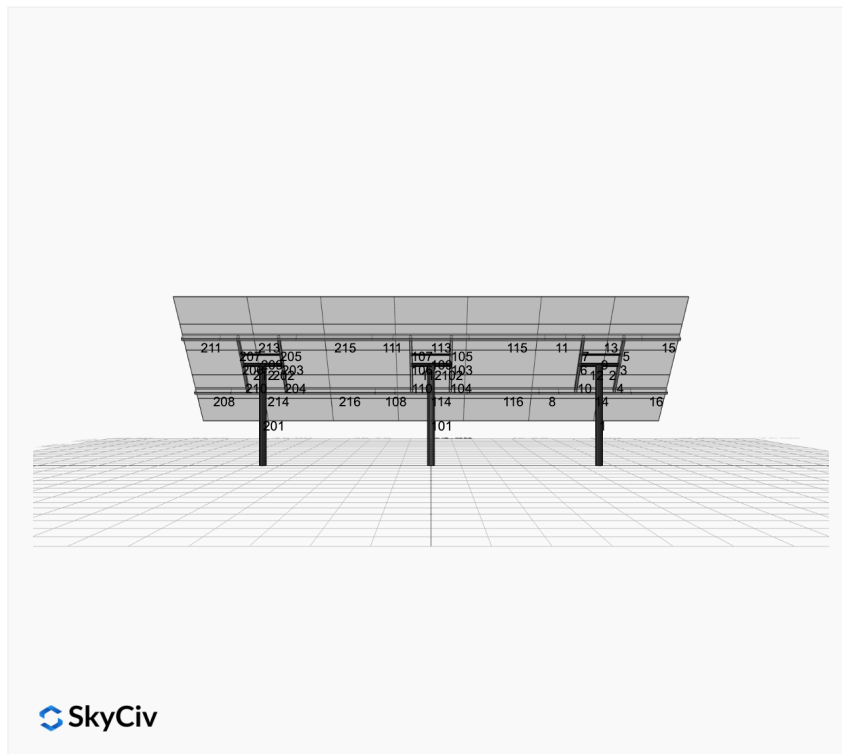

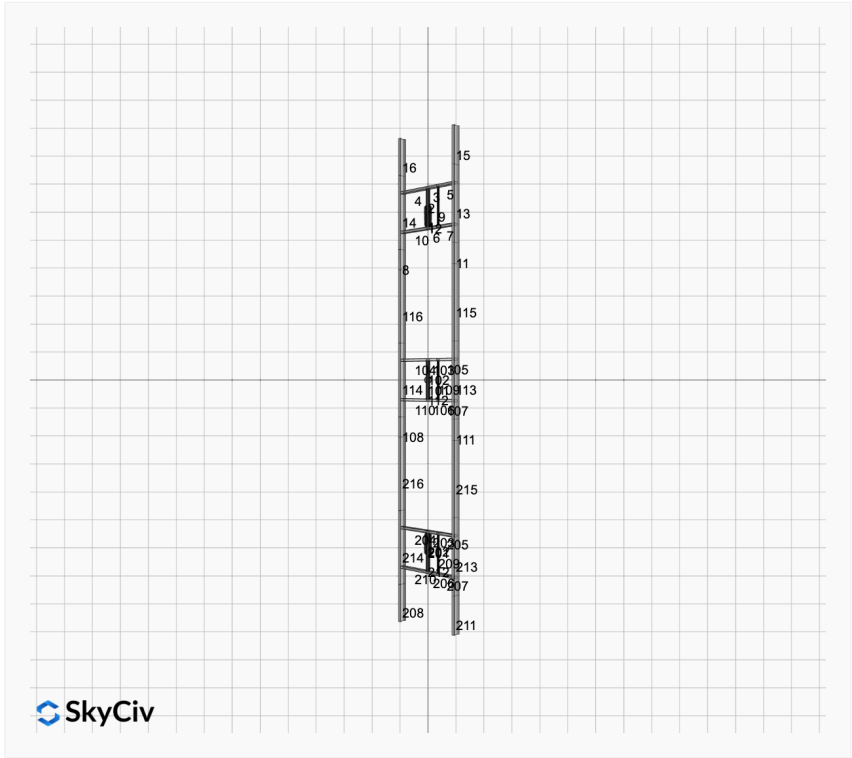
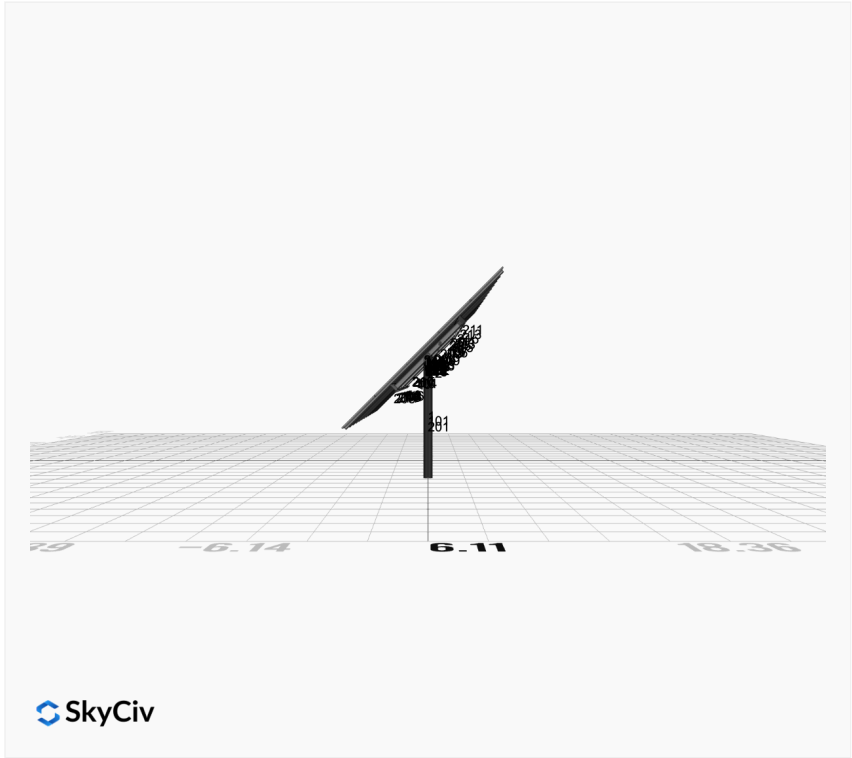

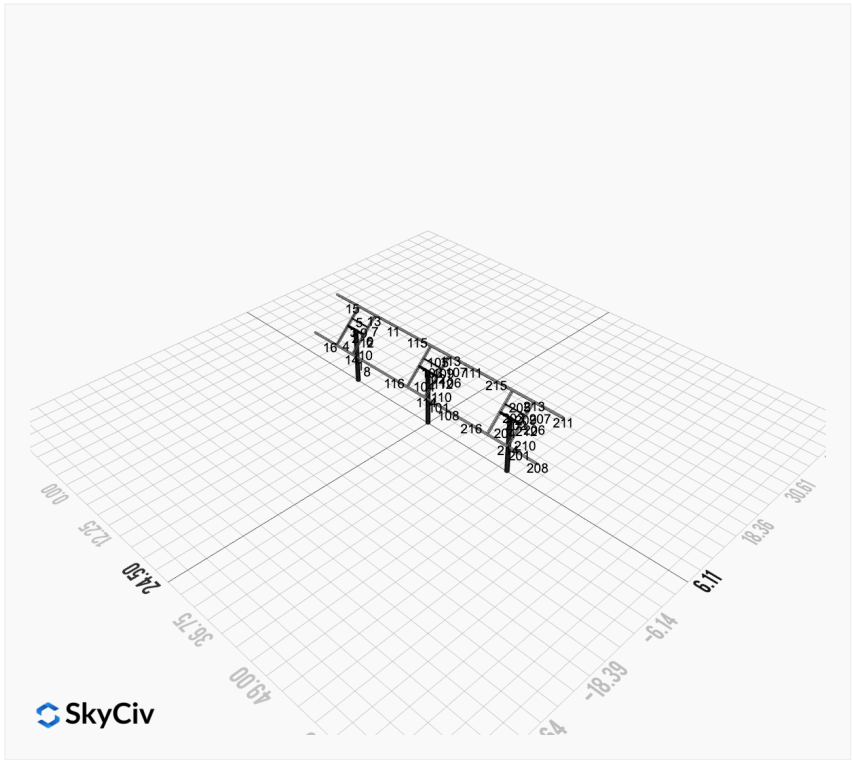

FEM Results (Envelope Worst Case for each member)

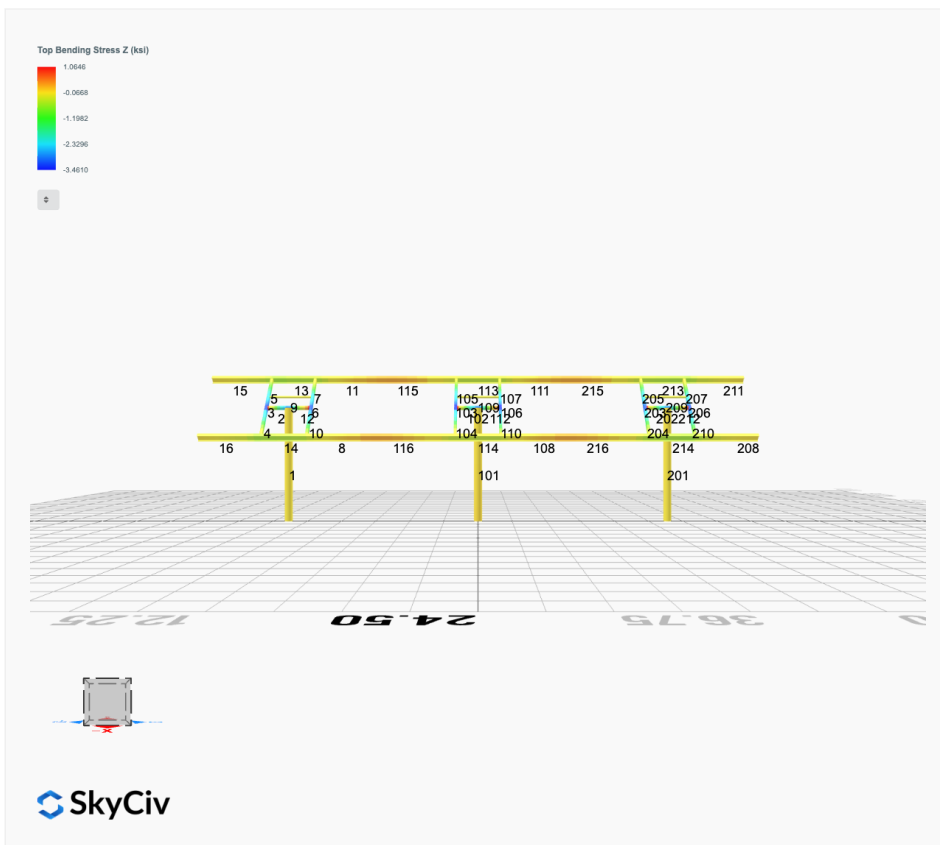
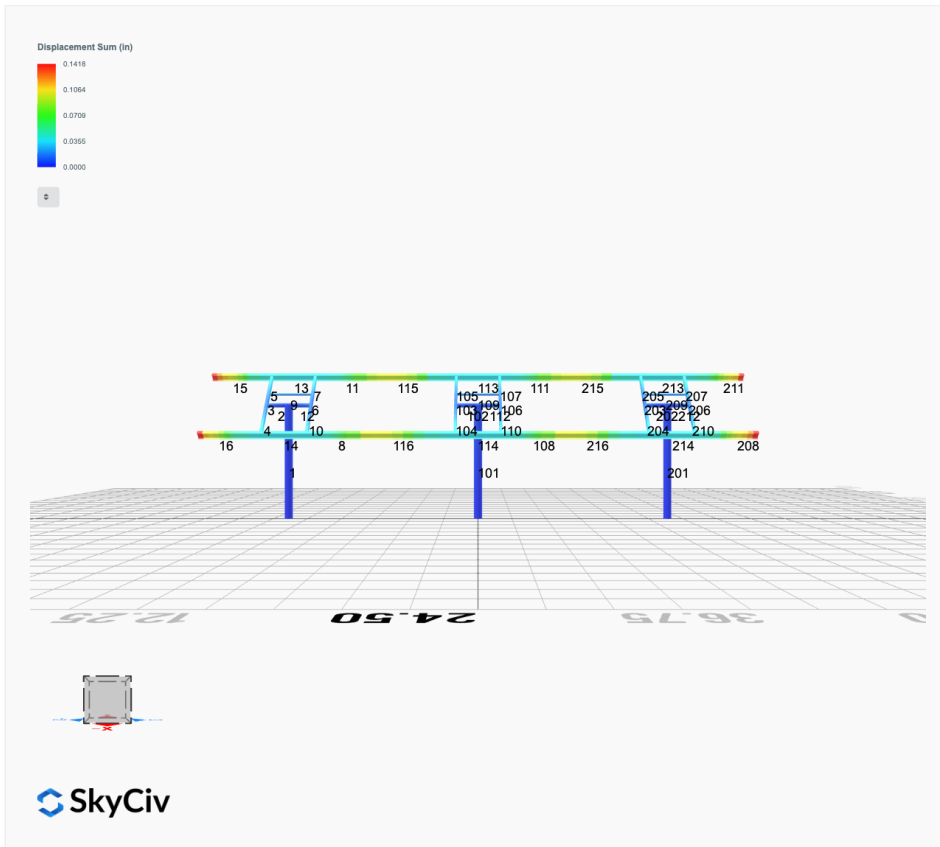

Top Bending Stress Y (ksi)

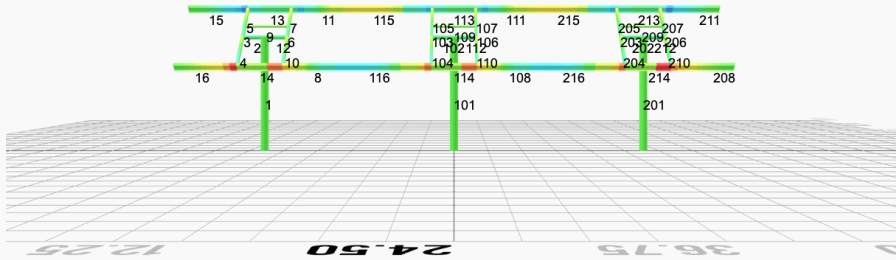

Shear Stress Y (ksi)

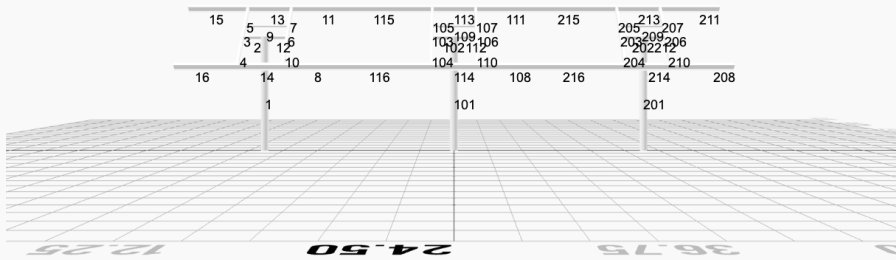

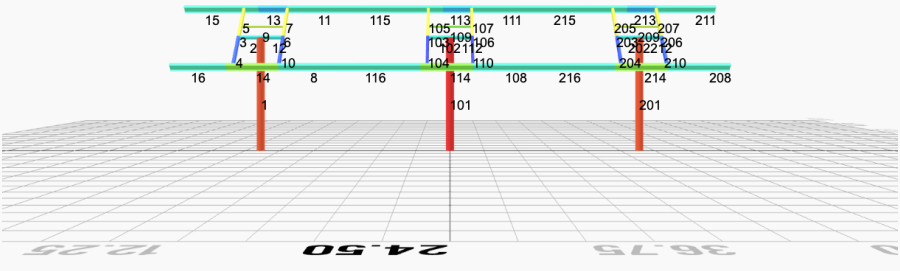

SkyCiv

Reaction Forces for Foundation 1 (Node ID#1), (kip, kip-ft)

ASD Load Combination Results

Name	Fx	Fy	Fz	Mx	My	Mz
ULS: 1. D	-0.0067	2.1036	-0.0034	-0.0072	0.0413	0.0826
ULS: 2. D + L	-0.0067	2.1036	-0.0034	-0.0072	0.0413	0.0826
ULS: 3. D + (S or Lr or R)	-0.0125	3.5256	-0.0063	-0.0131	0.0775	0.1380
ULS: 3. D + (S or Lr or R)	-0.0067	2.1036	-0.0034	-0.0072	0.0413	0.0826
ULS: 4. D + 0.75L + 0.75(S or Lr or R)	-0.0111	3.1701	-0.0056	-0.0116	0.0685	0.1241
ULS: 4. D + 0.75L + 0.75(S or Lr or R)	-0.0067	2.1036	-0.0034	-0.0072	0.0413	0.0826
ULS: 5b. D + 0.7E	-0.0067	2.1036	-0.0034	-0.0072	0.0413	0.0826
ULS: 6b. D + 0.75L + 0.75(0.7)E + 0.75S	-0.0111	3.1701	-0.0056	-0.0116	0.0685	0.1241
ULS: 8. 0.6D + 0.7E	-0.0040	1.2622	-0.0020	-0.0043	0.0248	0.0496
ULS: 5a. D + 0.6W_Wind downforce Case A only	-3.3372	5.4287	-0.0162	-0.0421	0.0871	35.6353
ULS: 5a. D + 0.6W_Wind downforce Case B only	-3.3372	5.4287	-0.0162	-0.0421	0.0871	35.6353
ULS: 5a. D + 0.6W_Wind uplift Case A only	2.4017	-0.3013	0.0064	0.0194	0.0057	-23.4971
ULS: 5a. D + 0.6W_Wind uplift Case B only	2.1209	-0.0197	0.0038	0.0124	0.0167	-27.3562
ULS: 6a. D + 0.75L + 0.75(0.6)W + 0.75(S or Lr or R)_Wind downforce Case A only	-2.5090	5.6640	-0.0152	-0.0378	0.1029	26.7887
ULS: 6a. D + 0.75L + 0.75(0.6)W + 0.75(S or Lr or R)_Wind downforce Case B only	-2.5090	5.6640	-0.0152	-0.0378	0.1029	26.7887
ULS: 6a. D + 0.75L + 0.75(0.6)W + 0.75(S or Lr or R)_Wind uplift Case A only	1.7952	1.3664	0.0018	0.0083	0.0417	-17.5606
ULS: 6a. D + 0.75L + 0.75(0.6)W + 0.75(S or Lr or R)_Wind uplift Case B only	1.5846	1.5777	-0.0002	0.0030	0.0500	-20.4549
ULS: 6a. D + 0.75L + 0.75(0.6)W + 0.75(S or Lr or R)_Wind downforce Case A only	-2.5046	4.5974	-0.0130	-0.0334	0.0757	26.7471
ULS: 6a. D + 0.75L + 0.75(0.6)W + 0.75(S or Lr or R)_Wind downforce Case B only	-2.5046	4.5974	-0.0130	-0.0334	0.0757	26.7471
ULS: 6a. D + 0.75L + 0.75(0.6)W + 0.75(S or Lr or R)_Wind uplift Case A only	1.7996	0.2999	0.0040	0.0127	0.0146	-17.6022
ULS: 6a. D + 0.75L + 0.75(0.6)W + 0.75(S or Lr or R)_Wind uplift Case B only	1.5890	0.5111	0.0020	0.0075	0.0228	-20.4965
ULS: 7. 0.6D + 0.6W_Wind downforce Case A only	-3.3345	4.5873	-0.0149	-0.0392	0.0706	35.6022
ULS: 7. 0.6D + 0.6W_Wind downforce Case B only	-3.3345	4.5873	-0.0149	-0.0392	0.0706	35.6022
ULS: 7. 0.6D + 0.6W_Wind uplift Case A only	2.4044	-1.1428	0.0078	0.0222	-0.0109	-23.5301
ULS: 7. 0.6D + 0.6W_Wind uplift Case B only	2.1235	-0.8611	0.0051	0.0152	0.0001	-27.3892

Worst Case Reactions LRFD

These calculations are taken directly from the FEA via SkyCiv and are used in the Concrete Checks of the Foundation Module.
Note: Worst case values are assumed as downforce wind load cases.

Result	Value (kip, kip-ft)
Axial	8.7774
Shear X	-5.5621
Shear Z	-0.0268
Moment X	-0.0695
Moment Y (Twist)	0.1456
Moment Z	59.9084

Worst Case Reactions ASD

These results are taken from the worst case values in the above table and are used in the Soil Checks in the Foundation Module.
Note: Worst case values are assumed as downforce wind load cases.

Result	Value (kip, kip-ft)
Axial	5.6640
Shear X	-3.3372
Shear Z	-0.0162
Moment X	-0.0421
Moment Y (Twist)	0.1029
Moment Z	35.6353

Reaction Forces for Foundation 2 (Node ID#101), (kip, kip-ft)

ASD Load Combination Results

Name	Fx	Fy	Fz	Mx	My	Mz
ULS: 1. D	0.0134	2.1796	-0.0000	0.0000	0.0000	-0.0976
ULS: 2. D + L	0.0134	2.1796	-0.0000	0.0000	0.0000	-0.0976
ULS: 3. D + (S or Lr or R)	0.0251	3.6694	-0.0000	0.0000	0.0000	-0.2003
ULS: 3. D + (S or Lr or R)	0.0134	2.1796	-0.0000	0.0000	0.0000	-0.0976
ULS: 4. D + 0.75L + 0.75(S or Lr or R)	0.0222	3.2969	-0.0000	0.0000	0.0000	-0.1746
ULS: 4. D + 0.75L + 0.75(S or Lr or R)	0.0134	2.1796	-0.0000	0.0000	0.0000	-0.0976
ULS: 5b. D + 0.7E	0.0134	2.1796	-0.0000	0.0000	0.0000	-0.0976

Name	Fx	Fy	Fz	Mx	My	Mz
ULS: 6b. D + 0.75L + 0.75(0.7)E + 0.75S	0.0222	3.2969	-0.0000	0.0000	0.0000	-0.1746
ULS: 8. 0.6D + 0.7E	0.0080	1.3077	-0.0000	0.0000	0.0000	-0.0585
ULS: 5a. D + 0.6W_Wind downforce Case A only	-3.3760	5.5797	-0.0000	0.0000	0.0000	36.0299
ULS: 5a. D + 0.6W_Wind downforce Case B only	-3.3760	5.5797	-0.0000	0.0000	0.0000	36.0299
ULS: 5a. D + 0.6W_Wind uplift Case A only	2.4671	-0.2811	-0.0000	0.0000	0.0000	-24.0673
ULS: 5a. D + 0.6W_Wind uplift Case B only	2.1734	0.0110	-0.0000	0.0000	0.0000	-27.9433
ULS: 6a. D + 0.75L + 0.75(0.6)W + 0.75(S or Lr or R)_Wind downforce Case A only	-2.5199	5.8471	-0.0000	0.0000	0.0000	26.9210
ULS: 6a. D + 0.75L + 0.75(0.6)W + 0.75(S or Lr or R)_Wind downforce Case B only	-2.5199	5.8471	-0.0000	0.0000	0.0000	26.9210
ULS: 6a. D + 0.75L + 0.75(0.6)W + 0.75(S or Lr or R)_Wind uplift Case A only	1.8624	1.4514	-0.0000	0.0000	0.0000	-18.1519
ULS: 6a. D + 0.75L + 0.75(0.6)W + 0.75(S or Lr or R)_Wind uplift Case B only	1.6422	1.6705	-0.0000	0.0000	0.0000	-21.0589
ULS: 6a. D + 0.75L + 0.75(0.6)W + 0.75(S or Lr or R)_Wind downforce Case A only	-2.5287	4.7297	-0.0000	0.0000	0.0000	26.9980
ULS: 6a. D + 0.75L + 0.75(0.6)W + 0.75(S or Lr or R)_Wind downforce Case B only	-2.5287	4.7297	-0.0000	0.0000	0.0000	26.9980
ULS: 6a. D + 0.75L + 0.75(0.6)W + 0.75(S or Lr or R)_Wind uplift Case A only	1.8536	0.3341	-0.0000	0.0000	0.0000	-18.0749
ULS: 6a. D + 0.75L + 0.75(0.6)W + 0.75(S or Lr or R)_Wind uplift Case B only	1.6334	0.5531	-0.0000	0.0000	0.0000	-20.9819
ULS: 7. 0.6D + 0.6W_Wind downforce Case A only	-3.3814	4.7079	-0.0000	0.0000	0.0000	36.0689
ULS: 7. 0.6D + 0.6W_Wind downforce Case B only	-3.3814	4.7079	-0.0000	0.0000	0.0000	36.0689
ULS: 7. 0.6D + 0.6W_Wind uplift Case A only	2.4617	-1.1529	-0.0000	0.0000	0.0000	-24.0283
ULS: 7. 0.6D + 0.6W_Wind uplift Case B only	2.1681	-0.8609	-0.0000	0.0000	0.0000	-27.9043

Worst Case Reactions LRFD

These calculations are taken directly from the FEA via SkyCiv and are used in the Concrete Checks of the Foundation Module.
Note: Worst case values are assumed as downforce wind load cases.

Result	Value (kip, kip-ft)
Axial	9.0270
Shear X	-5.6490
Shear Z	-0.0000
Moment X	0.0001
Moment Y (Twist)	0.0002
Moment Z	60.5826

Worst Case Reactions ASD

These results are taken from the worst case values in the above table and are used in the Soil Checks in the Foundation Module.
Note: Worst case values are assumed as downforce wind load cases.

Result	Value (kip, kip-ft)
Axial	5.8471
Shear X	-3.3814
Shear Z	-0.0000
Moment X	0.0000
Moment Y (Twist)	0.0000
Moment Z	36.0689

Reaction Forces for Foundation 3 (Node ID#201), (kip, kip-ft)

ASD Load Combination Results

Name	Fx	Fy	Fz	Mx	My	Mz
ULS: 1. D	-0.0067	2.1036	0.0034	0.0072	-0.0413	0.0826
ULS: 2. D + L	-0.0067	2.1036	0.0034	0.0072	-0.0413	0.0826
ULS: 3. D + (S or Lr or R)	-0.0125	3.5256	0.0063	0.0131	-0.0775	0.1380
ULS: 3. D + (S or Lr or R)	-0.0067	2.1036	0.0034	0.0072	-0.0413	0.0826
ULS: 4. D + 0.75L + 0.75(S or Lr or R)	-0.0111	3.1701	0.0056	0.0116	-0.0685	0.1242
ULS: 4. D + 0.75L + 0.75(S or Lr or R)	-0.0067	2.1036	0.0034	0.0072	-0.0413	0.0826
ULS: 5b. D + 0.7E	-0.0067	2.1036	0.0034	0.0072	-0.0413	0.0826
ULS: 6b. D + 0.75L + 0.75(0.7)E + 0.75S	-0.0111	3.1701	0.0056	0.0116	-0.0685	0.1242
ULS: 8. 0.6D + 0.7E	-0.0040	1.2622	0.0020	0.0043	-0.0248	0.0496
ULS: 5a. D + 0.6W_Wind downforce Case A only	-3.3372	5.4287	0.0162	0.0421	-0.0871	35.6353
ULS: 5a. D + 0.6W_Wind downforce Case B only	-3.3372	5.4287	0.0162	0.0421	-0.0871	35.6353
ULS: 5a. D + 0.6W_Wind uplift Case A only	2.4017	-0.3013	-0.0064	-0.0194	-0.0057	-23.4971
ULS: 5a. D + 0.6W_Wind uplift Case B only	2.1209	-0.0197	-0.0038	-0.0124	-0.0167	-27.3562
ULS: 6a. D + 0.75L + 0.75(0.6)W + 0.75(S or Lr or R)_Wind downforce Case A only	-2.5090	5.6640	0.0152	0.0378	-0.1029	26.7887
ULS: 6a. D + 0.75L + 0.75(0.6)W + 0.75(S or Lr or R)_Wind downforce Case B only	-2.5090	5.6640	0.0152	0.0378	-0.1029	26.7887
ULS: 6a. D + 0.75L + 0.75(0.6)W + 0.75(S or Lr or R)_Wind uplift Case A only	1.7952	1.3664	-0.0018	-0.0083	-0.0417	-17.5606
ULS: 6a. D + 0.75L + 0.75(0.6)W + 0.75(S or Lr or R)_Wind uplift Case B only	1.5846	1.5777	0.0002	-0.0030	-0.0500	-20.4549

Name	Fx	Fy	Fz	Mx	My	Mz
ULS: 6a. D + 0.75L + 0.75(0.6)W + 0.75(S or Lr or R)_Wind downforce Case A only	-2.5046	4.5974	0.0130	0.0334	-0.0757	26.7471
ULS: 6a. D + 0.75L + 0.75(0.6)W + 0.75(S or Lr or R)_Wind downforce Case B only	-2.5046	4.5974	0.0130	0.0334	-0.0757	26.7471
ULS: 6a. D + 0.75L + 0.75(0.6)W + 0.75(S or Lr or R)_Wind uplift Case A only	1.7996	0.2999	-0.0040	-0.0127	-0.0146	-17.6022
ULS: 6a. D + 0.75L + 0.75(0.6)W + 0.75(S or Lr or R)_Wind uplift Case B only	1.5890	0.5111	-0.0020	-0.0075	-0.0228	-20.4965
ULS: 7. 0.6D + 0.6W_Wind downforce Case A only	-3.3345	4.5873	0.0149	0.0392	-0.0706	35.6022
ULS: 7. 0.6D + 0.6W_Wind downforce Case B only	-3.3345	4.5873	0.0149	0.0392	-0.0706	35.6022
ULS: 7. 0.6D + 0.6W_Wind uplift Case A only	2.4044	-1.1428	-0.0078	-0.0222	0.0109	-23.5301
ULS: 7. 0.6D + 0.6W_Wind uplift Case B only	2.1235	-0.8611	-0.0051	-0.0152	-0.0001	-27.3892

Worst Case Reactions LRFD

These calculations are taken directly from the FEA via SkyCiv and are used in the Concrete Checks of the Foundation Module.
Note: Worst case values are assumed as downforce wind load cases.

Result	Value (kip, kip-ft)
Axial	8.7774
Shear X	-5.5621
Shear Z	0.0268
Moment X	0.0695
Moment Y (Twist)	0.1456
Moment Z	59.9094

Worst Case Reactions ASD

These results are taken from the worst case values in the above table and are used in the Soil Checks in the Foundation Module.
Note: Worst case values are assumed as downforce wind load cases.

Result	Value (kip, kip-ft)
Axial	5.6640
Shear X	-3.3372
Shear Z	0.0162
Moment X	0.0421
Moment Y (Twist)	0.1029
Moment Z	35.6353

Project Details

Design Code: AISC 360-16 LRFD
 Provision: LRFD
 Country: United States

User Name: sales@mtsolar.us
 Project Name: HorseCanyon590CWL-JB-RevB
 Unit System: imperial



Design Input Information

Design Factors			
Φ_t	Φ_c	Φ_b	Φ_v
0.9	0.9	0.9	0.9

Design Materials			
ID	E (ksi)	F _y (ksi)	F _u (ksi)
1	29000	50	65

Section Dimensions							

ID	Name	d (in)	t _w (in)				
2	2in Pipe Sch 80	2.38	0.22				
5	4in Pipe Sch 80	4.50	0.34				
9	8in Pipe Sch 40	8.63	0.32				

ID	Name	d (in)	b (in)	t _w (in)	t _b (in)	r (in)	
16	HSS5x3x3/16	5.00	3.00	0.17	0.17	0.17	

ID	Name	d (in)	t _w (in)	b _t (in)	b _b (in)	t _t (in)	t _b (in)	r (in)
19	W8x10	7.89	0.17	3.94	3.94	0.20	0.20	0.30

Section Properties								
ID	Name	A (in ²)	J (in ⁴)	I _{yp} (in ⁴)	I _{zp} (in ⁴)	I _w (in ⁶)	S _{yp} (in ³)	S _{zp} (in ³)
2	2in Pipe Sch 80	1.48	1.74	0.87	0.87	0.00	1.02	1.02
5	4in Pipe Sch 80	4.41	19.22	9.61	9.61	0.00	5.85	5.85

Member Design Capacity

Member ID	$\Phi_t P_n$ (kip)	$\Phi_c P_n$ (kip)	$\Phi_b M_{zn}$ (k-ft)	$\Phi_b M_{yn}$ (k-ft)	$\Phi_v V_{yn}$ (kip)	$\Phi_v V_{zn}$ (kip)
1	377.97	216.26	83.29	83.29	113.39	113.39
2	198.33	196.72	21.95	21.95	59.50	59.50
3	116.10	115.41	15.79	11.10	42.08	23.28
4	116.10	111.33	15.79	11.10	42.08	23.28
5	116.10	114.23	15.79	11.10	42.08	23.28
6	116.10	115.41	15.79	11.10	42.08	23.28
7	116.10	114.23	15.79	11.10	42.08	23.28
8	133.20	126.01	32.87	6.12	40.24	43.62
9	66.48	58.89	3.82	3.82	19.94	19.94
10	116.10	111.33	15.79	11.10	42.08	23.28
11	133.20	126.01	32.87	6.12	40.24	43.62
12	198.33	196.72	21.95	21.95	59.50	59.50
13	133.20	104.94	25.44	6.12	40.24	43.62
14	133.20	104.94	24.52	6.12	40.24	43.62
15	133.20	52.83	32.87	6.12	40.24	43.62
16	133.20	52.83	32.87	6.12	40.24	43.62
101	377.97	216.26	83.29	83.29	113.39	113.39
102	198.33	196.72	21.95	21.95	59.50	59.50
103	116.10	115.41	15.79	11.10	42.08	23.28
104	116.10	111.33	15.79	11.10	42.08	23.28
105	116.10	114.23	15.79	11.10	42.08	23.28
106	116.10	115.41	15.79	11.10	42.08	23.28
107	116.10	114.23	15.79	11.10	42.08	23.28
108	133.20	126.01	32.87	6.12	40.24	43.62
109	66.48	58.89	3.82	3.82	19.94	19.94
110	116.10	111.33	15.79	11.10	42.08	23.28
111	133.20	126.01	32.87	6.12	40.24	43.62
112	198.33	196.72	21.95	21.95	59.50	59.50
113	133.20	104.94	23.60	6.12	40.24	43.62
114	133.20	104.94	23.14	6.12	40.24	43.62
115	133.20	93.89	24.87	6.12	40.24	43.62
116	133.20	93.89	24.87	6.12	40.24	43.62
201	377.97	216.26	83.29	83.29	113.39	113.39
202	198.33	196.72	21.95	21.95	59.50	59.50
203	116.10	115.41	15.79	11.10	42.08	23.28
204	116.10	111.33	15.79	11.10	42.08	23.28
205	116.10	114.23	15.79	11.10	42.08	23.28
206	116.10	115.41	15.79	11.10	42.08	23.28
207	116.10	114.23	15.79	11.10	42.08	23.28
208	133.20	52.83	32.87	6.12	40.24	43.62
209	66.48	58.89	3.82	3.82	19.94	19.94
210	116.10	111.33	15.79	11.10	42.08	23.28
211	133.20	52.83	32.87	6.12	40.24	43.62
212	198.33	196.72	21.95	21.95	59.50	59.50
213	133.20	104.94	25.44	6.12	40.24	43.62
214	133.20	104.94	24.75	6.12	40.24	43.62
215	133.20	93.89	26.71	6.12	40.24	43.62
216	133.20	93.89	26.02	6.12	40.24	43.62

Design Ratio

Member ID	P	M _z	M _y	V _y	V _z	(P,M _z ,M _y)	Worst LC	KL/r	δ	Status
1	0.041	0.719	0.002	0.049	0.000	0.740	#13	0.437	Not Required	Pass
2	0.001	0.326	0.246	0.071	0.047	0.573	#13	0.035	Not Required	Pass
3	0.007	0.619	0.045	0.062	0.010	0.651	#13	0.045	Not Required	Pass
4	0.007	0.557	0.090	0.056	0.019	0.596	#13	0.080	Not Required	Pass
5	0.006	0.384	0.092	0.062	0.022	0.396	#13	0.074	Not Required	Pass
6	0.007	0.610	0.047	0.061	0.009	0.642	#13	0.045	Not Required	Pass
7	0.007	0.379	0.090	0.061	0.023	0.393	#13	0.074	Not Required	Pass
8	0.000	0.052	0.061	0.035	0.010	0.099	#21	0.095	Not Required	Pass
9	0.005	0.045	0.047	0.001	0.000	0.094	#13	0.204	Not Required	Pass
10	0.007	0.547	0.088	0.055	0.020	0.592	#13	0.080	Not Required	Pass
11	0.000	0.057	0.061	0.039	0.010	0.100	#21	0.095	Not Required	Pass
12	0.001	0.317	0.239	0.070	0.046	0.557	#13	0.035	Not Required	Pass
13	0.004	0.200	0.228	0.053	0.014	0.358	#21	0.286	Not Required	Pass
14	0.004	0.185	0.228	0.047	0.014	0.349	#21	0.190	Not Required	Pass
15	0.000	0.067	0.106	0.029	0.008	0.153	#21	Not Required	Not Required	Pass
16	0.000	0.061	0.106	0.026	0.008	0.150	#21	Not Required	Not Required	Pass
101	0.042	0.727	0.000	0.050	0.000	0.748	#13	0.437	Not Required	Pass
102	0.001	0.328	0.243	0.073	0.047	0.571	#13	0.035	Not Required	Pass
103	0.007	0.627	0.051	0.063	0.012	0.663	#13	0.045	Not Required	Pass
104	0.007	0.566	0.083	0.057	0.019	0.609	#13	0.080	Not Required	Pass
105	0.007	0.389	0.085	0.062	0.021	0.402	#13	0.074	Not Required	Pass
106	0.007	0.627	0.051	0.063	0.012	0.663	#13	0.045	Not Required	Pass
107	0.007	0.389	0.085	0.062	0.021	0.402	#13	0.074	Not Required	Pass
108	0.000	0.061	0.062	0.032	0.010	0.105	#21	0.095	Not Required	Pass
109	0.003	0.040	0.044	0.001	0.000	0.085	#13	0.204	Not Required	Pass
110	0.007	0.566	0.083	0.057	0.019	0.609	#13	0.080	Not Required	Pass
111	0.000	0.069	0.062	0.035	0.010	0.107	#21	0.095	Not Required	Pass
112	0.001	0.328	0.243	0.073	0.047	0.571	#13	0.035	Not Required	Pass
113	0.004	0.142	0.204	0.049	0.014	0.293	#21	0.286	Not Required	Pass
114	0.004	0.136	0.203	0.045	0.014	0.286	#21	0.286	Not Required	Pass
115	0.000	0.124	0.115	0.035	0.010	0.202	#21	0.346	Not Required	Pass
116	0.000	0.112	0.116	0.032	0.010	0.197	#21	0.346	Not Required	Pass
201	0.041	0.719	0.002	0.049	0.000	0.740	#13	0.437	Not Required	Pass
202	0.001	0.317	0.239	0.070	0.046	0.557	#13	0.035	Not Required	Pass
203	0.007	0.610	0.047	0.061	0.010	0.642	#13	0.045	Not Required	Pass
204	0.007	0.547	0.088	0.055	0.020	0.592	#13	0.080	Not Required	Pass
205	0.007	0.379	0.090	0.061	0.023	0.393	#13	0.074	Not Required	Pass
206	0.007	0.619	0.045	0.062	0.010	0.651	#13	0.045	Not Required	Pass
207	0.006	0.384	0.092	0.062	0.022	0.396	#13	0.074	Not Required	Pass
208	0.000	0.061	0.106	0.026	0.008	0.150	#21	Not Required	Not Required	Pass
209	0.005	0.045	0.047	0.001	0.000	0.094	#13	0.204	Not Required	Pass
210	0.007	0.557	0.090	0.056	0.019	0.596	#13	0.080	Not Required	Pass
211	0.000	0.067	0.106	0.029	0.008	0.153	#21	Not Required	Not Required	Pass
212	0.001	0.326	0.246	0.071	0.047	0.573	#13	0.035	Not Required	Pass
213	0.004	0.200	0.228	0.053	0.014	0.358	#21	0.190	Not Required	Pass
214	0.004	0.185	0.228	0.047	0.014	0.349	#21	0.286	Not Required	Pass
215	0.000	0.120	0.115	0.039	0.010	0.199	#21	0.346	Not Required	Pass
216	0.000	0.108	0.116	0.035	0.010	0.194	#21	0.346	Not Required	Pass

Definitions

Φ_t	Safety factor for tensile
Φ_c	Safety factor for compression
Φ_b	Safety factor for flexure
Φ_v	Safety factor for shear
E	Modulus of elasticity
F_y	Specified minimum yield stress
F_u	Specified minimum tensile strength
A	Cross-sectional area
J	Torsional constant
I_{yp}	Moment of inertia about the Y axes
I_{zp}	Moment of inertia about the Z axes
I_w	Warping constant
S_{yp}	Plastic section modulus about the Y axis
S_{zp}	Plastic section modulus about the Z axis
KL	Effective length
C_b	Buckling modification factor (from all load combinations)
L_b	Length between braced points
LST	Limited slenderness for tension
LSC	Limited slenderness for compression
LD	Limited deflection
P_n	Nominal axial strength (tension/compression)
M_n	Nominal flexural strength (about Z/Y axis)
V_n	Nominal shear strength (along Z/Y axis)
P	Design ratio in case of axial force
M_z	Design ratio in case of bending about Z axis
M_y	Design ratio in case of bending about Y axis
V_y	Design ratio in case of shear along Y axis
V_z	Design ratio in case of shear along Z axis
(P, M_z, M_y)	Design ratio in case of axial force and bending action
KL/r	Design ratio in case of section slenderness
δ	Design ratio in case of member deflection
OK	Capacity is provided
NG	Capacity is not provided

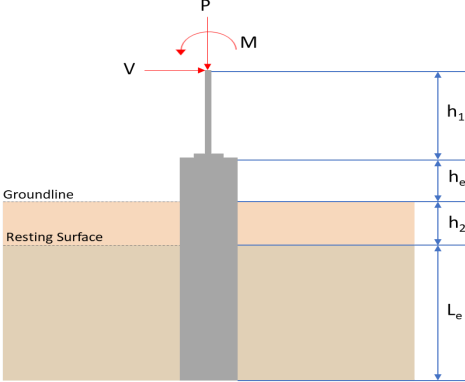
REFERENCES	CALCULATIONS	RESULTS																										
	<p>SkyCiv Foundation Design Pile Foundation</p> <p>Design Information : Design code : IBC 2021 (International Building Code) Unit System : Imperial</p>																											
	<p>Pile Input</p>  <p>Geometry Pile shape: rectangular $b = 48$ in - Pile width $D = 48$ in - Pile depth $L = 7$ ft - Total pile length $h_1 = 0$ ft - Lateral load height from the top of the pile, $h_2 = 0$ ft - Depth to resting surface $h_e = 0$ ft - Length of pile above the ground</p> <p>Tabulation of Soil Parameters</p> <table border="1" data-bbox="416 1102 1193 1193"> <thead> <tr> <th>Layer</th> <th>Label</th> <th>Allowable Bearing Pressure (q_a) (psf)</th> <th>Allowable Lateral Pressure (R) (psf/ft)</th> </tr> </thead> <tbody> <tr> <td>1</td> <td>Sand, silty sand, clayey sand, silty gravel & clayey gravel</td> <td>2000.000</td> <td>150.000</td> </tr> </tbody> </table> <p>Tabulation of Loads</p> <table border="1" data-bbox="676 1288 935 1458"> <thead> <tr> <th>Load Component</th> <th>ASD</th> <th>LRFD</th> </tr> </thead> <tbody> <tr> <td>P (kip)</td> <td>5.664</td> <td>8.777</td> </tr> <tr> <td>V_x (kip)</td> <td>-3.337</td> <td>-5.562</td> </tr> <tr> <td>V_z (kip)</td> <td>-0.016</td> <td>-0.027</td> </tr> <tr> <td>M_x (kipft)</td> <td>-0.042</td> <td>-0.069</td> </tr> <tr> <td>M_z (kipft)</td> <td>35.635</td> <td>59.908</td> </tr> </tbody> </table> <p>Material Properties $f'_{ck} = 3$ ksi - Concrete strength,</p>	Layer	Label	Allowable Bearing Pressure (q_a) (psf)	Allowable Lateral Pressure (R) (psf/ft)	1	Sand, silty sand, clayey sand, silty gravel & clayey gravel	2000.000	150.000	Load Component	ASD	LRFD	P (kip)	5.664	8.777	V_x (kip)	-3.337	-5.562	V_z (kip)	-0.016	-0.027	M_x (kipft)	-0.042	-0.069	M_z (kipft)	35.635	59.908	
Layer	Label	Allowable Bearing Pressure (q_a) (psf)	Allowable Lateral Pressure (R) (psf/ft)																									
1	Sand, silty sand, clayey sand, silty gravel & clayey gravel	2000.000	150.000																									
Load Component	ASD	LRFD																										
P (kip)	5.664	8.777																										
V_x (kip)	-3.337	-5.562																										
V_z (kip)	-0.016	-0.027																										
M_x (kipft)	-0.042	-0.069																										
M_z (kipft)	35.635	59.908																										
	<p>Required depth to resist lateral loads (ASD) H - Point of application of the lateral load</p> $H = h_1 + h_2 + h_e$ $H = (0 \text{ ft}) + (0 \text{ ft}) + (0 \text{ ft})$ $H = 0 \text{ ft}$ <p>Considering x-direction: H_o - Lateral force per length of pile,</p> $H_o = \frac{V_x}{1.57 D}$ $H_o = \frac{(-3.337 \text{ kip})}{1.57 \times (48 \text{ in})}$ $H_o = -0.53137 \text{ kip/ft}$ <p>M_o - Moment per length of pile,</p> $M_o = \frac{M_z + (V_x H)}{1.57 D}$																											

$$M_o = \frac{(35.635 \text{ kipft}) + ((-3.337 \text{ kip}) \times (0 \text{ ft}))}{1.57 \times (48 \text{ in})}$$

$$M_o = 5.6744 \text{ kipft/ft}$$

Required depth of embedment in earth:

$$L_x^3 - \left(14.14 \times \frac{H_o \times L_x}{R}\right) - \left(18.85 \times \frac{M_o}{R}\right) = 0$$

Solving the cubic equation:

$L_{e,x} = 6.3201 \text{ ft}$ - Required depth in x-direction,

Considering z-direction:

H_o - Lateral force per length of pile,

$$H_o = \frac{V_z}{1.57 b}$$

$$H_o = \frac{(-0.016 \text{ kip})}{1.57 \times (48 \text{ in})}$$

$$H_o = -0.0025478 \text{ kip/ft}$$

M_o - Moment per length of pile,

$$M_o = \frac{M_x + (V_z H)}{1.57 b}$$

$$M_o = \frac{(0.042 \text{ kipft}) + ((-0.016 \text{ kip}) \times (0 \text{ ft}))}{1.57 \times (48 \text{ in})}$$

$$M_o = 0.0066879 \text{ kipft/ft}$$

Required depth of embedment in earth:

$$L_z^3 - \left(14.14 \times \frac{H_o \times L_z}{R}\right) - \left(18.85 \times \frac{M_o}{R}\right) = 0$$

Solving the cubic equation:

$L_{e,z} = 0.74923 \text{ ft}$ - Required depth in z-direction,

Minimum embedded depth required:

$L_{e,req}$ - Depth of pile required,

$$L_{e,req} = \text{MAX}[L_{e,x}, L_{e,z}]$$

$$L_{e,req} = \text{MAX}[(6.3201 \text{ ft}), (0.74923 \text{ ft})]$$

$$L_{e,req} = 6.32 \text{ ft}$$

L_e - Actual embedded length of pile,

$$L_e = L - h_c - h_2$$

$$L_e = (7 \text{ ft}) - (0 \text{ ft}) - (0 \text{ ft})$$

$$L_e = 7 \text{ ft}$$

Ratio - Embedded depth

$$\text{Ratio} = \frac{L_{e,req}}{L_e}$$

$$\text{Ratio} = \frac{(6.32 \text{ ft})}{(7 \text{ ft})}$$

$$\text{Ratio} = 0.90286$$

Status: **PASS**
Ratio: **0.900**

End-bearing Capacity (ASD)

A - Pile cross-section area

$$A = b D$$

$$A = (48 \text{ in}) \times (48 \text{ in})$$

$$A = 16 \text{ ft}^2$$

q - End-bearing pressure

$$q = \frac{P_c}{A}$$

$$q = \frac{(5.664 \text{ kip})}{(16 \text{ ft}^2)}$$

$$q = 0.354 \text{ kip/ft}^2$$

$$q = 0.002 \text{ kip/ft}$$

Check bearing capacity ratio:

Ratio - Capacity

$$Ratio = \frac{q}{q_a}$$

$$Ratio = \frac{(0.354 \text{ kip/ft}^2)}{(2000 \text{ psf})}$$

$$Ratio = 0.177$$

Status: **PASS**
Ratio: **0.180**

Czerniak

Lateral Soil Pressure (ASD):

L/D - Length to least lateral dimension ratio,

$$L/D = \frac{L}{D}$$

$$L/D = \frac{(7 \text{ ft})}{(48 \text{ in})}$$

$$L/D = 1.75$$

Since $L/D \leq 10$,

Pile is short.

Considering x-direction:

$H_o = -0.53137 \text{ kip/ft}$ - Lateral force per length of pile,

$M_o = 5.6744 \text{ kipft/ft}$ - Overturning moment per length of pile,

a - Distance from resting surface to pivot point,

$$a = \frac{(4 M_o L_e) + (3 H_o L_e^2)}{(6 M_o) + (4 H_o L_e)}$$

$$a = \frac{(4 \times (5.6744 \text{ kipft/ft}) \times (7 \text{ ft})) + (3 \times (-0.53137 \text{ kip/ft}) \times (7 \text{ ft})^2)}{(6 \times (5.6744 \text{ kipft/ft})) + (4 \times (-0.53137 \text{ kip/ft}) \times (7 \text{ ft}))}$$

$$a = 4.8441 \text{ ft}$$

p - Earth pressure against the pile at distance $a/2$ from resting surface,

$$p = \frac{0.75 [(4 M_o) + (3 H_o L_e)]^2}{L_e^2 [(3 M_o) + (2 H_o L_e)]}$$

$$p = \frac{0.75 \times [(4 \times (5.6744 \text{ kipft/ft})) + (3 \times (-0.53137 \text{ kip/ft}) \times (7 \text{ ft}))]^2}{(7 \text{ ft})^2 \times [(3 \times (5.6744 \text{ kipft/ft})) + (2 \times (-0.53137 \text{ kip/ft}) \times (7 \text{ ft}))]}$$

$$p = 0.21264 \text{ kip/ft}^2$$

s - Earth pressure against the pile at distance L_e ,

$$s = \frac{6 [(2 M_o) + (H_o L_e)]}{L_e^2}$$

$$s = \frac{6 \times [(2 \times (5.6744 \text{ kipft/ft})) + ((-0.53137 \text{ kip/ft}) \times (7 \text{ ft}))]}{(7 \text{ ft})^2}$$

$$s = 0.93418 \text{ kip/ft}^2$$

Check lateral soil pressure capacity:

p_a - Allowable lateral soil pressure at depth $a/2$,

$$p_a = R \frac{a}{2}$$

$$p_a = (150 \text{ psf/ft}) \times \frac{(4.8441 \text{ ft})}{2}$$

$$p_a = 0.3633 \text{ kip/ft}^2$$

Ratio - Lateral soil capacity

$$Ratio = \frac{p}{p_a}$$

$$Ratio = \frac{(0.21264 \text{ kip/ft}^2)}{(0.3633 \text{ kip/ft}^2)}$$

$$Ratio = 0.58528$$

p_a - Allowable lateral soil pressure at depth L_e ,

Status: **PASS**
Ratio: **0.590**

	$p_s = R L_e$ $p_s = (150 \text{ psf/ft}) \times (7 \text{ ft})$ $p_s = 1.05 \text{ kip/ft}^2$ <p>Ratio - Lateral soil capacity</p> $\text{Ratio} = \frac{s}{p_s}$ $\text{Ratio} = \frac{(0.93418 \text{ kip/ft}^2)}{(1.05 \text{ kip/ft}^2)}$ $\text{Ratio} = 0.8897$	Status: PASS Ratio: 0.890
	<p>Considering z-direction:</p> <p>$H_o = -0.0025478 \text{ kip/ft}$ - Lateral force per length of pile, $M_o = 0.0066879 \text{ kipft/ft}$ - Overturning moment per length of pile, a - Distance from resting surface to pivot point,</p> $a = \frac{(4 M_o L_e) + (3 H_o L_e^2)}{(6 M_o) + (4 H_o L_e)}$ $a = \frac{(4 \times (0.0066879 \text{ kipft/ft}) \times (7 \text{ ft})) + (3 \times (-0.0025478 \text{ kip/ft}) \times (7 \text{ ft})^2)}{(6 \times (0.0066879 \text{ kipft/ft})) + (4 \times (-0.0025478 \text{ kip/ft}) \times (7 \text{ ft}))}$ $a = 5.04 \text{ ft}$ <p>p - Earth pressure against the pile at distance $a/2$ from resting surface,</p> $p = \frac{0.75 [(4 M_o) + (3 H_o L_e)]^2}{L_e^2 [(3 M_o) + (2 H_o L_e)]}$ $p = \frac{0.75 \times [(4 \times (0.0066879 \text{ kipft/ft})) + (3 \times (-0.0025478 \text{ kip/ft}) \times (7 \text{ ft}))]^2}{(7 \text{ ft})^2 \times [(3 \times (0.0066879 \text{ kipft/ft})) + (2 \times (-0.0025478 \text{ kip/ft}) \times (7 \text{ ft}))]}$ $p = -0.00070194 \text{ kip/ft}^2$ <p>s - Earth pressure against the pile at distance L_e,</p> $s = \frac{6 [(2 M_o) + (H_o L_e)]}{L_e^2}$ $s = \frac{6 \times [(2 \times (0.0066879 \text{ kipft/ft})) + ((-0.0025478 \text{ kip/ft}) \times (7 \text{ ft}))]}{(7 \text{ ft})^2}$ $s = -0.00054595 \text{ kip/ft}^2$ <p>Check lateral soil pressure capacity:</p> <p>p_a - Allowable lateral soil pressure at depth $a/2$,</p> $p_a = R \frac{a}{2}$ $p_a = (150 \text{ psf/ft}) \times \frac{(5.04 \text{ ft})}{2}$ $p_a = 0.378 \text{ kip/ft}^2$ <p>Ratio - Lateral soil capacity</p> $\text{Ratio} = \frac{p}{p_a}$ $\text{Ratio} = \frac{(-0.00070194 \text{ kip/ft}^2)}{(0.378 \text{ kip/ft}^2)}$ $\text{Ratio} = -0.001857$ <p>p_s - Allowable lateral soil pressure at depth L_e,</p> $p_s = R L_e$ $p_s = (150 \text{ psf/ft}) \times (7 \text{ ft})$ $p_s = 1.05 \text{ kip/ft}^2$ <p>Ratio - Lateral soil capacity</p> $\text{Ratio} = \frac{s}{p_s}$	Status: PASS Ratio: 0.000

$$Ratio = \frac{(-0.00054595 \text{ kip/ft}^2)}{(1.05 \text{ kip/ft}^2)}$$

$$Ratio = -0.00051995$$

Status: **PASS**
Ratio: **0.000**



Shear force and Bending moment (x-direction, LRF)

H_o - Lateral force per length of pile,

$$H_o = \frac{V_e}{1.57 D}$$

$$H_o = \frac{(-5.562 \text{ kip})}{1.57 \times (48 \text{ in})}$$

$$H_o = -0.88567 \text{ kip/ft}$$

M_o - Moment per length of pile,

$$M_o = \frac{M_z + (V_x H)}{1.57 D}$$

$$M_o = \frac{(59.908 \text{ kipft}) + ((-5.562 \text{ kip}) \times (0 \text{ ft}))}{1.57 \times (48 \text{ in})}$$

$$M_o = 9.5395 \text{ kipft/ft}$$

E - Distance from lateral load to resisting surface,

$$E = \frac{M_o}{H_o}$$

$$E = \frac{(9.5395 \text{ kipft/ft})}{(-0.88567 \text{ kip/ft})}$$

$$E = 10.771 \text{ ft}$$

a - Distance from resting surface to pivot point,

$$a = \frac{(4 M_o L_e) + (3 H_o L_e^2)}{(6 M_o) + (4 H_o L_e)}$$

$$a = \frac{(4 \times (9.5395 \text{ kipft/ft}) \times (7 \text{ ft})) + (3 \times (-0.88567 \text{ kip/ft}) \times (7 \text{ ft})^2)}{(6 \times (9.5395 \text{ kipft/ft})) + (4 \times (-0.88567 \text{ kip/ft}) \times (7 \text{ ft}))}$$

$$a = 4.843 \text{ ft}$$

V_{max} - Max shear force located at depth a ,

$$V_{max} = (H_o D) \left[1 - \left[3 \left(\frac{4 E}{L_e} + 3 \right) \left(\frac{a}{L_e} \right)^2 \right] + \left[4 \left(\frac{3 E}{L_e} + 2 \right) \left(\frac{a}{L_e} \right)^3 \right] \right]$$

$$V_{max} = ((-0.88567 \text{ kip/ft}) \times (48 \text{ in})) \times \left[1 - \left[3 \times \left(\frac{4 \times (10.771 \text{ ft})}{(7 \text{ ft})} + 3 \right) \times \left(\frac{(4.843 \text{ ft})}{(7 \text{ ft})} \right)^2 \right] + \left[4 \times \left(\frac{3 \times (10.771 \text{ ft})}{(7 \text{ ft})} + 2 \right) \times \left(\frac{(4.843 \text{ ft})}{(7 \text{ ft})} \right)^3 \right] \right]$$

$$V_{max} = 11.982 \text{ kip}$$

M_{max} - Max bending moment located at depth $a/2$,

$$M_{max} = (H_o D L_e) \left[\left(\frac{E}{L_e} + \frac{a}{2 L_e} \right) - \left[\left(\frac{4E}{L_e} + 3 \right) \left(\frac{a}{2 L_e} \right)^3 + \left[\left(\frac{3E}{L_e} + 2 \right) \left(\frac{a}{2 L_e} \right)^4 \right] \right] \right]$$

$$M_{max} = ((-0.88567 \text{ kip/ft}) \times (48 \text{ in}) \times (7 \text{ ft})) \times \left[\left(\frac{(10.771 \text{ ft})}{(7 \text{ ft})} + \frac{(4.843 \text{ ft})}{2 \times (7 \text{ ft})} \right) - \left[\left(\frac{4 \times (10.771 \text{ ft})}{(7 \text{ ft})} + 3 \right) \times \left(\frac{(4.843 \text{ ft})}{2 \times (7 \text{ ft})} \right)^3 + \left[\left(\frac{3 \times (10.771 \text{ ft})}{(7 \text{ ft})} + 2 \right) \times \left(\frac{(4.843 \text{ ft})}{2 \times (7 \text{ ft})} \right)^4 \right] \right] \right]$$

$$M_{max} = 39.688 \text{ kipft}$$

Shear force and Bending moment (z-direction, LRFD)

H_o - Lateral force per length of pile,

$$H_o = \frac{V_z}{1.57 b}$$

$$H_o = \frac{(-0.027 \text{ kip})}{1.57 \times (48 \text{ in})}$$

$$H_o = -0.0042994 \text{ kip/ft}$$

M_o - Moment per length of pile,

$$M_o = \frac{M_x + (V_z H)}{1.57 b}$$

$$M_o = \frac{(0.069 \text{ kipft}) + ((-0.027 \text{ kip}) \times (0 \text{ ft}))}{1.57 \times (48 \text{ in})}$$

$$M_o = 0.010987 \text{ kipft/ft}$$

E - Distance from lateral load to resisting surface,

$$E = \frac{M_o}{H_o}$$

$$E = \frac{(0.010987 \text{ kipft/ft})}{(-0.0042994 \text{ kip/ft})}$$

$$E = 2.5556 \text{ ft}$$

a - Distance from resting surface to pivot point,

$$a = \frac{(4 M_o L_e) + (3 H_o L_e^2)}{(6 M_o) + (4 H_o L_e)}$$

$$a = \frac{(4 \times (0.010987 \text{ kipft/ft}) \times (7 \text{ ft})) + (3 \times (-0.0042994 \text{ kip/ft}) \times (7 \text{ ft})^2)}{(6 \times (0.010987 \text{ kipft/ft})) + (4 \times (-0.0042994 \text{ kip/ft}) \times (7 \text{ ft}))}$$

$$a = 5.0436 \text{ ft}$$

V_{max} - Max shear force located at depth a ,

$$V_{max} = (H_o b) \left[1 - \left[3 \left(\frac{4E}{L_e} + 3 \right) \left(\frac{a}{L_e} \right)^2 + 4 \left(\frac{3E}{L_e} + 2 \right) \left(\frac{a}{L_e} \right)^3 \right] \right]$$

$$V_{max} = ((-0.0042994 \text{ kip/ft}) \times (48 \text{ in})) \times \left[1 - \left[3 \times \left(\frac{4 \times (2.5556 \text{ ft})}{(7 \text{ ft})} + 3 \right) \times \left(\frac{(5.0436 \text{ ft})}{(7 \text{ ft})} \right)^2 + 4 \times \left(\frac{3 \times (2.5556 \text{ ft})}{(7 \text{ ft})} + 2 \right) \times \left(\frac{(5.0436 \text{ ft})}{(7 \text{ ft})} \right)^3 \right] \right]$$

$$V_{max} = 0.022624 \text{ kip}$$

M_{max} - Max bending moment located at depth $a/2$,

$$M_{max} = (H_o b L_e) \left[\left(\frac{E}{L_e} + \frac{a}{2 L_e} \right) - \left[\left(\frac{4E}{L_e} + 3 \right) \left(\frac{a}{2 L_e} \right)^3 + \left[\left(\frac{3E}{L_e} + 2 \right) \left(\frac{a}{2 L_e} \right)^4 \right] \right] \right]$$

$$M_{max} = ((-0.0042994 \text{ kip/ft}) \times (48 \text{ in}) \times (7 \text{ ft})) \times \left[\left(\frac{(2.5556 \text{ ft})}{(7 \text{ ft})} + \frac{(5.0436 \text{ ft})}{2 \times (7 \text{ ft})} \right) - \left[\left(\frac{4 \times (2.5556 \text{ ft})}{(7 \text{ ft})} + 3 \right) \times \left(\frac{(5.0436 \text{ ft})}{2 \times (7 \text{ ft})} \right)^3 + \left[\left(\frac{3 \times (2.5556 \text{ ft})}{(7 \text{ ft})} + 2 \right) \times \left(\frac{(5.0436 \text{ ft})}{2 \times (7 \text{ ft})} \right)^4 \right] \right] \right]$$

$$M_{max} = 0.068489 \text{ kipft}$$

Minimum Reinforcement Check (LRFD)

Parameters:

$f'_{ck} = 3 \text{ ksi}$ - Concrete strength,
 $f_{yk} = 60 \text{ ksi}$ - Longitudinal reinforcement strength,
 $\phi = 0.65$ - Reduction factor for axial strength,
 $\alpha = 0.8$ - Alpha factor for axial strength,
 $A_g = 2304 \text{ in}^2$ - Gross area of concrete,

Table 22.4.2.1

Longitudinal reinforcement:

Required reinforcement due to axial load, $A_{st,required}$

22.4.2.2, 10.6.1.1

$A_{st,required}$

$$A_{st,required} = \text{Min} \left[\frac{\frac{P}{\phi \alpha} - (0.85 f'_{ck} A_g)}{f_{yk} - (0.85 f'_{ck})}, (0.08 A_g) \right]$$

$$A_{st,required} = \text{Min} \left[\frac{\frac{(8.777 \text{ kip})}{(0.65) \times (0.8)} - (0.85 \times (3 \text{ ksi}) \times (2304 \text{ in}^2))}{(60 \text{ ksi}) - (0.85 \times (3 \text{ ksi}))}, (0.08 \times (2304 \text{ in}^2)) \right]$$

$$A_{st,required} = -101.97 \text{ in}^2$$

A_{min} - Governing minimum reinforcement area,

$$A_{min} = \text{Max} [A_{st,required}, (0.0018 A_g)]$$

$$A_{min} = \text{Max} [(-101.97 \text{ in}^2), (0.0018 \times (2304 \text{ in}^2))]$$

$$A_{min} = 4.1472 \text{ in}^2$$

n_{rebar} - Required number of reinforcement,

$$n_{rebar} = \frac{A_{min}}{A_{rebar}}$$

$$n_{rebar} = \frac{(4.1472 \text{ in}^2)}{(0.3068 \text{ in}^2)}$$

$$n_{rebar} = 14$$

A_{st} - Actual total reinforcement area,

$$A_{st} = n_{rebar} \frac{\pi d_{bar}^2}{4}$$

$$A_{st} = (14) \times \frac{\pi \times (0.625 \text{ in})^2}{4}$$

$$A_{st} = 4.2951 \text{ in}^2$$

Ratio - Capacity

$$\text{Ratio} = \frac{A_{min}}{A_{st}}$$

$$\text{Ratio} = \frac{(4.1472 \text{ in}^2)}{(4.2951 \text{ in}^2)}$$

$$\text{Ratio} = 0.96556$$

Status: **PASS**
Ratio: **0.970**

25.2.3

s_{rebar} - Minimum spacing of reinforcement,

$$s_{rebar} = \text{Max} [1.5, (1.5 d_{bar})]$$

$$s_{rebar} = \text{Max} [1.5, (1.5 \times (0.625 \text{ in}))]$$

$$s_{rebar} = 1.5 \text{ in}$$

Ties:

25.7.2.2

Since longitudinal reinforcement is \leq No. 10: Use #3(0.375 in)

25.7.2.1

s_{ties} - Maximum spacing of ties,

$$s_{ties} = \text{Min} [(16 d_{bar}), (48 d_{ties}), \text{Min} (D, b)]$$

$$s_{ties} = \text{Min} [(16 \times (0.625 \text{ in})), (48 \times (0.375 \text{ in})), \text{Min} ((48 \text{ in}), (48 \text{ in}))]$$

$$s_{ties} = 10 \text{ in}$$

Summary:

Main reinforcement: **14 - #5 (0.625 in)**

Ties: #3(0.375 in) - 10 in

Axial Compression Strength (ACI 318-19, LRFD)

22.4.2.2

ϕP_N - Allowable axial compressive strength

$$\phi P_N = \phi 0.80 [(0.85 f'_{ck} [A_g - A_{st}] + (f_{yk} A_{st})]$$

$$\phi P_N = (0.65) \times 0.80 \times [(0.85 \times (3 \text{ ksi}) \times [(2304 \text{ in}^2) - (4.2951 \text{ in}^2)]) + ((60 \text{ ksi}) \times (4.2951 \text{ in}^2))]$$

$$\phi P_N = 3183.4 \text{ kip}$$

Ratio - Capacity

$$\text{Ratio} = \frac{P}{\phi P_N}$$

$$\text{Ratio} = \frac{(8.777 \text{ kip})}{(3183.4 \text{ kip})}$$

$$\text{Ratio} = 0.0027571$$

Status: **PASS**
Ratio: **0.000**

Shear Strength (ACI 318-19, LRFD)

Parameters:

22.5.2.2

$b_w = 48 \text{ in}$ - Effective width,
 d - Effective depth

$$d = 0.80 D$$

$$d = 0.80 \times (48 \text{ in})$$

$$d = 38.4 \text{ in}$$

22.5.5.1.3

λ_s - size effect modification factor

$$\lambda_s = \text{MIN} \left[\sqrt{\frac{2}{1 + \frac{d}{10}}}, 1 \right]$$

$$\lambda_s = \text{MIN} \left[\sqrt{\frac{2}{1 + \frac{(38.4 \text{ in})}{10}}}, 1 \right]$$

$$\lambda_s = 0.64282$$

22.5.5.1.1

The following variables were converted to be consistent with empirical formula $f'_{ck} = 3 \text{ ksi} \rightarrow 3000 \text{ psi}$,
 $V_{c,max}$ - Max shear strength of concrete

$$V_{c,max} = 5 \lambda_s \sqrt{f'_{ck}} b_w d$$

$$V_{c,max} = 5 \times (0.64282) \times \sqrt{(3000 \text{ psi})} \times (48 \text{ in}) \times (38.4 \text{ in})$$

$$V_{c,max} = 324.49 \text{ kip}$$

22.5.5.1.1(a)

The following variables were converted to be consistent with empirical formula $f'_{ck} = 3 \text{ ksi} \rightarrow 3000 \text{ psi}$, $P = 8.777 \text{ kip} \rightarrow 8777 \text{ lbf}$,
 $V_{c,a}$ - Shear strength of concrete (a)

$$V_{c,a} = \left[2 \lambda_s \sqrt{f'_{ck}} + \frac{P}{6 A_g} \right] b_w d$$

$$V_{c,a} = \left[2 \times (0.64282) \times \sqrt{(3000 \text{ psi})} + \frac{(8777 \text{ lbf})}{6 \times (2304 \text{ in}^2)} \right] \times (48 \text{ in}) \times (38.4 \text{ in})$$

$$V_{c,a} = 130.96 \text{ kip}$$

22.5.5.1.2

The following variables were converted to be consistent with empirical formula $f'_{ck} = 3 \text{ ksi} \rightarrow 3000 \text{ psi}$,
 $V_{c,b}$ - Shear strength of concrete (b)

$$V_{c,b} = \left[2 \lambda_s \sqrt{f'_{ck}} + (0.05 f'_{ck}) \right] b_w d$$

$$V_{c,b} = \left[2 \times (0.64282) \times \sqrt{(3000 \text{ psi})} + (0.05 \times (3000 \text{ psi})) \right] \times (48 \text{ in}) \times (38.4 \text{ in})$$

$$V_{c,b} = 406.27 \text{ kip}$$

V_c - Governing shear strength of concrete

$$V_c = \text{Min}[V_{c,max}, V_{c,a}, V_{c,b}]$$

$$V_c = \text{Min}[(324.49 \text{ kip}), (130.96 \text{ kip}), (406.27 \text{ kip})]$$

$$V_c = 130.96 \text{ kip}$$

<p>22.5.1.2</p>	<p>The following variables were converted to be consistent with empirical formula $f'_{ck} = 3 \text{ ksi} \rightarrow 3000 \text{ psi}$, $V_{s,a}$ - Shear strength of steel (a)</p> $V_{s,a} = 8 \sqrt{f'_{ck}} b_w d$ $V_{s,a} = 8 \times \sqrt{(3000 \text{ psi})} \times (48 \text{ in}) \times (38.4 \text{ in})$ $V_{s,a} = 807.65 \text{ kip}$ <p>A_v - Ties rebar area,</p> $A_v = \frac{\pi d_{ties}^2}{4}$ $A_v = \frac{\pi \times (0.375 \text{ in})^2}{4}$ $A_v = 0.11045 \text{ in}^2$ <p>22.5.8.5.3 $V_{s,b}$ - Shear strength of steel (b)</p> $V_{s,b} = \frac{2 A_v f_{yt} d}{s_{ties}}$ $V_{s,b} = \frac{2 \times (0.11045 \text{ in}^2) \times (60 \text{ ksi}) \times (38.4 \text{ in})}{(10 \text{ in})}$ $V_{s,b} = 50.894 \text{ kip}$ <p>V_s - Governing shear strength of steel</p> $V_s = \text{MIN}[V_{s,a}, V_{s,b}]$ $V_s = \text{MIN}[(807.65 \text{ kip}), (50.894 \text{ kip})]$ $V_s = 50.894 \text{ kip}$ <p>22.5.1.1 ϕV_n - Allowable shear strength</p> $\phi V_n = \phi (V_c + V_s)$ $\phi V_n = (0.65) \times ((130.96 \text{ kip}) + (50.894 \text{ kip}))$ $\phi V_n = 118.21 \text{ kip}$ <p>Considering x-direction:</p> <p>$V_{max} = 11.982 \text{ kip}$ - Maximum shear force in the x-direction, Ratio - Capacity</p> $\text{Ratio} = \frac{V_{max}}{\phi V_n}$ $\text{Ratio} = \frac{(11.982 \text{ kip})}{(118.21 \text{ kip})}$ $\text{Ratio} = 0.10136$ <p>Considering z-direction:</p> <p>$V_{max} = 0.022624 \text{ kip}$ - Maximum shear force in the z-direction, Ratio - Capacity</p> $\text{Ratio} = \frac{V_{max}}{\phi V_n}$ $\text{Ratio} = \frac{(0.022624 \text{ kip})}{(118.21 \text{ kip})}$ $\text{Ratio} = 0.00019139$	<p>Status: PASS Ratio: 0.100</p> <p>Status: PASS Ratio: 0.000</p>
	<p>Flexural Strength (ACI 318-19, LRFD)</p> <p>S_m - Section modulus</p> $S_m = \frac{b D^2}{6}$ $S_m = \frac{(48 \text{ in}) \times (48 \text{ in})^2}{6}$ $S_m = 18432 \text{ in}^3$	

<p>14.5.2.1b</p>	<p>$\lambda = 1$ - Concrete modification factor (Normal concrete), Allowable flexural strength: M_n shall be the lesser of: $\phi M_{n,1}$</p> $\phi M_{n,1} = \phi \times 5 \times \lambda \times \sqrt{f'_c} \times S_m$ $\phi M_{n,1} = 0.65 \times 5 \times 1 \times \sqrt{3\text{ksi}} \times 18432.001\text{in}^3$ $\phi M_{n,1} = 273.423\text{kipft}$ <p>$\phi M_{n,2}$</p> $\phi M_{n,2} = \phi \times 0.85 \times f'_c \times S_m$ $\phi M_{n,2} = (0.65) \times 0.85 \times (3\text{ksi}) \times (18432\text{in}^3)$ $\phi M_{n,2} = 2545.9\text{kipft}$ <p>Therefore, ϕM_n - Allowable flexural strength,</p> $\phi M_n = \text{MIN}[\phi M_{n,1}, \phi M_{n,2}]$ $\phi M_n = \text{MIN}[(273.42\text{kipft}), (2545.9\text{kipft})]$ $\phi M_n = 273.42\text{kipft}$ <p>Considering x-direction: $M_{max} = 39.688\text{kipft}$ - Maximum moment in the x-direction, Ratio - Capacity</p> $\text{Ratio} = \frac{M_{max}}{\phi M_n}$ $\text{Ratio} = \frac{(39.688\text{kipft})}{(273.42\text{kipft})}$ $\text{Ratio} = 0.14515$	<p>Status: PASS Ratio: 0.150</p>
	<p>Considering z-direction: $M_{max} = 0.068489\text{kipft}$ - Maximum moment in the z-direction, Ratio - Capacity</p> $\text{Ratio} = \frac{M_{max}}{\phi M_n}$ $\text{Ratio} = \frac{(0.068489\text{kipft})}{(273.42\text{kipft})}$ $\text{Ratio} = 0.00025049$	<p>Status: PASS Ratio: 0.000</p>

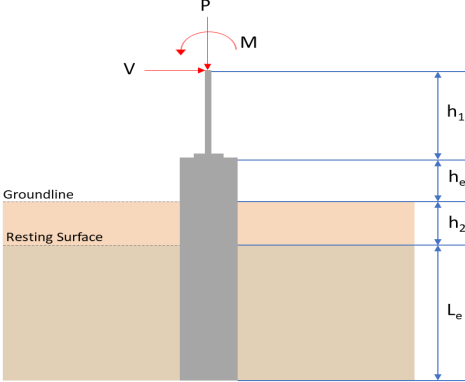
REFERENCES	CALCULATIONS	RESULTS																										
	<p>SkyCiv Foundation Design Pile Foundation</p> <p>Design Information : Design code : IBC 2021 (International Building Code) Unit System : Imperial</p>																											
	<p>Pile Input</p>  <p>Geometry Pile shape: rectangular $b = 48$ in - Pile width $D = 48$ in - Pile depth $L = 7$ ft - Total pile length $h_1 = 0$ ft - Lateral load height from the top of the pile, $h_2 = 0$ ft - Depth to resting surface $h_e = 0$ ft - Length of pile above the ground</p> <p>Tabulation of Soil Parameters</p> <table border="1" data-bbox="416 1102 1193 1191"> <thead> <tr> <th>Layer</th> <th>Label</th> <th>Allowable Bearing Pressure (q_a) (psf)</th> <th>Allowable Lateral Pressure (R) (psf/ft)</th> </tr> </thead> <tbody> <tr> <td>1</td> <td>Sand, silty sand, clayey sand, silty gravel & clayey gravel</td> <td>2000.000</td> <td>150.000</td> </tr> </tbody> </table> <p>Tabulation of Loads</p> <table border="1" data-bbox="676 1285 935 1458"> <thead> <tr> <th>Load Component</th> <th>ASD</th> <th>LRFD</th> </tr> </thead> <tbody> <tr> <td>P (kip)</td> <td>5.847</td> <td>9.027</td> </tr> <tr> <td>V_x (kip)</td> <td>-3.381</td> <td>-5.649</td> </tr> <tr> <td>V_z (kip)</td> <td>0.000</td> <td>0.000</td> </tr> <tr> <td>M_x (kipft)</td> <td>0.000</td> <td>0.000</td> </tr> <tr> <td>M_z (kipft)</td> <td>36.069</td> <td>60.583</td> </tr> </tbody> </table> <p>Material Properties $f'_{ck} = 3$ ksi - Concrete strength,</p>	Layer	Label	Allowable Bearing Pressure (q_a) (psf)	Allowable Lateral Pressure (R) (psf/ft)	1	Sand, silty sand, clayey sand, silty gravel & clayey gravel	2000.000	150.000	Load Component	ASD	LRFD	P (kip)	5.847	9.027	V_x (kip)	-3.381	-5.649	V_z (kip)	0.000	0.000	M_x (kipft)	0.000	0.000	M_z (kipft)	36.069	60.583	
Layer	Label	Allowable Bearing Pressure (q_a) (psf)	Allowable Lateral Pressure (R) (psf/ft)																									
1	Sand, silty sand, clayey sand, silty gravel & clayey gravel	2000.000	150.000																									
Load Component	ASD	LRFD																										
P (kip)	5.847	9.027																										
V_x (kip)	-3.381	-5.649																										
V_z (kip)	0.000	0.000																										
M_x (kipft)	0.000	0.000																										
M_z (kipft)	36.069	60.583																										
	<p>Required depth to resist lateral loads (ASD) H - Point of application of the lateral load</p> $H = h_1 + h_2 + h_e$ $H = (0 \text{ ft}) + (0 \text{ ft}) + (0 \text{ ft})$ $H = 0 \text{ ft}$ <p>Considering x-direction: H_o - Lateral force per length of pile,</p> $H_o = \frac{V_x}{1.57 D}$ $H_o = \frac{(-3.381 \text{ kip})}{1.57 \times (48 \text{ in})}$ $H_o = -0.53838 \text{ kip/ft}$ <p>M_o - Moment per length of pile,</p> $M_o = \frac{M_z + (V_x H)}{1.57 D}$																											

	$M_o = \frac{(36.069 \text{ kipft}) + ((-3.381 \text{ kip}) \times (0 \text{ ft}))}{1.57 \times (48 \text{ in})}$ $M_o = 5.7435 \text{ kipft/ft}$ <p>Required depth of embedment in earth:</p> $L_x^3 - \left(14.14 \times \frac{H_o \times L_x}{R}\right) - \left(18.85 \times \frac{M_o}{R}\right) = 0$ <p>Solving the cubic equation: $L_{e,x} = 6.3389 \text{ ft}$ - Required depth in x-direction,</p> <p>Considering z-direction: $L_{e,z} = 0 \text{ ft}$ - Required depth in z-direction,</p> <p>Minimum embedded depth required: $L_{e,req}$ - Depth of pile required,</p> $L_{e,req} = \text{MAX}[L_{e,x}, L_{e,z}]$ $L_{e,req} = \text{MAX}[(6.3389 \text{ ft}), (0 \text{ ft})]$ $L_{e,req} = 6.339 \text{ ft}$ <p>L_e - Actual embedded length of pile,</p> $L_e = L - h_e - h_2$ $L_e = (7 \text{ ft}) - (0 \text{ ft}) - (0 \text{ ft})$ $L_e = 7 \text{ ft}$ <p>Ratio - Embedded depth</p> $\text{Ratio} = \frac{L_{e,req}}{L_e}$ $\text{Ratio} = \frac{(6.339 \text{ ft})}{(7 \text{ ft})}$ $\text{Ratio} = 0.9057$	<p>Status: PASS Ratio: 0.910</p>
	<p>End-bearing Capacity (ASD) A - Pile cross-section area</p> $A = b D$ $A = (48 \text{ in}) \times (48 \text{ in})$ $A = 16 \text{ ft}^2$ <p>q - End-bearing pressure</p> $q = \frac{P_v}{A}$ $q = \frac{(5.847 \text{ kip})}{(16 \text{ ft}^2)}$ $q = 0.36544 \text{ kip/ft}^2$ <p>Check bearing capacity ratio: Ratio - Capacity</p> $\text{Ratio} = \frac{q}{q_o}$ $\text{Ratio} = \frac{(0.36544 \text{ kip/ft}^2)}{(2000 \text{ psf})}$ $\text{Ratio} = 0.18272$	<p>Status: PASS Ratio: 0.180</p>
<p>Czerniak</p>	<p>Lateral Soil Pressure (ASD): L/D - Length to least lateral dimension ratio,</p> $L/D = \frac{L}{D}$ $L/D = \frac{(7 \text{ ft})}{(48 \text{ in})}$	

$$L/D = 1.75$$

Since $L/D \leq 10$,

Pile is short.

Considering x-direction:

$H_o = -0.53838$ kip/ft - Lateral force per length of pile,

$M_o = 5.7435$ kipft/ft - Overturning moment per length of pile,

a - Distance from resting surface to pivot point,

$$a = \frac{(4 M_o L_e) + (3 H_o L_e^2)}{(6 M_o) + (4 H_o L_e)}$$

$$a = \frac{(4 \times (5.7435 \text{ kipft/ft}) \times (7 \text{ ft})) + (3 \times (-0.53838 \text{ kip/ft}) \times (7 \text{ ft})^2)}{(6 \times (5.7435 \text{ kipft/ft})) + (4 \times (-0.53838 \text{ kip/ft}) \times (7 \text{ ft}))}$$

$$a = 4.8442 \text{ ft}$$

p - Earth pressure against the pile at distance $a/2$ from resting surface,

$$p = \frac{0.75 [(4 M_o) + (3 H_o L_e)]^2}{L_e^2 [(3 M_o) + (2 H_o L_e)]}$$

$$p = \frac{0.75 \times [(4 \times (5.7435 \text{ kipft/ft})) + (3 \times (-0.53838 \text{ kip/ft}) \times (7 \text{ ft}))]^2}{(7 \text{ ft})^2 \times [(3 \times (5.7435 \text{ kipft/ft})) + (2 \times (-0.53838 \text{ kip/ft}) \times (7 \text{ ft}))]}$$

$$p = 0.21498 \text{ kip/ft}^2$$

s - Earth pressure against the pile at distance L_e ,

$$s = \frac{6 [(2 M_o) + (H_o L_e)]}{L_e^2}$$

$$s = \frac{6 \times [(2 \times (5.7435 \text{ kipft/ft})) + ((-0.53838 \text{ kip/ft}) \times (7 \text{ ft}))]}{(7 \text{ ft})^2}$$

$$s = 0.9451 \text{ kip/ft}^2$$

Check lateral soil pressure capacity:

p_a - Allowable lateral soil pressure at depth $a/2$,

$$p_a = R \frac{a}{2}$$

$$p_a = (150 \text{ psf/ft}) \times \frac{(4.8442 \text{ ft})}{2}$$

$$p_a = 0.36331 \text{ kip/ft}^2$$

Ratio - Lateral soil capacity

$$\text{Ratio} = \frac{p}{p_a}$$

$$\text{Ratio} = \frac{(0.21498 \text{ kip/ft}^2)}{(0.36331 \text{ kip/ft}^2)}$$

$$\text{Ratio} = 0.59171$$

p_s - Allowable lateral soil pressure at depth L_e ,

$$p_s = R L_e$$

$$p_s = (150 \text{ psf/ft}) \times (7 \text{ ft})$$

$$p_s = 1.05 \text{ kip/ft}^2$$

Ratio - Lateral soil capacity

$$\text{Ratio} = \frac{s}{p_s}$$

$$\text{Ratio} = \frac{(0.9451 \text{ kip/ft}^2)}{(1.05 \text{ kip/ft}^2)}$$

$$\text{Ratio} = 0.90009$$

Status: **PASS**
Ratio: **0.590**

Status: **PASS**
Ratio: **0.900**

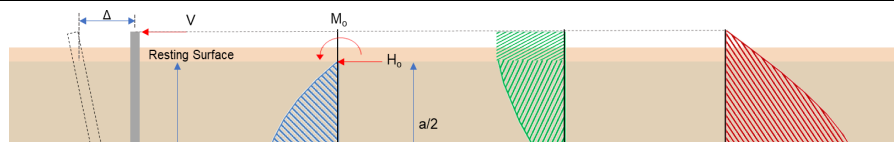

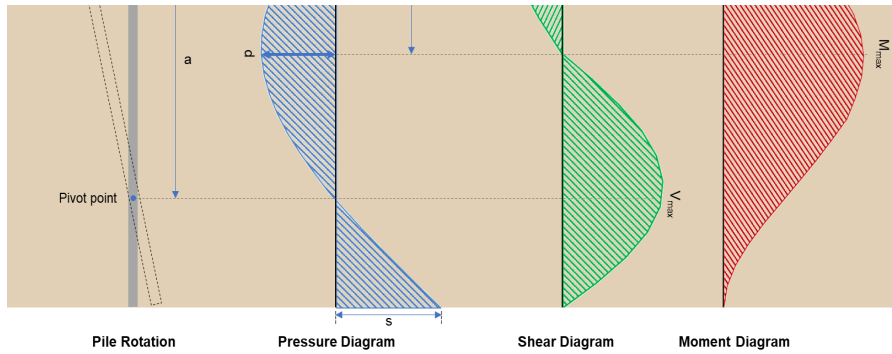

Shear force and Bending moment (x-direction, LRFD)

H_o - Lateral force per length of pile,

$$H_o = \frac{V_x}{1.57 D}$$

$$H_o = \frac{(-5.649 \text{ kip})}{1.57 \times (48 \text{ in})}$$

$$H_o = -0.89952 \text{ kip/ft}$$

M_o - Moment per length of pile,

$$M_o = \frac{M_x + (V_x H)}{1.57 D}$$

$$M_o = \frac{(60.583 \text{ kipft}) + ((-5.649 \text{ kip}) \times (0 \text{ ft}))}{1.57 \times (48 \text{ in})}$$

$$M_o = 9.647 \text{ kipft/ft}$$

E - Distance from lateral load to resisting surface,

$$E = \frac{M_o}{H_o}$$

$$E = \frac{(9.647 \text{ kipft/ft})}{(-0.89952 \text{ kip/ft})}$$

$$E = 10.725 \text{ ft}$$

a - Distance from resting surface to pivot point,

$$a = \frac{(4 M_o L_c) + (3 H_o L_c^2)}{(6 M_o) + (4 H_o L_c)}$$

$$a = \frac{(4 \times (9.647 \text{ kipft/ft}) \times (7 \text{ ft})) + (3 \times (-0.89952 \text{ kip/ft}) \times (7 \text{ ft})^2)}{(6 \times (9.647 \text{ kipft/ft})) + (4 \times (-0.89952 \text{ kip/ft}) \times (7 \text{ ft}))}$$

$$a = 4.8435 \text{ ft}$$

V_{max} - Max shear force located at depth a ,

$$V_{max} = (H_o D) \left[1 - \left[3 \left(\frac{4 E}{L_c} + 3 \right) \left(\frac{a}{L_c} \right)^2 \right] + \left[4 \left(\frac{3 E}{L_c} + 2 \right) \left(\frac{a}{L_c} \right)^3 \right] \right]$$

$$V_{max} = ((-0.89952 \text{ kip/ft}) \times (48 \text{ in})) \times \left[1 - \left[3 \times \left(\frac{4 \times (10.725 \text{ ft})}{(7 \text{ ft})} + 3 \right) \times \left(\frac{(4.8435 \text{ ft})}{(7 \text{ ft})} \right)^2 \right] + \left[4 \times \left(\frac{3 \times (10.725 \text{ ft})}{(7 \text{ ft})} + 2 \right) \times \left(\frac{(4.8435 \text{ ft})}{(7 \text{ ft})} \right)^3 \right] \right]$$

$$V_{max} = 12.127 \text{ kip}$$

M_{max} - Max bending moment located at depth $a/2$,

$$M_{max} = (H_o D L_c) \left[\left(\frac{E}{L_c} + \frac{a}{2 L_c} \right) - \left[\left(\frac{4 E}{L_c} + 3 \right) \left(\frac{a}{2 L_c} \right)^3 \right] + \left[\left(\frac{3 E}{L_c} + 2 \right) \left(\frac{a}{2 L_c} \right)^4 \right] \right]$$

$$M_{max} = ((-0.89952 \text{ kip/ft}) \times (48 \text{ in}) \times (7 \text{ ft})) \times \left[\left(\frac{(10.725 \text{ ft})}{(7 \text{ ft})} + \frac{(4.8435 \text{ ft})}{2 \times (7 \text{ ft})} \right) - \left[\left(\frac{4 \times (10.725 \text{ ft})}{(7 \text{ ft})} + 3 \right) \times \left(\frac{(4.8435 \text{ ft})}{2 \times (7 \text{ ft})} \right)^3 \right] + \left[\left(\frac{3 \times (10.725 \text{ ft})}{(7 \text{ ft})} + 2 \right) \times \left(\frac{(4.8435 \text{ ft})}{2 \times (7 \text{ ft})} \right)^4 \right] \right]$$

$$M_{max} = 40.161 \text{ kipft}$$

Minimum Reinforcement Check (LRFD)

Parameters:

$f'_{ck} = 3 \text{ ksi}$ - Concrete strength,
 $f_{yk} = 60 \text{ ksi}$ - Longitudinal reinforcement strength,
 $\phi = 0.65$ - Reduction factor for axial strength,
 $\alpha = 0.8$ - Alpha factor for axial strength,
 $A_g = 2304 \text{ in}^2$ - Gross area of concrete,

Table 22.4.2.1

Longitudinal reinforcement:

Required reinforcement due to axial load, $A_{st,required}$

22.4.2.2, 10.6.1.1

$A_{st,required}$

$$A_{st,required} = \text{Min} \left[\frac{\frac{P}{\phi \alpha} - (0.85 f'_{ck} A_g)}{f_{yk} - (0.85 f'_{ck})}, (0.08 A_g) \right]$$

$$A_{st,required} = \text{Min} \left[\frac{\frac{(9.027 \text{ kip})}{(0.65) \times (0.8)} - (0.85 \times (3 \text{ ksi}) \times (2304 \text{ in}^2))}{(60 \text{ ksi}) - (0.85 \times (3 \text{ ksi}))}, (0.08 \times (2304 \text{ in}^2)) \right]$$

$$A_{st,required} = -101.96 \text{ in}^2$$

A_{min} - Governing minimum reinforcement area,

$$A_{min} = \text{Max} [A_{st,required}, (0.0018 A_g)]$$

$$A_{min} = \text{Max} [(-101.96 \text{ in}^2), (0.0018 \times (2304 \text{ in}^2))]$$

$$A_{min} = 4.1472 \text{ in}^2$$

n_{rebar} - Required number of reinforcement,

$$n_{rebar} = \frac{A_{min}}{A_{rebar}}$$

$$n_{rebar} = \frac{(4.1472 \text{ in}^2)}{(0.3068 \text{ in}^2)}$$

$$n_{rebar} = 14$$

A_{st} - Actual total reinforcement area,

$$A_{st} = n_{rebar} \frac{\pi d_{bar}^2}{4}$$

$$A_{st} = (14) \times \frac{\pi \times (0.625 \text{ in})^2}{4}$$

$$A_{st} = 4.2951 \text{ in}^2$$

Ratio - Capacity

$$\text{Ratio} = \frac{A_{min}}{A_{st}}$$

$$\text{Ratio} = \frac{(4.1472 \text{ in}^2)}{(4.2951 \text{ in}^2)}$$

$$\text{Ratio} = 0.96556$$

Status: **PASS**
Ratio: **0.970**

25.2.3

s_{rebar} - Minimum spacing of reinforcement,

$$s_{rebar} = \text{Max} [1.5, (1.5 d_{bar})]$$

$$s_{rebar} = \text{Max} [1.5, (1.5 \times (0.625 \text{ in}))]$$

$$s_{rebar} = 1.5 \text{ in}$$

Ties:

25.7.2.2 Since longitudinal reinforcement is \leq No. 10: Use #3(0.375 in)

25.7.2.1

s_{ties} - Maximum spacing of ties,

$$s_{ties} = \text{Min} [(16 d_{bar}), (48 d_{ties}), \text{Min} (D, b)]$$

$$s_{ties} = \text{Min} [(16 \times (0.625 \text{ in})), (48 \times (0.375 \text{ in})), \text{Min} ((48 \text{ in}), (48 \text{ in}))]$$

$$s_{ties} = 10 \text{ in}$$

Summary:

Main reinforcement: **14 - #5 (0.625 in)**

Axial Compression Strength (ACI 318-19, LRFD)22.4.2.2 ϕP_N - Allowable axial compressive strength

$$\phi P_N = \phi 0.80 [(0.85 f'_{ck} [A_g - A_{st}]) + (f_{yk} A_{st})]$$

$$\phi P_N = (0.65) \times 0.80 \times [(0.85 \times (3 \text{ ksi}) \times [(2304 \text{ in}^2) - (4.2951 \text{ in}^2)]) + ((60 \text{ ksi}) \times (4.2951 \text{ in}^2))]$$

$$\phi P_N = 3183.4 \text{ kip}$$

Ratio - Capacity

$$\text{Ratio} = \frac{P}{\phi P_N}$$

$$\text{Ratio} = \frac{(9.027 \text{ kip})}{(3183.4 \text{ kip})}$$

$$\text{Ratio} = 0.0028356$$

Status: **PASS**
Ratio: **0.000****Shear Strength (ACI 318-19, LRFD)****Parameters:** $b_w = 48 \text{ in}$ - Effective width,22.5.2.2 d - Effective depth

$$d = 0.80 D$$

$$d = 0.80 \times (48 \text{ in})$$

$$d = 38.4 \text{ in}$$

22.5.5.1.3 λ_s - size effect modification factor

$$\lambda_s = \text{MIN} \left[\sqrt{\frac{2}{1 + \frac{d}{10}}}, 1 \right]$$

$$\lambda_s = \text{MIN} \left[\sqrt{\frac{2}{1 + \frac{(38.4 \text{ in})}{10}}}, 1 \right]$$

$$\lambda_s = 0.64282$$

The following variables were converted to be consistent with empirical formula $f'_{ck} = 3 \text{ ksi} \rightarrow 3000 \text{ psi}$,22.5.5.1.1 $V_{c,max}$ - Max shear strength of concrete

$$V_{c,max} = 5 \lambda_s \sqrt{f'_{ck}} b_w d$$

$$V_{c,max} = 5 \times (0.64282) \times \sqrt{(3000 \text{ psi})} \times (48 \text{ in}) \times (38.4 \text{ in})$$

$$V_{c,max} = 324.49 \text{ kip}$$

The following variables were converted to be consistent with empirical formula $f'_{ck} = 3 \text{ ksi} \rightarrow 3000 \text{ psi}$, $P = 9.027 \text{ kip} \rightarrow 9027 \text{ lbf}$,22.5.5.1.1(a) $V_{c,a}$ - Shear strength of concrete (a)

$$V_{c,a} = \left[2 \lambda_s \sqrt{f'_{ck}} + \frac{P}{6 A_g} \right] b_w d$$

$$V_{c,a} = \left[2 \times (0.64282) \times \sqrt{(3000 \text{ psi})} + \frac{(9027 \text{ lbf})}{6 \times (2304 \text{ in}^2)} \right] \times (48 \text{ in}) \times (38.4 \text{ in})$$

$$V_{c,a} = 131 \text{ kip}$$

The following variables were converted to be consistent with empirical formula $f'_{ck} = 3 \text{ ksi} \rightarrow 3000 \text{ psi}$,22.5.5.1.2 $V_{c,b}$ - Shear strength of concrete (b)

$$V_{c,b} = \left[2 \lambda_s \sqrt{f'_{ck}} + (0.05 f'_{ck}) \right] b_w d$$

$$V_{c,b} = \left[2 \times (0.64282) \times \sqrt{(3000 \text{ psi})} + (0.05 \times (3000 \text{ psi})) \right] \times (48 \text{ in}) \times (38.4 \text{ in})$$

$$V_{c,b} = 406.27 \text{ kip}$$

 V_c - Governing shear strength of concrete

$$V_c = \text{Min}[V_{c,max}, V_{c,a}, V_{c,b}]$$

$$V_c = \text{Min}[(324.49 \text{ kip}), (131 \text{ kip}), (406.27 \text{ kip})]$$

$$V_c = 131 \text{ kip}$$

<p>22.5.1.2</p>	<p>The following variables were converted to be consistent with empirical formula $f'_{ck} = 3 \text{ ksi} \rightarrow 3000 \text{ psi}$.</p> <p>$V_{s,a}$ - Shear strength of steel (a)</p> $V_{s,a} = 8 \sqrt{f'_{ck}} b_w d$ $V_{s,a} = 8 \times \sqrt{(3000 \text{ psi})} \times (48 \text{ in}) \times (38.4 \text{ in})$ $V_{s,a} = 807.65 \text{ kip}$ <p>A_v - Ties rebar area,</p> $A_v = \frac{\pi d_{ties}^2}{4}$ $A_v = \frac{\pi \times (0.375 \text{ in})^2}{4}$ $A_v = 0.11045 \text{ in}^2$ <p>22.5.8.5.3 $V_{s,b}$ - Shear strength of steel (b)</p> $V_{s,b} = \frac{2 A_v f_{ywk} d}{s_{ties}}$ $V_{s,b} = \frac{2 \times (0.11045 \text{ in}^2) \times (60 \text{ ksi}) \times (38.4 \text{ in})}{(10 \text{ in})}$ $V_{s,b} = 50.894 \text{ kip}$ <p>V_s - Governing shear strength of steel</p> $V_s = MIN[V_{s,a}, V_{s,b}]$ $V_s = MIN[(807.65 \text{ kip}), (50.894 \text{ kip})]$ $V_s = 50.894 \text{ kip}$ <p>22.5.1.1 ϕV_n - Allowable shear strength</p> $\phi V_n = \phi (V_c + V_s)$ $\phi V_n = (0.65) \times ((131 \text{ kip}) + (50.894 \text{ kip}))$ $\phi V_n = 118.23 \text{ kip}$ <p>Considering x-direction:</p> <p>$V_{max} = 12.127 \text{ kip}$ - Maximum shear force in the x-direction, Ratio - Capacity</p> $Ratio = \frac{V_{max}}{\phi V_n}$ $Ratio = \frac{(12.127 \text{ kip})}{(118.23 \text{ kip})}$ $Ratio = 0.10257$	<p>Status: PASS Ratio: 0.100</p>
<p>14.5.2.1b</p>	<p>Flexural Strength (ACI 318-19, LRFD)</p> <p>S_m - Section modulus</p> $S_m = \frac{b D^2}{6}$ $S_m = \frac{(48 \text{ in}) \times (48 \text{ in})^2}{6}$ $S_m = 18432 \text{ in}^3$ <p>$\lambda = 1$ - Concrete modification factor (Normal concrete), Allowable flexural strength: M_n shall be the lesser of:</p> <p>$\phi M_{n,1}$</p> $\phi M_{n,1} = \phi \times 5 \times \lambda \times \sqrt{f'_c} \times S_m$ $\phi M_{n,1} = 0.65 \times 5 \times 1 \times \sqrt{(3 \text{ ksi})} \times 18432.001 \text{ in}^3$ $\phi M_{n,1} = 273.423 \text{ kipft}$ <p>$\phi M_{n,2}$</p> $\phi M_{n,2} = 0.85 f'_c S_m$	

$\phi M_{n,z} = \phi S_{x,z} F_{ck} \leq m$

$$\phi M_{n,z} = (0.65) \times 0.85 \times (3 \text{ ksi}) \times (18432 \text{ in}^3)$$

$$\phi M_{n,z} = 2545.9 \text{ kipft}$$

Therefore,
 ϕM_n - Allowable flexural strength,

$$\phi M_n = \text{MIN}[\phi M_{n,1}, \phi M_{n,2}]$$

$$\phi M_n = \text{MIN}[(273.42 \text{ kipft}), (2545.9 \text{ kipft})]$$

$$\phi M_n = 273.42 \text{ kipft}$$

Considering x-direction:

$M_{max} = 40.161 \text{ kipft}$ - Maximum moment in the x-direction,

Ratio - Capacity

$$\text{Ratio} = \frac{M_{max}}{\phi M_n}$$

$$\text{Ratio} = \frac{(40.161 \text{ kipft})}{(273.42 \text{ kipft})}$$

$$\text{Ratio} = 0.14688$$

Status: **PASS**
Ratio: **0.150**

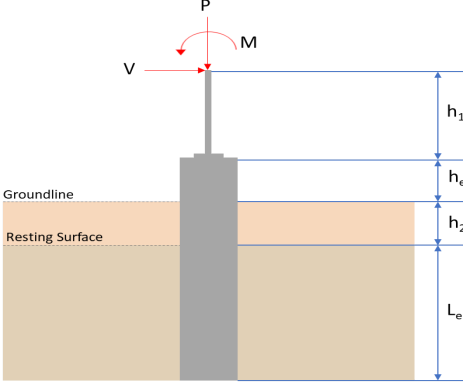
REFERENCES	CALCULATIONS	RESULTS																										
	<p>SkyCiv Foundation Design Pile Foundation</p> <p>Design Information : Design code : IBC 2021 (International Building Code) Unit System : Imperial</p>																											
	<p>Pile Input</p>  <p>Geometry Pile shape: rectangular $b = 48$ in - Pile width $D = 48$ in - Pile depth $L = 7$ ft - Total pile length $h_1 = 0$ ft - Lateral load height from the top of the pile, $h_2 = 0$ ft - Depth to resting surface $h_e = 0$ ft - Length of pile above the ground</p> <p>Tabulation of Soil Parameters</p> <table border="1" data-bbox="416 1102 1193 1191"> <thead> <tr> <th>Layer</th> <th>Label</th> <th>Allowable Bearing Pressure (q_a) (psf)</th> <th>Allowable Lateral Pressure (R) (psf/ft)</th> </tr> </thead> <tbody> <tr> <td>1</td> <td>Sand, silty sand, clayey sand, silty gravel & clayey gravel</td> <td>2000.000</td> <td>150.000</td> </tr> </tbody> </table> <p>Tabulation of Loads</p> <table border="1" data-bbox="676 1288 933 1458"> <thead> <tr> <th>Load Component</th> <th>ASD</th> <th>LRFD</th> </tr> </thead> <tbody> <tr> <td>P (kip)</td> <td>5.664</td> <td>8.777</td> </tr> <tr> <td>V_x (kip)</td> <td>-3.337</td> <td>-5.562</td> </tr> <tr> <td>V_z (kip)</td> <td>0.016</td> <td>0.027</td> </tr> <tr> <td>M_x (kipft)</td> <td>0.042</td> <td>0.070</td> </tr> <tr> <td>M_z (kipft)</td> <td>35.635</td> <td>59.909</td> </tr> </tbody> </table> <p>Material Properties $f'_{ck} = 3$ ksi - Concrete strength,</p>	Layer	Label	Allowable Bearing Pressure (q_a) (psf)	Allowable Lateral Pressure (R) (psf/ft)	1	Sand, silty sand, clayey sand, silty gravel & clayey gravel	2000.000	150.000	Load Component	ASD	LRFD	P (kip)	5.664	8.777	V_x (kip)	-3.337	-5.562	V_z (kip)	0.016	0.027	M_x (kipft)	0.042	0.070	M_z (kipft)	35.635	59.909	
Layer	Label	Allowable Bearing Pressure (q_a) (psf)	Allowable Lateral Pressure (R) (psf/ft)																									
1	Sand, silty sand, clayey sand, silty gravel & clayey gravel	2000.000	150.000																									
Load Component	ASD	LRFD																										
P (kip)	5.664	8.777																										
V_x (kip)	-3.337	-5.562																										
V_z (kip)	0.016	0.027																										
M_x (kipft)	0.042	0.070																										
M_z (kipft)	35.635	59.909																										
	<p>Required depth to resist lateral loads (ASD) H - Point of application of the lateral load</p> $H = h_1 + h_2 + h_e$ $H = (0 \text{ ft}) + (0 \text{ ft}) + (0 \text{ ft})$ $H = 0 \text{ ft}$ <p>Considering x-direction: H_o - Lateral force per length of pile,</p> $H_o = \frac{V_x}{1.57 D}$ $H_o = \frac{(-3.337 \text{ kip})}{1.57 \times (48 \text{ in})}$ $H_o = -0.53137 \text{ kip/ft}$ <p>M_o - Moment per length of pile,</p> $M_o = \frac{M_z + (V_x H)}{1.57 D}$																											

$$M_o = \frac{(35.635 \text{ kipft}) + ((-3.337 \text{ kip}) \times (0 \text{ ft}))}{1.57 \times (48 \text{ in})}$$

$$M_o = 5.6744 \text{ kipft/ft}$$

Required depth of embedment in earth:

$$L_x^3 - \left(14.14 \times \frac{H_o \times L_x}{R}\right) - \left(18.85 \times \frac{M_o}{R}\right) = 0$$

Solving the cubic equation:

$L_{e,x} = 6.3201 \text{ ft}$ - Required depth in x-direction,

Considering z-direction:

H_o - Lateral force per length of pile,

$$H_o = \frac{V_z}{1.57 b}$$

$$H_o = \frac{(0.016 \text{ kip})}{1.57 \times (48 \text{ in})}$$

$$H_o = 0.0025478 \text{ kip/ft}$$

M_o - Moment per length of pile,

$$M_o = \frac{M_x + (V_z H)}{1.57 b}$$

$$M_o = \frac{(0.042 \text{ kipft}) + ((0.016 \text{ kip}) \times (0 \text{ ft}))}{1.57 \times (48 \text{ in})}$$

$$M_o = 0.0066879 \text{ kipft/ft}$$

Required depth of embedment in earth:

$$L_z^3 - \left(14.14 \times \frac{H_o \times L_z}{R}\right) - \left(18.85 \times \frac{M_o}{R}\right) = 0$$

Solving the cubic equation:

$L_{e,z} = 0.8746 \text{ ft}$ - Required depth in z-direction,

Minimum embedded depth required:

$L_{e,req}$ - Depth of pile required,

$$L_{e,req} = \text{MAX}[L_{e,x}, L_{e,z}]$$

$$L_{e,req} = \text{MAX}[(6.3201 \text{ ft}), (0.8746 \text{ ft})]$$

$$L_{e,req} = 6.32 \text{ ft}$$

L_e - Actual embedded length of pile,

$$L_e = L - h_c - h_2$$

$$L_e = (7 \text{ ft}) - (0 \text{ ft}) - (0 \text{ ft})$$

$$L_e = 7 \text{ ft}$$

Ratio - Embedded depth

$$\text{Ratio} = \frac{L_{e,req}}{L_e}$$

$$\text{Ratio} = \frac{(6.32 \text{ ft})}{(7 \text{ ft})}$$

$$\text{Ratio} = 0.90286$$

Status: **PASS**
Ratio: **0.900**

End-bearing Capacity (ASD)

A - Pile cross-section area

$$A = b D$$

$$A = (48 \text{ in}) \times (48 \text{ in})$$

$$A = 16 \text{ ft}^2$$

q - End-bearing pressure

$$q = \frac{P_c}{A}$$

$$q = \frac{(5.664 \text{ kip})}{(16 \text{ ft}^2)}$$

$$q = 0.354 \text{ kip/ft}^2$$

$$q = 0.004 \text{ kip/ft}$$

Check bearing capacity ratio:

Ratio - Capacity

$$Ratio = \frac{q}{q_a}$$

$$Ratio = \frac{(0.354 \text{ kip/ft}^2)}{(2000 \text{ psf})}$$

$$Ratio = 0.177$$

Status: **PASS**
Ratio: **0.180**

Czerniak

Lateral Soil Pressure (ASD):

L/D - Length to least lateral dimension ratio,

$$L/D = \frac{L}{D}$$

$$L/D = \frac{(7 \text{ ft})}{(48 \text{ in})}$$

$$L/D = 1.75$$

Since $L/D \leq 10$,

Pile is short.

Considering x-direction:

$H_o = -0.53137 \text{ kip/ft}$ - Lateral force per length of pile,

$M_o = 5.6744 \text{ kipft/ft}$ - Overturning moment per length of pile,

a - Distance from resting surface to pivot point,

$$a = \frac{(4 M_o L_e) + (3 H_o L_e^2)}{(6 M_o) + (4 H_o L_e)}$$

$$a = \frac{(4 \times (5.6744 \text{ kipft/ft}) \times (7 \text{ ft})) + (3 \times (-0.53137 \text{ kip/ft}) \times (7 \text{ ft})^2)}{(6 \times (5.6744 \text{ kipft/ft})) + (4 \times (-0.53137 \text{ kip/ft}) \times (7 \text{ ft}))}$$

$$a = 4.8441 \text{ ft}$$

p - Earth pressure against the pile at distance $a/2$ from resting surface,

$$p = \frac{0.75 [(4 M_o) + (3 H_o L_e)]^2}{L_e^2 [(3 M_o) + (2 H_o L_e)]}$$

$$p = \frac{0.75 \times [(4 \times (5.6744 \text{ kipft/ft})) + (3 \times (-0.53137 \text{ kip/ft}) \times (7 \text{ ft}))]^2}{(7 \text{ ft})^2 \times [(3 \times (5.6744 \text{ kipft/ft})) + (2 \times (-0.53137 \text{ kip/ft}) \times (7 \text{ ft}))]}$$

$$p = 0.21264 \text{ kip/ft}^2$$

s - Earth pressure against the pile at distance L_e ,

$$s = \frac{6 [(2 M_o) + (H_o L_e)]}{L_e^2}$$

$$s = \frac{6 \times [(2 \times (5.6744 \text{ kipft/ft})) + ((-0.53137 \text{ kip/ft}) \times (7 \text{ ft}))]}{(7 \text{ ft})^2}$$

$$s = 0.93418 \text{ kip/ft}^2$$

Check lateral soil pressure capacity:

p_a - Allowable lateral soil pressure at depth $a/2$,

$$p_a = R \frac{a}{2}$$

$$p_a = (150 \text{ psf/ft}) \times \frac{(4.8441 \text{ ft})}{2}$$

$$p_a = 0.3633 \text{ kip/ft}^2$$

Ratio - Lateral soil capacity

$$Ratio = \frac{p}{p_a}$$

$$Ratio = \frac{(0.21264 \text{ kip/ft}^2)}{(0.3633 \text{ kip/ft}^2)}$$

$$Ratio = 0.58528$$

p_a - Allowable lateral soil pressure at depth L_e ,

Status: **PASS**
Ratio: **0.590**

	$p_s = R L_e$ $p_s = (150 \text{ psf/ft}) \times (7 \text{ ft})$ $p_s = 1.05 \text{ kip/ft}^2$ <p>Ratio - Lateral soil capacity</p> $\text{Ratio} = \frac{s}{p_s}$ $\text{Ratio} = \frac{(0.93418 \text{ kip/ft}^2)}{(1.05 \text{ kip/ft}^2)}$ $\text{Ratio} = 0.8897$	Status: PASS Ratio: 0.890
	<p>Considering z-direction:</p> <p>$H_o = 0.0025478 \text{ kip/ft}$ - Lateral force per length of pile, $M_o = 0.0066879 \text{ kipft/ft}$ - Overturning moment per length of pile, a - Distance from resting surface to pivot point,</p> $a = \frac{(4 M_o L_e) + (3 H_o L_e^2)}{(6 M_o) + (4 H_o L_e)}$ $a = \frac{(4 \times (0.0066879 \text{ kipft/ft}) \times (7 \text{ ft})) + (3 \times (0.0025478 \text{ kip/ft}) \times (7 \text{ ft})^2)}{(6 \times (0.0066879 \text{ kipft/ft})) + (4 \times (0.0025478 \text{ kip/ft}) \times (7 \text{ ft}))}$ $a = 5.04 \text{ ft}$ <p>p - Earth pressure against the pile at distance $a/2$ from resting surface,</p> $p = \frac{0.75 [(4 M_o) + (3 H_o L_e)]^2}{L_e^2 [(3 M_o) + (2 H_o L_e)]}$ $p = \frac{0.75 \times [(4 \times (0.0066879 \text{ kipft/ft})) + (3 \times (0.0025478 \text{ kip/ft}) \times (7 \text{ ft}))]^2}{(7 \text{ ft})^2 \times [(3 \times (0.0066879 \text{ kipft/ft})) + (2 \times (0.0025478 \text{ kip/ft}) \times (7 \text{ ft}))]}$ $p = 0.0017689 \text{ kip/ft}^2$ <p>s - Earth pressure against the pile at distance L_e,</p> $s = \frac{6 [(2 M_o) + (H_o L_e)]}{L_e^2}$ $s = \frac{6 \times [(2 \times (0.0066879 \text{ kipft/ft})) + ((0.0025478 \text{ kip/ft}) \times (7 \text{ ft}))]}{(7 \text{ ft})^2}$ $s = 0.0038217 \text{ kip/ft}^2$ <p>Check lateral soil pressure capacity:</p> <p>p_a - Allowable lateral soil pressure at depth $a/2$,</p> $p_a = R \frac{a}{2}$ $p_a = (150 \text{ psf/ft}) \times \frac{(5.04 \text{ ft})}{2}$ $p_a = 0.378 \text{ kip/ft}^2$ <p>Ratio - Lateral soil capacity</p> $\text{Ratio} = \frac{p}{p_a}$ $\text{Ratio} = \frac{(0.0017689 \text{ kip/ft}^2)}{(0.378 \text{ kip/ft}^2)}$ $\text{Ratio} = 0.0046796$ <p>p_s - Allowable lateral soil pressure at depth L_e,</p> $p_s = R L_e$ $p_s = (150 \text{ psf/ft}) \times (7 \text{ ft})$ $p_s = 1.05 \text{ kip/ft}^2$ <p>Ratio - Lateral soil capacity</p> $\text{Ratio} = \frac{s}{p_s}$	Status: PASS Ratio: 0.000

$$\text{Ratio} = \frac{(0.0038217 \text{ kip/ft}^2)}{(1.05 \text{ kip/ft}^2)}$$

$$\text{Ratio} = 0.0036397$$

Status: **PASS**
Ratio: **0.000**

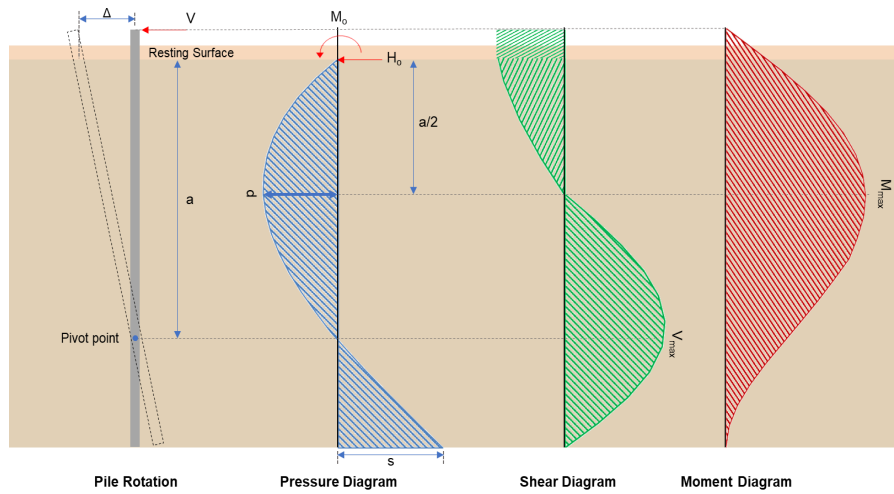

Shear force and Bending moment (x-direction, LRFD)

H_o - Lateral force per length of pile,

$$H_o = \frac{V_e}{1.57 D}$$

$$H_o = \frac{(-5.562 \text{ kip})}{1.57 \times (48 \text{ in})}$$

$$H_o = -0.88567 \text{ kip/ft}$$

M_o - Moment per length of pile,

$$M_o = \frac{M_z + (V_x H)}{1.57 D}$$

$$M_o = \frac{(59.91 \text{ kipft}) + ((-5.562 \text{ kip}) \times (0 \text{ ft}))}{1.57 \times (48 \text{ in})}$$

$$M_o = 9.5396 \text{ kipft/ft}$$

E - Distance from lateral load to resisting surface,

$$E = \frac{M_o}{H_o}$$

$$E = \frac{(9.5396 \text{ kipft/ft})}{(-0.88567 \text{ kip/ft})}$$

$$E = 10.771 \text{ ft}$$

a - Distance from resting surface to pivot point,

$$a = \frac{(4 M_o L_e) + (3 H_o L_e^2)}{(6 M_o) + (4 H_o L_e)}$$

$$a = \frac{(4 \times (9.5396 \text{ kipft/ft}) \times (7 \text{ ft})) + (3 \times (-0.88567 \text{ kip/ft}) \times (7 \text{ ft})^2)}{(6 \times (9.5396 \text{ kipft/ft})) + (4 \times (-0.88567 \text{ kip/ft}) \times (7 \text{ ft}))}$$

$$a = 4.843 \text{ ft}$$

V_{max} - Max shear force located at depth a ,

$$V_{max} = (H_o D) \left[1 - \left[3 \left(\frac{4 E}{L_e} + 3 \right) \left(\frac{a}{L_e} \right)^2 \right] + \left[4 \left(\frac{3 E}{L_e} + 2 \right) \left(\frac{a}{L_e} \right)^3 \right] \right]$$

$$V_{max} = ((-0.88567 \text{ kip/ft}) \times (48 \text{ in})) \times \left[1 - \left[3 \times \left(\frac{4 \times (10.771 \text{ ft})}{(7 \text{ ft})} + 3 \right) \times \left(\frac{(4.843 \text{ ft})}{(7 \text{ ft})} \right)^2 \right] + \left[4 \times \left(\frac{3 \times (10.771 \text{ ft})}{(7 \text{ ft})} + 2 \right) \times \left(\frac{(4.843 \text{ ft})}{(7 \text{ ft})} \right)^3 \right] \right]$$

$$V_{max} = 11.982 \text{ kip}$$

M_{max} - Max bending moment located at depth $a/2$,

$$M_{max} = (H_o D L_e) \left[\left(\frac{E}{L_e} + \frac{a}{2 L_e} \right) - \left[\left(\frac{4 E}{L_e} + 3 \right) \left(\frac{a}{2 L_e} \right)^3 \right] + \left[\left(\frac{3 E}{L_e} + 2 \right) \left(\frac{a}{2 L_e} \right)^4 \right] \right]$$

$$M_{max} = ((-0.88567 \text{ kip/ft}) \times (48 \text{ in}) \times (7 \text{ ft})) \times \left[\left(\frac{(10.771 \text{ ft})}{(7 \text{ ft})} + \frac{(4.843 \text{ ft})}{2 \times (7 \text{ ft})} \right) - \left[\left(\frac{4 \times (10.771 \text{ ft})}{(7 \text{ ft})} + 3 \right) \times \left(\frac{(4.843 \text{ ft})}{2 \times (7 \text{ ft})} \right)^3 \right] + \left[\left(\frac{3 \times (10.771 \text{ ft})}{(7 \text{ ft})} + 2 \right) \times \left(\frac{(4.843 \text{ ft})}{2 \times (7 \text{ ft})} \right)^4 \right] \right]$$

$$M_{max} = 39.689 \text{ kipft}$$

Shear force and Bending moment (z-direction, LRFD)

H_o - Lateral force per length of pile,

$$H_o = \frac{V_z}{1.57 b}$$

$$H_o = \frac{(0.027 \text{ kip})}{1.57 \times (48 \text{ in})}$$

$$H_o = 0.0042994 \text{ kip/ft}$$

M_o - Moment per length of pile,

$$M_o = \frac{M_x + (V_z H)}{1.57 b}$$

$$M_o = \frac{(0.07 \text{ kipft}) + ((0.027 \text{ kip}) \times (0 \text{ ft}))}{1.57 \times (48 \text{ in})}$$

$$M_o = 0.011146 \text{ kipft/ft}$$

E - Distance from lateral load to resisting surface,

$$E = \frac{M_o}{H_o}$$

$$E = \frac{(0.011146 \text{ kipft/ft})}{(0.0042994 \text{ kip/ft})}$$

$$E = 2.5926 \text{ ft}$$

a - Distance from resting surface to pivot point,

$$a = \frac{(4 M_o L_e) + (3 H_o L_e^2)}{(6 M_o) + (4 H_o L_e)}$$

$$a = \frac{(4 \times (0.011146 \text{ kipft/ft}) \times (7 \text{ ft})) + (3 \times (0.0042994 \text{ kip/ft}) \times (7 \text{ ft})^2)}{(6 \times (0.011146 \text{ kipft/ft})) + (4 \times (0.0042994 \text{ kip/ft}) \times (7 \text{ ft}))}$$

$$a = 5.0417 \text{ ft}$$

V_{max} - Max shear force located at depth a ,

$$V_{max} = (H_o b) \left[1 - \left[3 \left(\frac{4 E}{L_e} + 3 \right) \left(\frac{a}{L_e} \right)^2 \right] + \left[4 \left(\frac{3 E}{L_e} + 2 \right) \left(\frac{a}{L_e} \right)^3 \right] \right]$$

$$V_{max} = ((0.0042994 \text{ kip/ft}) \times (48 \text{ in})) \times \left[1 - \left[3 \times \left(\frac{4 \times (2.5926 \text{ ft})}{(7 \text{ ft})} + 3 \right) \times \left(\frac{(5.0417 \text{ ft})}{(7 \text{ ft})} \right)^2 \right] + \left[4 \times \left(\frac{3 \times (2.5926 \text{ ft})}{(7 \text{ ft})} + 2 \right) \times \left(\frac{(5.0417 \text{ ft})}{(7 \text{ ft})} \right)^3 \right] \right]$$

$$V_{max} = 0.022782 \text{ kip}$$

M_{max} - Max bending moment located at depth $a/2$,

$$M_{max} = (H_o b L_e) \left[\left(\frac{E}{L_e} + \frac{a}{2 L_e} \right) - \left[\left(\frac{4 E}{L_e} + 3 \right) \left(\frac{a}{2 L_e} \right)^3 \right] + \left[\left(\frac{3 E}{L_e} + 2 \right) \left(\frac{a}{2 L_e} \right)^4 \right] \right]$$

$$M_{max} = ((0.0042994 \text{ kip/ft}) \times (48 \text{ in}) \times (7 \text{ ft})) \times \left[\left(\frac{(2.5926 \text{ ft})}{(7 \text{ ft})} + \frac{(5.0417 \text{ ft})}{2 \times (7 \text{ ft})} \right) - \left[\left(\frac{4 \times (2.5926 \text{ ft})}{(7 \text{ ft})} + 3 \right) \times \left(\frac{(5.0417 \text{ ft})}{2 \times (7 \text{ ft})} \right)^3 \right] + \left[\left(\frac{3 \times (2.5926 \text{ ft})}{(7 \text{ ft})} + 2 \right) \times \left(\frac{(5.0417 \text{ ft})}{2 \times (7 \text{ ft})} \right)^4 \right] \right]$$

$$M_{max} = 0.069041 \text{ kipft}$$

Minimum Reinforcement Check (LRFD)

Parameters:

$f'_{ck} = 3 \text{ ksi}$ - Concrete strength,
 $f_{yk} = 60 \text{ ksi}$ - Longitudinal reinforcement strength,
 $\phi = 0.65$ - Reduction factor for axial strength,
 $\alpha = 0.8$ - Alpha factor for axial strength,
 $A_g = 2304 \text{ in}^2$ - Gross area of concrete,

Table 22.4.2.1

Longitudinal reinforcement:

Required reinforcement due to axial load, $A_{st,required}$

22.4.2.2, 10.6.1.1

$A_{st,required}$

$$A_{st,required} = \text{Min} \left[\frac{\frac{P}{\phi \alpha} - (0.85 f'_{ck} A_g)}{f_{yk} - (0.85 f'_{ck})}, (0.08 A_g) \right]$$

$$A_{st,required} = \text{Min} \left[\frac{\frac{(8.777 \text{ kip})}{(0.65) \times (0.8)} - (0.85 \times (3 \text{ ksi}) \times (2304 \text{ in}^2))}{(60 \text{ ksi}) - (0.85 \times (3 \text{ ksi}))}, (0.08 \times (2304 \text{ in}^2)) \right]$$

$$A_{st,required} = -101.97 \text{ in}^2$$

A_{min} - Governing minimum reinforcement area,

$$A_{min} = \text{Max} [A_{st,required}, (0.0018 A_g)]$$

$$A_{min} = \text{Max} [(-101.97 \text{ in}^2), (0.0018 \times (2304 \text{ in}^2))]$$

$$A_{min} = 4.1472 \text{ in}^2$$

n_{rebar} - Required number of reinforcement,

$$n_{rebar} = \frac{A_{min}}{A_{rebar}}$$

$$n_{rebar} = \frac{(4.1472 \text{ in}^2)}{(0.3068 \text{ in}^2)}$$

$$n_{rebar} = 14$$

A_{st} - Actual total reinforcement area,

$$A_{st} = n_{rebar} \frac{\pi d_{bar}^2}{4}$$

$$A_{st} = (14) \times \frac{\pi \times (0.625 \text{ in})^2}{4}$$

$$A_{st} = 4.2951 \text{ in}^2$$

Ratio - Capacity

$$\text{Ratio} = \frac{A_{min}}{A_{st}}$$

$$\text{Ratio} = \frac{(4.1472 \text{ in}^2)}{(4.2951 \text{ in}^2)}$$

$$\text{Ratio} = 0.96556$$

Status: **PASS**
Ratio: **0.970**

25.2.3

s_{rebar} - Minimum spacing of reinforcement,

$$s_{rebar} = \text{Max} [1.5, (1.5 d_{bar})]$$

$$s_{rebar} = \text{Max} [1.5, (1.5 \times (0.625 \text{ in}))]$$

$$s_{rebar} = 1.5 \text{ in}$$

Ties:

25.7.2.2

Since longitudinal reinforcement is \leq No. 10: Use #3(0.375 in)

25.7.2.1

s_{ties} - Maximum spacing of ties,

$$s_{ties} = \text{Min} [(16 d_{bar}), (48 d_{ties}), \text{Min} (D, b)]$$

$$s_{ties} = \text{Min} [(16 \times (0.625 \text{ in})), (48 \times (0.375 \text{ in})), \text{Min} ((48 \text{ in}), (48 \text{ in}))]$$

$$s_{ties} = 10 \text{ in}$$

Summary:

Main reinforcement: **14 - #5 (0.625 in)**

Ties: #3(0.375 in) - 10 in

Axial Compression Strength (ACI 318-19, LRFD)

22.4.2.2

ϕP_N - Allowable axial compressive strength

$$\phi P_N = \phi 0.80 [(0.85 f'_{ck} [A_g - A_{st}]) + (f_{yk} A_{st})]$$

$$\phi P_N = (0.65) \times 0.80 \times [(0.85 \times (3 \text{ ksi}) \times [(2304 \text{ in}^2) - (4.2951 \text{ in}^2)]) + ((60 \text{ ksi}) \times (4.2951 \text{ in}^2))]$$

$$\phi P_N = 3183.4 \text{ kip}$$

Ratio - Capacity

$$\text{Ratio} = \frac{P}{\phi P_N}$$

$$\text{Ratio} = \frac{(8.777 \text{ kip})}{(3183.4 \text{ kip})}$$

$$\text{Ratio} = 0.0027571$$

Status: **PASS**
Ratio: **0.000**

Shear Strength (ACI 318-19, LRFD)

Parameters:

22.5.2.2

$b_w = 48 \text{ in}$ - Effective width,
 d - Effective depth

$$d = 0.80 D$$

$$d = 0.80 \times (48 \text{ in})$$

$$d = 38.4 \text{ in}$$

22.5.5.1.3

λ_s - size effect modification factor

$$\lambda_s = \text{MIN} \left[\sqrt{\frac{2}{1 + \frac{d}{10}}}, 1 \right]$$

$$\lambda_s = \text{MIN} \left[\sqrt{\frac{2}{1 + \frac{(38.4 \text{ in})}{10}}}, 1 \right]$$

$$\lambda_s = 0.64282$$

22.5.5.1.1

The following variables were converted to be consistent with empirical formula $f'_{ck} = 3 \text{ ksi} \rightarrow 3000 \text{ psi}$,
 $V_{c,max}$ - Max shear strength of concrete

$$V_{c,max} = 5 \lambda_s \sqrt{f'_{ck}} b_w d$$

$$V_{c,max} = 5 \times (0.64282) \times \sqrt{(3000 \text{ psi})} \times (48 \text{ in}) \times (38.4 \text{ in})$$

$$V_{c,max} = 324.49 \text{ kip}$$

22.5.5.1.1(a)

The following variables were converted to be consistent with empirical formula $f'_{ck} = 3 \text{ ksi} \rightarrow 3000 \text{ psi}$, $P = 8.777 \text{ kip} \rightarrow 8777 \text{ lbf}$,
 $V_{c,a}$ - Shear strength of concrete (a)

$$V_{c,a} = \left[2 \lambda_s \sqrt{f'_{ck}} + \frac{P}{6 A_g} \right] b_w d$$

$$V_{c,a} = \left[2 \times (0.64282) \times \sqrt{(3000 \text{ psi})} + \frac{(8777 \text{ lbf})}{6 \times (2304 \text{ in}^2)} \right] \times (48 \text{ in}) \times (38.4 \text{ in})$$

$$V_{c,a} = 130.96 \text{ kip}$$

22.5.5.1.2

The following variables were converted to be consistent with empirical formula $f'_{ck} = 3 \text{ ksi} \rightarrow 3000 \text{ psi}$,
 $V_{c,b}$ - Shear strength of concrete (b)

$$V_{c,b} = \left[2 \lambda_s \sqrt{f'_{ck}} + (0.05 f'_{ck}) \right] b_w d$$

$$V_{c,b} = \left[2 \times (0.64282) \times \sqrt{(3000 \text{ psi})} + (0.05 \times (3000 \text{ psi})) \right] \times (48 \text{ in}) \times (38.4 \text{ in})$$

$$V_{c,b} = 406.27 \text{ kip}$$

V_c - Governing shear strength of concrete

$$V_c = \text{Min}[V_{c,max}, V_{c,a}, V_{c,b}]$$

$$V_c = \text{Min}[(324.49 \text{ kip}), (130.96 \text{ kip}), (406.27 \text{ kip})]$$

$$V_c = 130.96 \text{ kip}$$

<p>22.5.1.2</p>	<p>The following variables were converted to be consistent with empirical formula $f'_{ck} = 3 \text{ ksi} \rightarrow 3000 \text{ psi}$, $V_{s,a}$ - Shear strength of steel (a)</p> $V_{s,a} = 8 \sqrt{f'_{ck}} b_w d$ $V_{s,a} = 8 \times \sqrt{(3000 \text{ psi})} \times (48 \text{ in}) \times (38.4 \text{ in})$ $V_{s,a} = 807.65 \text{ kip}$ <p>A_v - Ties rebar area,</p> $A_v = \frac{\pi d_{ties}^2}{4}$ $A_v = \frac{\pi \times (0.375 \text{ in})^2}{4}$ $A_v = 0.11045 \text{ in}^2$ <p>22.5.8.5.3 $V_{s,b}$ - Shear strength of steel (b)</p> $V_{s,b} = \frac{2 A_v f_{yt} d}{s_{ties}}$ $V_{s,b} = \frac{2 \times (0.11045 \text{ in}^2) \times (60 \text{ ksi}) \times (38.4 \text{ in})}{(10 \text{ in})}$ $V_{s,b} = 50.894 \text{ kip}$ <p>V_s - Governing shear strength of steel</p> $V_s = \text{MIN}[V_{s,a}, V_{s,b}]$ $V_s = \text{MIN}[(807.65 \text{ kip}), (50.894 \text{ kip})]$ $V_s = 50.894 \text{ kip}$ <p>22.5.1.1 ϕV_n - Allowable shear strength</p> $\phi V_n = \phi (V_c + V_s)$ $\phi V_n = (0.65) \times ((130.96 \text{ kip}) + (50.894 \text{ kip}))$ $\phi V_n = 118.21 \text{ kip}$ <p>Considering x-direction:</p> <p>$V_{max} = 11.982 \text{ kip}$ - Maximum shear force in the x-direction, Ratio - Capacity</p> $\text{Ratio} = \frac{V_{max}}{\phi V_n}$ $\text{Ratio} = \frac{(11.982 \text{ kip})}{(118.21 \text{ kip})}$ $\text{Ratio} = 0.10136$ <p>Considering z-direction:</p> <p>$V_{max} = 0.022782 \text{ kip}$ - Maximum shear force in the z-direction, Ratio - Capacity</p> $\text{Ratio} = \frac{V_{max}}{\phi V_n}$ $\text{Ratio} = \frac{(0.022782 \text{ kip})}{(118.21 \text{ kip})}$ $\text{Ratio} = 0.00019273$	<p>Status: PASS Ratio: 0.100</p> <p>Status: PASS Ratio: 0.000</p>
	<p>Flexural Strength (ACI 318-19, LRFD)</p> <p>S_m - Section modulus</p> $S_m = \frac{b D^2}{6}$ $S_m = \frac{(48 \text{ in}) \times (48 \text{ in})^2}{6}$ $S_m = 18432 \text{ in}^3$	

<p>14.5.2.1b</p>	<p>$\lambda = 1$ - Concrete modification factor (Normal concrete), Allowable flexural strength: M_n shall be the lesser of: $\phi M_{n,1}$</p> $\phi M_{n,1} = \phi \times 5 \times \lambda \times \sqrt{f'_c} \times S_m$ $\phi M_{n,1} = 0.65 \times 5 \times 1 \times \sqrt{3\text{ksi}} \times 18432.001\text{in}^3$ $\phi M_{n,1} = 273.423\text{kipft}$ <p>$\phi M_{n,2}$</p> $\phi M_{n,2} = \phi \times 0.85 \times f'_c \times S_m$ $\phi M_{n,2} = (0.65) \times 0.85 \times (3\text{ksi}) \times (18432\text{in}^3)$ $\phi M_{n,2} = 2545.9\text{kipft}$ <p>Therefore, ϕM_n - Allowable flexural strength,</p> $\phi M_n = \text{MIN}[\phi M_{n,1}, \phi M_{n,2}]$ $\phi M_n = \text{MIN}[(273.42\text{kipft}), (2545.9\text{kipft})]$ $\phi M_n = 273.42\text{kipft}$ <p>Considering x-direction: $M_{max} = 39.689\text{kipft}$ - Maximum moment in the x-direction, Ratio - Capacity</p> $\text{Ratio} = \frac{M_{max}}{\phi M_n}$ $\text{Ratio} = \frac{(39.689\text{kipft})}{(273.42\text{kipft})}$ $\text{Ratio} = 0.14515$	<p>Status: PASS Ratio: 0.150</p>
	<p>Considering z-direction: $M_{max} = 0.069041\text{kipft}$ - Maximum moment in the z-direction, Ratio - Capacity</p> $\text{Ratio} = \frac{M_{max}}{\phi M_n}$ $\text{Ratio} = \frac{(0.069041\text{kipft})}{(273.42\text{kipft})}$ $\text{Ratio} = 0.00025251$	<p>Status: PASS Ratio: 0.000</p>