

# Your Project Calculations



Project Name: Sunup Solar Farm-TOP-8-CUA

S3D Model Link:  
[https://platform.skyciv.com/structural?preload\\_name=Sunup%20Solar%20Farm-TOP-8-CUA&preload\\_path=Shared%20Enterprise%20Folder/MT\\_Solar\\_Projects/1\\_2024](https://platform.skyciv.com/structural?preload_name=Sunup%20Solar%20Farm-TOP-8-CUA&preload_path=Shared%20Enterprise%20Folder/MT_Solar_Projects/1_2024)

Public Model Link:  
[https://platform.skyciv.com/structural-viewer?project\\_id=FIRO0MtpytAgGeIX3DyPXY7BsJKns5PfkI8olJvwAfaAwaMt6jv8qq8mpoD4MT](https://platform.skyciv.com/structural-viewer?project_id=FIRO0MtpytAgGeIX3DyPXY7BsJKns5PfkI8olJvwAfaAwaMt6jv8qq8mpoD4MT)

## Array Specification

Product:	Beam
Unique ID:	1P-0-8TOP-SD-45-L-4Hx2W-1CGD
Duty Classification:	SD
Module Width:	44.65 in
Module Length:	89.72in
Number of Rows:	4
Number of Columns:	2
Total Number of Modules:	8
Desired Tilt Angle:	60
Front Edge Clearance:	7
Total Array Height at Tilt:	19.96 ft
Total Frame Length:	15.00 ft
Frame Weight:	808 lbs
Array Dimensions N/S:	15.05 ft
Array Dimensions E/W:	15.12 ft
Rail Length:	180.60 in
Rail Spacing:	3.74 ft
Rail Check:	Not Checked

## Support Specifications

Pole Size:	8in Pipe Sch 40
Pole Length above Grade:	13.52 ft
Number of Poles:	1
Pole Spacing:	0

## Foundation Specifications

Foundation Type:	Square
Foundation Dimensions:	48 x 48 in
Foundation Depth (below grade):	Pile 1: 6.75 ft
Foundation Volume:	4.000 y <sup>3</sup>
Foundation Result:	PASSED
Mount Twist:	0.000004 kip

## Site Info

Risk Category:	I
Exposure:	B
Soil Classification:	sand
Site Location:	2222+22, Lastrup, MN, USA
Wind Speed:	110 mph
Snow Load:	60 psf
Design Uplift Pressure:	0.018899 ksf
Design Downforce Pressure:	-0.018899 ksf
Design Snow Pressure:	0.006598 ksf



### Design Disclaimer

This software should be used for preliminary designs and should not be used as a final design unless reviewed, verified and designed by a qualified structural engineer.

### AutoDesigner Input

```
{"product_type": "Beam", "project_id": "Sunup Solar Farm-TOP-8-CUA", "site_address": "2222+22, Lastrup, MN, USA", "module_width": 44.65, "module_length": 89.72, "number_rows": 4, "number_columns": 2, "pole_mount_section": "4_40", "core_pipe_width": 65, "core_pipe_section": "2_40", "adjuster_section": "2_40", "core_beam_height": 65, "core_beam_section": "HSS3x2x1/8", "main_pipe_section": "2_12GA", "pole_spacing": 15, "tilt_angle": 60, "ground_clearance": 7, "risk_category": "I", "exposure_category": "B", "frame_duty_override": "auto", "pole_override": "8_40", "soil_type": "sand", "customer_foundation_override": "48_Square", "foundation_type": "Square", "foundation_size": 48, "check_rails": false, "wind_speed_override": 110, "snow_load_override": 60, "direct_snow_load": false, "add_angle_brace": false}
```

### Design Notes:

- AISC Deflection checks are set to L/1 due to structure design intent
- Foundation Soil Parameters used in this Autodesign are all estimates, proper geotechnical reports are required to confirm soil profiles
- Wind speeds, snow loads and other site specific results are based on ASCE 7 2016
- Steel frame design checks are based on AISC 360 2016 (LRFD)
- Foundation Design and Sizing is approximate only



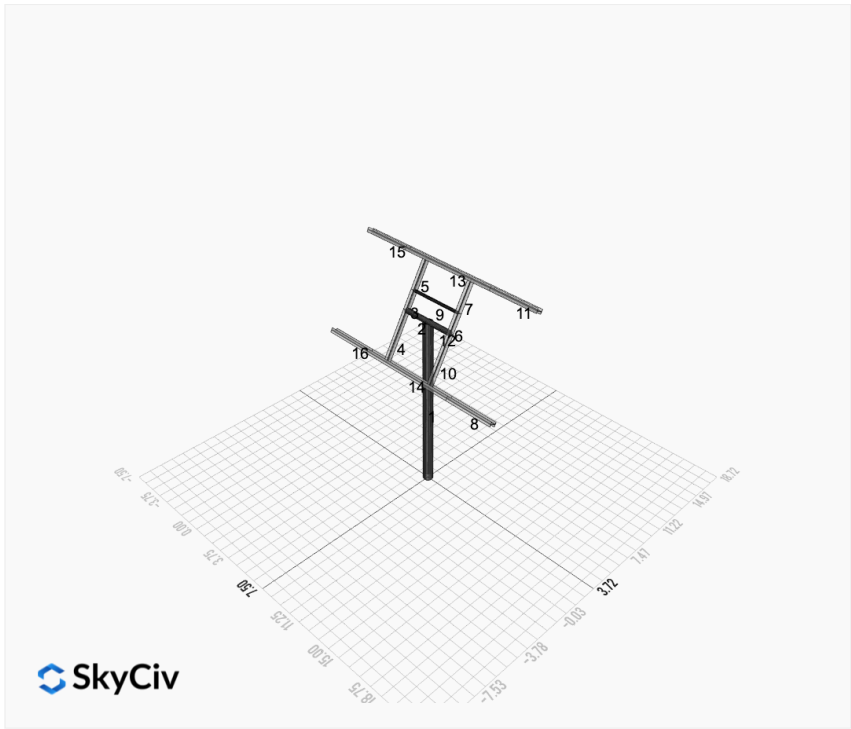
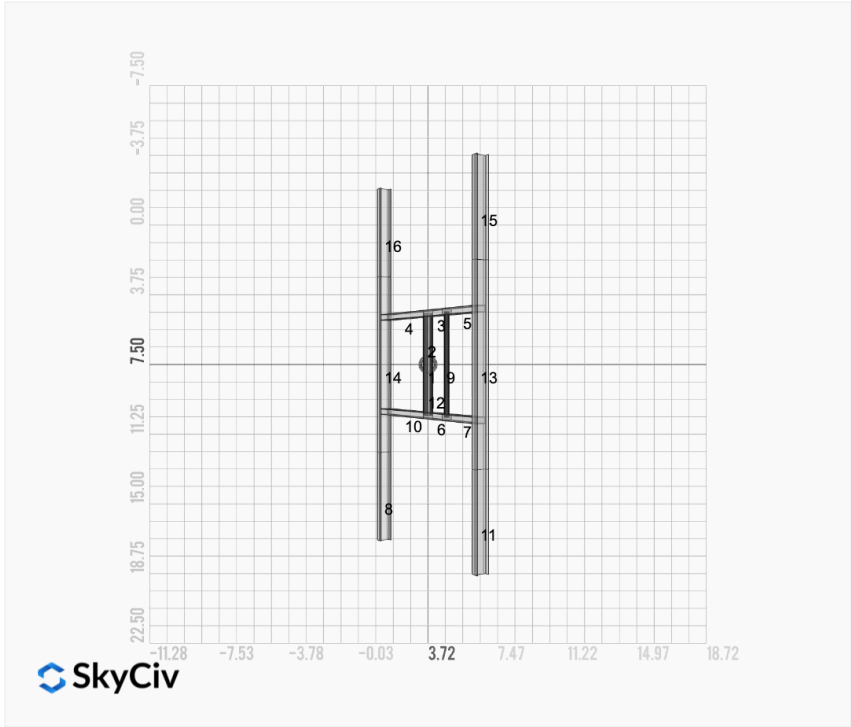

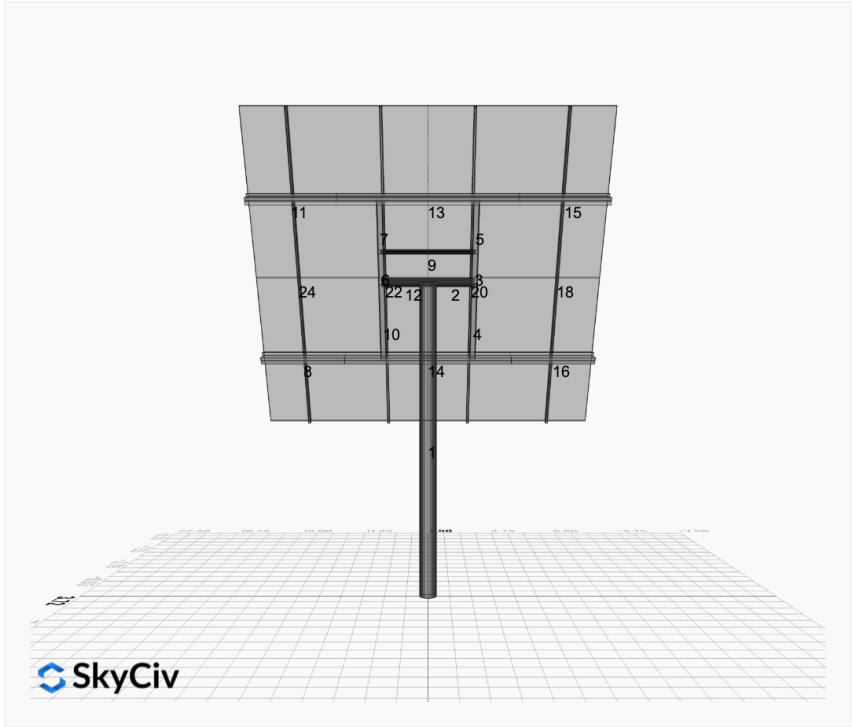

## FEM Results (Envelope Worst Case for each member)

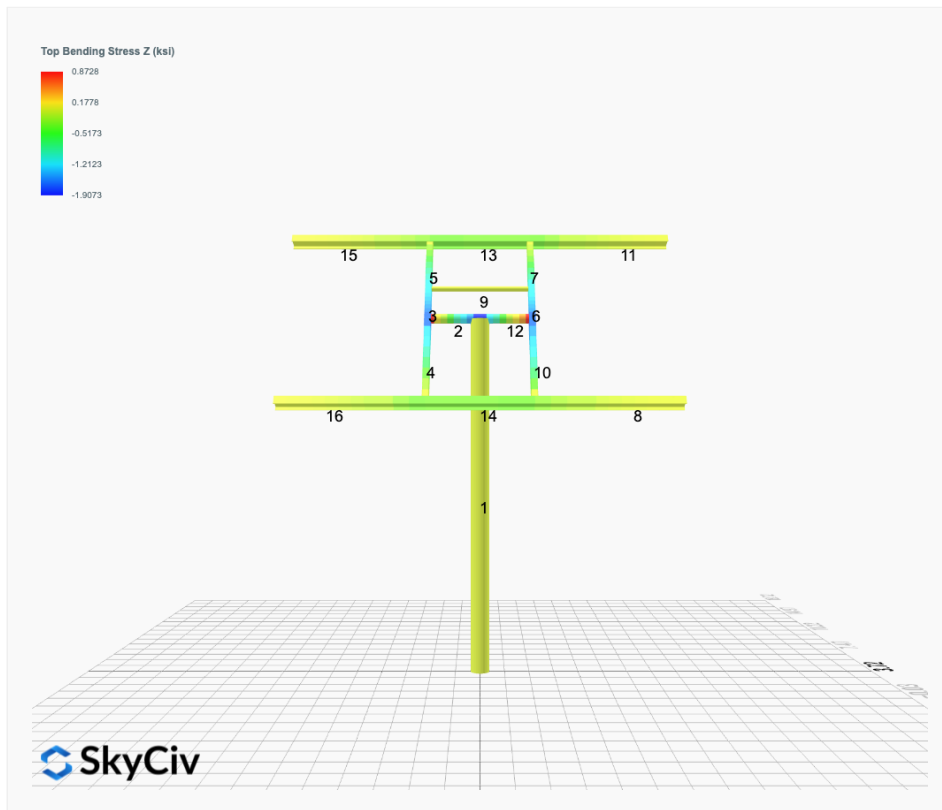
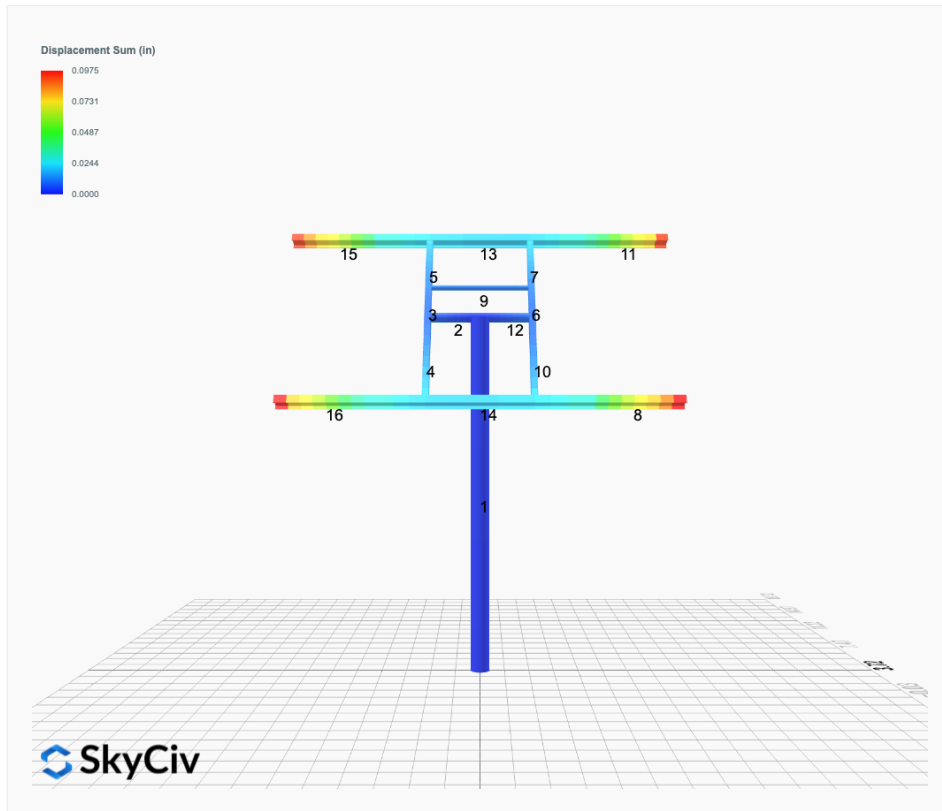

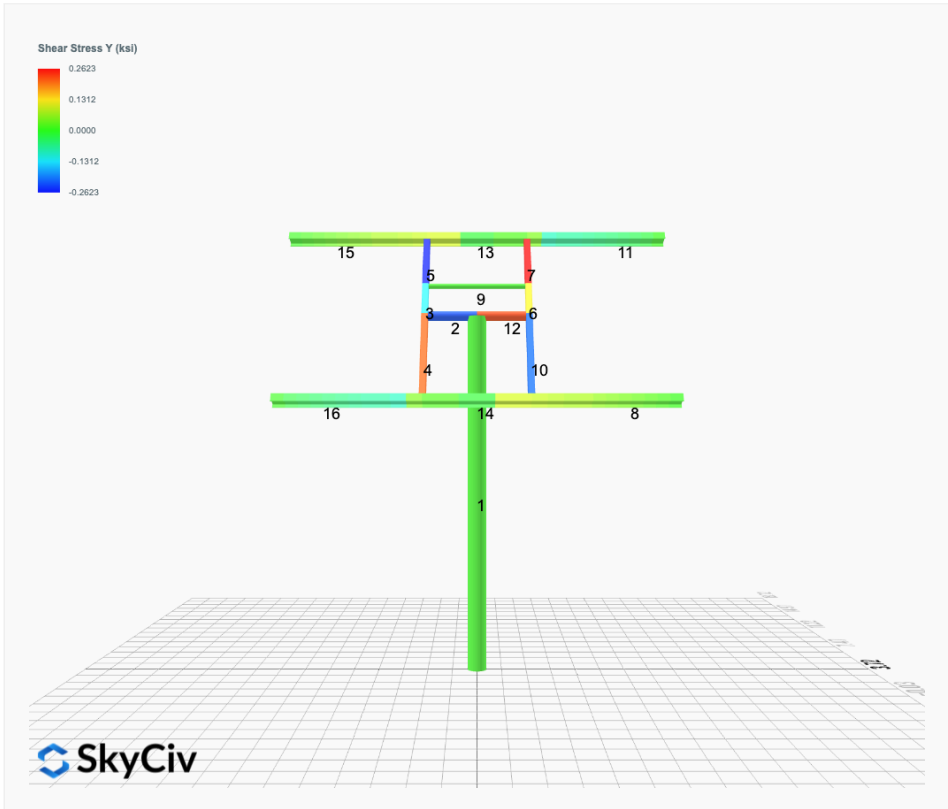
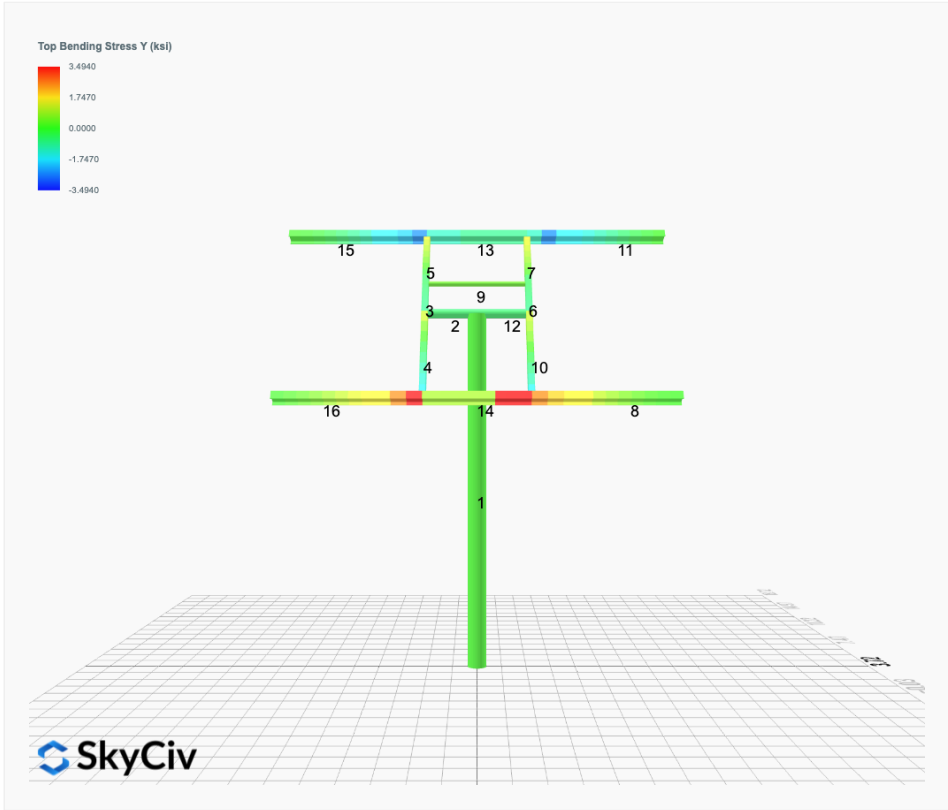

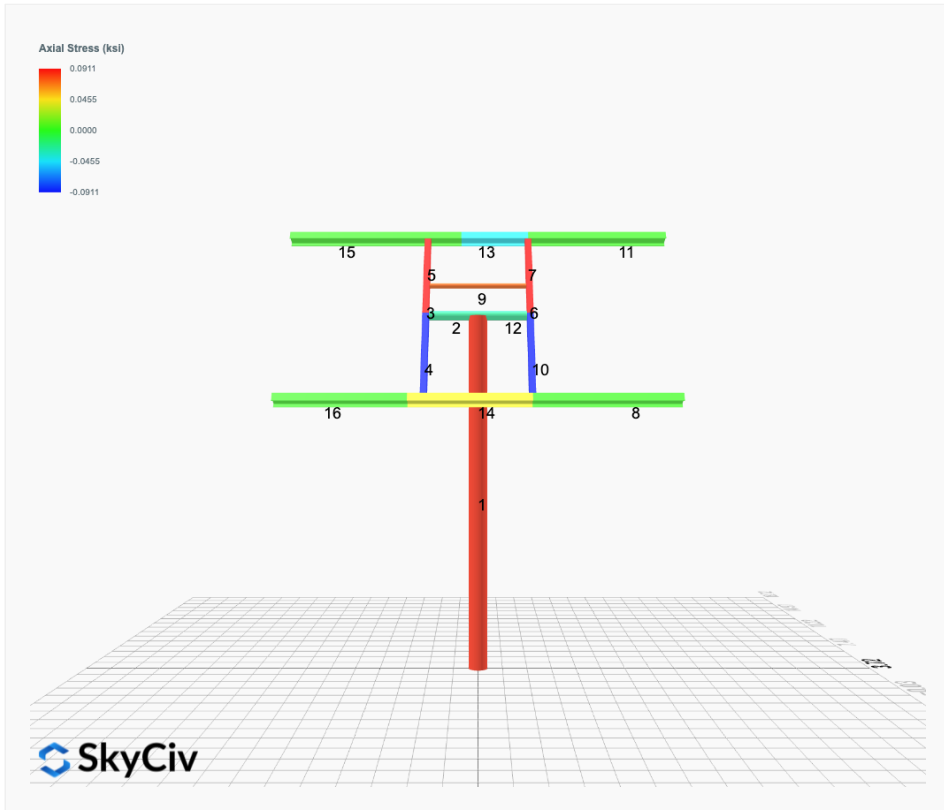

## Reaction Forces for Foundation 1 (Node ID#1), (kip, kip-ft)

### ASD Load Combination Results

Name	Fx	Fy	Fz	Mx	My	Mz
ULS: 1. D	0.0000	1.8383	0.0000	0.0000	-0.0000	0.0122
ULS: 2. D + L	0.0000	1.8383	0.0000	0.0000	-0.0000	0.0122
ULS: 3. D + (S or Lr or R)	0.0000	2.5830	0.0000	0.0000	-0.0000	0.0131
ULS: 3. D + (S or Lr or R)	0.0000	1.8383	0.0000	0.0000	-0.0000	0.0122
ULS: 4. D + 0.75L + 0.75(S or Lr or R)	0.0000	2.3968	0.0000	0.0000	-0.0000	0.0129
ULS: 4. D + 0.75L + 0.75(S or Lr or R)	0.0000	1.8383	0.0000	0.0000	-0.0000	0.0122
ULS: 5b. D + 0.7E	0.0000	1.8383	0.0000	0.0000	-0.0000	0.0122
ULS: 6b. D + 0.75L + 0.75(0.7)E + 0.75S	0.0000	2.3968	0.0000	0.0000	-0.0000	0.0129
ULS: 8. 0.6D + 0.7E	0.0000	1.1030	0.0000	0.0000	-0.0000	0.0073
ULS: 5a. D + 0.6W_Wind downforce Case A only	-2.2346	3.1284	0.0000	0.0000	-0.0000	30.4907
ULS: 5a. D + 0.6W_Wind downforce Case B only	0.0000	1.8383	0.0000	0.0000	-0.0000	0.0122
ULS: 5a. D + 0.6W_Wind uplift Case A only	2.2346	0.5482	0.0000	0.0000	-0.0000	-29.9243
ULS: 5a. D + 0.6W_Wind uplift Case B only	0.0000	1.8383	0.0000	0.0000	-0.0000	0.0122
ULS: 6a. D + 0.75L + 0.75(0.6)W + 0.75(S or Lr or R)_Wind downforce Case A only	-1.6759	3.3645	0.0000	0.0000	-0.0000	22.8718
ULS: 6a. D + 0.75L + 0.75(0.6)W + 0.75(S or Lr or R)_Wind downforce Case B only	0.0000	2.3968	0.0000	0.0000	-0.0000	0.0129
ULS: 6a. D + 0.75L + 0.75(0.6)W + 0.75(S or Lr or R)_Wind uplift Case A only	1.6759	1.4292	0.0000	0.0000	-0.0000	-22.4395
ULS: 6a. D + 0.75L + 0.75(0.6)W + 0.75(S or Lr or R)_Wind uplift Case B only	0.0000	2.3968	0.0000	0.0000	-0.0000	0.0129
ULS: 6a. D + 0.75L + 0.75(0.6)W + 0.75(S or Lr or R)_Wind downforce Case A only	-1.6759	2.8059	0.0000	0.0000	-0.0000	22.8711
ULS: 6a. D + 0.75L + 0.75(0.6)W + 0.75(S or Lr or R)_Wind downforce Case B only	0.0000	1.8383	0.0000	0.0000	-0.0000	0.0122
ULS: 6a. D + 0.75L + 0.75(0.6)W + 0.75(S or Lr or R)_Wind uplift Case A only	1.6759	0.8707	0.0000	0.0000	-0.0000	-22.4402
ULS: 6a. D + 0.75L + 0.75(0.6)W + 0.75(S or Lr or R)_Wind uplift Case B only	0.0000	1.8383	0.0000	0.0000	-0.0000	0.0122
ULS: 7. 0.6D + 0.6W_Wind downforce Case A only	-2.2346	2.3931	0.0000	0.0000	-0.0000	30.4859
ULS: 7. 0.6D + 0.6W_Wind downforce Case B only	0.0000	1.1030	0.0000	0.0000	-0.0000	0.0073
ULS: 7. 0.6D + 0.6W_Wind uplift Case A only	2.2346	-0.1872	0.0000	0.0000	-0.0000	-29.9292
ULS: 7. 0.6D + 0.6W_Wind uplift Case B only	0.0000	1.1030	0.0000	0.0000	-0.0000	0.0073

### Worst Case Reactions LRFD

These calculations are taken directly from the FEA via SkyCiv and are used in the Concrete Checks of the Foundation Module.  
Note: Worst case values are assumed as downforce wind load cases.

Result	Value (kip, kip-ft)
Axial	4.7286
Shear X	-3.7243
Shear Z	0.0000
Moment X	0.0000
Moment Y (Twist)	0.0000
Moment Z	51.4057

### Worst Case Reactions ASD

These results are taken from the worst case values in the above table and are used in the Soil Checks in the Foundation Module.  
Note: Worst case values are assumed as downforce wind load cases.

Result	Value (kip, kip-ft)
Axial	3.3645
Shear X	-2.2346
Shear Z	0.0000
Moment X	0.0000
Moment Y (Twist)	0.0000
Moment Z	30.4907

## Project Details

Design Code: AISC 360-16 LRFD  
 Provision: LRFD  
 Country: United States  
 User Name: sales@mtsolar.us  
 Unit System: imperial



## Design Input Information

Design Factors			
$\Phi_t$	$\Phi_c$	$\Phi_b$	$\Phi_v$
0.9	0.9	0.9	0.9

Design Materials			
ID	E (ksi)	$F_y$ (ksi)	$F_u$ (ksi)
1	29000	50	65

### Section Dimensions



ID	Name	d (in)	$t_w$ (in)				
1	2in Pipe Sch 40	2.38	0.15				
4	4in Pipe Sch 40	4.50	0.24				
9	8in Pipe Sch 40	8.63	0.32				

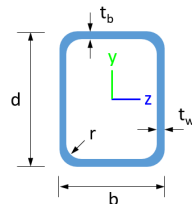

ID	Name	d (in)	b (in)	$t_w$ (in)	$t_b$ (in)	r (in)	
15	HSS5x3x1/8	5.00	3.00	0.12	0.12	0.12	



ID	Name	d (in)	$t_w$ (in)	$b_t$ (in)	$b_b$ (in)	$t_t$ (in)	$t_b$ (in)	r (in)
18	W6x9	5.90	0.17	3.94	3.94	0.21	0.21	0.25

### Section Properties

ID	Name	A (in <sup>2</sup> )	J (in <sup>4</sup> )	$I_{yp}$ (in <sup>4</sup> )	$I_{zp}$ (in <sup>4</sup> )	$I_w$ (in <sup>6</sup> )	$S_{yp}$ (in <sup>3</sup> )	$S_{zp}$ (in <sup>3</sup> )
1	2in Pipe Sch 40	1.07	1.33	0.67	0.67	0.00	0.76	0.76
4	4in Pipe Sch 40	3.17	14.47	7.23	7.23	0.00	4.31	4.31
9	8in Pipe Sch 40	8.40	144.98	72.49	72.49	0.00	22.21	22.21



11	120.60	54.44	23.36	6.45	30.09	45.74
12	142.83	141.72	16.17	16.17	42.85	42.85
13	120.60	98.23	18.35	6.45	30.09	45.74
14	120.60	98.23	18.33	6.45	30.09	45.74
15	120.60	54.44	23.36	6.45	30.09	45.74
16	120.60	54.44	23.36	6.45	30.09	45.74

## Design Ratio

Member ID	P	M <sub>z</sub>	M <sub>y</sub>	V <sub>y</sub>	V <sub>z</sub>	(P,M <sub>z</sub> ,M <sub>y</sub> )	Worst LC	KL/r	δ	Status
1	0.034	0.617	0.000	0.033	0.000	0.634	#13	0.580	Not Required	Pass
2	0.002	0.210	0.227	0.050	0.043	0.438	#13	0.034	Not Required	Pass
3	0.008	0.457	0.085	0.046	0.009	0.521	#13	0.044	Not Required	Pass
4	0.008	0.455	0.180	0.046	0.023	0.547	#13	0.078	Not Required	Pass
5	0.008	0.283	0.186	0.045	0.027	0.314	#13	0.073	Not Required	Pass
6	0.008	0.457	0.085	0.046	0.009	0.521	#13	0.044	Not Required	Pass
7	0.008	0.283	0.186	0.045	0.027	0.314	#13	0.073	Not Required	Pass
8	0.000	0.053	0.087	0.022	0.007	0.122	#21	Not Required	Not Required	Pass
9	0.007	0.023	0.047	0.001	0.000	0.073	#13	0.198	Not Required	Pass
10	0.008	0.455	0.180	0.046	0.023	0.547	#13	0.078	Not Required	Pass
11	0.000	0.053	0.087	0.022	0.007	0.122	#21	Not Required	Not Required	Pass
12	0.002	0.210	0.227	0.050	0.043	0.438	#13	0.034	Not Required	Pass
13	0.004	0.152	0.187	0.032	0.010	0.284	#21	0.177	Not Required	Pass
14	0.004	0.155	0.187	0.032	0.010	0.284	#21	0.177	Not Required	Pass
15	0.000	0.053	0.087	0.022	0.007	0.122	#21	Not Required	Not Required	Pass
16	0.000	0.053	0.087	0.022	0.007	0.122	#21	Not Required	Not Required	Pass

## Definitions

$\Phi_t$	Safety factor for tensile
$\Phi_c$	Safety factor for compression
$\Phi_b$	Safety factor for flexure
$\Phi_v$	Safety factor for shear
E	Modulus of elasticity
F <sub>y</sub>	Specified minimum yield stress
F <sub>u</sub>	Specified minimum tensile strength
A	Cross-sectional area
J	Torsional constant
I <sub>yp</sub>	Moment of inertia about the Y axes
I <sub>zp</sub>	Moment of inertia about the Z axes
I <sub>w</sub>	Warping constant
S <sub>yp</sub>	Plastic section modulus about the Y axis
S <sub>zp</sub>	Plastic section modulus about the Z axis
KL	Effective length
C <sub>b</sub>	Buckling modification factor (from all load combinations)
L <sub>b</sub>	Length between braced points
LST	Limited slenderness for tension
LSC	Limited slenderness for compression
LD	Limited deflection
P <sub>n</sub>	Nominal axial strength (tension/compression)
M <sub>n</sub>	Nominal flexural strength (about Z/Y axis)
V <sub>n</sub>	Nominal shear strength (along Z/Y axis)
P	Design ratio in case of axial force
M <sub>z</sub>	Design ratio in case of bending about Z axis
M <sub>y</sub>	Design ratio in case of bending about Y axis
V <sub>y</sub>	Design ratio in case of shear along Y axis
V <sub>z</sub>	Design ratio in case of shear along Z axis
(P,M <sub>z</sub> ,M <sub>y</sub> )	Design ratio in case of axial force and bending action
KL/r	Design ratio in case of section slenderness
δ	Design ratio in case of member deflection
OK	Capacity is provided
NG	Capacity is not provided

Capacity is not provided

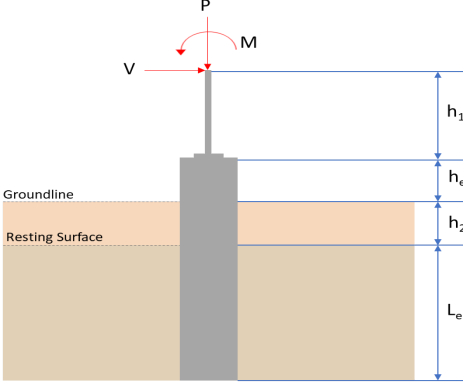
REFERENCES	CALCULATIONS	RESULTS																										
	<p><b>SkyCiv Foundation Design</b> Pile Foundation</p> <p><b>Design Information :</b> Design code : IBC 2021 (International Building Code) Unit System : Imperial</p>																											
	<p><b>Pile Input</b></p>  <p><b>Geometry</b> Pile shape: rectangular <math>b = 48</math> in - Pile width <math>D = 48</math> in - Pile depth <math>L = 6.75</math> ft - Total pile length <math>h_1 = 0</math> ft - Lateral load height from the top of the pile, <math>h_2 = 0</math> ft - Depth to resting surface <math>h_e = 0</math> ft - Length of pile above the ground</p> <p><b>Tabulation of Soil Parameters</b></p> <table border="1" data-bbox="416 1102 1192 1191"> <thead> <tr> <th>Layer</th> <th>Label</th> <th>Allowable Bearing Pressure (<math>q_a</math>) (psf)</th> <th>Allowable Lateral Pressure (<math>R</math>) (psf/ft)</th> </tr> </thead> <tbody> <tr> <td>1</td> <td>Sand, silty sand, clayey sand, silty gravel &amp; clayey gravel</td> <td>2000.000</td> <td>150.000</td> </tr> </tbody> </table> <p><b>Tabulation of Loads</b></p> <table border="1" data-bbox="676 1288 933 1458"> <thead> <tr> <th>Load Component</th> <th>ASD</th> <th>LRFD</th> </tr> </thead> <tbody> <tr> <td><math>P</math> (kip)</td> <td>3.364</td> <td>4.729</td> </tr> <tr> <td><math>V_x</math> (kip)</td> <td>-2.235</td> <td>-3.724</td> </tr> <tr> <td><math>V_z</math> (kip)</td> <td>0.000</td> <td>0.000</td> </tr> <tr> <td><math>M_x</math> (kipft)</td> <td>0.000</td> <td>0.000</td> </tr> <tr> <td><math>M_z</math> (kipft)</td> <td>30.491</td> <td>51.406</td> </tr> </tbody> </table> <p><b>Material Properties</b> <math>f'_{ck} = 2.5</math> ksi - Concrete strength,</p>	Layer	Label	Allowable Bearing Pressure ( $q_a$ ) (psf)	Allowable Lateral Pressure ( $R$ ) (psf/ft)	1	Sand, silty sand, clayey sand, silty gravel & clayey gravel	2000.000	150.000	Load Component	ASD	LRFD	$P$ (kip)	3.364	4.729	$V_x$ (kip)	-2.235	-3.724	$V_z$ (kip)	0.000	0.000	$M_x$ (kipft)	0.000	0.000	$M_z$ (kipft)	30.491	51.406	
Layer	Label	Allowable Bearing Pressure ( $q_a$ ) (psf)	Allowable Lateral Pressure ( $R$ ) (psf/ft)																									
1	Sand, silty sand, clayey sand, silty gravel & clayey gravel	2000.000	150.000																									
Load Component	ASD	LRFD																										
$P$ (kip)	3.364	4.729																										
$V_x$ (kip)	-2.235	-3.724																										
$V_z$ (kip)	0.000	0.000																										
$M_x$ (kipft)	0.000	0.000																										
$M_z$ (kipft)	30.491	51.406																										
	<p><b>Required depth to resist lateral loads (ASD)</b> <math>H</math> - Point of application of the lateral load</p> $H = h_1 + h_2 + h_e$ $H = (0 \text{ ft}) + (0 \text{ ft}) + (0 \text{ ft})$ $H = 0 \text{ ft}$ <p><b>Considering x-direction:</b> <math>H_o</math> - Lateral force per length of pile,</p> $H_o = \frac{V_x}{1.57 D}$ $H_o = \frac{(-2.235 \text{ kip})}{1.57 \times (48 \text{ in})}$ $H_o = -0.35589 \text{ kip/ft}$ <p><math>M_o</math> - Moment per length of pile,</p> $M_o = \frac{M_z + (V_x H)}{1.57 D}$																											

	$M_o = \frac{(30.491 \text{ kipft}) + ((-2.235 \text{ kip}) \times (0 \text{ ft}))}{1.57 \times (48 \text{ in})}$ $M_o = 4.8553 \text{ kipft/ft}$ <p>Required depth of embedment in earth:</p> $L_x^3 - \left(14.14 \times \frac{H_o \times L_x}{R}\right) - \left(18.85 \times \frac{M_o}{R}\right) = 0$ <p>Solving the cubic equation:  <math>L_{e,x} = 6.3273 \text{ ft}</math> - Required depth in x-direction,</p> <p><b>Considering z-direction:</b>  <math>L_{e,z} = 0 \text{ ft}</math> - Required depth in z-direction,</p> <p><b>Minimum embedded depth required:</b>  <math>L_{e,req}</math> - Depth of pile required,</p> $L_{e,req} = \text{MAX}[L_{e,x}, L_{e,z}]$ $L_{e,req} = \text{MAX}[(6.3273 \text{ ft}), (0 \text{ ft})]$ $L_{e,req} = 6.327 \text{ ft}$ <p><math>L_e</math> - Actual embedded length of pile,</p> $L_e = L - h_e - h_2$ $L_e = (6.75 \text{ ft}) - (0 \text{ ft}) - (0 \text{ ft})$ $L_e = 6.75 \text{ ft}$ <p><b>Ratio</b> - Embedded depth</p> $\text{Ratio} = \frac{L_{e,req}}{L_e}$ $\text{Ratio} = \frac{(6.327 \text{ ft})}{(6.75 \text{ ft})}$ $\text{Ratio} = 0.93733$	<p>Status: <b>PASS</b>  Ratio: <b>0.940</b></p>
	<p><b>End-bearing Capacity (ASD)</b>  A - Pile cross-section area</p> $A = b D$ $A = (48 \text{ in}) \times (48 \text{ in})$ $A = 16 \text{ ft}^2$ <p>q - End-bearing pressure</p> $q = \frac{P_v}{A}$ $q = \frac{(3.364 \text{ kip})}{(16 \text{ ft}^2)}$ $q = 0.21025 \text{ kip/ft}^2$ <p><b>Check bearing capacity ratio:</b>  Ratio - Capacity</p> $\text{Ratio} = \frac{q}{q_o}$ $\text{Ratio} = \frac{(0.21025 \text{ kip/ft}^2)}{(2000 \text{ psf})}$ $\text{Ratio} = 0.10512$	<p>Status: <b>PASS</b>  Ratio: <b>0.110</b></p>
Czerniak	<p><b>Lateral Soil Pressure (ASD):</b>  L/D - Length to least lateral dimension ratio,</p> $L/D = \frac{L}{D}$ $L/D = \frac{(6.75 \text{ ft})}{(48 \text{ in})}$	

$$L/D = 1.6875$$

Since  $L/D \leq 10$ ,

Pile is short.

**Considering x-direction:**

$H_o = -0.35589$  kip/ft - Lateral force per length of pile,

$M_o = 4.8553$  kipft/ft - Overturning moment per length of pile,

$a$  - Distance from resting surface to pivot point,

$$a = \frac{(4 M_o L_e) + (3 H_o L_e^2)}{(6 M_o) + (4 H_o L_e)}$$

$$a = \frac{(4 \times (4.8553 \text{ kipft/ft}) \times (6.75 \text{ ft})) + (3 \times (-0.35589 \text{ kip/ft}) \times (6.75 \text{ ft})^2)}{(6 \times (4.8553 \text{ kipft/ft})) + (4 \times (-0.35589 \text{ kip/ft}) \times (6.75 \text{ ft}))}$$

$$a = 4.6395 \text{ ft}$$

$p$  - Earth pressure against the pile at distance  $a/2$  from resting surface,

$$p = \frac{0.75 [(4 M_o) + (3 H_o L_e)]^2}{L_e^2 [(3 M_o) + (2 H_o L_e)]}$$

$$p = \frac{0.75 \times [(4 \times (4.8553 \text{ kipft/ft})) + (3 \times (-0.35589 \text{ kip/ft}) \times (6.75 \text{ ft}))]^2}{(6.75 \text{ ft})^2 \times [(3 \times (4.8553 \text{ kipft/ft})) + (2 \times (-0.35589 \text{ kip/ft}) \times (6.75 \text{ ft}))]}$$

$$p = 0.25158 \text{ kip/ft}^2$$

$s$  - Earth pressure against the pile at distance  $L_e$ ,

$$s = \frac{6 [(2 M_o) + (H_o L_e)]}{L_e^2}$$

$$s = \frac{6 \times [(2 \times (4.8553 \text{ kipft/ft})) + ((-0.35589 \text{ kip/ft}) \times (6.75 \text{ ft}))]}{(6.75 \text{ ft})^2}$$

$$s = 0.9624 \text{ kip/ft}^2$$

**Check lateral soil pressure capacity:**

$p_a$  - Allowable lateral soil pressure at depth  $a/2$ ,

$$p_a = R \frac{q}{2}$$

$$p_a = (150 \text{ psf/ft}) \times \frac{(4.6395 \text{ ft})}{2}$$

$$p_a = 0.34796 \text{ kip/ft}^2$$

*Ratio* - Lateral soil capacity

$$\text{Ratio} = \frac{p}{p_a}$$

$$\text{Ratio} = \frac{(0.25158 \text{ kip/ft}^2)}{(0.34796 \text{ kip/ft}^2)}$$

$$\text{Ratio} = 0.72301$$

$p_s$  - Allowable lateral soil pressure at depth  $L_e$ ,

$$p_s = R L_e$$

$$p_s = (150 \text{ psf/ft}) \times (6.75 \text{ ft})$$

$$p_s = 1.0125 \text{ kip/ft}^2$$

*Ratio* - Lateral soil capacity

$$\text{Ratio} = \frac{s}{p_s}$$

$$\text{Ratio} = \frac{(0.9624 \text{ kip/ft}^2)}{(1.0125 \text{ kip/ft}^2)}$$

$$\text{Ratio} = 0.95052$$

Status: **PASS**  
Ratio: **0.720**

Status: **PASS**  
Ratio: **0.950**

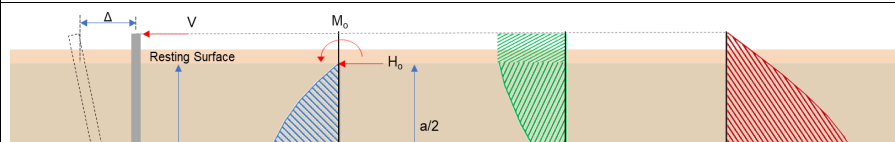

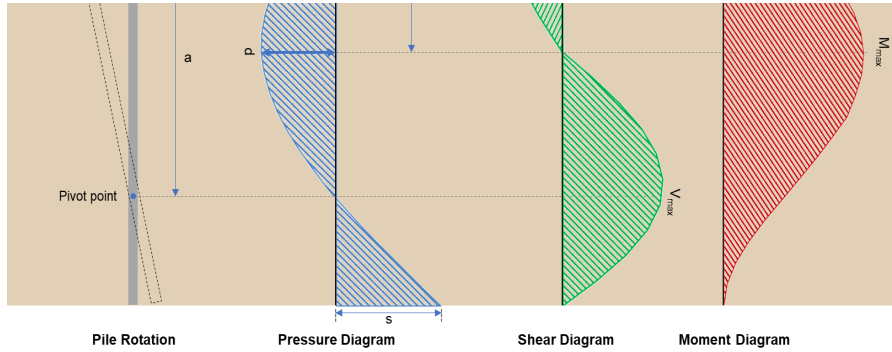

### Shear force and Bending moment (x-direction, LRFD)

$H_o$  - Lateral force per length of pile,

$$H_o = \frac{V_x}{1.57 D}$$

$$H_o = \frac{(-3.724 \text{ kip})}{1.57 \times (48 \text{ in})}$$

$$H_o = -0.593 \text{ kip/ft}$$

$M_o$  - Moment per length of pile,

$$M_o = \frac{M_x + (V_x H)}{1.57 D}$$

$$M_o = \frac{(51.406 \text{ kipft}) + ((-3.724 \text{ kip}) \times (0 \text{ ft}))}{1.57 \times (48 \text{ in})}$$

$$M_o = 8.1857 \text{ kipft/ft}$$

$E$  - Distance from lateral load to resisting surface,

$$E = \frac{M_o}{H_o}$$

$$E = \frac{(8.1857 \text{ kipft/ft})}{(-0.593 \text{ kip/ft})}$$

$$E = 13.804 \text{ ft}$$

$a$  - Distance from resting surface to pivot point,

$$a = \frac{(4 M_o L_c) + (3 H_o L_c^2)}{(6 M_o) + (4 H_o L_c)}$$

$$a = \frac{(4 \times (8.1857 \text{ kipft/ft}) \times (6.75 \text{ ft})) + (3 \times (-0.593 \text{ kip/ft}) \times (6.75 \text{ ft})^2)}{(6 \times (8.1857 \text{ kipft/ft})) + (4 \times (-0.593 \text{ kip/ft}) \times (6.75 \text{ ft}))}$$

$$a = 4.6383 \text{ ft}$$

$V_{max}$  - Max shear force located at depth  $a$ ,

$$V_{max} = (H_o D) \left[ 1 - \left[ 3 \left( \frac{4 E}{L_c} + 3 \right) \left( \frac{a}{L_c} \right)^2 \right] + \left[ 4 \left( \frac{3 E}{L_c} + 2 \right) \left( \frac{a}{L_c} \right)^3 \right] \right]$$

$$V_{max} = ((-0.593 \text{ kip/ft}) \times (48 \text{ in})) \times \left[ 1 - \left[ 3 \times \left( \frac{4 \times (13.804 \text{ ft})}{(6.75 \text{ ft})} + 3 \right) \times \left( \frac{(4.6383 \text{ ft})}{(6.75 \text{ ft})} \right)^2 \right] + \left[ 4 \times \left( \frac{3 \times (13.804 \text{ ft})}{(6.75 \text{ ft})} + 2 \right) \times \left( \frac{(4.6383 \text{ ft})}{(6.75 \text{ ft})} \right)^3 \right] \right]$$

$$V_{max} = 10.15 \text{ kip}$$

$M_{max}$  - Max bending moment located at depth  $a/2$ ,

$$M_{max} = (H_o D L_c) \left[ \left( \frac{E}{L_c} + \frac{a}{2 L_c} \right) - \left[ \left( \frac{4 E}{L_c} + 3 \right) \left( \frac{a}{2 L_c} \right)^3 \right] + \left[ \left( \frac{3 E}{L_c} + 2 \right) \left( \frac{a}{2 L_c} \right)^4 \right] \right]$$

$$M_{max} = ((-0.593 \text{ kip/ft}) \times (48 \text{ in}) \times (6.75 \text{ ft})) \times \left[ \left( \frac{(13.804 \text{ ft})}{(6.75 \text{ ft})} + \frac{(4.6383 \text{ ft})}{2 \times (6.75 \text{ ft})} \right) - \left[ \left( \frac{4 \times (13.804 \text{ ft})}{(6.75 \text{ ft})} + 3 \right) \times \left( \frac{(4.6383 \text{ ft})}{2 \times (6.75 \text{ ft})} \right)^3 \right] + \left[ \left( \frac{3 \times (13.804 \text{ ft})}{(6.75 \text{ ft})} + 2 \right) \times \left( \frac{(4.6383 \text{ ft})}{2 \times (6.75 \text{ ft})} \right)^4 \right] \right]$$

$$M_{max} = 32.799 \text{ kipft}$$

### Minimum Reinforcement Check (LRFD)

#### Parameters:

$f'_{ck} = 2.5 \text{ ksi}$  - Concrete strength,  
 $f_{yk} = 60 \text{ ksi}$  - Longitudinal reinforcement strength,  
 $\phi = 0.65$  - Reduction factor for axial strength,  
 $\alpha = 0.8$  - Alpha factor for axial strength,  
 $A_g = 2304 \text{ in}^2$  - Gross area of concrete,

Table 22.4.2.1

#### Longitudinal reinforcement:

Required reinforcement due to axial load,  $A_{st,required}$

22.4.2.2, 10.6.1.1

$A_{st,required}$

$$A_{st,required} = \text{Min} \left[ \frac{\frac{P}{\phi \alpha} - (0.85 f'_{ck} A_g)}{f_{yk} - (0.85 f'_{ck})}, (0.08 A_g) \right]$$

$$A_{st,required} = \text{Min} \left[ \frac{\frac{(4.729 \text{ kip})}{(0.65) \times (0.8)} - (0.85 \times (2.5 \text{ ksi}) \times (2304 \text{ in}^2))}{(60 \text{ ksi}) - (0.85 \times (2.5 \text{ ksi}))}, (0.08 \times (2304 \text{ in}^2)) \right]$$

$$A_{st,required} = -84.439 \text{ in}^2$$

$A_{min}$  - Governing minimum reinforcement area,

$$A_{min} = \text{Max} [A_{st,required}, (0.0018 A_g)]$$

$$A_{min} = \text{Max} [(-84.439 \text{ in}^2), (0.0018 \times (2304 \text{ in}^2))]$$

$$A_{min} = 4.1472 \text{ in}^2$$

$n_{rebar}$  - Required number of reinforcement,

$$n_{rebar} = \frac{A_{min}}{A_{rebar}}$$

$$n_{rebar} = \frac{(4.1472 \text{ in}^2)}{(0.3068 \text{ in}^2)}$$

$$n_{rebar} = 14$$

$A_{st}$  - Actual total reinforcement area,

$$A_{st} = n_{rebar} \frac{\pi d_{bar}^2}{4}$$

$$A_{st} = (14) \times \frac{\pi \times (0.625 \text{ in})^2}{4}$$

$$A_{st} = 4.2951 \text{ in}^2$$

Ratio - Capacity

$$\text{Ratio} = \frac{A_{min}}{A_{st}}$$

$$\text{Ratio} = \frac{(4.1472 \text{ in}^2)}{(4.2951 \text{ in}^2)}$$

$$\text{Ratio} = 0.96556$$

Status: **PASS**  
Ratio: **0.970**

25.2.3

$s_{rebar}$  - Minimum spacing of reinforcement,

$$s_{rebar} = \text{Max} [1.5, (1.5 d_{bar})]$$

$$s_{rebar} = \text{Max} [1.5, (1.5 \times (0.625 \text{ in}))]$$

$$s_{rebar} = 1.5 \text{ in}$$

#### Ties:

25.7.2.2 Since longitudinal reinforcement is  $\leq$  No. 10: Use #3(0.375 in)

25.7.2.1

$s_{ties}$  - Maximum spacing of ties,

$$s_{ties} = \text{Min} [(16 d_{bar}), (48 d_{ties}), \text{Min} (D, b)]$$

$$s_{ties} = \text{Min} [(16 \times (0.625 \text{ in})), (48 \times (0.375 \text{ in})), \text{Min} ((48 \text{ in}), (48 \text{ in}))]$$

$$s_{ties} = 10 \text{ in}$$

#### Summary:

Main reinforcement: **14 - #5 (0.625 in)**

**Axial Compression Strength (ACI 318-19, LRFD)**22.4.2.2  $\phi P_N$  - Allowable axial compressive strength

$$\phi P_N = \phi 0.80 [(0.85 f'_{ck} [A_g - A_{st}]) + (f_{yt} A_{st})]$$

$$\phi P_N = (0.65) \times 0.80 \times [(0.85 \times (2.5 \text{ ksi}) \times [(2304 \text{ in}^2) - (4.2951 \text{ in}^2)]) + ((60 \text{ ksi}) \times (4.2951 \text{ in}^2))]$$

$$\phi P_N = 2675.2 \text{ kip}$$

Ratio - Capacity

$$\text{Ratio} = \frac{P}{\phi P_N}$$

$$\text{Ratio} = \frac{(4.729 \text{ kip})}{(2675.2 \text{ kip})}$$

$$\text{Ratio} = 0.0017677$$

Status: **PASS**  
Ratio: **0.000****Shear Strength (ACI 318-19, LRFD)****Parameters:** $b_w = 48 \text{ in}$  - Effective width,22.5.2.2  $d$  - Effective depth

$$d = 0.80 D$$

$$d = 0.80 \times (48 \text{ in})$$

$$d = 38.4 \text{ in}$$

22.5.5.1.3  $\lambda_s$  - size effect modification factor

$$\lambda_s = \text{MIN} \left[ \sqrt{\frac{2}{1 + \frac{d}{10}}}, 1 \right]$$

$$\lambda_s = \text{MIN} \left[ \sqrt{\frac{2}{1 + \frac{(38.4 \text{ in})}{10}}}, 1 \right]$$

$$\lambda_s = 0.64282$$

The following variables were converted to be consistent with empirical formula  $f'_{ck} = 2.5 \text{ ksi} \rightarrow 2500 \text{ psi}$ ,22.5.5.1.1  $V_{c,max}$  - Max shear strength of concrete

$$V_{c,max} = 5 \lambda_s \sqrt{f'_{ck}} b_w d$$

$$V_{c,max} = 5 \times (0.64282) \times \sqrt{(2500 \text{ psi})} \times (48 \text{ in}) \times (38.4 \text{ in})$$

$$V_{c,max} = 296.21 \text{ kip}$$

The following variables were converted to be consistent with empirical formula  $f'_{ck} = 2.5 \text{ ksi} \rightarrow 2500 \text{ psi}$ ,  $P = 4.729 \text{ kip} \rightarrow 4729 \text{ lbf}$ ,22.5.5.1.1(a)  $V_{c,a}$  - Shear strength of concrete (a)

$$V_{c,a} = \left[ 2 \lambda_s \sqrt{f'_{ck}} + \frac{P}{6 A_g} \right] b_w d$$

$$V_{c,a} = \left[ 2 \times (0.64282) \times \sqrt{(2500 \text{ psi})} + \frac{(4729 \text{ lbf})}{6 \times (2304 \text{ in}^2)} \right] \times (48 \text{ in}) \times (38.4 \text{ in})$$

$$V_{c,a} = 119.12 \text{ kip}$$

The following variables were converted to be consistent with empirical formula  $f'_{ck} = 2.5 \text{ ksi} \rightarrow 2500 \text{ psi}$ ,22.5.5.1.2  $V_{c,b}$  - Shear strength of concrete (b)

$$V_{c,b} = \left[ 2 \lambda_s \sqrt{f'_{ck}} + (0.05 f'_{ck}) \right] b_w d$$

$$V_{c,b} = \left[ 2 \times (0.64282) \times \sqrt{(2500 \text{ psi})} + (0.05 \times (2500 \text{ psi})) \right] \times (48 \text{ in}) \times (38.4 \text{ in})$$

$$V_{c,b} = 348.89 \text{ kip}$$

 $V_c$  - Governing shear strength of concrete

$$V_c = \text{Min}[V_{c,max}, V_{c,a}, V_{c,b}]$$

$$V_c = \text{Min}[(296.21 \text{ kip}), (119.12 \text{ kip}), (348.89 \text{ kip})]$$

$$V_c = 119.12 \text{ kip}$$

<p>22.5.1.2</p>	<p>The following variables were converted to be consistent with empirical formula <math>f'_{ck} = 2.5 \text{ ksi} \rightarrow 2500 \text{ psi}</math>,</p> <p><math>V_{s,a}</math> - Shear strength of steel (a)</p> $V_{s,a} = 8 \sqrt{f'_{ck}} b_w d$ $V_{s,a} = 8 \times \sqrt{(2500 \text{ psi})} \times (48 \text{ in}) \times (38.4 \text{ in})$ $V_{s,a} = 737.28 \text{ kip}$ <p><math>A_v</math> - Ties rebar area,</p> $A_v = \frac{\pi d_{ties}^2}{4}$ $A_v = \frac{\pi \times (0.375 \text{ in})^2}{4}$ $A_v = 0.11045 \text{ in}^2$ <p>22.5.8.5.3 <math>V_{s,b}</math> - Shear strength of steel (b)</p> $V_{s,b} = \frac{2 A_v f_{ywk} d}{s_{ties}}$ $V_{s,b} = \frac{2 \times (0.11045 \text{ in}^2) \times (60 \text{ ksi}) \times (38.4 \text{ in})}{(10 \text{ in})}$ $V_{s,b} = 50.894 \text{ kip}$ <p><math>V_s</math> - Governing shear strength of steel</p> $V_s = \text{MIN}[V_{s,a}, V_{s,b}]$ $V_s = \text{MIN}[(737.28 \text{ kip}), (50.894 \text{ kip})]$ $V_s = 50.894 \text{ kip}$ <p>22.5.1.1 <math>\phi V_n</math> - Allowable shear strength</p> $\phi V_n = \phi (V_c + V_s)$ $\phi V_n = (0.65) \times ((119.12 \text{ kip}) + (50.894 \text{ kip}))$ $\phi V_n = 110.51 \text{ kip}$ <p><b>Considering x-direction:</b></p> <p><math>V_{max} = 10.15 \text{ kip}</math> - Maximum shear force in the x-direction,  <b>Ratio</b> - Capacity</p> $\text{Ratio} = \frac{V_{max}}{\phi V_n}$ $\text{Ratio} = \frac{(10.15 \text{ kip})}{(110.51 \text{ kip})}$ $\text{Ratio} = 0.091848$	<p>Status: <b>PASS</b>  Ratio: <b>0.090</b></p>
<p>14.5.2.1b</p>	<p><b>Flexural Strength (ACI 318-19, LRFD)</b></p> <p><math>S_m</math> - Section modulus</p> $S_m = \frac{b D^2}{6}$ $S_m = \frac{(48 \text{ in}) \times (48 \text{ in})^2}{6}$ $S_m = 18432 \text{ in}^3$ <p><math>\lambda = 1</math> - Concrete modification factor (Normal concrete),  Allowable flexural strength:  <math>M_n</math> shall be the lesser of:</p> <p><math>\phi M_{n,1}</math></p> $\phi M_{n,1} = \phi \times 5 \times \lambda \times \sqrt{f'_c} \times S_m$ $\phi M_{n,1} = 0.65 \times 5 \times 1 \times \sqrt{(2.5 \text{ ksi})} \times 18432.001 \text{ in}^3$ $\phi M_{n,1} = 249.600 \text{ kip ft}$ <p><math>\phi M_{n,2}</math></p> $\phi M_{n,2} = \phi \times 0.85 \times f'_c \times S_m$	

$\phi M_{n,2} = \phi M_{n,1}$

$$\phi M_{n,2} = (0.65) \times 0.85 \times (2.5 \text{ ksi}) \times (18432 \text{ in}^3)$$

$$\phi M_{n,2} = 2121.6 \text{ kipft}$$

Therefore,  
 $\phi M_n$  - Allowable flexural strength,

$$\phi M_n = \text{MIN}[\phi M_{n,1}, \phi M_{n,2}]$$

$$\phi M_n = \text{MIN}[(249.6 \text{ kipft}), (2121.6 \text{ kipft})]$$

$$\phi M_n = 249.6 \text{ kipft}$$

**Considering x-direction:**

$M_{max} = 32.799 \text{ kipft}$  - Maximum moment in the x-direction,  
*Ratio* - Capacity

$$\text{Ratio} = \frac{M_{max}}{\phi M_n}$$

$$\text{Ratio} = \frac{(32.799 \text{ kipft})}{(249.6 \text{ kipft})}$$

$$\text{Ratio} = 0.1314$$

Status: **PASS**  
Ratio: **0.130**