

Project Name: MTSOLAR_0A45F298K6L97-5x2

Date: Wed Feb 19 2025

Design

Number of Modules: 10

Location: Dallas, TX, USA

Number of Poles: 1

Unique ID: 1P-0-6TOP-SD-45-L-5Hx2W-41AK

Date Sold:

Dealer: _____

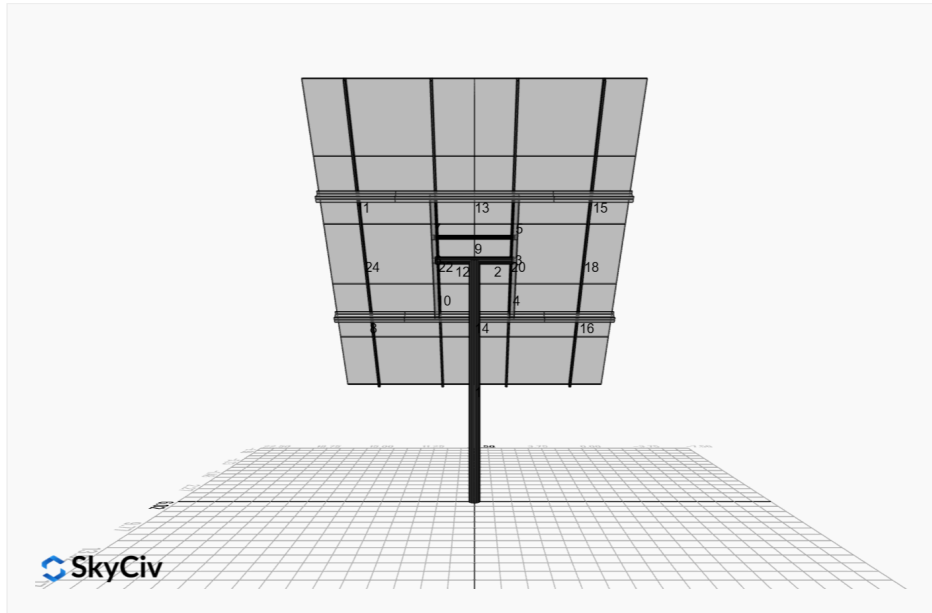

Array Dimensions N/S	18.75 ft
Array Dimensions E/W	14.93 ft
Winter Tilt Angle	50
Front Edge Clearance	5 ft

MT Solar Bill of Materials (1P-0-6TOP-SD-45-L-5Hx2W-41AK)

Part	Short Description	BOM Qty
MTS-PC-6	6IN Pole Cap Assembly	1
MTS-HF-SD	H-Frame Assembly-SD	1
MTS-SD-Wing-45	45IN SD Wing	4
MTS-CLAMP-ANGLE-4PK	Angle Clamp	2

Rail Bill of Materials

Part	Qty
Rails (222in)	4
Rail Attachment	16
Module Mid Clamp	16
Module End Clamp	8
Ground Lug	2

Site Details:

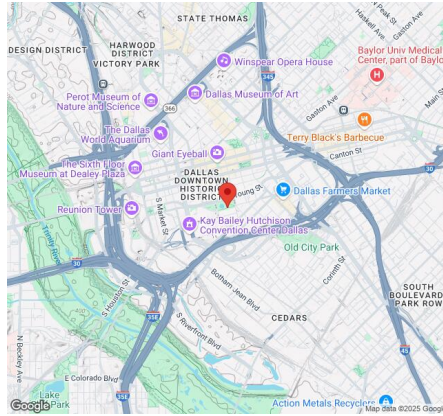

Site Address: Dallas, TX, USA

Array Specification

Duty Classification:	SD
Module Width:	44.49 in
Module Length:	88.58in
Number of Rows:	5
Number of Columns:	2
Total Number of Modules:	10
Winter Tilt Angle:	50
Front Edge Clearance:	5
Total Array Height at Tilt:	19.36 ft
Total Frame Length:	15.00 ft
Frame Weight:	981 lbs
Array Dimensions N/S:	18.75 ft
Array Dimensions E/W:	14.93 ft
Rail Length:	224.95 in
Rail Spacing:	3.73 ft

Support Specifications

Pole Size:	6in Pipe Sch 80
Pole Length above Grade:	12.18 ft
Number of Poles:	1
Pole Spacing:	0

Foundation Specifications

Foundation Type:	Square
Foundation Dimensions:	48 x 48 in
Foundation Depth (below grade):	Pile 1: 6.50 ft
Foundation Volume:	3.852 y ³

Site Info

Risk Category:	I
Exposure:	C
Soil Classification:	sand
Site Location:	Dallas, TX, USA
Wind Speed:	94 mph
Snow Load:	68.9 psf

Design Disclaimer

This software should be used for preliminary designs and should not be used as a final design unless reviewed, verified and designed by a qualified structural engineer.

AutoDesigner Input

```
{ "product_type": "Beam", "designer_name": "", "designer_email": "contact@JeremyClemons.com", "designer_phone": "", "project_id": "MTSOLAR_0A45F298K6L97-5x2 Design", "site_address": "Dallas, TX, USA", "module_width": 44.49, "module_length": 88.58, "number_rows": 5, "number_columns": 2, "pole_mount_section": "4_40", "core_pipe_width": 65, "core_pipe_section": "2_40", "adjuster_section": "2_40", "core_beam_height": 65, "core_beam_section": "HSS3x2x1/8", "main_pipe_section": "2_12GA", "pole_spacing": 15, "tilt_angle": 50, "ground_clearance": 5, "risk_category": "I", "exposure_category": "C", "frame_duty_override": "auto", "pole_override": "auto", "soil_type": "sand", "customer_foundation_override": "48_Square", "foundation_type": "Square", "foundation_size": 48, "check_rails": false, "wind_speed_override": 94, "snow_load_override": 68.9, "direct_snow_load": false, "add_angle_brace": false }
```

Design Notes:

- AISC Deflection checks are set to L/1 due to structure design intent
- Foundation Soil Parameters used in this Autodesign are all estimates, proper geotechnical reports are required to confirm soil profiles
- Wind speeds, snow loads and other site specific results are based on ASCE 7 2016
- Steel frame design checks are based on AISC 360 2016 (LRFD)
- Foundation Design and Sizing is approximate only

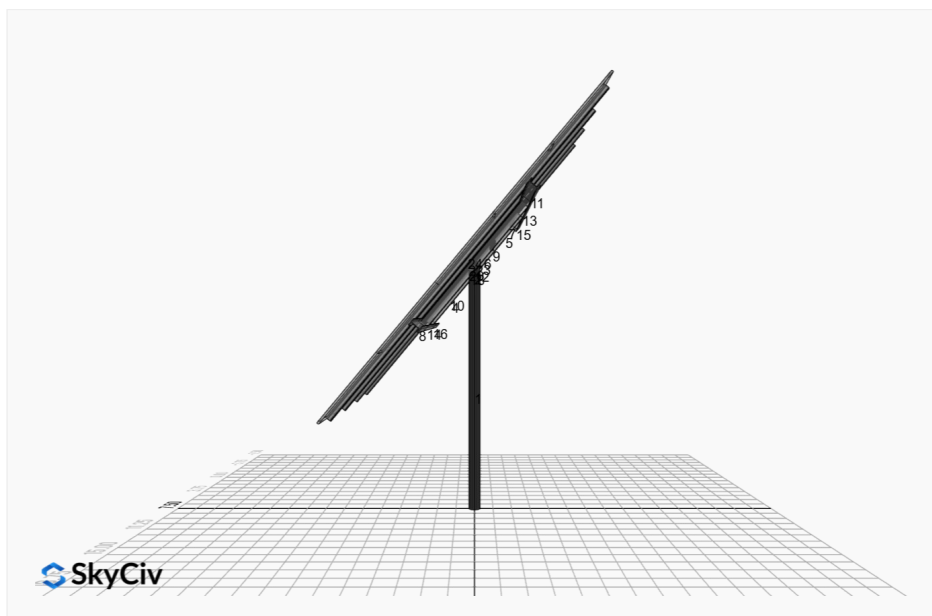
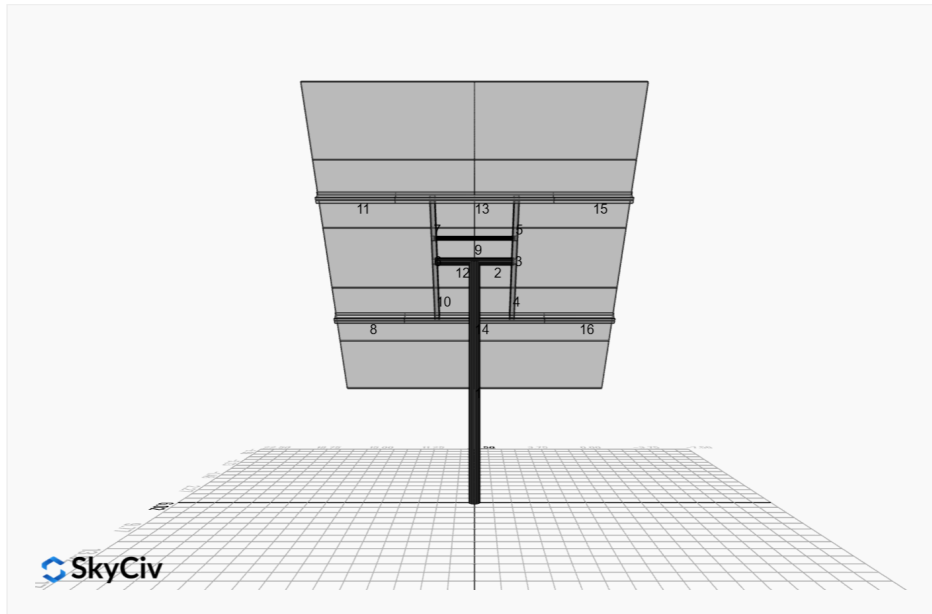

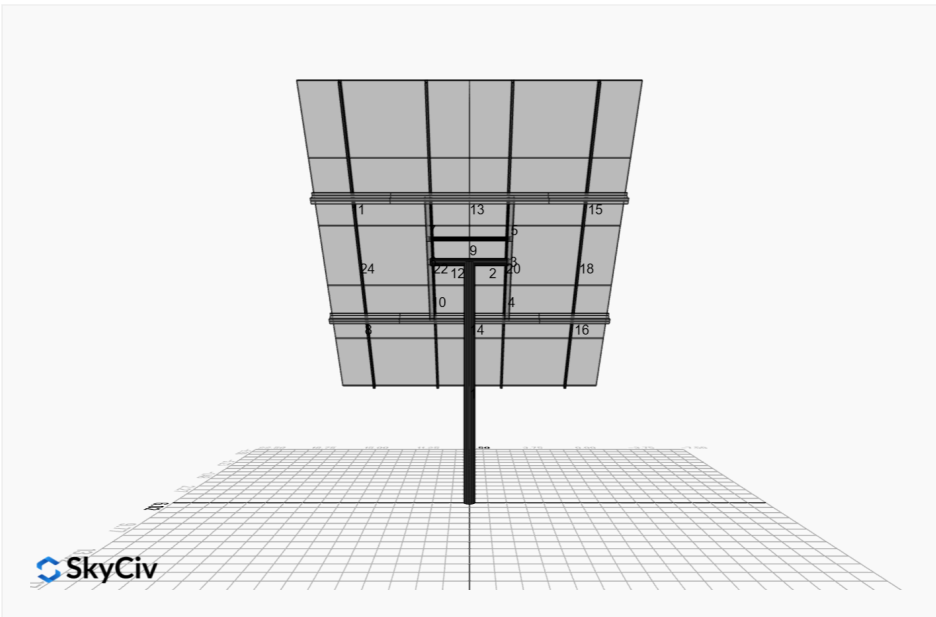
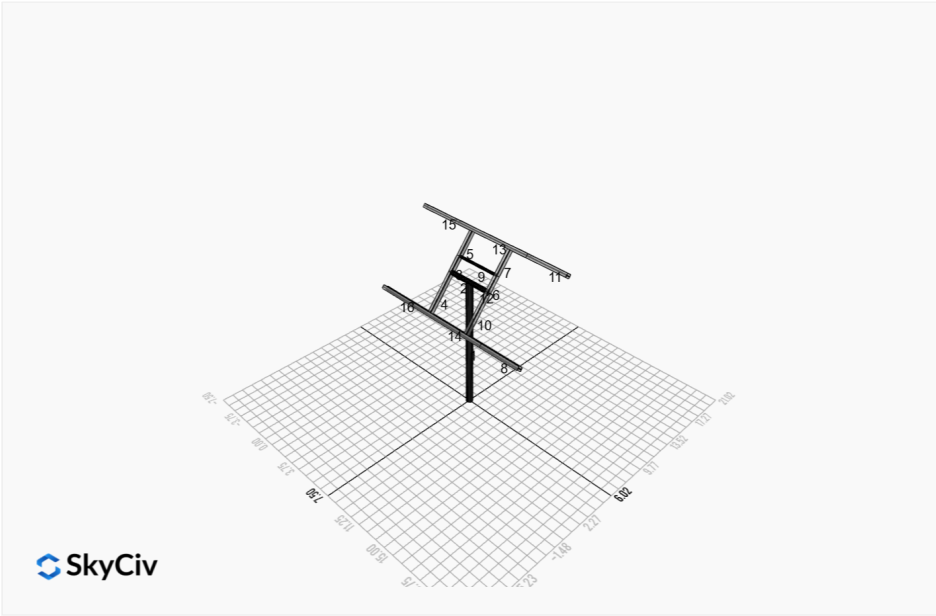
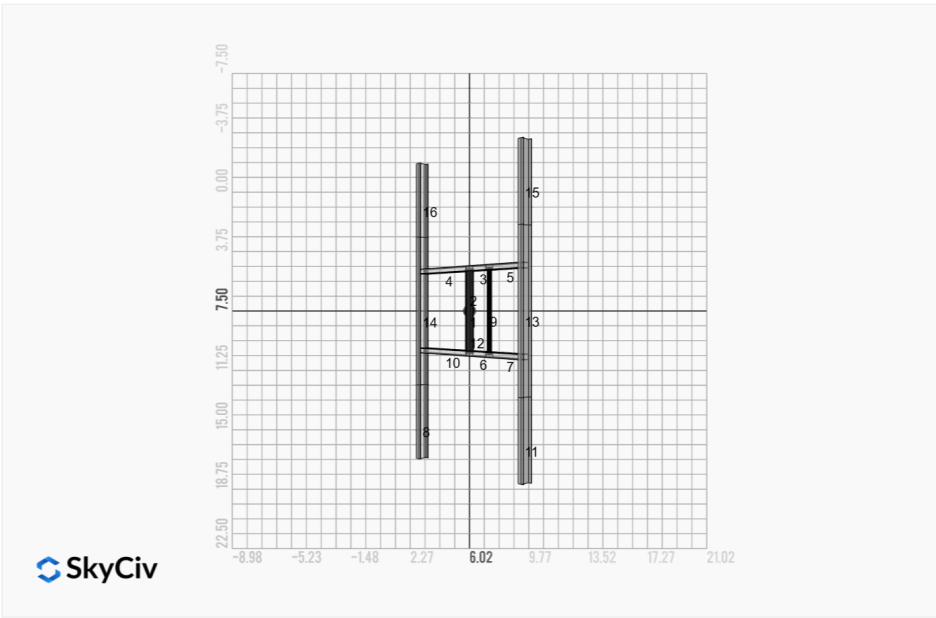

FEM Results (Envelope Worst Case for each member)

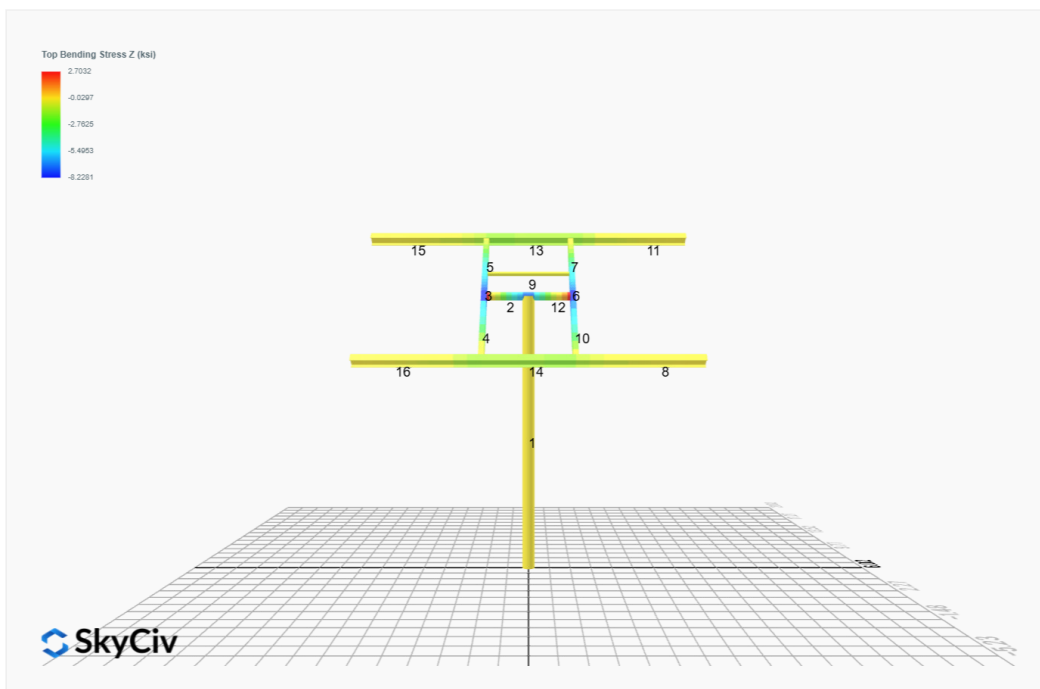
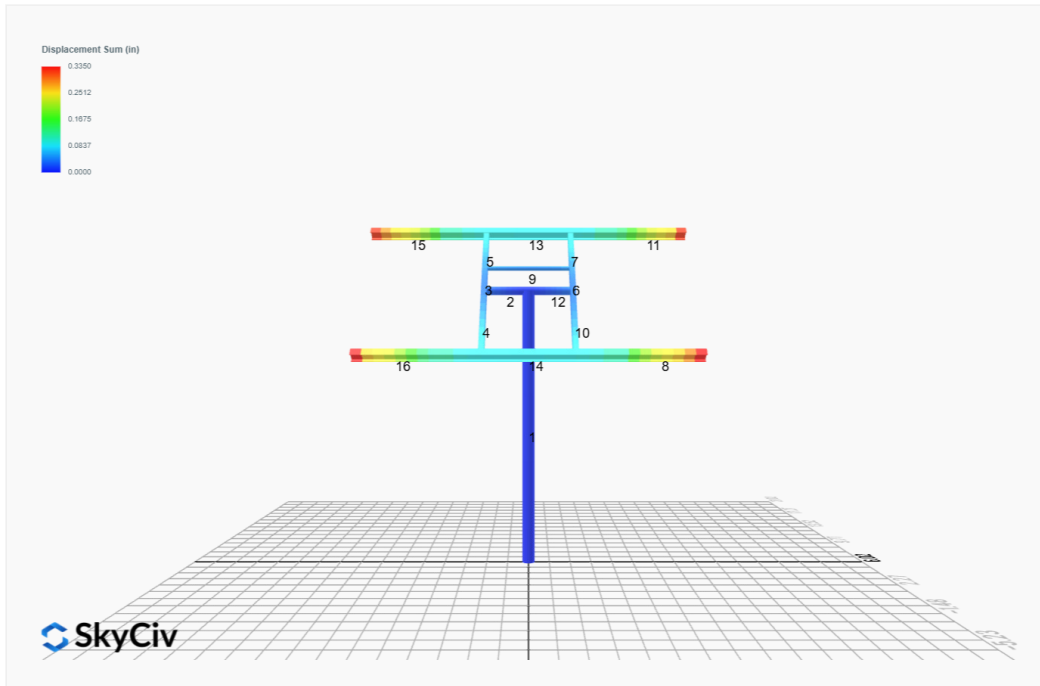

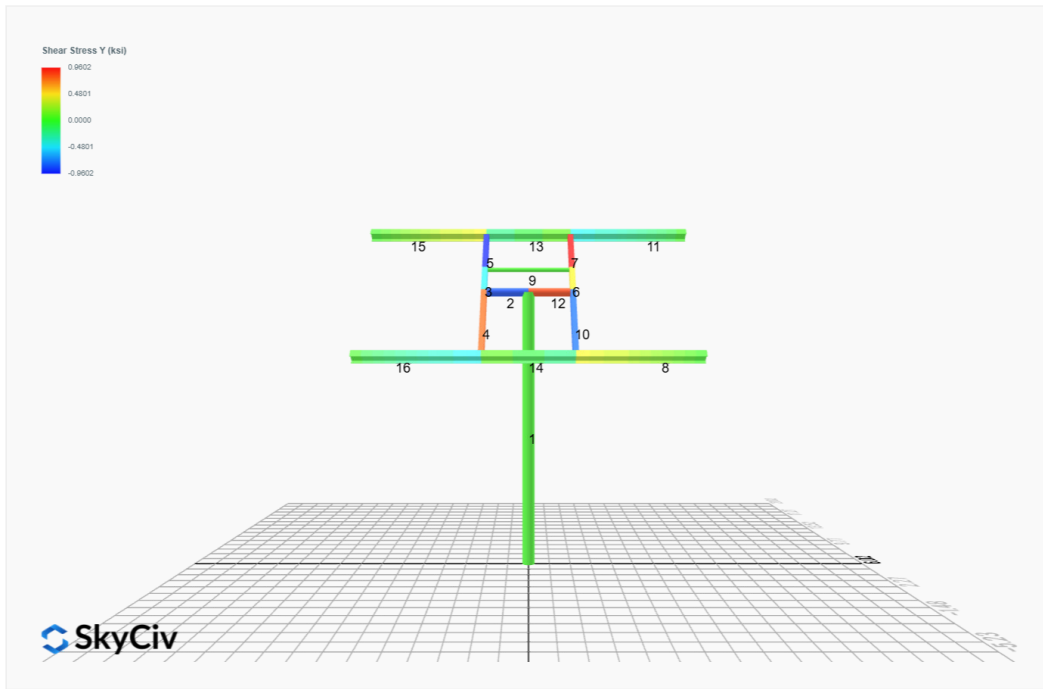
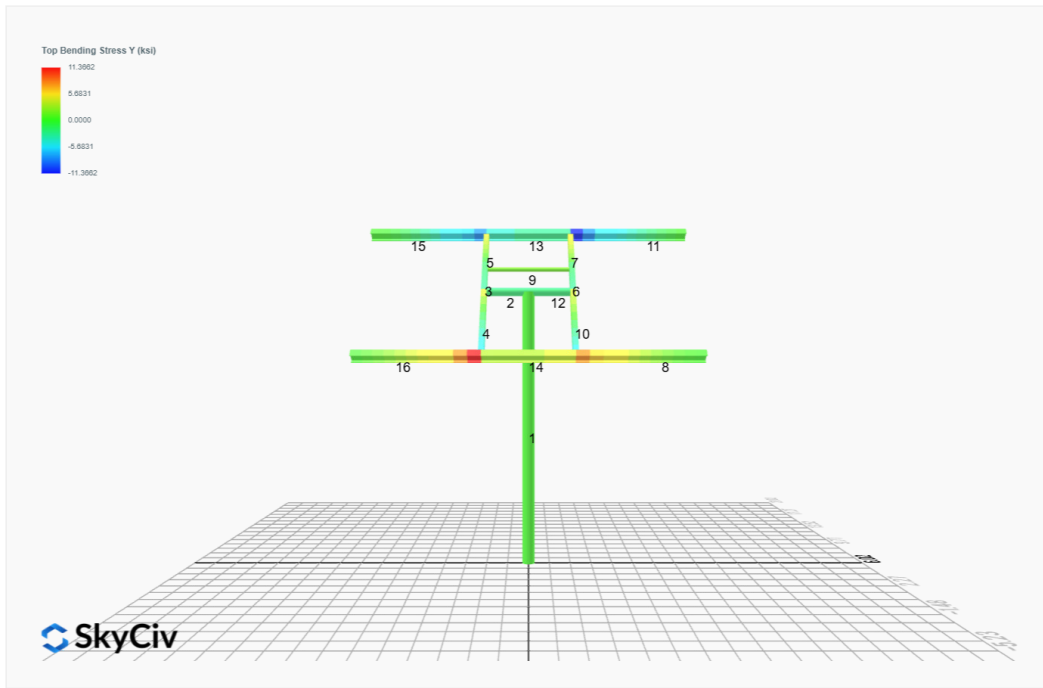

Reaction Forces for Foundation 1 (Node ID#1), (kip, kip-ft)

ASD Load Combination Results

Name	Fx	Fy	Fz	Mx	My	Mz
ULS: 1. D	0.0000	2.0096	0.0000	0.0000	-0.0000	0.0164
ULS: 2. D + L	0.0000	2.0096	0.0000	0.0000	-0.0000	0.0164
ULS: 3. D + (S or Lr or R)	0.0000	4.7484	0.0000	0.0000	-0.0000	0.0301
ULS: 3. D + (S or Lr or R)	0.0000	2.0096	0.0000	0.0000	-0.0000	0.0164
ULS: 4. D + 0.75L + 0.75(S or Lr or R)	0.0000	4.0637	0.0000	0.0000	-0.0000	0.0266
ULS: 4. D + 0.75L + 0.75(S or Lr or R)	0.0000	2.0096	0.0000	0.0000	-0.0000	0.0164
ULS: 5b. D + 0.7E	0.0000	2.0096	0.0000	0.0000	-0.0000	0.0164
ULS: 6b. D + 0.75L + 0.75(0.7)E + 0.75S	0.0000	4.0637	0.0000	0.0000	-0.0000	0.0266
ULS: 8. 0.6D + 0.7E	0.0000	1.2058	0.0000	0.0000	-0.0000	0.0098
ULS: 5a. D + 0.6W_Wind downforce Case A only	-2.3202	3.9565	0.0000	0.0000	-0.0000	28.8462
ULS: 5a. D + 0.6W_Wind downforce Case B only	0.0000	2.0096	0.0000	0.0000	-0.0000	0.0164
ULS: 5a. D + 0.6W_Wind uplift Case A only	2.3202	0.0627	0.0000	0.0000	-0.0000	-27.7006
ULS: 5a. D + 0.6W_Wind uplift Case B only	0.0000	2.0096	0.0000	0.0000	-0.0000	0.0164
ULS: 6a. D + 0.75L + 0.75(0.6)W + 0.75(S or Lr or R)_Wind downforce Case A only	-1.7402	5.5239	0.0000	0.0000	-0.0000	21.6490
ULS: 6a. D + 0.75L + 0.75(0.6)W + 0.75(S or Lr or R)_Wind downforce Case B only	0.0000	4.0637	0.0000	0.0000	-0.0000	0.0266
ULS: 6a. D + 0.75L + 0.75(0.6)W + 0.75(S or Lr or R)_Wind uplift Case A only	1.7402	2.6036	0.0000	0.0000	-0.0000	-20.7611
ULS: 6a. D + 0.75L + 0.75(0.6)W + 0.75(S or Lr or R)_Wind uplift Case B only	0.0000	4.0637	0.0000	0.0000	-0.0000	0.0266
ULS: 6a. D + 0.75L + 0.75(0.6)W + 0.75(S or Lr or R)_Wind downforce Case A only	-1.7402	3.4698	0.0000	0.0000	-0.0000	21.6387
ULS: 6a. D + 0.75L + 0.75(0.6)W + 0.75(S or Lr or R)_Wind downforce Case B only	0.0000	2.0096	0.0000	0.0000	-0.0000	0.0164
ULS: 6a. D + 0.75L + 0.75(0.6)W + 0.75(S or Lr or R)_Wind uplift Case A only	1.7402	0.5494	0.0000	0.0000	-0.0000	-20.7714
ULS: 6a. D + 0.75L + 0.75(0.6)W + 0.75(S or Lr or R)_Wind uplift Case B only	0.0000	2.0096	0.0000	0.0000	-0.0000	0.0164
ULS: 7. 0.6D + 0.6W_Wind downforce Case A only	-2.3202	3.1526	0.0000	0.0000	-0.0000	28.8396
ULS: 7. 0.6D + 0.6W_Wind downforce Case B only	0.0000	1.2058	0.0000	0.0000	-0.0000	0.0098
ULS: 7. 0.6D + 0.6W_Wind uplift Case A only	2.3202	-0.7411	0.0000	0.0000	-0.0000	-27.7072
ULS: 7. 0.6D + 0.6W_Wind uplift Case B only	0.0000	1.2058	0.0000	0.0000	-0.0000	0.0098

Worst Case Reactions LRFD

These calculations are taken directly from the FEA via SkyCiv and are used in the Concrete Checks of the Foundation Module.

Note: Worst case values are assumed as downforce wind load cases.

Result	Value (kip, kip-ft)
Axial	8.4160
Shear X	-3.8670
Shear Z	0.0000
Moment X	0.0000
Moment Y (Twist)	0.0000
Moment Z	49.3024

Worst Case Reactions ASD

These results are taken from the worst case values in the above table and are used in the Soil Checks in the Foundation Module.

Note: Worst case values are assumed as downforce wind load cases.

Result	Value (kip, kip-ft)
Axial	5.5239
Shear X	-2.3202
Shear Z	0.0000
Moment X	0.0000
Moment Y (Twist)	0.0000
Moment Z	28.8462

Project Details

Design Code: AISC 360-16 LRFD
 Provision: LRFD
 Country: United States

 User Name: sales@mtsolar.us
 Project Name: MTSOLAR_0A45F298K6L97-5x2 Design
 Unit System: imperial



Design Input Information

Design Factors			
Φ_t	Φ_c	Φ_b	Φ_v
0.9	0.9	0.9	0.9

Design Materials			
ID	E (ksi)	F_y (ksi)	F_u (ksi)
1	29000	50	65

Section Dimensions

ID	Name	d (in)	t_w (in)				
1	2in Pipe Sch 40	2.38	0.15				
4	4in Pipe Sch 40	4.50	0.24				
8	6in Pipe Sch 80	6.63	0.43				

ID	Name	d (in)	b (in)	t_w (in)	t_b (in)	r (in)	
15	HSS5x3x1/8	5.00	3.00	0.12	0.12	0.12	

ID	Name	d (in)	t_w (in)	b_t (in)	b_b (in)	t_t (in)	t_b (in)	r (in)
18	W6x9	5.90	0.17	3.94	3.94	0.21	0.21	0.25

Section Properties								
ID	Name	A (in ²)	J (in ⁴)	I_{y0} (in ⁴)	I_{z0} (in ⁴)	I_w (in ⁶)	S_{y0} (in ³)	S_{z0} (in ³)

14	120.60	84.03	18.34	6.45	30.09	45.74
15	120.60	54.44	23.36	6.45	30.09	45.74
16	120.60	54.44	23.36	6.45	30.09	45.74

Design Ratio

Member ID	P	M _z	M _y	V _y	V _z	(P,M _z ,M _y)	Worst LC	KL/r	δ	Status
1	0.087	0.792	0.000	0.034	0.000	0.828	#13	0.699	Not Required	Pass
2	0.003	0.381	0.249	0.093	0.045	0.585	#13	0.034	Not Required	Pass
3	0.016	0.619	0.118	0.062	0.017	0.696	#21	0.044	Not Required	Pass
4	0.015	0.615	0.263	0.061	0.045	0.755	#21	0.078	Not Required	Pass
5	0.016	0.384	0.272	0.061	0.054	0.422	#21	0.073	Not Required	Pass
6	0.016	0.619	0.118	0.062	0.017	0.696	#21	0.044	Not Required	Pass
7	0.016	0.384	0.272	0.061	0.054	0.422	#21	0.073	Not Required	Pass
8	0.000	0.071	0.173	0.029	0.013	0.238	#21	Not Required	Not Required	Pass
9	0.014	0.040	0.059	0.001	0.000	0.102	#13	0.198	Not Required	Pass
10	0.015	0.615	0.263	0.061	0.045	0.754	#21	0.078	Not Required	Pass
11	0.000	0.071	0.173	0.029	0.013	0.238	#21	Not Required	Not Required	Pass
12	0.003	0.381	0.249	0.093	0.045	0.585	#13	0.034	Not Required	Pass
13	0.007	0.205	0.371	0.043	0.019	0.550	#21	0.177	Not Required	Pass
14	0.009	0.209	0.371	0.043	0.019	0.550	#21	0.177	Not Required	Pass
15	0.000	0.071	0.173	0.029	0.013	0.238	#21	Not Required	Not Required	Pass
16	0.000	0.071	0.173	0.029	0.013	0.238	#21	Not Required	Not Required	Pass

Definitions

Φ _t	Safety factor for tensile
Φ _c	Safety factor for compression
Φ _b	Safety factor for flexure
Φ _v	Safety factor for shear
E	Modulus of elasticity
F _y	Specified minimum yield stress
F _u	Specified minimum tensile strength
A	Cross-sectional area
J	Torsional constant
I _{yp}	Moment of inertia about the Y axes
I _{zp}	Moment of inertia about the Z axes
I _w	Warping constant
S _{yp}	Plastic section modulus about the Y axis
S _{zp}	Plastic section modulus about the Z axis
KL	Effective length
C _b	Buckling modification factor (from all load combinations)
L _b	Length between braced points
LST	Limited slenderness for tension
LSC	Limited slenderness for compression
LD	Limited deflection
P _n	Nominal axial strength (tension/compression)
M _n	Nominal flexural strength (about Z/Y axis)
V _n	Nominal shear strength (along Z/Y axis)
P	Design ratio in case of axial force
M _z	Design ratio in case of bending about Z axis
M _y	Design ratio in case of bending about Y axis
V _y	Design ratio in case of shear along Y axis
V _z	Design ratio in case of shear along Z axis
(P,M _z ,M _y)	Design ratio in case of axial force and bending action
KL/r	Design ratio in case of section slenderness
δ	Design ratio in case of member deflection
OK	Capacity is provided
NG	Capacity is not provided

REFERENCES	CALCULATIONS	RESULTS
------------	--------------	---------

SkyCiv Foundation Design

Pile Foundation

Design Information :

Design code : IBC 2021 (International Building Code)
Unit System : Imperial

Pile Input

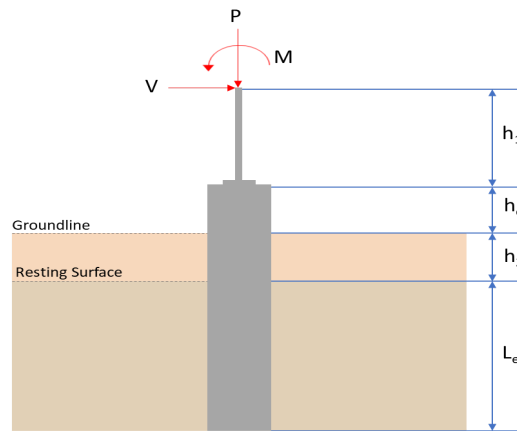

Geometry

Pile shape: rectangular

$b = 48$ in - Pile width

$D = 48$ in - Pile depth

$L = 6.5$ ft - Total pile length

$h_1 = 0$ ft - Lateral load height from the top of the pile,

$h_2 = 0$ ft - Depth to resisting surface

$h_e = 0$ ft - Length of pile above the ground

Tabulation of Soil Parameters

Layer	Label	Allowable Bearing Pressure (q_a) (psf)	Allowable Lateral Pressure (R) (psf/ft)
1	Sand, silty sand, clayey sand, silty gravel & clayey gravel	2000.000	150.000

Tabulation of Loads

Load Component	ASD	LRFD
P (kip)	5.524	8.416
V_x (kip)	-2.320	-3.867
V_z (kip)	0.000	0.000
M_x (kipft)	0.000	0.000
M_z (kipft)	28.846	49.302

Material Properties

$f'_{ck} = 2.5$ ksi - Concrete strength.

Required depth to resist lateral loads (ASD)

H - Point of application of the lateral load

$$H = h_1 + h_2 + h_e$$

$$H = (0 \text{ ft}) + (0 \text{ ft}) + (0 \text{ ft})$$

$$H = 0 \text{ ft}$$

Considering x-direction:

H_o - Lateral force per length of pile,

$$H_o = \frac{V_x}{1.57 D}$$

$$H_o = \frac{(-2.32 \text{ kip})}{1.57 \times (48 \text{ in})}$$

$$H_o = -0.36943 \text{ kip/ft}$$

M_o - Moment per length of pile,

$$M_o = \frac{M_z + (V_x H)}{1.57 D}$$

$$M_o = \frac{(28.846 \text{ kipft}) + ((-2.32 \text{ kip}) \times (0 \text{ ft}))}{1.57 \times (48 \text{ in})}$$

$$M_o = 4.5933 \text{ kipft/ft}$$

Required depth of embedment in earth:

$$L_x^3 - \left(14.14 \times \frac{H_o \times L_x}{R}\right) - \left(18.85 \times \frac{M_o}{R}\right) = 0$$

Solving the cubic equation:

$L_{e,x} = 6.1392 \text{ ft}$ - Required depth in x-direction,

Considering z-direction:

$L_{e,z} = 0 \text{ ft}$ - Required depth in z-direction,

Minimum embedded depth required:

$L_{e,req}$ - Depth of pile required,

$$L_{e,req} = \text{MAX}[L_{e,x}, L_{e,z}]$$

$$L_{e,req} = \text{MAX}[(6.1392 \text{ ft}), (0 \text{ ft})]$$

$$L_{e,req} = 6.139 \text{ ft}$$

L_e - Actual embedded length of pile,

$$L_e = L - h_e - h_2$$

$$L_e = (6.5 \text{ ft}) - (0 \text{ ft}) - (0 \text{ ft})$$

$$L_e = 6.5 \text{ ft}$$

Ratio - Embedded depth

$$\text{Ratio} = \frac{L_{e,req}}{L_e}$$

$$\text{Ratio} = \frac{(6.139 \text{ ft})}{(6.5 \text{ ft})}$$

$$\text{Ratio} = 0.94446$$

Status: **PASS**
Ratio: **0.940**

End-bearing Capacity (ASD)

A - Pile cross-section area

$$A = b D$$

$$A = (48 \text{ in}) \times (48 \text{ in})$$

$$A = 16 \text{ ft}^2$$

q - End-bearing pressure

$$q = \frac{P_v}{A}$$

$$q = \frac{(5.524 \text{ kip})}{(16 \text{ ft}^2)}$$

$$q = 0.34525 \text{ kip/ft}^2$$

Check bearing capacity ratio:

Ratio - Capacity

$$\text{Ratio} = \frac{q}{q_a}$$

$$\text{Ratio} = \frac{(0.34525 \text{ kip/ft}^2)}{(2000 \text{ psf})}$$

$$\text{Ratio} = 0.17263$$

Status: **PASS**
Ratio: **0.170**

Czerniak

Lateral Soil Pressure (ASD):

L/D - Length to least lateral dimension ratio,

$$L/D = \frac{L}{D}$$

$$L/D = \frac{(6.5 \text{ ft})}{(48 \text{ in})}$$

$$L/D = 1.625$$

Since $L/D \leq 10$,

Pile is short.

Considering x-direction:

$H_o = -0.36943 \text{ kip/ft}$ - Lateral force per length of pile,

$M_o = 4.5933 \text{ kipft/ft}$ - Overturning moment per length of pile,

a - Distance from resting surface to pivot point,

$$a = \frac{(4 M_o L_e) + (3 H_o L_e^2)}{(6 M_o) + (4 H_o L_e)}$$

$$a = \frac{(4 \times (4.5933 \text{ kipft/ft}) \times (6.5 \text{ ft})) + (3 \times (-0.36943 \text{ kip/ft}) \times (6.5 \text{ ft})^2)}{(6 \times (4.5933 \text{ kipft/ft})) + (4 \times (-0.36943 \text{ kip/ft}) \times (6.5 \text{ ft}))}$$

$$a = 4.4733 \text{ ft}$$

p - Earth pressure against the pile at distance $a/2$ from resting surface,

$$p = \frac{0.75 [(4 M_o) + (3 H_o L_e)]^2}{L_e^2 [(3 M_o) + (2 H_o L_e)]}$$

$$p = \frac{0.75 \times [(4 \times (4.5933 \text{ kipft/ft})) + (3 \times (-0.36943 \text{ kip/ft}) \times (6.5 \text{ ft}))]^2}{(6.5 \text{ ft})^2 \times [(3 \times (4.5933 \text{ kipft/ft})) + (2 \times (-0.36943 \text{ kip/ft}) \times (6.5 \text{ ft}))]}$$

$$p = 0.24669 \text{ kip/ft}^2$$

s - Earth pressure against the pile at distance L_e ,

$$s = \frac{6 [(2 M_o) + (H_o L_e)]}{L_e^2}$$

$$s = \frac{6 \times [(2 \times (4.5933 \text{ kipft/ft})) + ((-0.36943 \text{ kip/ft}) \times (6.5 \text{ ft}))]}{(6.5 \text{ ft})^2}$$

$$s = 0.9636 \text{ kip/ft}^2$$

Check lateral soil pressure capacity:

p_a - Allowable lateral soil pressure at depth $a/2$,

$$p_a = R \frac{a}{2}$$

$$p_a = (150 \text{ psf/ft}) \times \frac{(4.4733 \text{ ft})}{2}$$

$$p_a = 0.3355 \text{ kip/ft}^2$$

Ratio - Lateral soil capacity

$$\text{Ratio} = \frac{p}{p_a}$$

$$\text{Ratio} = \frac{(0.24669 \text{ kip/ft}^2)}{(0.3355 \text{ kip/ft}^2)}$$

$$\text{Ratio} = 0.73528$$

p_s - Allowable lateral soil pressure at depth L_e ,

$$p_s = R L_e$$

$$p_s = (150 \text{ psf/ft}) \times (6.5 \text{ ft})$$

$$p_s = 0.975 \text{ kip/ft}^2$$

Ratio - Lateral soil capacity

$$\text{Ratio} = \frac{s}{p_s}$$

$$\text{Ratio} = \frac{(0.9636 \text{ kip/ft}^2)}{(0.975 \text{ kip/ft}^2)}$$

Status: **PASS**
Ratio: **0.740**

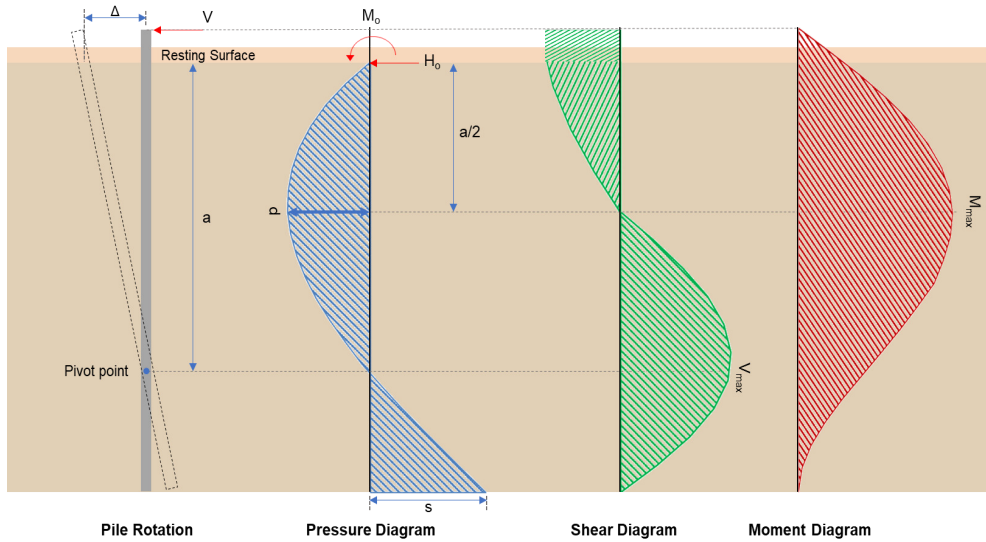

Shear force and Bending moment (x-direction, LRFD)

H_o - Lateral force per length of pile,

$$H_o = \frac{V_x}{1.57 D}$$

$$H_o = \frac{(-3.867 \text{ kip})}{1.57 \times (48 \text{ in})}$$

$$H_o = -0.61576 \text{ kip/ft}$$

M_o - Moment per length of pile,

$$M_o = \frac{M_z + (V_x H)}{1.57 D}$$

$$M_o = \frac{(49.302 \text{ kipft}) + ((-3.867 \text{ kip}) \times (0 \text{ ft}))}{1.57 \times (48 \text{ in})}$$

$$M_o = 7.8506 \text{ kipft/ft}$$

E - Distance from lateral load to resisting surface,

$$E = \frac{M_o}{H_o}$$

$$E = \frac{(7.8506 \text{ kipft/ft})}{(-0.61576 \text{ kip/ft})}$$

$$E = 12.749 \text{ ft}$$

a - Distance from resting surface to pivot point,

$$a = \frac{(4 M_o L_e) + (3 H_o L_e^2)}{(6 M_o) + (4 H_o L_e)}$$

$$a = \frac{(4 \times (7.8506 \text{ kipft/ft}) \times (6.5 \text{ ft})) + (3 \times (-0.61576 \text{ kip/ft}) \times (6.5 \text{ ft})^2)}{(6 \times (7.8506 \text{ kipft/ft})) + (4 \times (-0.61576 \text{ kip/ft}) \times (6.5 \text{ ft}))}$$

$$a = 4.4707 \text{ ft}$$

V_{max} - Max shear force located at depth a ,

$$V_{max} = (H_o D) \left[1 - \left[3 \left(\frac{4 E}{L_e} + 3 \right) \left(\frac{a}{L_e} \right)^2 \right] + \left[4 \left(\frac{3 E}{L_e} + 2 \right) \left(\frac{a}{L_e} \right)^3 \right] \right]$$

$$V_{max} = ((-0.61576 \text{ kip/ft}) \times (48 \text{ in})) \times \left[1 - \left[3 \times \left(\frac{4 \times (12.749 \text{ ft})}{(6.5 \text{ ft})} + 3 \right) \times \left(\frac{(4.4707 \text{ ft})}{(6.5 \text{ ft})} \right)^2 \right] + \left[4 \times \left(\frac{3 \times (12.749 \text{ ft})}{(6.5 \text{ ft})} + 2 \right) \times \left(\frac{(4.4707 \text{ ft})}{(6.5 \text{ ft})} \right)^3 \right] \right]$$

$$v_{max} = 10.175 \text{ kip}$$

M_{max} - Max bending moment located at depth $a/2$,

$$M_{max} = (H_o D L_e) \left[\left(\frac{E}{L_e} + \frac{a}{2 L_e} \right) - \left[\left(\frac{4 E}{L_e} + 3 \right) \left(\frac{a}{2 L_e} \right)^3 + \left[\left(\frac{3 E}{L_e} + 2 \right) \left(\frac{a}{2 L_e} \right)^4 \right] \right]$$

$$M_{max} = ((-0.61576 \text{ kip/ft}) \times (48 \text{ in}) \times (6.5 \text{ ft})) \times \left[\left(\frac{(12.749 \text{ ft})}{(6.5 \text{ ft})} + \frac{(4.4707 \text{ ft})}{2 \times (6.5 \text{ ft})} \right) - \left[\left(\frac{4 \times (12.749 \text{ ft})}{(6.5 \text{ ft})} + 3 \right) \times \left(\frac{(4.4707 \text{ ft})}{2 \times (6.5 \text{ ft})} \right)^3 + \left[\left(\frac{3 \times (12.749 \text{ ft})}{(6.5 \text{ ft})} + 2 \right) \times \left(\frac{(4.4707 \text{ ft})}{2 \times (6.5 \text{ ft})} \right)^4 \right] \right]$$

$$M_{max} = 31.612 \text{ kipft}$$

Minimum Reinforcement Check (LRFD)

Parameters:

$f'_{ck} = 2.5 \text{ ksi}$ - Concrete strength,
 $f_{yk} = 60 \text{ ksi}$ - Longitudinal reinforcement strength,
 $\phi = 0.65$ - Reduction factor for axial strength,
 $\alpha = 0.8$ - Alpha factor for axial strength,
 $A_g = 2304 \text{ in}^2$ - Gross area of concrete,

Table 22.4.2.1

Longitudinal reinforcement:

Required reinforcement due to axial load, $A_{st,required}$

22.4.2.2, 10.6.1.1

$A_{st,required}$

$$A_{st,required} = \text{Min} \left[\frac{\frac{P}{\phi \alpha} - (0.85 f'_{ck} A_g)}{f_{yk} - (0.85 f'_{ck})}, (0.08 A_g) \right]$$

$$A_{st,required} = \text{Min} \left[\frac{\frac{(8.416 \text{ kip})}{(0.65) \times (0.8)} - (0.85 \times (2.5 \text{ ksi}) \times (2304 \text{ in}^2))}{(60 \text{ ksi}) - (0.85 \times (2.5 \text{ ksi}))}, (0.08 \times (2304 \text{ in}^2)) \right]$$

$$A_{st,required} = -84.316 \text{ in}^2$$

A_{min} - Governing minimum reinforcement area,

$$A_{min} = \text{Max} [A_{st,required}, (0.0018 A_g)]$$

$$A_{min} = \text{Max} [(-84.316 \text{ in}^2), (0.0018 \times (2304 \text{ in}^2))]$$

$$A_{min} = 4.1472 \text{ in}^2$$

n_{rebar} - Required number of reinforcement,

$$n_{rebar} = \frac{A_{min}}{A_{rebar}}$$

$$n_{rebar} = \frac{(4.1472 \text{ in}^2)}{(0.3068 \text{ in}^2)}$$

$$n_{rebar} = 14$$

A_{st} - Actual total reinforcement area,

$$A_{st} = n_{rebar} \frac{\pi d_{bar}^2}{4}$$

$$A_{st} = (14) \times \frac{\pi \times (0.625 \text{ in})^2}{4}$$

$$A_{st} = 4.2951 \text{ in}^2$$

Ratio - Capacity

$$\text{Ratio} = \frac{A_{min}}{A_{st}}$$

$$\text{Ratio} = \frac{(4.1472 \text{ in}^2)}{(4.2951 \text{ in}^2)}$$

$$\text{Ratio} = 0.96556$$

25.2.3

s_{rebar} - Minimum spacing of reinforcement,

$$s_{rebar} = \text{Max} [1.5, (1.5 d_{bar})]$$

Status: **PASS**
Ratio: **0.970**

$$s_{rebar} = Max[1.5, (1.5 \times (0.625 \text{ in}))]$$

$$s_{rebar} = 1.5 \text{ in}$$

Ties:

25.7.2.2 Since longitudinal reinforcement is \leq No. 10 \emptyset : Use #3(0.375 in)

25.7.2.1 s_{ties} - Maximum spacing of ties,

$$s_{ties} = Min[(16 d_{bar}), (48 d_{ties}), Min(D, b)]$$

$$s_{ties} = Min[(16 \times (0.625 \text{ in})), (48 \times (0.375 \text{ in})), Min((48 \text{ in}), (48 \text{ in}))]$$

$$s_{ties} = 10 \text{ in}$$

Summary:

Main reinforcement: **14 - #5 (0.625 in)**

Ties: **#3(0.375 in) - 10 in**

Axial Compression Strength (ACI 318-19, LRFD)

22.4.2.2 ϕP_N - Allowable axial compressive strength

$$\phi P_N = \phi 0.80 [(0.85 f'_{ck} [A_g - A_{st}]) + (f_{yk} A_{st})]$$

$$\phi P_N = (0.65) \times 0.80 \times [(0.85 \times (2.5 \text{ ksi}) \times [(2304 \text{ in}^2) - (4.2951 \text{ in}^2)]) + ((60 \text{ ksi}) \times (4.2951 \text{ in}^2))]$$

$$\phi P_N = 2675.2 \text{ kip}$$

Ratio - Capacity

$$Ratio = \frac{P}{\phi P_N}$$

$$Ratio = \frac{(8.416 \text{ kip})}{(2675.2 \text{ kip})}$$

$$Ratio = 0.003146$$

Status: **PASS**
Ratio: **0.000**

Shear Strength (ACI 318-19, LRFD)

Parameters:

22.5.2.2 b_w = 48 in - Effective width,
 d - Effective depth

$$d = 0.80 D$$

$$d = 0.80 \times (48 \text{ in})$$

$$d = 38.4 \text{ in}$$

22.5.5.1.3 λ_s - size effect modification factor

$$\lambda_s = MIN \left[\sqrt{\frac{2}{1 + \frac{d}{10}}}, 1 \right]$$

$$\lambda_s = MIN \left[\sqrt{\frac{2}{1 + \frac{(38.4 \text{ in})}{10}}}, 1 \right]$$

$$\lambda_s = 0.64282$$

The following variables were converted to be consistent with empirical formula $f'_{ck} = 2.5 \text{ ksi} \rightarrow 2500 \text{ psi}$,

22.5.5.1.1 $V_{c,max}$ - Max shear strength of concrete

$$V_{c,max} = 5 \lambda_s \sqrt{f'_{ck}} b_w d$$

$$V_{c,max} = 5 \times (0.64282) \times \sqrt{(2500 \text{ psi})} \times (48 \text{ in}) \times (38.4 \text{ in})$$

$$V_{c,max} = 296.21 \text{ kip}$$

The following variables were converted to be consistent with empirical formula $f'_{ck} = 2.5 \text{ ksi} \rightarrow 2500 \text{ psi}$, $P = 8.416 \text{ kip} \rightarrow 8416 \text{ lbf}$,

22.5.5.1.1(a) $V_{c,a}$ - Shear strength of concrete (a)

$$V_{c,a} = \left[2 \lambda_s \sqrt{f'_{ck}} + \frac{P}{6 A_g} \right] b_w d$$

$$V_{c,a} = \left[2 \times (0.64282) \times \sqrt{(2500 \text{ psi})} + \frac{(8416 \text{ lbf})}{6 \times (2304 \text{ in}^2)} \right] \times (48 \text{ in}) \times (38.4 \text{ in})$$

$$V_{c,a} = 119.61 \text{ kip}$$

22.5.5.1.2 The following variables were converted to be consistent with empirical formula $f'_{ck} = 2.5 \text{ ksi} \rightarrow 2500 \text{ psi}$,
 $V_{c,b}$ - Shear strength of concrete (b)

$$V_{c,b} = \left[2 \lambda_s \sqrt{f'_{ck}} + (0.05 f'_{ck}) \right] b_w d$$

$$V_{c,b} = \left[2 \times (0.64282) \times \sqrt{(2500 \text{ psi})} + (0.05 \times (2500 \text{ psi})) \right] \times (48 \text{ in}) \times (38.4 \text{ in})$$

$$V_{c,b} = 348.89 \text{ kip}$$

V_c - Governing shear strength of concrete

$$V_c = \text{Min}[V_{c,max}, V_{c,a}, V_{c,b}]$$

$$V_c = \text{Min}[(296.21 \text{ kip}), (119.61 \text{ kip}), (348.89 \text{ kip})]$$

$$V_c = 119.61 \text{ kip}$$

22.5.1.2 The following variables were converted to be consistent with empirical formula $f'_{ck} = 2.5 \text{ ksi} \rightarrow 2500 \text{ psi}$,
 $V_{s,a}$ - Shear strength of steel (a)

$$V_{s,a} = 8 \sqrt{f'_{ck}} b_w d$$

$$V_{s,a} = 8 \times \sqrt{(2500 \text{ psi})} \times (48 \text{ in}) \times (38.4 \text{ in})$$

$$V_{s,a} = 737.28 \text{ kip}$$

A_v - Ties rebar area,

$$A_v = \frac{\pi d_{ties}^2}{4}$$

$$A_v = \frac{\pi \times (0.375 \text{ in})^2}{4}$$

$$A_v = 0.11045 \text{ in}^2$$

22.5.8.5.3 $V_{s,b}$ - Shear strength of steel (b)

$$V_{s,b} = \frac{2 A_v f_{yw} d}{s_{ties}}$$

$$V_{s,b} = \frac{2 \times (0.11045 \text{ in}^2) \times (60 \text{ ksi}) \times (38.4 \text{ in})}{(10 \text{ in})}$$

$$V_{s,b} = 50.894 \text{ kip}$$

V_s - Governing shear strength of steel

$$V_s = \text{MIN}[V_{s,a}, V_{s,b}]$$

$$V_s = \text{MIN}[(737.28 \text{ kip}), (50.894 \text{ kip})]$$

$$V_s = 50.894 \text{ kip}$$

22.5.1.1 ϕV_n - Allowable shear strength

$$\phi V_n = \phi (V_c + V_s)$$

$$\phi V_n = (0.65) \times ((119.61 \text{ kip}) + (50.894 \text{ kip}))$$

$$\phi V_n = 110.83 \text{ kip}$$

Considering x-direction:

$V_{max} = 10.175 \text{ kip}$ - Maximum shear force in the x-direction,

Ratio - Capacity

$$\text{Ratio} = \frac{V_{max}}{\phi V_n}$$

$$\text{Ratio} = \frac{(10.175 \text{ kip})}{(110.83 \text{ kip})}$$

$$\text{Ratio} = 0.091807$$

Status: **PASS**
Ratio: **0.090**

Flexural Strength (ACI 318-19, LFRD) S_m - Section modulus

$$S_m = \frac{b D^2}{6}$$

$$S_m = \frac{(48 \text{ in}) \times (48 \text{ in})^2}{6}$$

$$S_m = 18432 \text{ in}^3$$

 $\lambda = 1$ - Concrete modification factor (Normal concrete),

Allowable flexural strength:

 M_n shall be the lesser of: $\phi M_{n,1}$

$$\phi M_{n,1} = \phi \times 5 \times \lambda \times \sqrt{f'_c} \times S_m$$

$$\phi M_{n,1} = 0.65 \times 5 \times 1 \times \sqrt{2.5 \text{ ksi}} \times 18432.001 \text{ in}^3$$

$$\phi M_{n,1} = 249.600 \text{ kipft}$$

14.5.2.1b

 $\phi M_{n,2}$

$$\phi M_{n,2} = \phi \times 0.85 \times f'_c \times S_m$$

$$\phi M_{n,2} = (0.65) \times 0.85 \times (2.5 \text{ ksi}) \times (18432 \text{ in}^3)$$

$$\phi M_{n,2} = 2121.6 \text{ kipft}$$

Therefore,

 ϕM_n - Allowable flexural strength,

$$\phi M_n = \text{MIN}[\phi M_{n,1}, \phi M_{n,2}]$$

$$\phi M_n = \text{MIN}[(249.6 \text{ kipft}), (2121.6 \text{ kipft})]$$

$$\phi M_n = 249.6 \text{ kipft}$$

Considering x-direction: $M_{max} = 31.612 \text{ kipft}$ - Maximum moment in the x-direction,

Ratio - Capacity

$$\text{Ratio} = \frac{M_{max}}{\phi M_n}$$

$$\text{Ratio} = \frac{(31.612 \text{ kipft})}{(249.6 \text{ kipft})}$$

$$\text{Ratio} = 0.12665$$

Status: **PASS**
Ratio: **0.130**