

Your Project Calculations



Project Name: MTSOLAR_D85K7LL4IKA5

S3D Model Link:

https://platform.skyciv.com/structural?preload_name=MTSOLAR_D85K7LL4IKA5&preload_path=Shared%20Enterprise%20Folder/MT_Solar_Projects/6_2023

Public Model Link:

https://platform.skyciv.com/structural-viewer?project_id=Modv0oSiX2jZIMwQb8O2riCRqOyJ6exduavhXDai6RxzjNC7ZyflGZUsdBvmW47w

Array Specification

Product:	Beam
Unique ID:	1P-0-6TOP-SD-24-L-3Hx2W-0J9G
Duty Classification:	SD
Module Width:	41.26 in
Module Length:	69.37in
Number of Rows:	3
Number of Columns:	2
Total Number of Modules:	6
Desired Tilt Angle:	38
Front Edge Clearance:	5
Total Array Height at Tilt:	11.39 ft
Total Frame Length:	11.50 ft
Frame Weight:	514 lbs
Array Dimensions N/S:	10.44 ft
Array Dimensions E/W:	11.73 ft
Rail Length:	125.28 in
Rail Spacing:	2.89 ft
Rail Check:	Not Checked

Support Specifications

Pole Size:	6in Pipe Sch 40
Pole Length above Grade:	8.21 ft
Number of Poles:	1
Pole Spacing:	0

Foundation Specifications

Foundation Type:	Square
Foundation Dimensions:	48 x 48 in
Foundation Depth (below grade):	Pile 1: 5.00 ft
Foundation Volume:	2.963 y ³
Foundation Result:	PASSED
Mount Twist:	0.000002 kip

Site Info

Risk Category:	I
Exposure:	C
Soil Classification:	sand
Site Location:	12500 Jeremy Ranch Rd, Park City, UT 84098, USA
Wind Speed:	115 mph
Snow Load:	97 psf
Design Uplift Pressure:	Multiple pressures
Design Downforce Pressure:	Multiple pressures
Design Snow Pressure:	0.034133 ksf



Design Disclaimer

This software should be used for preliminary designs and should not be used as a final design unless reviewed, verified and designed by a qualified structural engineer.

AutoDesigner Input

```
{
  "product_type": "Beam",
  "project_id": "MTSOLAR_D85K7LL4IKA5",
  "site_address": "12500 Jeremy Ranch Rd, Park City, UT 84098, USA",
  "module_width": 41.26,
  "module_length": 69.37,
  "number_rows": 3,
  "number_columns": 2,
  "pole_mount_section": "4_40",
  "core_pipe_width": 65,
  "core_pipe_section": "2_40",
  "adjuster_section": "2_40",
  "core_beam_height": 65,
  "core_beam_section": "HSS3x2x1/8",
  "main_pipe_section": "2_12GA",
  "pole_spacing": 15,
  "tilt_angle": 38,
  "ground_clearance": 5,
  "risk_category": "I",
  "exposure_category": "C",
  "frame_duty_override": "auto",
  "pole_override": "auto",
  "soil_type": "sand",
  "foundation_type": "Square",
  "foundation_size": 48,
  "check_rails": false,
  "wind_speed_override": 115,
  "snow_load_override": 97,
  "direct_snow_load": false
}
```

Design Notes:

- AISC Deflection checks are set to L/1 due to structure design intent
- Foundation Design and Sizing is approximate only

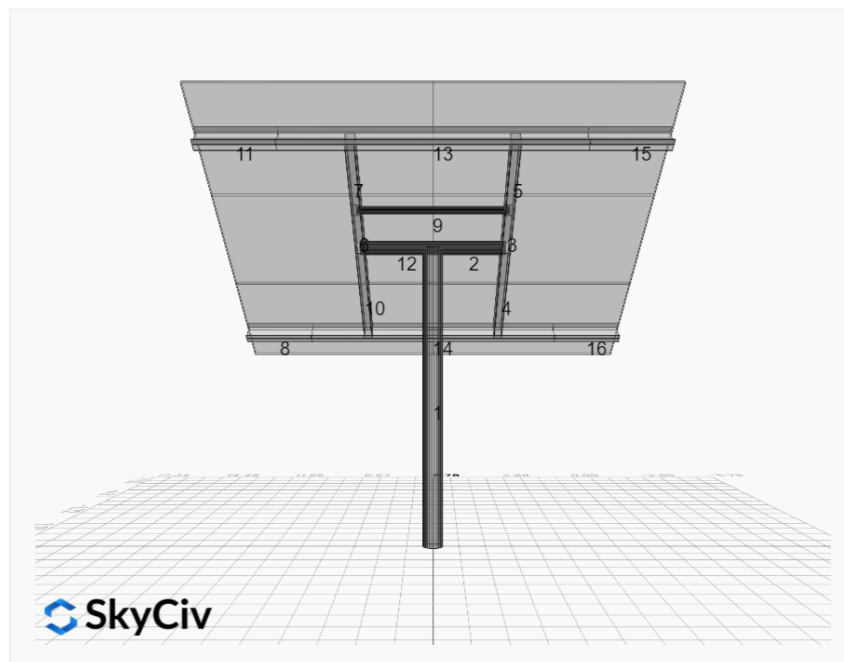

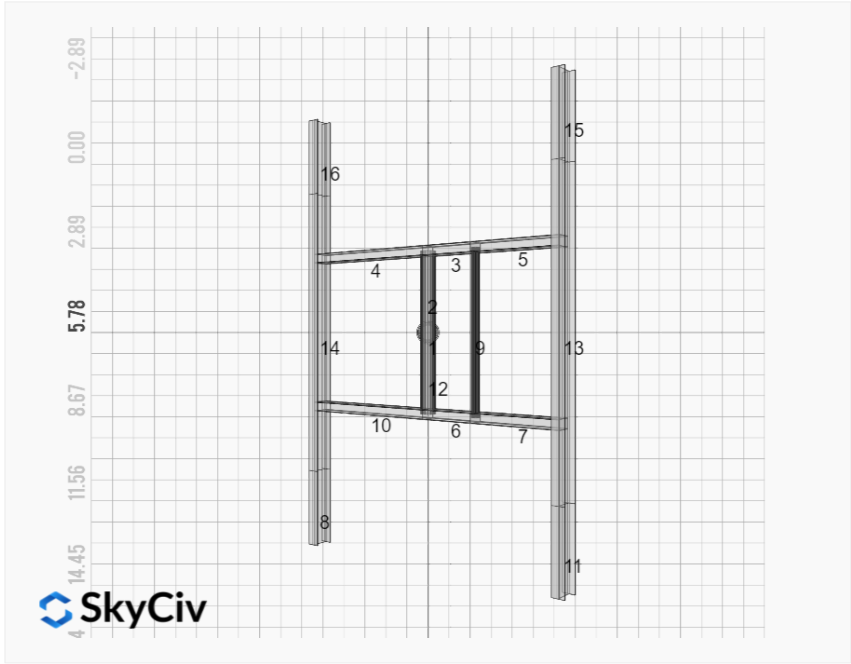
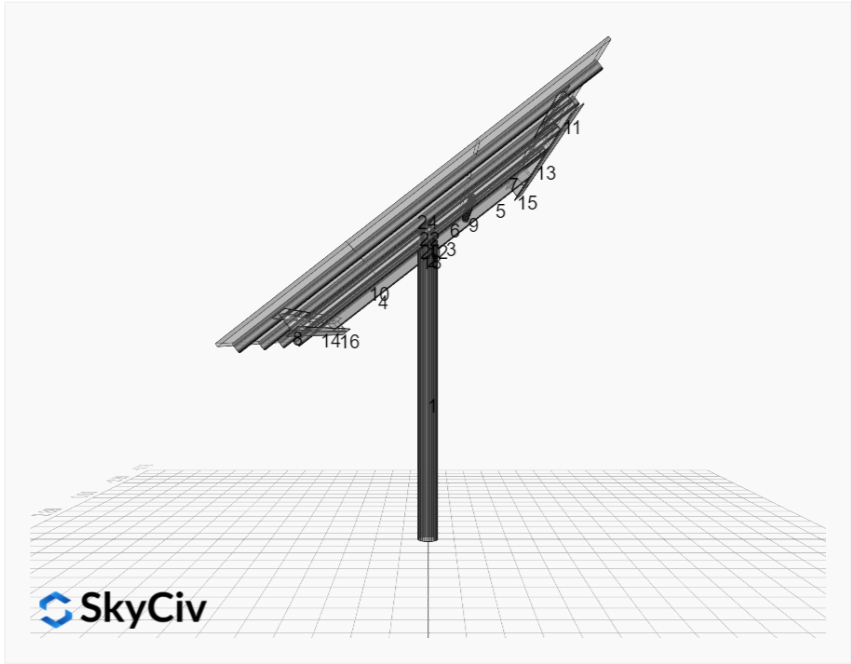

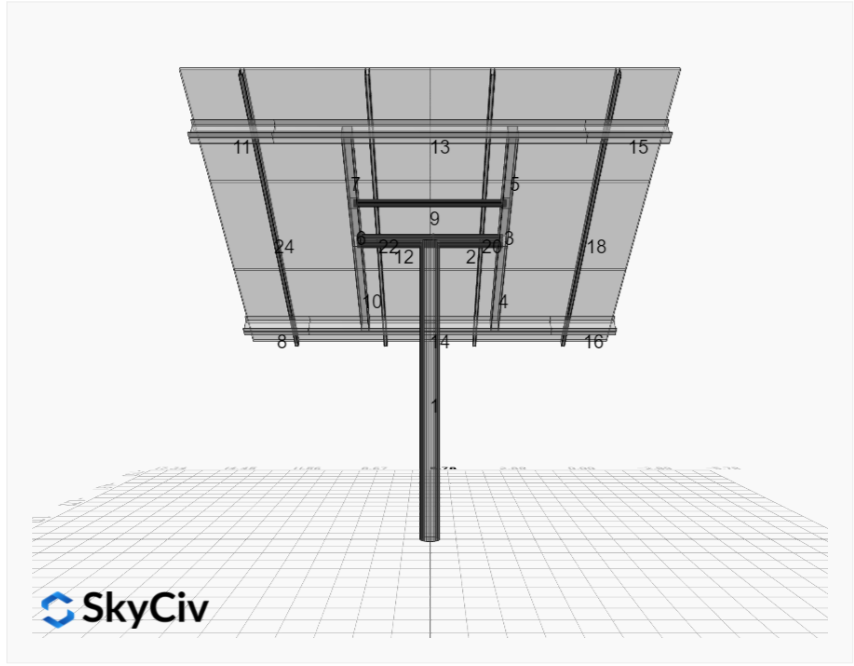
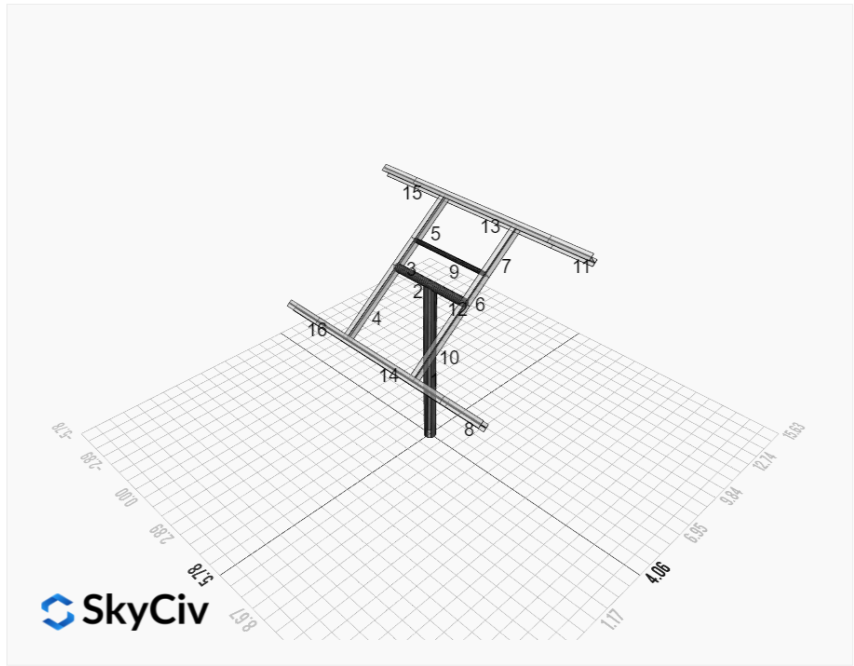

FEM Results (Envelope Worst Case for each member)

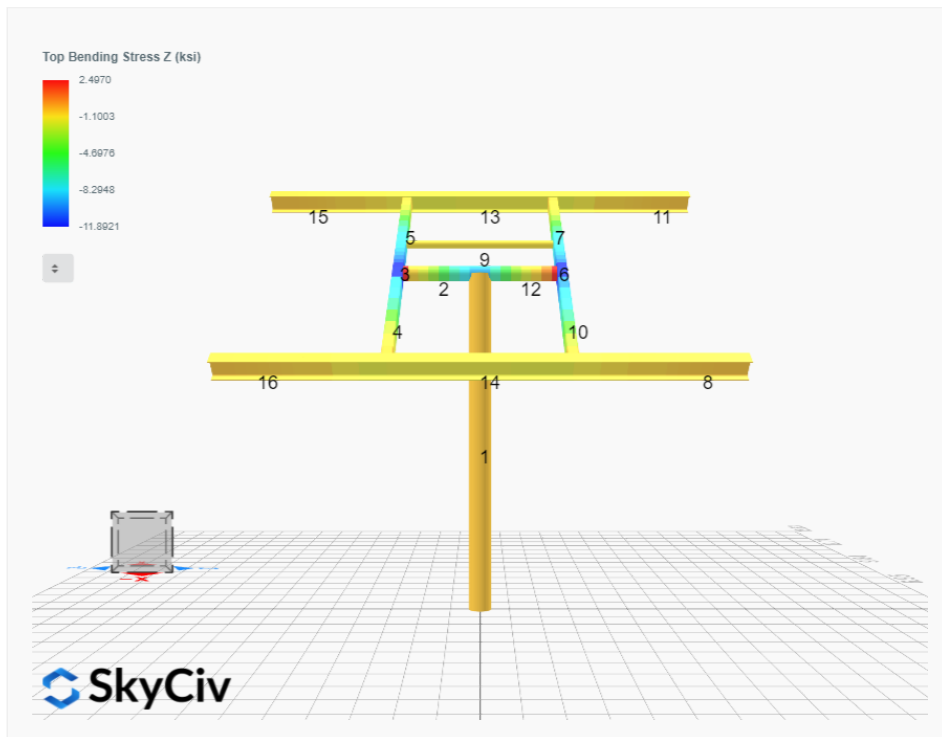
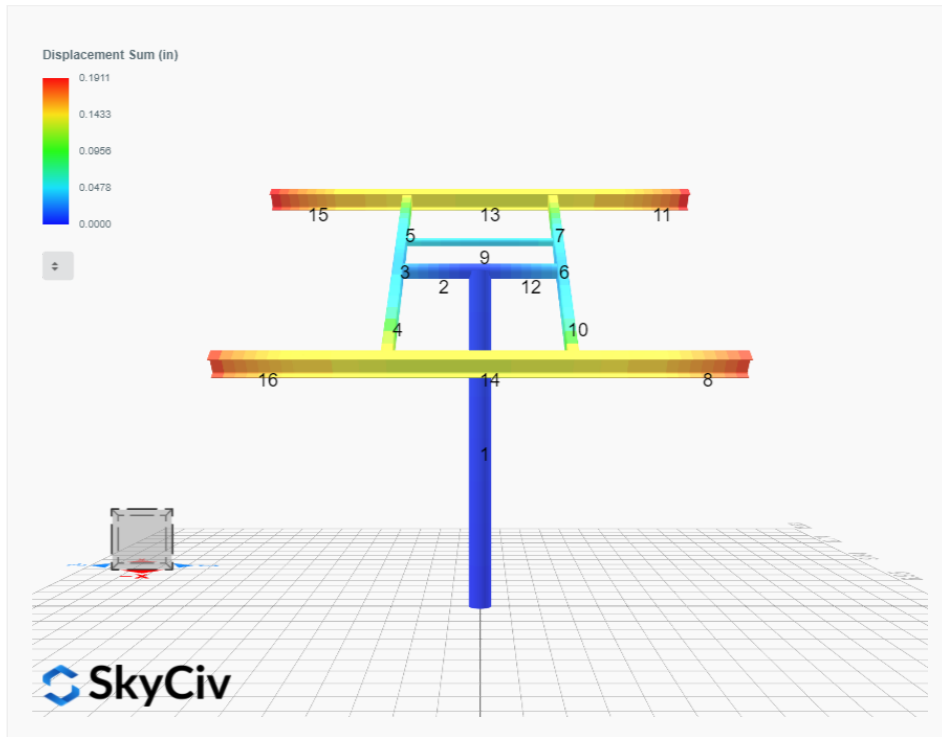

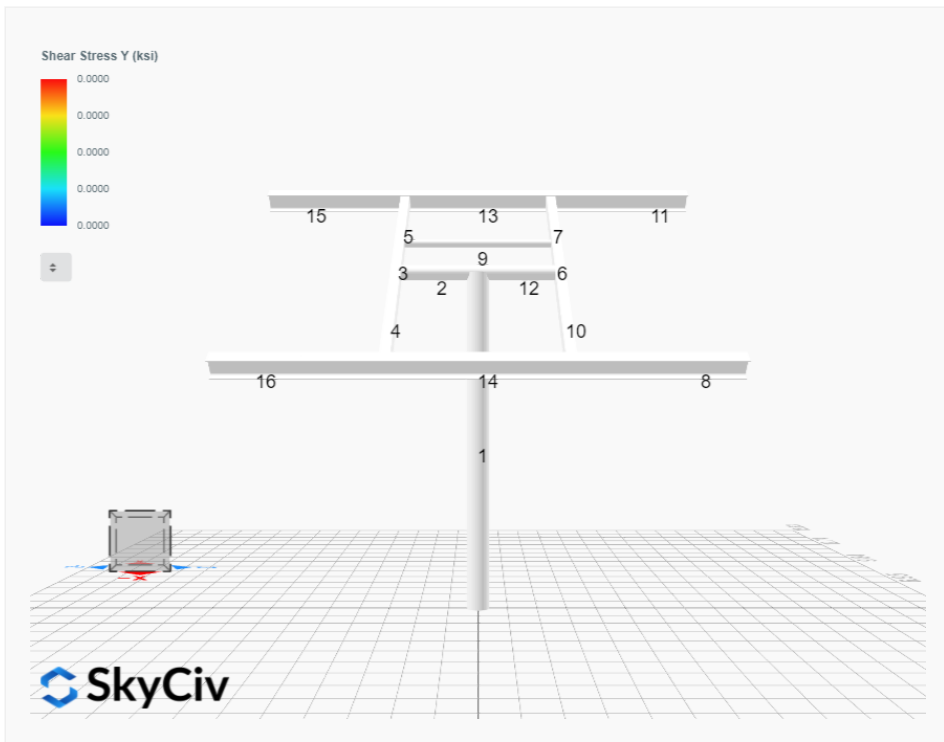
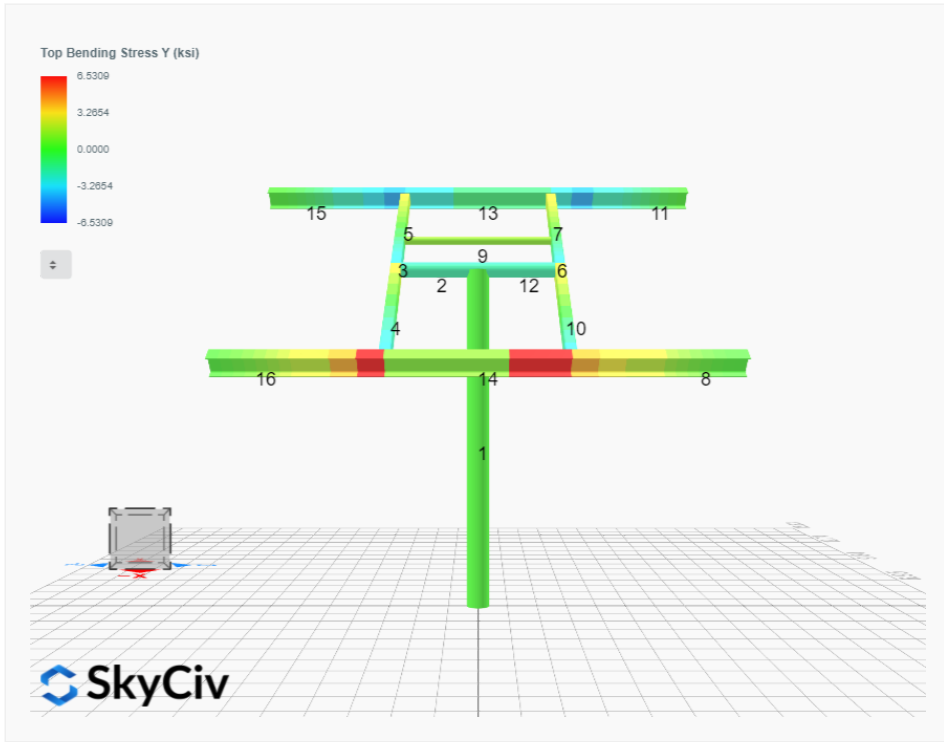

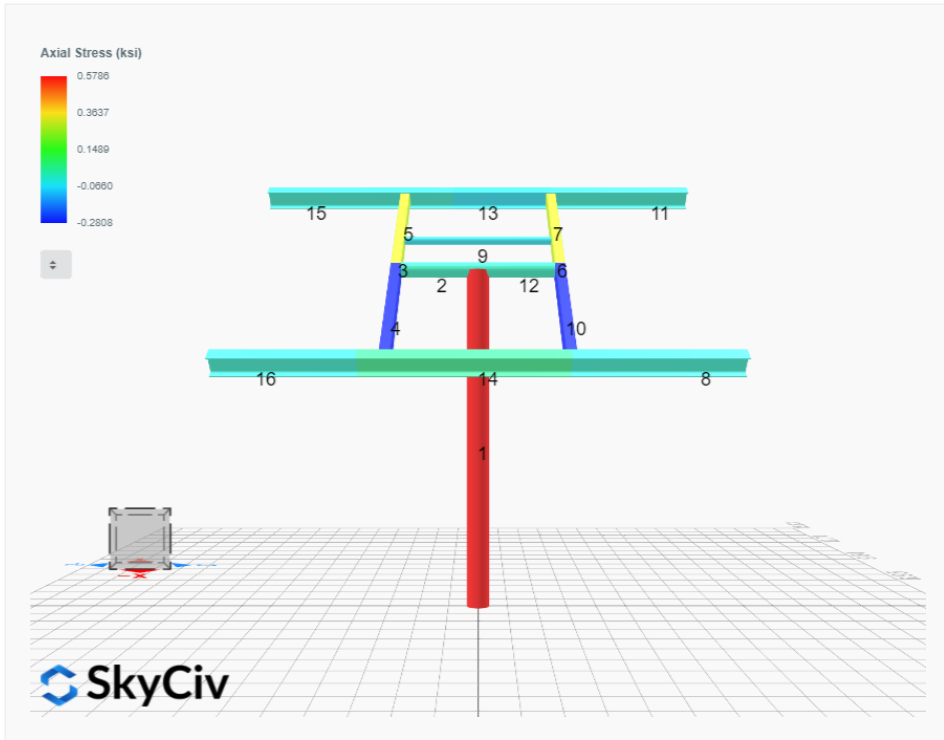

Reaction Forces for Foundation 1 (Node ID#1), (kip, kip-ft)

ASD Load Combination Results

Name	Fx	Fy	Fz	Mx	My	Mz
ULS: 1. D	0.0000	1.1237	0.0000	0.0000	-0.0000	0.0171
ULS: 2. D + L	0.0000	1.1237	0.0000	0.0000	-0.0000	0.0171
ULS: 3. D + (S or Lr or R)	0.0000	4.3529	0.0000	0.0000	-0.0000	0.0358
ULS: 3. D + (S or Lr or R)	0.0000	1.1237	0.0000	0.0000	-0.0000	0.0171
ULS: 4. D + 0.75L + 0.75(S or Lr or R)	0.0000	3.5456	0.0000	0.0000	-0.0000	0.0311
ULS: 4. D + 0.75L + 0.75(S or Lr or R)	0.0000	1.1237	0.0000	0.0000	-0.0000	0.0171
ULS: 5b. D + 0.7E	0.0000	1.1237	0.0000	0.0000	-0.0000	0.0171
ULS: 6b. D + 0.75L + 0.75(0.7)E + 0.75S	0.0000	3.5456	0.0000	0.0000	-0.0000	0.0311
ULS: 8. 0.6D + 0.7E	0.0000	0.6742	0.0000	0.0000	-0.0000	0.0103
ULS: 5a. D + 0.6W_Wind downforce Case A only	-1.6296	3.2095	-0.0000	0.0000	-0.0000	13.8557
ULS: 5a. D + 0.6W_Wind downforce Case B only	-1.6296	3.2095	-0.0000	0.0000	-0.0000	13.8557
ULS: 5a. D + 0.6W_Wind uplift Case A only	1.3509	-0.6054	-0.0000	0.0000	-0.0000	-10.9236
ULS: 5a. D + 0.6W_Wind uplift Case B only	1.1299	-0.3226	0.0000	0.0000	-0.0000	-13.2169
ULS: 6a. D + 0.75L + 0.75(0.6)W + 0.75(S or Lr or R)_Wind downforce Case A only	-1.2222	5.1100	0.0000	0.0000	-0.0000	10.4101
ULS: 6a. D + 0.75L + 0.75(0.6)W + 0.75(S or Lr or R)_Wind downforce Case B only	-1.2222	5.1100	0.0000	0.0000	-0.0000	10.4101
ULS: 6a. D + 0.75L + 0.75(0.6)W + 0.75(S or Lr or R)_Wind uplift Case A only	1.0132	2.2488	0.0000	0.0000	-0.0000	-8.1744
ULS: 6a. D + 0.75L + 0.75(0.6)W + 0.75(S or Lr or R)_Wind uplift Case B only	0.8475	2.4609	0.0000	0.0000	-0.0000	-9.8944
ULS: 6a. D + 0.75L + 0.75(0.6)W + 0.75(S or Lr or R)_Wind downforce Case A only	-1.2222	2.6881	-0.0000	0.0000	-0.0000	10.3961
ULS: 6a. D + 0.75L + 0.75(0.6)W + 0.75(S or Lr or R)_Wind downforce Case B only	-1.2222	2.6881	-0.0000	0.0000	-0.0000	10.3961
ULS: 6a. D + 0.75L + 0.75(0.6)W + 0.75(S or Lr or R)_Wind uplift Case A only	1.0132	-0.1731	-0.0000	0.0000	-0.0000	-8.1884
ULS: 6a. D + 0.75L + 0.75(0.6)W + 0.75(S or Lr or R)_Wind uplift Case B only	0.8475	0.0390	0.0000	0.0000	-0.0000	-9.9084
ULS: 7. 0.6D + 0.6W_Wind downforce Case A only	-1.6296	2.7600	-0.0000	0.0000	-0.0000	13.8489
ULS: 7. 0.6D + 0.6W_Wind downforce Case B only	-1.6296	2.7600	-0.0000	0.0000	-0.0000	13.8489
ULS: 7. 0.6D + 0.6W_Wind uplift Case A only	1.3509	-1.0549	-0.0000	0.0000	-0.0000	-10.9305
ULS: 7. 0.6D + 0.6W_Wind uplift Case B only	1.1299	-0.7720	0.0000	0.0000	-0.0000	-13.2238

Worst Case Reactions LRFD

These calculations are taken directly from the FEA via SkyCiv and are used in the Concrete Checks of the Foundation Module.
Note: Worst case values are assumed as downforce wind load cases.

Result	Value (kip, kip-ft)
Axial	8.2534
Shear X	-2.7160
Shear Z	-0.0000
Moment X	-0.0000
Moment Y (Twist)	0.0000
Moment Z	23.4082

Worst Case Reactions ASD

These results are taken from the worst case values in the above table and are used in the Soil Checks in the Foundation Module.
Note: Worst case values are assumed as downforce wind load cases.

Result	Value (kip, kip-ft)
Axial	5.1100
Shear X	-1.6296
Shear Z	0.0000
Moment X	0.0000
Moment Y (Twist)	0.0000
Moment Z	13.8557

Project Details

Design Code: AISC 360-16 LRFD
 Provision: LRFD
 Country: United States
 User Name: sales@mtsolar.us
 Unit System: imperial



Design Input Information

Design Factors			
Φ_t	Φ_c	Φ_b	Φ_v
0.9	0.9	0.9	0.9

Design Materials			
ID	E (ksi)	F_y (ksi)	F_u (ksi)
1	29000	50	65

Section Dimensions



ID	Name	d (in)	t_w (in)				
1	2in Pipe Sch 40	2.38	0.15				
4	4in Pipe Sch 40	4.50	0.24				
7	6in Pipe Sch 40	6.63	0.28				



ID	Name	d (in)	b (in)	t_w (in)	t_b (in)	r (in)	
15	HSS5x3x1/8	5.00	3.00	0.12	0.12	0.12	



ID	Name	d (in)	t_w (in)	b_t (in)	b_b (in)	t_t (in)	t_b (in)	r (in)
18	W6x9	5.90	0.17	3.94	3.94	0.21	0.21	0.25

Section Properties

ID	Name	A (in ²)	J (in ⁴)	I_{yp} (in ⁴)	I_{zp} (in ⁴)	I_w (in ⁶)	S_{yp} (in ³)	S_{zp} (in ³)
1	2in Pipe Sch 40	1.07	1.33	0.67	0.67	0.00	0.76	0.76
4	4in Pipe Sch 40	3.17	14.47	7.23	7.23	0.00	4.31	4.31
7	6in Pipe Sch 40	5.58	56.28	28.14	28.14	0.00	11.28	11.28

11	120.60	96.18	23.36	6.45	30.09	45.74
12	142.83	141.72	16.17	16.17	42.85	42.85
13	120.60	98.23	19.01	6.45	30.09	45.74
14	120.60	98.23	18.49	6.45	30.09	45.74
15	120.60	96.18	23.36	6.45	30.09	45.74
16	120.60	96.18	23.36	6.45	30.09	45.74

Design Ratio

Member ID	P	M _z	M _y	V _y	V _z	(P,M _z ,M _y)	Worst LC	KL/r	δ	Status
1	0.061	0.553	0.000	0.036	0.000	0.577	#13	0.461	Not Required	Pass
2	0.001	0.405	0.171	0.094	0.032	0.530	#21	0.052	Not Required	Pass
3	0.013	0.616	0.166	0.062	0.029	0.789	#21	0.044	Not Required	Pass
4	0.012	0.601	0.160	0.061	0.023	0.754	#21	0.078	Not Required	Pass
5	0.013	0.383	0.158	0.061	0.021	0.409	#21	0.073	Not Required	Pass
6	0.013	0.616	0.166	0.062	0.029	0.789	#21	0.044	Not Required	Pass
7	0.013	0.383	0.158	0.061	0.021	0.409	#21	0.073	Not Required	Pass
8	0.000	0.026	0.051	0.020	0.007	0.077	#21	Not Required	Not Required	Pass
9	0.003	0.044	0.044	0.001	0.000	0.089	#21	0.132	Not Required	Pass
10	0.012	0.601	0.160	0.061	0.023	0.754	#21	0.078	Not Required	Pass
11	0.000	0.026	0.051	0.021	0.007	0.078	#21	Not Required	Not Required	Pass
12	0.001	0.405	0.171	0.094	0.032	0.530	#21	0.052	Not Required	Pass
13	0.003	0.127	0.180	0.039	0.013	0.293	#21	0.177	Not Required	Pass
14	0.004	0.129	0.180	0.038	0.013	0.291	#21	0.177	Not Required	Pass
15	0.000	0.026	0.051	0.021	0.007	0.078	#21	Not Required	Not Required	Pass
16	0.000	0.026	0.051	0.020	0.007	0.077	#21	Not Required	Not Required	Pass

Definitions

Φ _t	Safety factor for tensile
Φ _c	Safety factor for compression
Φ _b	Safety factor for flexure
Φ _v	Safety factor for shear
E	Modulus of elasticity
F _y	Specified minimum yield stress
F _u	Specified minimum tensile strength
A	Cross-sectional area
J	Torsional constant
I _{yp}	Moment of inertia about the Y axes
I _{zp}	Moment of inertia about the Z axes
I _w	Warping constant
S _{yp}	Plastic section modulus about the Y axis
S _{zp}	Plastic section modulus about the Z axis
KL	Effective length
C _b	Buckling modification factor (from all load combinations)
L _b	Length between braced points
LST	Limited slenderness for tension
LSC	Limited slenderness for compression
LD	Limited deflection
P _n	Nominal axial strength (tension/compression)
M _n	Nominal flexural strength (about Z/Y axis)
V _n	Nominal shear strength (along Z/Y axis)
P	Design ratio in case of axial force
M _z	Design ratio in case of bending about Z axis
M _y	Design ratio in case of bending about Y axis
V _y	Design ratio in case of shear along Y axis
V _z	Design ratio in case of shear along Z axis
(P,M _z ,M _y)	Design ratio in case of axial force and bending action
KL/r	Design ratio in case of section slenderness
δ	Design ratio in case of member deflection
OK	Capacity is provided
NG	Capacity is not provided

no capacity is not provided

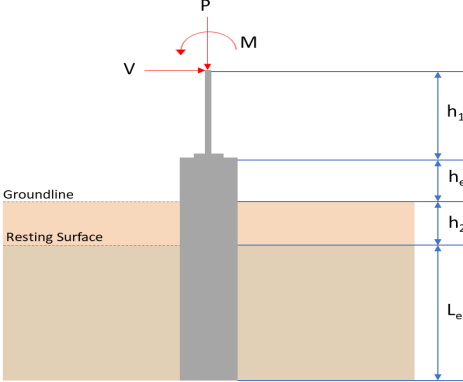
REFERENCES	CALCULATIONS	RESULTS																										
	<p>SkyCiv Foundation Design Pile Foundation</p> <p>Design Information : Design code : IBC 2021 (International Building Code) Unit System : Imperial</p>																											
	<p>Pile Input</p>  <p>Geometry Pile shape: rectangular $b = 48$ in - Pile width $D = 48$ in - Pile depth $L = 5$ ft - Total pile length $h_1 = 0$ ft - Lateral load height from the top of the pile, $h_2 = 0$ ft - Depth to resting surface $h_e = 0$ ft - Length of pile above the ground</p> <p>Tabulation of Soil Parameters</p> <table border="1" data-bbox="416 1102 1193 1193"> <thead> <tr> <th>Layer</th> <th>Label</th> <th>Allowable Bearing Pressure (q_a) (psf)</th> <th>Allowable Lateral Pressure (R) (psf/ft)</th> </tr> </thead> <tbody> <tr> <td>1</td> <td>Sand, silty sand, clayey sand, silty gravel & clayey gravel</td> <td>2000.000</td> <td>150.000</td> </tr> </tbody> </table> <p>Tabulation of Loads</p> <table border="1" data-bbox="676 1288 933 1458"> <thead> <tr> <th>Load Component</th> <th>ASD</th> <th>LRFD</th> </tr> </thead> <tbody> <tr> <td>P (kip)</td> <td>5.110</td> <td>8.253</td> </tr> <tr> <td>V_x (kip)</td> <td>-1.630</td> <td>-2.716</td> </tr> <tr> <td>V_z (kip)</td> <td>0.000</td> <td>0.000</td> </tr> <tr> <td>M_x (kipft)</td> <td>0.000</td> <td>0.000</td> </tr> <tr> <td>M_z (kipft)</td> <td>13.856</td> <td>23.408</td> </tr> </tbody> </table> <p>Material Properties $f'_{ck} = 2.5$ ksi - Concrete strength,</p>	Layer	Label	Allowable Bearing Pressure (q_a) (psf)	Allowable Lateral Pressure (R) (psf/ft)	1	Sand, silty sand, clayey sand, silty gravel & clayey gravel	2000.000	150.000	Load Component	ASD	LRFD	P (kip)	5.110	8.253	V_x (kip)	-1.630	-2.716	V_z (kip)	0.000	0.000	M_x (kipft)	0.000	0.000	M_z (kipft)	13.856	23.408	
Layer	Label	Allowable Bearing Pressure (q_a) (psf)	Allowable Lateral Pressure (R) (psf/ft)																									
1	Sand, silty sand, clayey sand, silty gravel & clayey gravel	2000.000	150.000																									
Load Component	ASD	LRFD																										
P (kip)	5.110	8.253																										
V_x (kip)	-1.630	-2.716																										
V_z (kip)	0.000	0.000																										
M_x (kipft)	0.000	0.000																										
M_z (kipft)	13.856	23.408																										
	<p>Required depth to resist lateral loads (ASD) H - Point of application of the lateral load</p> $H = h_1 + h_2 + h_e$ $H = (0 \text{ ft}) + (0 \text{ ft}) + (0 \text{ ft})$ $H = 0 \text{ ft}$ <p>Considering x-direction: H_o - Lateral force per length of pile,</p> $H_o = \frac{V_x}{1.57 D}$ $H_o = \frac{(-1.63 \text{ kip})}{1.57 \times (48 \text{ in})}$ $H_o = -0.25955 \text{ kip/ft}$ <p>M_o - Moment per length of pile,</p> $M_o = \frac{M_z + (V_x H)}{1.57 D}$																											

	$M_o = \frac{(13.856 \text{ kipft}) + ((-1.63 \text{ kip}) \times (0 \text{ ft}))}{1.57 \times (48 \text{ in})}$ $M_o = 2.2064 \text{ kipft/ft}$ <p>Required depth of embedment in earth:</p> $L_x^3 - \left(14.14 \times \frac{H_o \times L_x}{R}\right) - \left(18.85 \times \frac{M_o}{R}\right) = 0$ <p>Solving the cubic equation: $L_{e,x} = 4.6938 \text{ ft}$ - Required depth in x-direction,</p> <p>Considering z-direction: $L_{e,z} = 0 \text{ ft}$ - Required depth in z-direction,</p> <p>Minimum embedded depth required: $L_{e,req}$ - Depth of pile required,</p> $L_{e,req} = \text{MAX}[L_{e,x}, L_{e,z}]$ $L_{e,req} = \text{MAX}[(4.6938 \text{ ft}), (0 \text{ ft})]$ $L_{e,req} = 4.694 \text{ ft}$ <p>L_e - Actual embedded length of pile,</p> $L_e = L - h_e - h_2$ $L_e = (5 \text{ ft}) - (0 \text{ ft}) - (0 \text{ ft})$ $L_e = 5 \text{ ft}$ <p><i>Ratio</i> - Embedded depth</p> $\text{Ratio} = \frac{L_{e,req}}{L_e}$ $\text{Ratio} = \frac{(4.694 \text{ ft})}{(5 \text{ ft})}$ $\text{Ratio} = 0.9388$	<p>Status: PASS Ratio: 0.940</p>
	<p>End-bearing Capacity (ASD)</p> <p>A - Pile cross-section area</p> $A = b D$ $A = (48 \text{ in}) \times (48 \text{ in})$ $A = 16 \text{ ft}^2$ <p>q - End-bearing pressure</p> $q = \frac{P_v}{A}$ $q = \frac{(5.11 \text{ kip})}{(16 \text{ ft}^2)}$ $q = 0.31938 \text{ kip/ft}^2$ <p>Check bearing capacity ratio:</p> <p><i>Ratio</i> - Capacity</p> $\text{Ratio} = \frac{q}{q_o}$ $\text{Ratio} = \frac{(0.31938 \text{ kip/ft}^2)}{(2000 \text{ psf})}$ $\text{Ratio} = 0.15969$	<p>Status: PASS Ratio: 0.160</p>
<p>Czerniak</p>	<p>Lateral Soil Pressure (ASD):</p> <p>L/D - Length to least lateral dimension ratio,</p> $L/D = \frac{L}{D}$ $L/D = \frac{(5 \text{ ft})}{(48 \text{ in})}$	

$$L/D = 1.25$$

Since $L/D \leq 10$,

Pile is short.

Considering x-direction:

$H_o = -0.25955$ kip/ft - Lateral force per length of pile,

$M_o = 2.2064$ kipft/ft - Overturning moment per length of pile,

a - Distance from resting surface to pivot point,

$$a = \frac{(4 M_o L_e) + (3 H_o L_e^2)}{(6 M_o) + (4 H_o L_e)}$$

$$a = \frac{(4 \times (2.2064 \text{ kipft/ft}) \times (5 \text{ ft})) + (3 \times (-0.25955 \text{ kip/ft}) \times (5 \text{ ft})^2)}{(6 \times (2.2064 \text{ kipft/ft})) + (4 \times (-0.25955 \text{ kip/ft}) \times (5 \text{ ft}))}$$

$$a = 3.4507 \text{ ft}$$

p - Earth pressure against the pile at distance $a/2$ from resting surface,

$$p = \frac{0.75 [(4 M_o) + (3 H_o L_e)]^2}{L_e^2 [(3 M_o) + (2 H_o L_e)]}$$

$$p = \frac{0.75 \times [(4 \times (2.2064 \text{ kipft/ft})) + (3 \times (-0.25955 \text{ kip/ft}) \times (5 \text{ ft}))]^2}{(5 \text{ ft})^2 \times [(3 \times (2.2064 \text{ kipft/ft})) + (2 \times (-0.25955 \text{ kip/ft}) \times (5 \text{ ft}))]}$$

$$p = 0.18138 \text{ kip/ft}^2$$

s - Earth pressure against the pile at distance L_e ,

$$s = \frac{6 [(2 M_o) + (H_o L_e)]}{L_e^2}$$

$$s = \frac{6 \times [(2 \times (2.2064 \text{ kipft/ft})) + ((-0.25955 \text{ kip/ft}) \times (5 \text{ ft}))]}{(5 \text{ ft})^2}$$

$$s = 0.74759 \text{ kip/ft}^2$$

Check lateral soil pressure capacity:

p_a - Allowable lateral soil pressure at depth $a/2$,

$$p_a = R \frac{a}{2}$$

$$p_a = (150 \text{ psf/ft}) \times \frac{(3.4507 \text{ ft})}{2}$$

$$p_a = 0.2588 \text{ kip/ft}^2$$

Ratio - Lateral soil capacity

$$\text{Ratio} = \frac{p}{p_a}$$

$$\text{Ratio} = \frac{(0.18138 \text{ kip/ft}^2)}{(0.2588 \text{ kip/ft}^2)}$$

$$\text{Ratio} = 0.70084$$

p_s - Allowable lateral soil pressure at depth L_e ,

$$p_s = R L_e$$

$$p_s = (150 \text{ psf/ft}) \times (5 \text{ ft})$$

$$p_s = 0.75 \text{ kip/ft}^2$$

Ratio - Lateral soil capacity

$$\text{Ratio} = \frac{s}{p_s}$$

$$\text{Ratio} = \frac{(0.74759 \text{ kip/ft}^2)}{(0.75 \text{ kip/ft}^2)}$$

$$\text{Ratio} = 0.9968$$

Status: **PASS**
Ratio: **0.700**

Status: **PASS**
Ratio: **1.000**

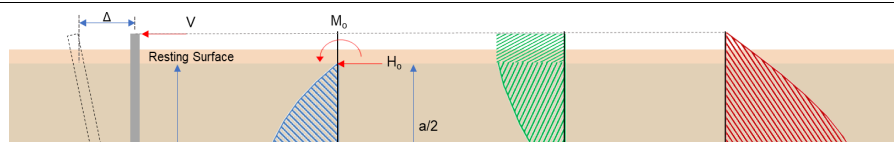



Shear force and Bending moment (x-direction, LRFD)

H_o - Lateral force per length of pile,

$$H_o = \frac{V_x}{1.57 D}$$

$$H_o = \frac{(-2.716 \text{ kip})}{1.57 \times (48 \text{ in})}$$

$$H_o = -0.43248 \text{ kip/ft}$$

M_o - Moment per length of pile,

$$M_o = \frac{M_x + (V_x H)}{1.57 D}$$

$$M_o = \frac{(23.408 \text{ kipft}) + ((-2.716 \text{ kip}) \times (0 \text{ ft}))}{1.57 \times (48 \text{ in})}$$

$$M_o = 3.7274 \text{ kipft/ft}$$

E - Distance from lateral load to resisting surface,

$$E = \frac{M_o}{H_o}$$

$$E = \frac{(3.7274 \text{ kipft/ft})}{(-0.43248 \text{ kip/ft})}$$

$$E = 8.6186 \text{ ft}$$

a - Distance from resting surface to pivot point,

$$a = \frac{(4 M_o L_c) + (3 H_o L_c^2)}{(6 M_o) + (4 H_o L_c)}$$

$$a = \frac{(4 \times (3.7274 \text{ kipft/ft}) \times (5 \text{ ft})) + (3 \times (-0.43248 \text{ kip/ft}) \times (5 \text{ ft})^2)}{(6 \times (3.7274 \text{ kipft/ft})) + (4 \times (-0.43248 \text{ kip/ft}) \times (5 \text{ ft}))}$$

$$a = 3.4495 \text{ ft}$$

V_{max} - Max shear force located at depth a ,

$$V_{max} = (H_o D) \left[1 - \left[3 \left(\frac{4 E}{L_c} + 3 \right) \left(\frac{a}{L_c} \right)^2 \right] + \left[4 \left(\frac{3 E}{L_c} + 2 \right) \left(\frac{a}{L_c} \right)^3 \right] \right]$$

$$V_{max} = ((-0.43248 \text{ kip/ft}) \times (48 \text{ in})) \times \left[1 - \left[3 \times \left(\frac{4 \times (8.6186 \text{ ft})}{(5 \text{ ft})} + 3 \right) \times \left(\frac{(3.4495 \text{ ft})}{(5 \text{ ft})} \right)^2 \right] + \left[4 \times \left(\frac{3 \times (8.6186 \text{ ft})}{(5 \text{ ft})} + 2 \right) \times \left(\frac{(3.4495 \text{ ft})}{(5 \text{ ft})} \right)^3 \right] \right]$$

$$V_{max} = 6.4175 \text{ kip}$$

M_{max} - Max bending moment located at depth $a/2$,

$$M_{max} = (H_o D L_c) \left[\left(\frac{E}{L_c} + \frac{a}{2 L_c} \right) - \left[\left(\frac{4 E}{L_c} + 3 \right) \left(\frac{a}{2 L_c} \right)^3 \right] + \left[\left(\frac{3 E}{L_c} + 2 \right) \left(\frac{a}{2 L_c} \right)^4 \right] \right]$$

$$M_{max} = ((-0.43248 \text{ kip/ft}) \times (48 \text{ in}) \times (5 \text{ ft})) \times \left[\left(\frac{(8.6186 \text{ ft})}{(5 \text{ ft})} + \frac{(3.4495 \text{ ft})}{2 \times (5 \text{ ft})} \right) - \left[\left(\frac{4 \times (8.6186 \text{ ft})}{(5 \text{ ft})} + 3 \right) \times \left(\frac{(3.4495 \text{ ft})}{2 \times (5 \text{ ft})} \right)^3 \right] + \left[\left(\frac{3 \times (8.6186 \text{ ft})}{(5 \text{ ft})} + 2 \right) \times \left(\frac{(3.4495 \text{ ft})}{2 \times (5 \text{ ft})} \right)^4 \right] \right]$$

$$M_{max} = 15.258 \text{ kipft}$$

Minimum Reinforcement Check (LRFD)

Parameters:

$f'_{ck} = 2.5 \text{ ksi}$ - Concrete strength,
 $f_{yk} = 60 \text{ ksi}$ - Longitudinal reinforcement strength,
 $\phi = 0.65$ - Reduction factor for axial strength,
 $\alpha = 0.8$ - Alpha factor for axial strength,
 $A_g = 2304 \text{ in}^2$ - Gross area of concrete,

Table 22.4.2.1

Longitudinal reinforcement:

Required reinforcement due to axial load, $A_{st,required}$

22.4.2.2, 10.6.1.1

$A_{st,required}$

$$A_{st,required} = \text{Min} \left[\frac{\frac{P}{\phi \alpha} - (0.85 f'_{ck} A_g)}{f_{yk} - (0.85 f'_{ck})}, (0.08 A_g) \right]$$

$$A_{st,required} = \text{Min} \left[\frac{\frac{(8.253 \text{ kip})}{(0.65) \times (0.8)} - (0.85 \times (2.5 \text{ ksi}) \times (2304 \text{ in}^2))}{(60 \text{ ksi}) - (0.85 \times (2.5 \text{ ksi}))}, (0.08 \times (2304 \text{ in}^2)) \right]$$

$$A_{st,required} = -84.322 \text{ in}^2$$

A_{min} - Governing minimum reinforcement area,

$$A_{min} = \text{Max} [A_{st,required}, (0.0018 A_g)]$$

$$A_{min} = \text{Max} [(-84.322 \text{ in}^2), (0.0018 \times (2304 \text{ in}^2))]$$

$$A_{min} = 4.1472 \text{ in}^2$$

n_{rebar} - Required number of reinforcement,

$$n_{rebar} = \frac{A_{min}}{A_{rebar}}$$

$$n_{rebar} = \frac{(4.1472 \text{ in}^2)}{(0.3068 \text{ in}^2)}$$

$$n_{rebar} = 14$$

A_{st} - Actual total reinforcement area,

$$A_{st} = n_{rebar} \frac{\pi d_{bar}^2}{4}$$

$$A_{st} = (14) \times \frac{\pi \times (0.625 \text{ in})^2}{4}$$

$$A_{st} = 4.2951 \text{ in}^2$$

Ratio - Capacity

$$\text{Ratio} = \frac{A_{min}}{A_{st}}$$

$$\text{Ratio} = \frac{(4.1472 \text{ in}^2)}{(4.2951 \text{ in}^2)}$$

$$\text{Ratio} = 0.96556$$

Status: **PASS**
Ratio: **0.970**

25.2.3

s_{rebar} - Minimum spacing of reinforcement,

$$s_{rebar} = \text{Max} [1.5, (1.5 d_{bar})]$$

$$s_{rebar} = \text{Max} [1.5, (1.5 \times (0.625 \text{ in}))]$$

$$s_{rebar} = 1.5 \text{ in}$$

Ties:

25.7.2.2 Since longitudinal reinforcement is \leq No. 10: Use #3(0.375 in)

25.7.2.1

s_{ties} - Maximum spacing of ties,

$$s_{ties} = \text{Min} [(16 d_{bar}), (48 d_{ties}), \text{Min} (D, b)]$$

$$s_{ties} = \text{Min} [(16 \times (0.625 \text{ in})), (48 \times (0.375 \text{ in})), \text{Min} ((48 \text{ in}), (48 \text{ in}))]$$

$$s_{ties} = 10 \text{ in}$$

Summary:

Main reinforcement: **14 - #5 (0.625 in)**

Axial Compression Strength (ACI 318-19, LRFD)22.4.2.2 ϕP_N - Allowable axial compressive strength

$$\phi P_N = \phi 0.80 [(0.85 f'_{ck} [A_g - A_{st}]) + (f_{yk} A_{st})]$$

$$\phi P_N = (0.65) \times 0.80 \times [(0.85 \times (2.5 \text{ ksi}) \times [(2304 \text{ in}^2) - (4.2951 \text{ in}^2)]) + ((60 \text{ ksi}) \times (4.2951 \text{ in}^2))]$$

$$\phi P_N = 2675.2 \text{ kip}$$

Ratio - Capacity

$$\text{Ratio} = \frac{P}{\phi P_N}$$

$$\text{Ratio} = \frac{(8.253 \text{ kip})}{(2675.2 \text{ kip})}$$

$$\text{Ratio} = 0.003085$$

Status: **PASS**
Ratio: **0.000****Shear Strength (ACI 318-19, LRFD)****Parameters:** $b_w = 48 \text{ in}$ - Effective width,22.5.2.2 d - Effective depth

$$d = 0.80 D$$

$$d = 0.80 \times (48 \text{ in})$$

$$d = 38.4 \text{ in}$$

22.5.5.1.3 λ_s - size effect modification factor

$$\lambda_s = \text{MIN} \left[\sqrt{\frac{2}{1 + \frac{d}{10}}}, 1 \right]$$

$$\lambda_s = \text{MIN} \left[\sqrt{\frac{2}{1 + \frac{(38.4 \text{ in})}{10}}}, 1 \right]$$

$$\lambda_s = 0.64282$$

The following variables were converted to be consistent with empirical formula $f'_{ck} = 2.5 \text{ ksi} \rightarrow 2500 \text{ psi}$,22.5.5.1.1 $V_{c,max}$ - Max shear strength of concrete

$$V_{c,max} = 5 \lambda_s \sqrt{f'_{ck}} b_w d$$

$$V_{c,max} = 5 \times (0.64282) \times \sqrt{(2500 \text{ psi})} \times (48 \text{ in}) \times (38.4 \text{ in})$$

$$V_{c,max} = 296.21 \text{ kip}$$

The following variables were converted to be consistent with empirical formula $f'_{ck} = 2.5 \text{ ksi} \rightarrow 2500 \text{ psi}$, $P = 8.253 \text{ kip} \rightarrow 8253 \text{ lbf}$,22.5.5.1.1(a) $V_{c,a}$ - Shear strength of concrete (a)

$$V_{c,a} = \left[2 \lambda_s \sqrt{f'_{ck}} + \frac{P}{6 A_g} \right] b_w d$$

$$V_{c,a} = \left[2 \times (0.64282) \times \sqrt{(2500 \text{ psi})} + \frac{(8253 \text{ lbf})}{6 \times (2304 \text{ in}^2)} \right] \times (48 \text{ in}) \times (38.4 \text{ in})$$

$$V_{c,a} = 119.59 \text{ kip}$$

The following variables were converted to be consistent with empirical formula $f'_{ck} = 2.5 \text{ ksi} \rightarrow 2500 \text{ psi}$,22.5.5.1.2 $V_{c,b}$ - Shear strength of concrete (b)

$$V_{c,b} = \left[2 \lambda_s \sqrt{f'_{ck}} + (0.05 f'_{ck}) \right] b_w d$$

$$V_{c,b} = \left[2 \times (0.64282) \times \sqrt{(2500 \text{ psi})} + (0.05 \times (2500 \text{ psi})) \right] \times (48 \text{ in}) \times (38.4 \text{ in})$$

$$V_{c,b} = 348.89 \text{ kip}$$

 V_c - Governing shear strength of concrete

$$V_c = \text{Min}[V_{c,max}, V_{c,a}, V_{c,b}]$$

$$V_c = \text{Min}[(296.21 \text{ kip}), (119.59 \text{ kip}), (348.89 \text{ kip})]$$

$$V_c = 119.59 \text{ kip}$$

<p>22.5.1.2</p>	<p>The following variables were converted to be consistent with empirical formula $f'_{ck} = 2.5 \text{ ksi} \rightarrow 2500 \text{ psi}$,</p> <p>$V_{s,a}$ - Shear strength of steel (a)</p> $V_{s,a} = 8 \sqrt{f'_{ck}} b_w d$ $V_{s,a} = 8 \times \sqrt{(2500 \text{ psi})} \times (48 \text{ in}) \times (38.4 \text{ in})$ $V_{s,a} = 737.28 \text{ kip}$ <p>A_v - Ties rebar area,</p> $A_v = \frac{\pi d_{ties}^2}{4}$ $A_v = \frac{\pi \times (0.375 \text{ in})^2}{4}$ $A_v = 0.11045 \text{ in}^2$ <p>22.5.8.5.3 $V_{s,b}$ - Shear strength of steel (b)</p> $V_{s,b} = \frac{2 A_v f_{ywk} d}{s_{ties}}$ $V_{s,b} = \frac{2 \times (0.11045 \text{ in}^2) \times (60 \text{ ksi}) \times (38.4 \text{ in})}{(10 \text{ in})}$ $V_{s,b} = 50.894 \text{ kip}$ <p>V_s - Governing shear strength of steel</p> $V_s = \text{MIN}[V_{s,a}, V_{s,b}]$ $V_s = \text{MIN}[(737.28 \text{ kip}), (50.894 \text{ kip})]$ $V_s = 50.894 \text{ kip}$ <p>22.5.1.1 ϕV_n - Allowable shear strength</p> $\phi V_n = \phi (V_c + V_s)$ $\phi V_n = (0.65) \times ((119.59 \text{ kip}) + (50.894 \text{ kip}))$ $\phi V_n = 110.81 \text{ kip}$ <p>Considering x-direction:</p> <p>$V_{max} = 6.4175 \text{ kip}$ - Maximum shear force in the x-direction, Ratio - Capacity</p> $\text{Ratio} = \frac{V_{max}}{\phi V_n}$ $\text{Ratio} = \frac{(6.4175 \text{ kip})}{(110.81 \text{ kip})}$ $\text{Ratio} = 0.057914$	<p>Status: PASS Ratio: 0.060</p>
<p>14.5.2.1b</p>	<p>Flexural Strength (ACI 318-19, LRFD)</p> <p>S_m - Section modulus</p> $S_m = \frac{b D^2}{6}$ $S_m = \frac{(48 \text{ in}) \times (48 \text{ in})^2}{6}$ $S_m = 18432 \text{ in}^3$ <p>$\lambda = 1$ - Concrete modification factor (Normal concrete), Allowable flexural strength: M_n shall be the lesser of:</p> <p>$\phi M_{n,1}$</p> $\phi M_{n,1} = \phi \times 5 \times \lambda \times \sqrt{f'_c} \times S_m$ $\phi M_{n,1} = 0.65 \times 5 \times 1 \times \sqrt{(2.5 \text{ ksi})} \times 18432.001 \text{ in}^3$ $\phi M_{n,1} = 249.600 \text{ kipft}$ <p>$\phi M_{n,2}$</p> $\phi M_{n,2} = 0.85 f'_c S_m$	

$$\phi M_{n,2} = \phi F_y Z_{xk} S_m$$

$$\phi M_{n,2} = (0.65) \times 0.85 \times (2.5 \text{ ksi}) \times (18432 \text{ in}^3)$$

$$\phi M_{n,2} = 2121.6 \text{ kipft}$$

Therefore,

ϕM_n - Allowable flexural strength,

$$\phi M_n = \text{MIN}[\phi M_{n,1}, \phi M_{n,2}]$$

$$\phi M_n = \text{MIN}[(249.6 \text{ kipft}), (2121.6 \text{ kipft})]$$

$$\phi M_n = 249.6 \text{ kipft}$$

Considering x-direction:

$M_{max} = 15.258 \text{ kipft}$ - Maximum moment in the x-direction,

Ratio - Capacity

$$\text{Ratio} = \frac{M_{max}}{\phi M_n}$$

$$\text{Ratio} = \frac{(15.258 \text{ kipft})}{(249.6 \text{ kipft})}$$

$$\text{Ratio} = 0.061132$$

Status: **PASS**
Ratio: **0.060**