

**Project Name:** MTSOLAR\_4F1F0D5F593JE      **Date:** Mon Nov 10 2025  
**Location:** 2222+22 Kettleman City, CA, USA      **Number of Modules:** 12  
**Unique ID:** 1P-0-6TOP-SD-57-L-4Hx3W-F5J6      **Number of Poles:** 1  
**Dealer:** \_\_\_\_\_      **Date Sold:** \_\_\_\_\_

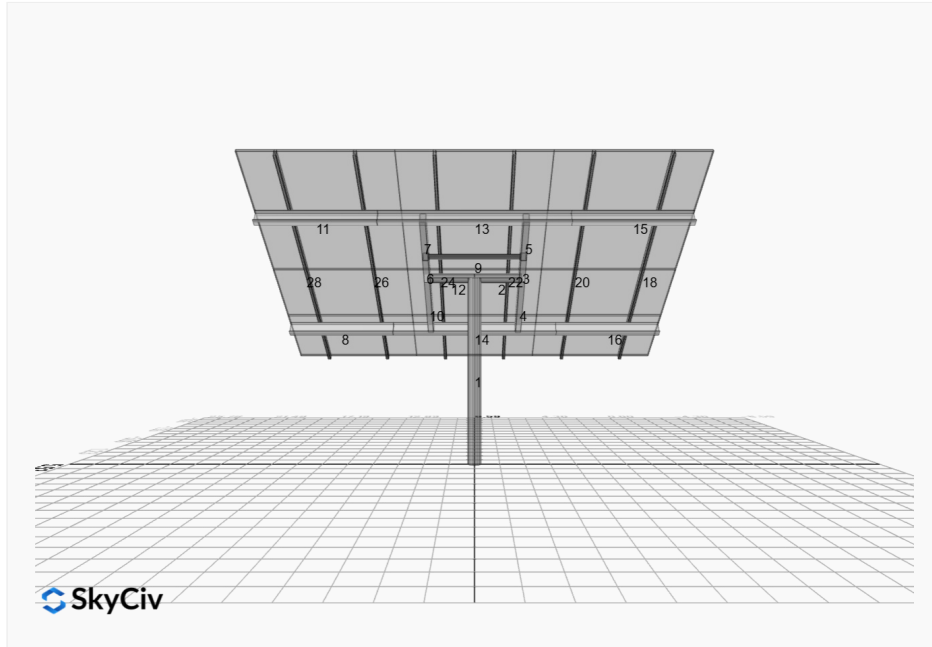

<b>Array Dimensions N/S</b>	13.50 ft
<b>Array Dimensions E/W</b>	17.19 ft
<b>Winter Tilt Angle (Degrees)</b>	35
<b>Front Edge Clearance</b>	4

### MT Solar Bill of Materials (1P-0-6TOP-SD-57-L-4Hx3W-F5J6)

Part	Short Description	BOM Qty
MTS-PC-6	6IN Pole Cap Assembly	1
MTS-HF-SD	H-Frame Assembly-SD	1
MTS-SD-Wing-57	57IN SD Wing	4
MTS-CLAMP-HOOK-4PK	Hook Clamp	3

### Rail Bill of Materials

Part	Qty
Rails (162in Long)	6x
Rail Attachment	12x
Module Mid Clamp	18x
Module End Clamp	12x
Ground Lug	3x

## Site Details:

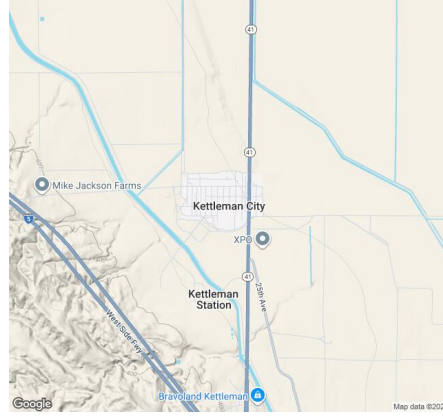

**Site Address:** 2222+22 Kettleman City, CA, USA

### Array Specifications

<b>Duty Classification:</b>	SD
<b>Module Width:</b>	40.00 in
<b>Module Length:</b>	67.75 in
<b>Number of Rows:</b>	4
<b>Number of Columns:</b>	3
<b>Total Number of Modules:</b>	12
<b>Winter Tilt Angle:</b>	35
<b>Front Edge Clearance:</b>	4
<b>Total Array Height at Tilt:</b>	11.74 ft
<b>Total Frame Length:</b>	17.00 ft
<b>Module Info/Notes:</b>	Panasonic 370
<b>Array Dimensions N/S:</b>	13.50 ft
<b>Array Dimensions E/W:</b>	17.19 ft
<b>Rail Length:</b>	162.00 in
<b>Rail Spacing:</b>	2.86 ft

### Support Specifications

<b>Pole Size:</b>	6in Pipe Sch 40
<b>Pole Length above Grade:</b>	7.87 ft
<b>Number of Poles:</b>	1
<b>Pole Spacing:</b>	0

### Foundation Specifications

<b>Foundation Type:</b>	rectangular
<b>Foundation Dimensions:</b>	48x48 in
<b>Foundation Depth (below grade):</b>	5.5 ft
<b>Foundation Volume:</b>	88.00 ft <sup>3</sup>

### Site Info

<b>Risk Category:</b>	I
<b>Exposure:</b>	C
<b>Soil Classification:</b>	sand
<b>Site Location:</b>	2222+22 Kettleman City, CA, USA
<b>Wind Speed:</b>	88 mph

**Snow Load:**

0 psf

### **Design Disclaimer**

This software should be used for preliminary designs and should not be used as a final design unless reviewed, verified and designed by a qualified structural engineer.

## AutoDesigner Input

```
{ "wind_speed_override": null, "snow_load_override": null, "direct_snow_load": false, "add_angle_brace": false, "product_type": "Beam", "designer_name": "Alcade", "designer_email": "t.bublik@iscpv.com", "designer_phone": "", "project_id": "MTSOLAR_4F1F0D5F593JE", "site_address": "2222+22 Kettleman City, CA, USA", "module_info": "Panasonic 370", "module_width": 40, "module_length": 67.75, "number_rows": 4, "number_columns": 3, "pole_mount_section": "4_40", "core_pipe_width": 65, "core_pipe_section": "2_40", "adjuster_section": "2_40", "core_beam_height": 65, "core_beam_section": "HSS3x2x1/8", "main_pipe_section": "2_12GA", "pole_spacing": "15", "tilt_angle": 35, "ground_clearance": 4, "risk_category": "I", "exposure_category": "C", "frame_duty_override": "auto", "pole_override": "auto", "soil_type": "sand", "customer_foundation_override": "48_Square", "foundation_type": "Square", "foundation_size": 48, "check_rails": false }
```

## Design Notes:

- Deflection checks are set to L/1 due to manufacturer structural design intent
- Foundation Soil Parameters used in this Autodesigned are all estimates, proper geotechnical reports are required to confirm soil profiles
- Wind speeds, snow loads and other site specific results are based on ASCE 7-16
- Steel frame design checks are based on AISC 360-16 LRFD
- Design / analysis of fixings and connections are not carried out by this module.
- Impacts of eccentrically applied, partial or pattern loading are not considered by this module.
- Foundation Design and Sizing is approximate only

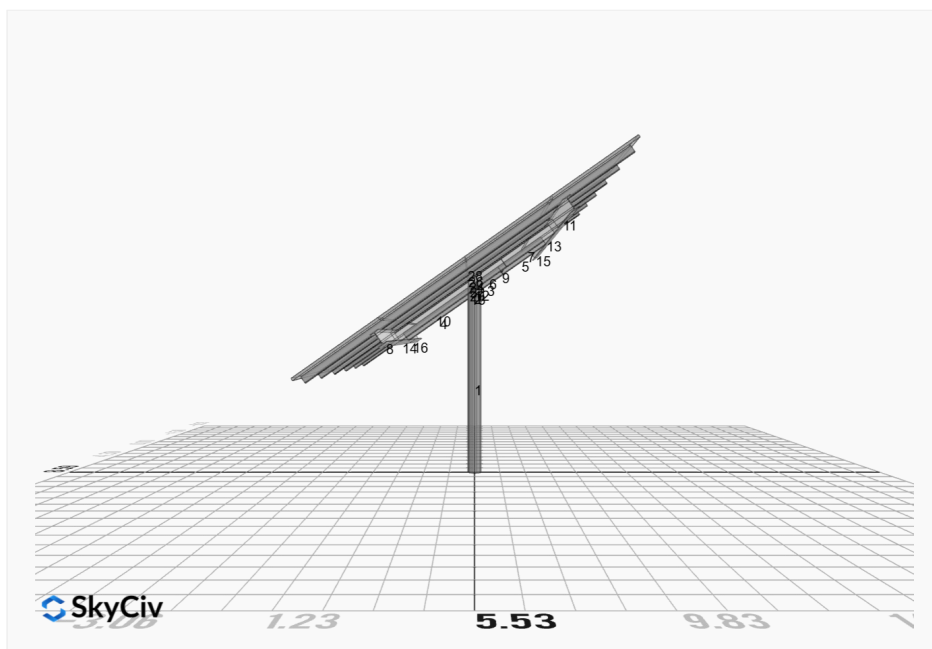
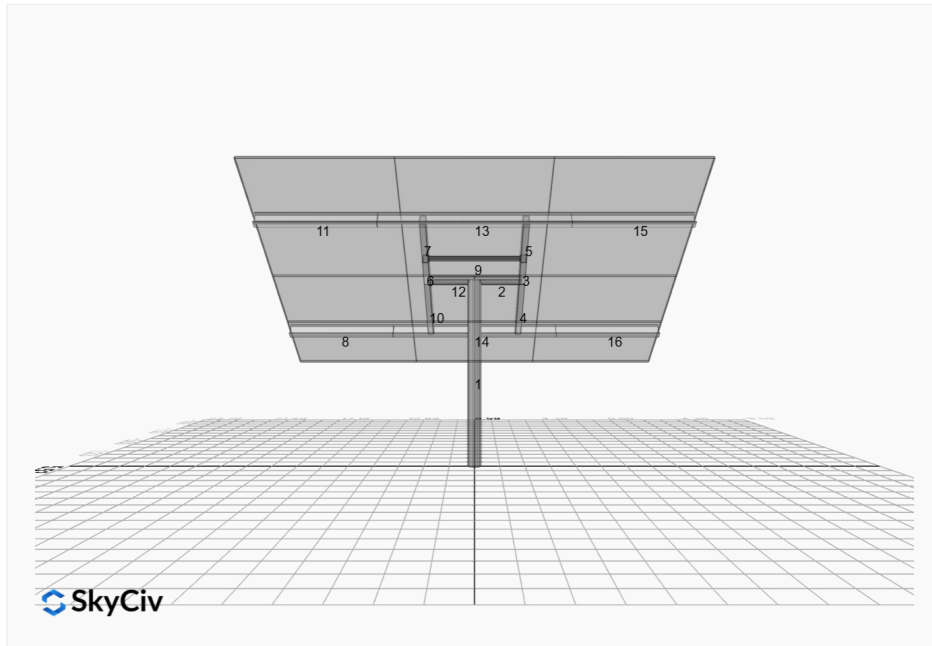

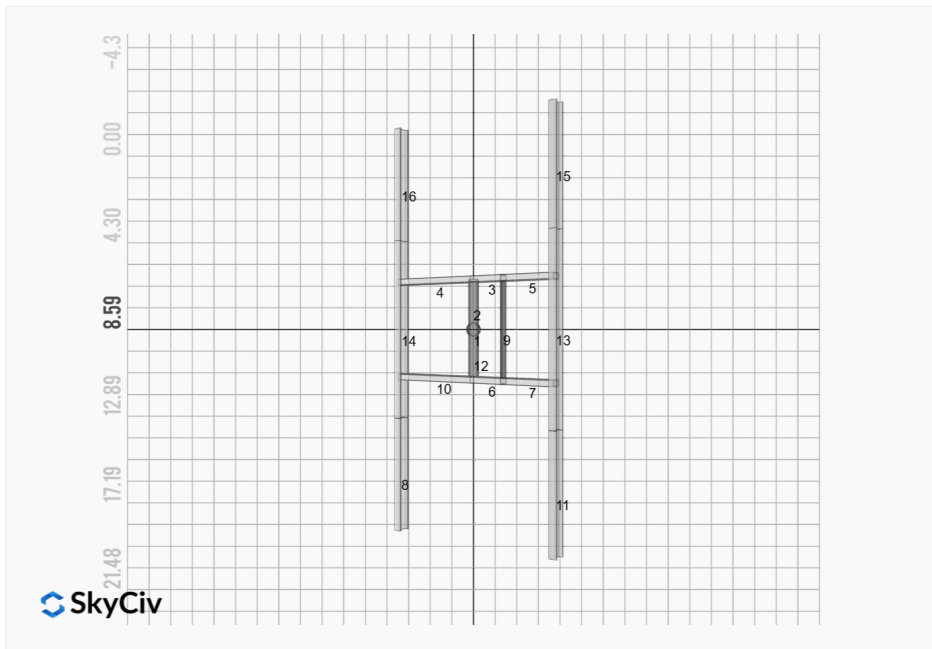

SkyCiv

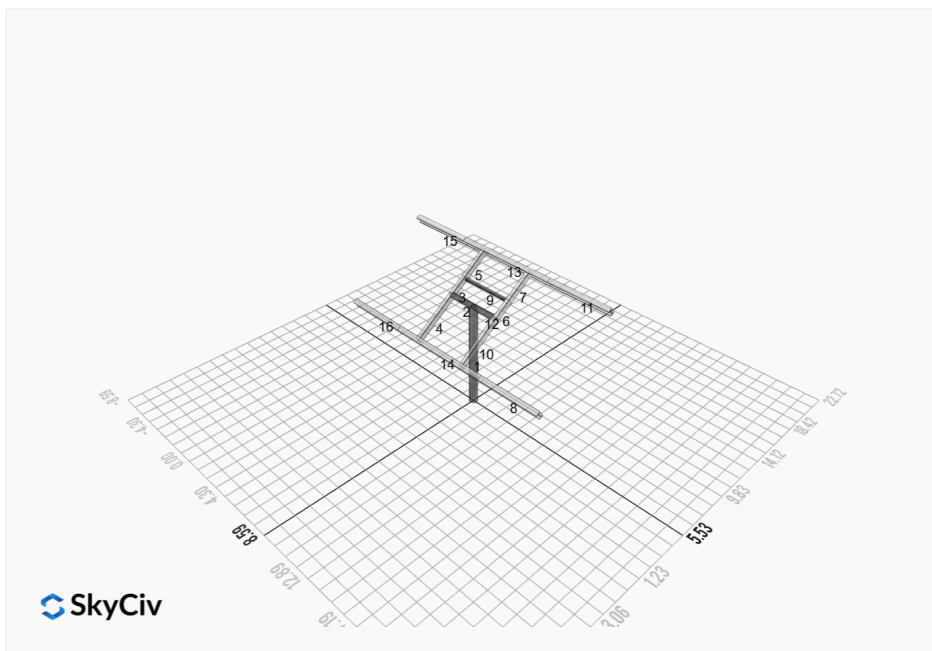

SkyCiv

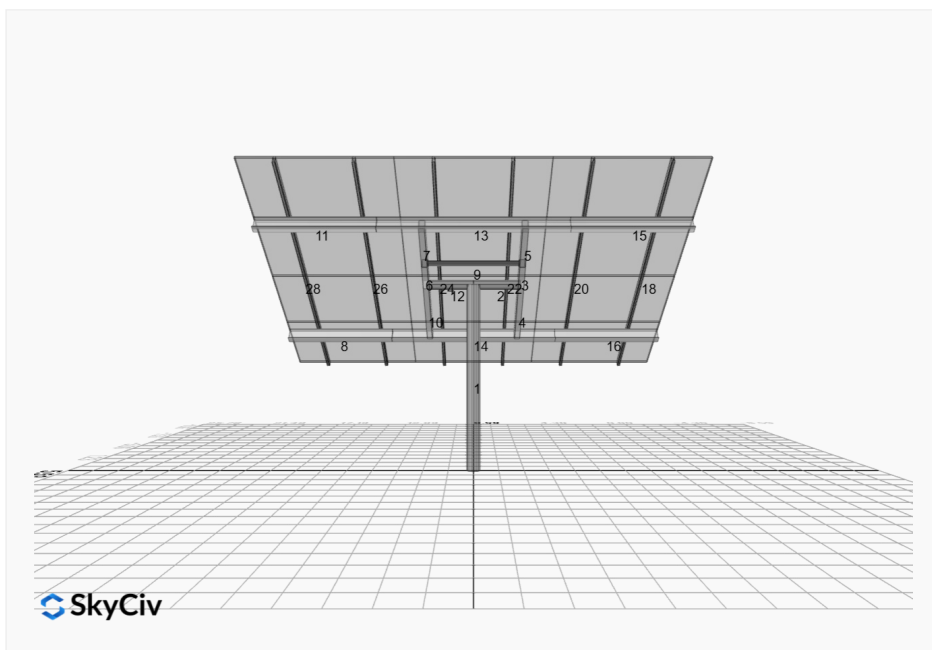

SkyCiv

# FEM Results (Envelope Worst Case)

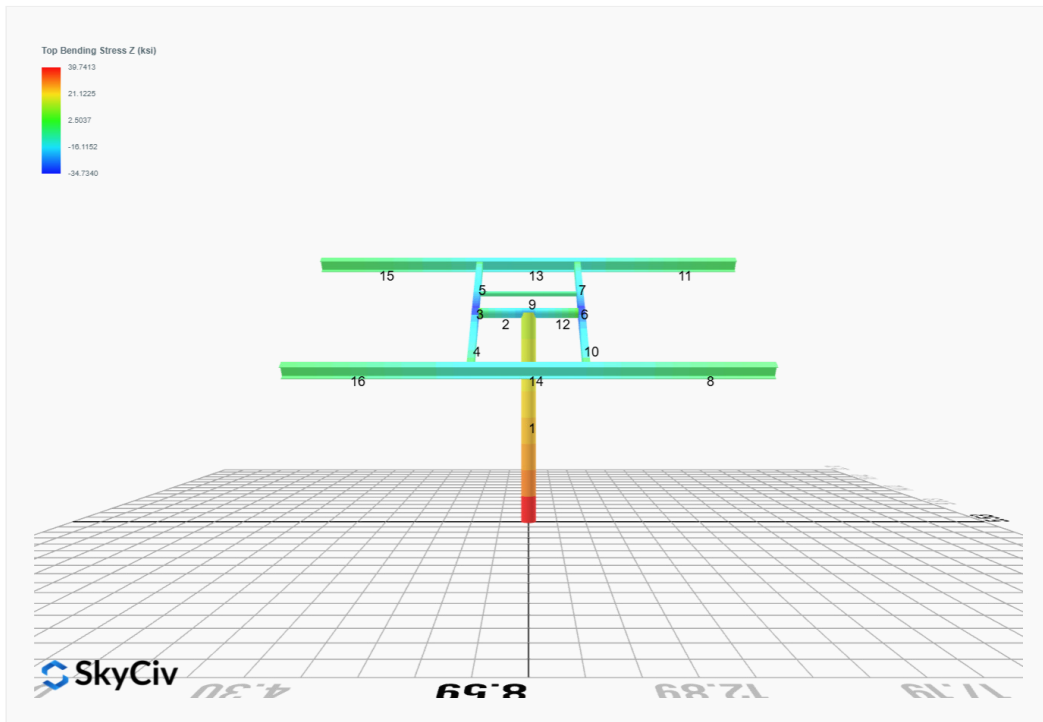
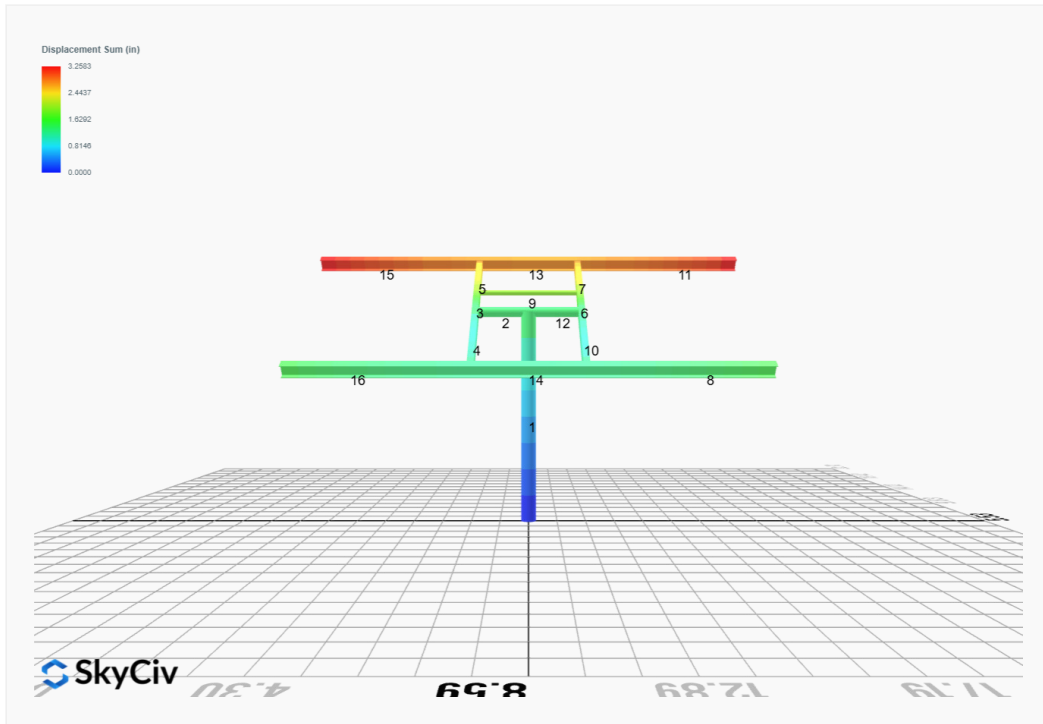





## Reaction Forces for Foundation 1 (Node ID#1), (kip, kip-ft)

### LRFD Load Combination Results

Name	Fx	Fy	Fz	Mx	My	Mz
ULS: 1. 1.4D	0.0000	2.4022	0.0000	0.0000	-0.0000	0.0313
ULS: 2. 1.2D + 1.6L + 0.5(S or Lr or R)	0.0000	2.0590	0.0000	0.0000	-0.0000	0.0259
ULS: 2. 1.2D + 1.6L + 0.5(S or Lr or R)	0.0000	2.0590	0.0000	0.0000	-0.0000	0.0259
ULS: 3. 1.2D + 1.6(S or Lr or R) + L	0.0000	2.0590	0.0000	0.0000	-0.0000	0.0259
ULS: 5. 1.2D + E + L + 0.2S	0.0000	2.0590	0.0000	0.0000	-0.0000	0.0259
ULS: 7. 0.9D + 1.0E	0.0000	1.5443	0.0000	0.0000	-0.0000	0.0184
ULS: 4. 1.2D + W + L + 0.5(S or Lr or R)_Wind downforce Case A only	-3.3716	6.8742	0.0000	0.0000	0.0000	27.6327
ULS: 4. 1.2D + W + L + 0.5(S or Lr or R)_Wind downforce Case B only	-3.3716	6.8742	0.0000	0.0000	0.0000	27.6327
ULS: 4. 1.2D + W + L + 0.5(S or Lr or R)_Wind uplift Case A only	2.8448	-2.0038	0.0000	-0.0000	-0.0000	-22.2240
ULS: 4. 1.2D + W + L + 0.5(S or Lr or R)_Wind uplift Case B only	2.3707	-1.3266	0.0000	-0.0000	-0.0000	-28.1360
ULS: 4. 1.2D + W + L + 0.5(S or Lr or R)_Wind downforce Case A only	-3.3716	6.8742	0.0000	0.0000	0.0000	27.6327
ULS: 4. 1.2D + W + L + 0.5(S or Lr or R)_Wind downforce Case B only	-3.3716	6.8742	0.0000	0.0000	0.0000	27.6327
ULS: 4. 1.2D + W + L + 0.5(S or Lr or R)_Wind uplift Case A only	2.8448	-2.0038	0.0000	-0.0000	-0.0000	-22.2240
ULS: 4. 1.2D + W + L + 0.5(S or Lr or R)_Wind uplift Case B only	2.3707	-1.3266	0.0000	-0.0000	-0.0000	-28.1360
ULS: 3. 1.2D + 1.6(S or Lr or R) + 0.5W_Wind downforce Case A only	-1.6858	4.4666	0.0000	0.0000	0.0000	13.7043
ULS: 3. 1.2D + 1.6(S or Lr or R) + 0.5W_Wind downforce Case B only	-1.6858	4.4666	0.0000	0.0000	0.0000	13.7043
ULS: 3. 1.2D + 1.6(S or Lr or R) + 0.5W_Wind uplift Case A only	1.4224	0.0276	0.0000	-0.0000	-0.0000	-11.1814
ULS: 3. 1.2D + 1.6(S or Lr or R) + 0.5W_Wind uplift Case B only	1.1853	0.3662	0.0000	-0.0000	-0.0000	-14.1569
ULS: 3. 1.2D + 1.6(S or Lr or R) + 0.5W_Wind downforce Case A only	-1.6858	4.4666	0.0000	0.0000	0.0000	13.7043
ULS: 3. 1.2D + 1.6(S or Lr or R) + 0.5W_Wind downforce Case B only	-1.6858	4.4666	0.0000	0.0000	0.0000	13.7043
ULS: 3. 1.2D + 1.6(S or Lr or R) + 0.5W_Wind uplift Case A only	1.4224	0.0276	0.0000	-0.0000	-0.0000	-11.1814
ULS: 3. 1.2D + 1.6(S or Lr or R) + 0.5W_Wind uplift Case B only	1.1853	0.3662	0.0000	-0.0000	-0.0000	-14.1569
ULS: 6. 0.9D + 1.0W_Wind downforce Case A only	-3.3716	6.3594	0.0000	0.0000	0.0000	27.5654
ULS: 6. 0.9D + 1.0W_Wind downforce Case B only	-3.3716	6.3594	0.0000	0.0000	0.0000	27.5654
ULS: 6. 0.9D + 1.0W_Wind uplift Case A only	2.8448	-2.5185	0.0000	-0.0000	-0.0000	-22.1856
ULS: 6. 0.9D + 1.0W_Wind uplift Case B only	2.3707	-1.8414	0.0000	-0.0000	-0.0000	-28.0782

### ASD Load Combination Results

Name	Fx	Fy	Fz	Mx	My	Mz
ULS: 1. D	0.0000	1.7159	0.0000	0.0000	-0.0000	0.0208
ULS: 2. D + L	0.0000	1.7159	0.0000	0.0000	-0.0000	0.0208
ULS: 3. D + (S or Lr or R)	0.0000	1.7159	0.0000	0.0000	-0.0000	0.0208
ULS: 3. D + (S or Lr or R)	0.0000	1.7159	0.0000	0.0000	-0.0000	0.0208
ULS: 4. D + 0.75L + 0.75(S or Lr or R)	0.0000	1.7159	0.0000	0.0000	-0.0000	0.0208
ULS: 4. D + 0.75L + 0.75(S or Lr or R)	0.0000	1.7159	0.0000	0.0000	-0.0000	0.0208
ULS: 5b. D + 0.7E	0.0000	1.7159	0.0000	0.0000	-0.0000	0.0208
ULS: 6b. D + 0.75L + 0.75(0.7)E + 0.75S	0.0000	1.7159	0.0000	0.0000	-0.0000	0.0208
ULS: 8. 0.6D + 0.7E	0.0000	1.0295	0.0000	0.0000	-0.0000	0.0116
ULS: 5a. D + 0.6W_Wind downforce Case A only	-2.0230	4.6050	0.0000	0.0000	0.0000	16.4411
ULS: 5a. D + 0.6W_Wind downforce Case B only	-2.0230	4.6050	0.0000	0.0000	0.0000	16.4411
ULS: 5a. D + 0.6W_Wind uplift Case A only	1.7069	-0.7218	0.0000	-0.0000	-0.0000	-13.3894
ULS: 5a. D + 0.6W_Wind uplift Case B only	1.4224	-0.3155	0.0000	-0.0000	-0.0000	-16.9475
ULS: 6a. D + 0.75L + 0.75(0.6)W + 0.75(S or Lr or R)_Wind downforce Case A only	-1.5172	3.8827	0.0000	0.0000	0.0000	12.3027
ULS: 6a. D + 0.75L + 0.75(0.6)W + 0.75(S or Lr or R)_Wind downforce Case B only	-1.5172	3.8827	0.0000	0.0000	0.0000	12.3027
ULS: 6a. D + 0.75L + 0.75(0.6)W + 0.75(S or Lr or R)_Wind uplift Case A only	1.2802	-0.1124	0.0000	-0.0000	-0.0000	-10.0592
ULS: 6a. D + 0.75L + 0.75(0.6)W + 0.75(S or Lr or R)_Wind uplift Case B only	1.0668	0.1923	0.0000	-0.0000	-0.0000	-12.7330

Name	Fx	Fy	Fz	Mx	My	Mz
ULS: 6a. D + 0.75L + 0.75(0.6)W + 0.75(S or Lr or R)_Wind downforce Case A only	-1.5172	3.8827	0.0000	0.0000	0.0000	12.3027
ULS: 6a. D + 0.75L + 0.75(0.6)W + 0.75(S or Lr or R)_Wind downforce Case B only	-1.5172	3.8827	0.0000	0.0000	0.0000	12.3027
ULS: 6a. D + 0.75L + 0.75(0.6)W + 0.75(S or Lr or R)_Wind uplift Case A only	1.2802	-0.1124	0.0000	-0.0000	-0.0000	-10.0592
ULS: 6a. D + 0.75L + 0.75(0.6)W + 0.75(S or Lr or R)_Wind uplift Case B only	1.0668	0.1923	0.0000	-0.0000	-0.0000	-12.7330
ULS: 7. 0.6D + 0.6W_Wind downforce Case A only	-2.0230	3.9186	0.0000	0.0000	0.0000	16.3851
ULS: 7. 0.6D + 0.6W_Wind downforce Case B only	-2.0230	3.9186	0.0000	0.0000	0.0000	16.3851
ULS: 7. 0.6D + 0.6W_Wind uplift Case A only	1.7069	-1.4082	0.0000	-0.0000	-0.0000	-13.3615
ULS: 7. 0.6D + 0.6W_Wind uplift Case B only	1.4224	-1.0019	0.0000	-0.0000	-0.0000	-16.9040

### Worst Case Reactions (LRFD)

Note: Downforce / downwind wind load cases are assumed to govern.

Result	Value (kip, kip-ft)
Axial	6.8742
Shear X	-3.3716
Shear Z	0.0000
Moment X	-0.0000
Moment Y (Twist)	0.0000
Moment Z	28.1360

### Worst Case Reactions (ASD)

Note: Downforce / downwind wind load cases are assumed to govern.

Result	Value (kip, kip-ft)
Axial	4.6050
Shear X	-2.0230
Shear Z	0.0000
Moment X	-0.0000
Moment Y (Twist)	0.0000
Moment Z	16.9475

## Project Details

Design Code: AISC 360-16 LRFD  
 Provision: LRFD  
 Country: United States  
 User Name: sales@mtsolar.us  
 Unit System: imperial



## Design Input Information

Design Factors			
$\Phi_t$	$\Phi_c$	$\Phi_b$	$\Phi_v$
0.9	0.9	0.9	0.9

Design Materials			
ID	E (ksi)	$F_y$ (ksi)	$F_u$ (ksi)
1	29000	50	65
2	29000	46	62
4	29000	50	62

Section Dimensions							

ID	Name	d (in)	$t_w$ (in)				
1	2in Pipe Sch 40	2.38	0.15				
4	4in Pipe Sch 40	4.50	0.24				
7	6in Pipe Sch 40	6.63	0.28				

--	--	--	--	--	--	--	--

ID	Name	d (in)	b (in)	$t_w$ (in)	$t_b$ (in)	r (in)	
15	HSS5x3x1/8	5.00	3.00	0.12	0.12	0.12	

--	--	--	--	--	--	--	--

ID	Name	d (in)	$t_w$ (in)	$b_t$ (in)	$b_b$ (in)	$t_t$ (in)	$t_b$ (in)	r (in)
18	W6x9	5.90	0.17	3.94	3.94	0.21	0.21	0.25

### Section Properties



3	79.65	74.89	10.99	6.26	29.14	16.61
4	79.65	72.84	10.99	6.26	29.14	16.61
5	79.65	74.30	10.99	6.26	29.14	16.61
6	79.65	74.89	10.99	6.26	29.14	16.61
7	79.65	74.30	10.99	6.26	29.14	16.61
8	120.60	34.69	23.36	6.45	30.09	45.74
9	44.49	40.02	2.63	2.63	13.35	13.35
10	79.65	72.84	10.99	6.26	29.14	16.61
11	120.60	34.69	23.36	6.45	30.09	45.74
12	131.41	130.46	14.87	14.87	39.42	39.42
13	120.60	84.03	18.15	6.45	30.09	45.74
14	120.60	84.03	17.82	6.45	30.09	45.74
15	120.60	34.69	23.36	6.45	30.09	45.74
16	120.60	34.69	23.36	6.45	30.09	45.74

## Design Ratio

Member ID	P	M <sub>z</sub>	M <sub>y</sub>	V <sub>y</sub>	V <sub>z</sub>	(P,M <sub>z</sub> ,M <sub>y</sub> )	Worst LC	KL/r	δ	Status
1	0.031	0.723	0.000	0.049	0.000	0.726	#16	0.137	Not Required	Pass
2	0.001	0.401	0.228	0.085	0.043	0.630	#13	0.034	Not Required	Pass
3	0.004	0.635	0.026	0.064	0.002	0.660	#13	0.044	Not Required	Pass
4	0.004	0.618	0.079	0.062	0.013	0.664	#13	0.078	Not Required	Pass
5	0.004	0.394	0.083	0.064	0.017	0.413	#13	0.073	Not Required	Pass
6	0.004	0.635	0.026	0.064	0.002	0.660	#13	0.044	Not Required	Pass
7	0.004	0.394	0.083	0.064	0.017	0.413	#13	0.073	Not Required	Pass
8	0.000	0.102	0.059	0.033	0.003	0.152	#13	Not Required	Not Required	Pass
9	0.006	0.068	0.051	0.001	0.000	0.122	#13	0.198	Not Required	Pass
10	0.004	0.618	0.079	0.062	0.013	0.664	#13	0.078	Not Required	Pass
11	0.000	0.105	0.059	0.034	0.003	0.155	#13	Not Required	Not Required	Pass
12	0.001	0.401	0.228	0.085	0.043	0.630	#13	0.034	Not Required	Pass
13	0.002	0.259	0.110	0.047	0.005	0.346	#13	0.177	Not Required	Pass
14	0.003	0.258	0.110	0.046	0.005	0.340	#13	0.177	Not Required	Pass
15	0.000	0.105	0.059	0.034	0.003	0.155	#13	Not Required	Not Required	Pass
16	0.000	0.102	0.059	0.033	0.003	0.152	#13	Not Required	Not Required	Pass

## Definitions

$\Phi_t$	Safety factor for tensile
$\Phi_c$	Safety factor for compression
$\Phi_b$	Safety factor for flexure
$\Phi_v$	Safety factor for shear
E	Modulus of elasticity
F <sub>y</sub>	Specified minimum yield stress
F <sub>u</sub>	Specified minimum tensile strength
A	Cross-sectional area
J	Torsional constant
I <sub>yp</sub>	Moment of inertia about the Y axes
I <sub>zp</sub>	Moment of inertia about the Z axes
I <sub>w</sub>	Warping constant
S <sub>yp</sub>	Plastic section modulus about the Y axis
S <sub>zp</sub>	Plastic section modulus about the Z axis
KL	Effective length
C <sub>b</sub>	Buckling modification factor (from all load combinations)
L <sub>b</sub>	Length between braced points
LST	Limited slenderness for tension
LSC	Limited slenderness for compression

LD	Limited deflection
$P_n$	Nominal axial strength (tension/compression)
$M_n$	Nominal flexural strength (about Z/Y axis)
$V_n$	Nominal shear strength (along Z/Y axis)
P	Design ratio in case of axial force
$M_z$	Design ratio in case of bending about Z axis
$M_y$	Design ratio in case of bending about Y axis
$V_y$	Design ratio in case of shear along Y axis
$V_z$	Design ratio in case of shear along Z axis
$(P, M_z, M_y)$	Design ratio in case of axial force and bending action
$KL/r$	Design ratio in case of section slenderness
$\delta$	Design ratio in case of member deflection
OK	Capacity is provided
NG	Capacity is not provided

IBC 2018 Pile Design



Input	Description
Region	American Standard
Concrete design code	American Concrete Institute (ACI 318:2019)

Cross-section

Input	Description	Value
Shape	Cross-sectional shape	Square
b	Section width	48 in
D	Section depth	48 in

Material Properties

Input	Description	Value
$f'_{ck}$	Concrete compressive strength	2.5 ksi
$f_{yk}$	Yield strength of steel	60 ksi
$d_b$	Rebar diameter	#5 (0.625) in
cover	Concrete cover	3 in

Soil Parameters (IBC 1806)

Input	Description	Value
Soil type	Sand, silty sand, clayey sand, silty gravel & clayey gravel	
$q_a$	Allowable bearing pressure	2000 psf
R	Allowable lateral pressure	150 psf/ft

Loading

Load	ASD	LRFD
P	4.605 kip	6.874 kip
V <sub>x</sub>	-2.023 kip	-3.372 kip
V <sub>z</sub>	0 kip	0 kip
M <sub>x</sub>	0 kip-ft	0 kip-ft
M <sub>z</sub>	16.95 kip-ft	28.14 kip-ft

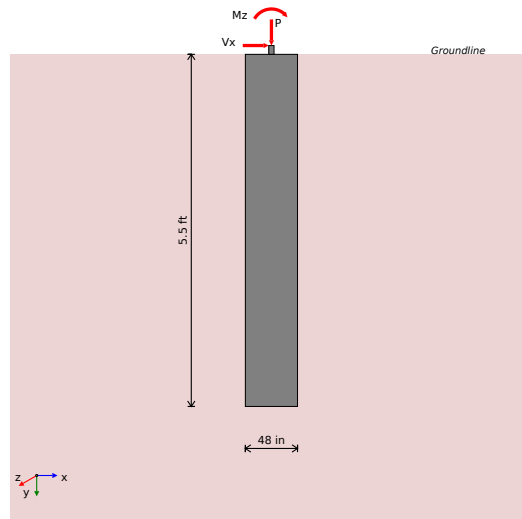

Required depth to resist lateral loads (ASD)

Allowable lateral pressure

$$R = 150 \text{ psf/ft}$$

Point of application of lateral load:

$$H = h_1 + h_2 + h_e = 0 + 0 + 0 = 0 \text{ ft}$$

Considering x-direction:

Lateral force per section length

$$H_o = \frac{V_x}{1.57 \times D} = \frac{-2.023}{1.57 \times 48} = -0.322 \frac{\text{kip}}{\text{ft}}$$

Moment per section length

$$M_o = \frac{M_z + (V_z \times H)}{1.57 \times D} = \frac{16.95 + (-2.023 \times 0)}{1.57 \times 48} = 2.699 \frac{\text{kip} \cdot \text{ft}}{\text{ft}}$$

Required depth of embedment in earth:

$$L_e^3 - \left(9 \times \frac{H_o \times L_z}{R}\right) - \left(12 \times \frac{M_o}{R}\right) = 0$$

Solving the cubic equation:

$$L_{e,z} = 4.938 \text{ ft}$$

Considering z-direction:

Since there are no loads applied in this direction, the required effective length:  $L_{e,z} = 0 \text{ ft}$ .

**Minimum embedded depth**

Depth of pile required

$$L_{e,req} = \text{MAX}[L_{e,x}, L_{e,z}] = \text{MAX}[4.938, 0] = 4.938 \text{ ft}$$

Actual embedded length

$$L_e = L - h_2 - h_e = 5.5 - 0 - 0 = 5.5 \text{ ft}$$

Utilisation

$$\text{Ratio} = \frac{L_{e,req}}{L_e} = \frac{4.938}{5.5} = 0.898$$

UTILITY: 0.90

## REFERENCES

## CALCULATIONS

## RESULTS

### End-bearing Capacity (ASD)

Allowable bearing pressure  
Unit weight of concrete

$q_a = 2000 \text{ psf}$   
 $w_c = 0.15 \text{ kip/ft}^3$

Cross-sectional area:

$$A = b \times D = 48 \times 48 = 16 \text{ ft}^2$$

End-bearing pressure:

$$q = \frac{P}{A} = \frac{4.605}{16} = 287.8 \text{ psf}$$

Utilisation

$$\text{Ratio} = \frac{q}{q_a} = \frac{287.8}{2000} = 0.144$$

UTILITY: 0.14

### Lateral Soil Pressure (ASD)

Allowable lateral pressure

$R = 150 \text{ psf/ft}$

Length to least lateral dimension ratio:

$$\frac{L}{\text{MIN}[b, D]} = \frac{5.5}{\text{MIN}[4, 4]} = 1.375$$

L/D ratio  $\leq 10$ . This pile is classified as a short pile.

Considering x-direction:

Distance from resting surface to pivot point:

$$a = \frac{(4 \times M_o \times L_e) + (3 \times H_o \times L_e^2)}{(6 \times M_o) + (4 \times H_o \times L_e)}$$

$$a = \frac{(4 \times 2.699 \times 5.5) + (3 \times 0.322 \times 5.5^2)}{(6 \times 2.699) + (4 \times 0.322 \times 5.5)} = 3.806 \text{ ft}$$

Earth pressure against the pile at a distance a/2 from the resting surface:

$$p = \frac{0.75 \times [(4 \times M_o) + (3 \times H_o \times L_e)]^2}{L_e^2 \times [(3 \times M_o) + (2 \times H_o \times L_e)]}$$

$$p = \frac{0.75 \times [(4 \times 2.699) + (3 \times -0.322 \times 5.5)]^2}{5.5^2 \times [(3 \times 2.699) + (2 \times -0.322 \times 5.5)]} = 0.164 \frac{\text{kip}}{\text{ft}^2}$$

Allowable lateral soil pressure at a depth of a/2:

$$p_a = R \times \frac{a}{2} = 0.15 \times \frac{3.806}{2} = 0.285 \frac{\text{kip}}{\text{ft}^2}$$

Utilisation - pressure at a depth of a/2

$$\text{Ratio} = \frac{p}{p_a} = \frac{0.164}{0.285} = 0.573$$

UTILITY: 0.57

Earth pressure against the pile at distance  $L_e$ :

$$s = \frac{6 \times [(2 \times M_o) + (H_o \times L_e)]}{L_e^2} = \frac{6 \times [(2 \times 2.699) + (-0.322 \times 5.5)]}{5.5^2} = 0.719 \frac{\text{kip}}{\text{ft}^2}$$

Allowable lateral soil pressure at a depth of  $L_e$ :

$$p_s = R \times L_e = 0.15 \times 5.5 = 0.825 \frac{\text{kip}}{\text{ft}^2}$$

Utilisation - pressure at a depth of  $L_e$

$$\text{Ratio} = \frac{s}{p_s} = \frac{0.719}{0.825} = 0.872$$

UTILITY: 0.87

Considering z-direction:

Since no loads are applied in this direction, lateral soil pressure check is not required.

## REFERENCES

## CALCULATIONS

## RESULTS

### Shear force and bending moment (LRFD)

Considering x-direction:

Lateral force per section length

$$H_o = \frac{V_x}{1.57 \times D} = \frac{-3.372}{1.57 \times 48} = -0.537 \frac{\text{kip}}{\text{ft}}$$

Moment per section length

$$M_o = \frac{M_z + (V_x \times H)}{1.57 \times D} = \frac{28.14 + (-3.372 \times 0)}{1.57 \times 48} = 4.48 \frac{\text{kip-ft}}{\text{ft}}$$

Distance from resting surface to pivot point:

$$a = \frac{(4 \times M_o \times L_e) + (3 \times H_o \times L_e^2)}{(6 \times M_o) + (4 \times H_o \times L_e)}$$

$$a = \frac{(4 \times 4.48 \times 5.5) + (3 \times 0.537 \times 5.5^2)}{(6 \times 4.48) + (4 \times 0.537 \times 5.5)} = 3.807 \text{ ft}$$

Max shear force located at depth a:

$$E = \frac{M_o}{H_o} = \frac{4.48}{-0.537} = 8.345 \text{ ft}$$

$$V_{max,x} = (H_o \times D) \times [1 - 3 \times \left(\frac{4 \times E}{L_e} + 3\right) \times \left(\frac{a}{L_e}\right)^2] + [4 \times \left(\frac{3 \times E}{L_e} + 2\right) \times \left(\frac{a}{L_e}\right)^3]$$

$$V_{max,x} = (-0.537 \times 48) \times [1 - 3 \times \left(\frac{4 \times 8.345}{5.5} + 3\right) \times \left(\frac{3.807}{5.5}\right)^2] + [4 \times \left(\frac{3 \times 8.345}{5.5} + 2\right) \times \left(\frac{3.807}{5.5}\right)^3]$$

$$V_{max,x} = 7.182 \text{ kip}$$

Max bending moment located at a depth of a/2:

$$M_{max,x} = (H_o \times D \times L_e) \times \left[\left(\frac{E}{L_e} + \frac{a}{2 \times L_e}\right) - \left[\left(\frac{4 \times E}{L_e} + 3\right) \times \left(\frac{a}{2 \times L_e}\right)^3\right] + \left[\left(\frac{3 \times E}{L_e} + 2\right) \times \left(\frac{a}{2 \times L_e}\right)^4\right]\right]$$

$$M_{max,x} = (-0.537 \times 48 \times 5.5) \times \left[\left(\frac{8.345}{5.5} + \frac{3.807}{2 \times 5.5}\right) - \left[\left(\frac{4 \times 8.345}{5.5} + 3\right) \times \left(\frac{3.807}{2 \times 5.5}\right)^3\right] + \left[\left(\frac{3 \times 8.345}{5.5} + 2\right) \times \left(\frac{3.807}{2 \times 5.5}\right)^4\right]\right]$$

$$M_{max,x} = 18.68 \text{ kip-ft}$$

Considering z-direction:

There are no loads applied in this direction.

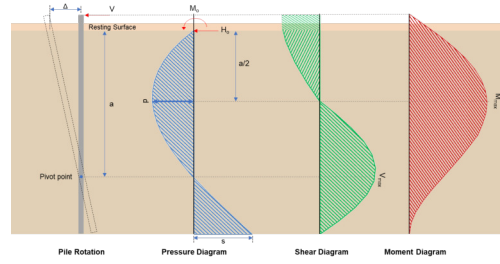

## Minimum Reinforcement Check (LRFD)

Gross area of concrete:

$$A_g = b \times D = 48 \times 48 = 2304 \text{ in}^2$$

### Main Reinforcement

22.4.2.2 Required reinforcement:

$$A_{st,req} = \frac{P - (0.85 \times f'_{ck} \times A_g)}{f_{yk} - (0.85 \times f'_{ck})} = \frac{6.874 - (0.85 \times 2.5 \times 2304)}{60 - (0.85 \times 2.5)} = -84.48 \text{ in}^2$$

10.6.1.1 Maximum reinforcement:

$$A_{st,max} = 0.08 \times A_g = 0.08 \times 2304 = 184.3 \text{ in}^2$$

7.6.1.1 Minimum reinforcement:

$$A_{st,min} = 0.0018 \times A_g = 0.0018 \times 2304 = 4.147 \text{ in}^2$$

Governing minimum reinforcement area:

$$(0.0018 \times A_g) \leq A_{st,req} \leq (0.08 \times A_g)$$

$$A_{min} = 4.147 \text{ in}^2$$

Minimum number of reinforcements:

$$A_{bar} = 0.307 \text{ in}^2$$

$$n_{min} = \frac{A_{min}}{A_{bar}} = \frac{4.147}{0.307} = 14$$

25.2.3 Minimum spacing:

$$s_{rebar} = \text{MAX}[1.5, 1.5 \times d_b] = \text{MAX}[1.5, (1.5 \times 0.625)] = 1.5 \text{ in}$$

Use:  $n = 16$  pcs at 1.5 in minimum spacing

Total reinforcement area:

$$A_{st} = 16 \times 0.307 = 4.909 \text{ in}^2$$

### Shear Reinforcement

25.7.2.2 For main reinforcement  $\leq 1.41$  in: Use #3(0.375 in)

Maximum spacing of shear Reinforcements:

$$s = \text{MIN}[16 \times d_b, 48 \times d_{b,ires}, \text{MIN}(b, D)] = \text{MIN}[(16 \times 0.625), (48 \times 0.375), \text{MIN}(48, 48)] = 10 \text{ in}$$

#### Detailing Summary

Detailing Summary	
Main reinforcement	#5 (0.625 in) - 16pcs at 1.5 in min. spacing
Shear reinforcement	#3 (0.375 in) at 10 in max. spacing

## Axial Compression Strength (LRFD)

22.4.2.2 Allowable axial compressive strength:

$$\phi P_N = \phi \times 0.8 \times [(0.85 \times f'_{ck} \times [A_g - A_{st}]) + (f_{yk} \times A_{st})]$$

$$\phi P_N = 0.65 \times 0.8 \times [(0.85 \times 2.5 \times [2304 - 4.909]) + (60 \times 4.909)] = 2694 \text{ kip}$$

Utilisation

$$\text{Ratio} = \frac{P}{\phi P_N} = \frac{6.874}{2694} = 0.003$$

### Shear Strength LRFD

Effective shear width	$b_w = 48$ in
Effective shear depth	$d = 44.31$ in
Shear reinforcement area	$A_v = 0.221$ in <sup>2</sup>
Shear reinforcement spacing	$s = 10$ in
Concrete type factor (Normal concrete)	$\lambda = 1$
Strength reduction factor for shear	$\phi = 0.75$
Maximum shear in the x-direction	$V_{max,x} = 7.182$ kip
Maximum shear in the z-direction	$V_{max,z} = 0$ kip

22.5.5.1.1 Max shear strength of concrete:

$$V_{c,max} = 5 \times \lambda \times \sqrt{f'_{ck}} \times b_w \times d = 5 \times 1 \times \sqrt{2.5} \times 48 \times 44.31 = 531.8 \text{ kip}$$

Table 22.5.5.1 Shear strength of concrete:

$$V_{c,a} = \left( 2 \times \lambda \times \sqrt{f'_{ck}} + \text{MIN} \left[ \frac{P}{6 \times A_g}, (0.05 \times f'_{ck}) \right] \right) \times (b_w \times d)$$

$$V_{c,a} = \left( 2 \times 1 \times \sqrt{2.5} + \text{MIN} \left[ \frac{6.874}{6 \times 2304}, (0.05 \times 2.5) \right] \right) \times (48 \times 44.31) = 213.8 \text{ kip}$$

Governing shear strength of concrete:

$$V_c = \text{MIN}[V_{c,max}, V_{c,a}] = \text{MIN}[531.8, 213.8] = 213.8 \text{ kip}$$

22.5.1.2 Shear strength of steel (a):

$$V_{s,a} = 8 \times \sqrt{f'_{ck}} \times b_w \times d = 8 \times \sqrt{2.5} \times 48 \times 44.31 = 850.8 \text{ kip}$$

22.5.8.5.3 Shear strength of steel (b):

$$V_{s,b} = \frac{A_v \times f_{yk} \times d}{s} = \frac{0.221 \times 60 \times 44.31}{10} = 58.73 \text{ kip}$$

Governing shear strength of steel:

$$V_s = \text{MIN}[V_{s,a}, V_{s,b}] = \text{MIN}[850.8, 58.73] = 58.73 \text{ kip}$$

22.5.1.1 Allowable shear strength:

$$\phi V_n = \phi \times (V_c + V_s) = 0.75 \times (213.8 + 58.73) = 204.4 \text{ kip}$$

$$V_{max} = \text{MAX}[7.182, 0] = 7.182 \text{ kip}$$

Utilisation

$$\text{Ratio} = \frac{V_{max}}{\phi V_n} = \frac{7.182}{204.4} = 0.035$$

### Flexural Strength (LRFD)

Concrete type factor (Normal concrete)	$\lambda = 1$
Strength reduction factor for flexure	$\phi = 0.65$
Modulus of steel reinforcement	$E_s = 200e3$ ksi
Maximum concrete strain	$\epsilon_c = 0.0030$
Yield strain of steel $f_y/E_s$	$\epsilon_y = 0.0003$
Section width	$b = 48$ in
Distance to the compression rebar	$d_c = 3.688$ in
Distance to the tension rebar	$d = 44.31$ in
Total bar area	$A_s = 4.909$ in <sup>2</sup>
Maximum applied axial load	$P = 6.874$ kip
Maximum moment in the x-direction	$M_{max,x} = 18.68$ kip-ft
Maximum moment in the z-direction	$M_{max,z} = 0$ kip-ft

Compressive force due to concrete:

$$\beta_1 = 0.85$$

$$C_{rc} = 0.85 \times \beta_1 \times f'_c \times b \times c$$

Compressive force due to bars in compression:

$$C_{rs} = f_1 \times A_{sc}$$

$$\epsilon_1 = (c - d_s) \times \frac{\epsilon_c}{c}$$

$$f_1 = E_s \times \varepsilon_1 \quad (\varepsilon_1 < \varepsilon_{sy}), f_1 = f_y \quad (\varepsilon_1 \geq \varepsilon_{sy})$$

Tensile force due to bars in tension:

$$T_{rs} = f_2 \times A_{st}$$

$$\varepsilon_2 = (d - c) \times \frac{\varepsilon_{cu}}{c}$$

$$f_2 = E_s \times \varepsilon_2 \quad (\varepsilon_2 < \varepsilon_{sy}), f_2 = \phi_s \times f_y \quad (\varepsilon_2 \geq \varepsilon_{sy})$$

### Interaction Diagram Summary

Point	Case	M <sub>r</sub>	P <sub>r</sub>
P1	Pure Tension	0	-265.1
P2	Pure Bending	498.4	0
P3	Balanced Failure	1303	2402
P4	Decompression	1077	2629
P5	Compression Limit	982	2694
P6	Pure Compression	0	2694

### Uniaxial Bending Check

$$M_f = \text{MAX}[18.68, 0] = 18.68 \text{ kip-ft}$$

### Interaction Diagram

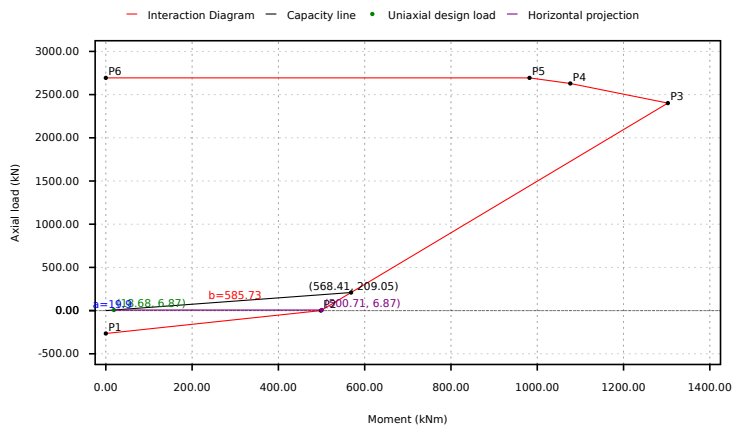

Segment	Signed Distance
P1 - P2	231.3
P2 - P3	457.1
P3 - P4	2600
P4 - P5	2761
P5 - P6	2687
Status	PASS: Point lies inside the curve

Utilisation

$$\text{Ratio} = \frac{a}{a+b} = \frac{19.9}{19.9+585.7} = 0.033$$

UTILITY: 0.03

### REFERENCES

### CALCULATIONS

### RESULTS

### Results Summary

Result Name	Results
<b>PILE DETAILS</b>	
Length of the pile	5.50 ft
Dimensions	48 x 48 in
Main bar reinforcement	#5-16pcs at 1.5 in min.
Shear reinforcement	#3 at 10 in max.
<b>UTILISATIONS</b>	
Required depth	0.90
End-bearing capacity	0.14
P <sub>a</sub>	0.57
P <sub>s</sub>	0.87
Axial compression strength	0.00
Shear strength	0.04
Uniaxial bending strength	0.03

