

**Project Name:** Garvey **Date:** Thu Apr 10 2025  
**Location:** 1578 Co Rd 55, Leadville, CO 80461, USA **Number of Modules:** 12  
**Unique ID:** 1P-0-6TOP-SD-57-L-4Hx3W-1EA6 **Number of Poles:** 1  
**Dealer:** \_\_\_\_\_ **Date Sold:** \_\_\_\_\_

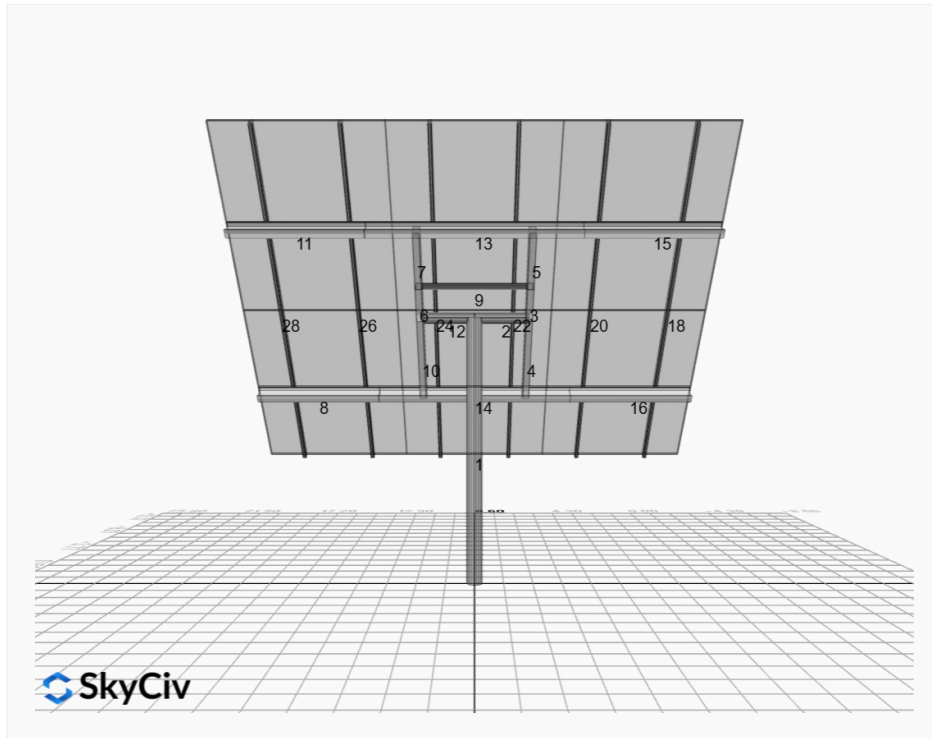

<b>Array Dimensions N/S</b>	15.03 ft
<b>Array Dimensions E/W</b>	17.20 ft
<b>Winter Tilt Angle</b>	50
<b>Front Edge Clearance</b>	4 ft

### MT Solar Bill of Materials (1P-0-6TOP-SD-57-L-4Hx3W-1EA6)

Part	Short Description	BOM Qty
MTS-PC-6	6IN Pole Cap Assembly	1
MTS-HF-SD	H-Frame Assembly-SD	1
MTS-SD-Wing-57	57IN SD Wing	4
MTS-CLAMP-HOOK-4PK	Hook Clamp	3

### Rail Bill of Materials

Part	Qty
Rails (180in)	6
Rail Attachment	12
Module Mid Clamp	18
Module End Clamp	12
Ground Lug	3

## Site Details:



**Site Address:** 1578 Co Rd 55, Leadville, CO 80461, USA

### Array Specification

<b>Duty Classification:</b>	SD
<b>Module Width:</b>	44.60 in
<b>Module Length:</b>	67.80in
<b>Number of Rows:</b>	4
<b>Number of Columns:</b>	3
<b>Total Number of Modules:</b>	12
<b>Winter Tilt Angle:</b>	50
<b>Front Edge Clearance:</b>	4
<b>Total Array Height at Tilt:</b>	15.52 ft
<b>Total Frame Length:</b>	17.00 ft
<b>Module Info/Notes:</b>	Q.TRON 425W
<b>Array Dimensions N/S:</b>	15.03 ft
<b>Array Dimensions E/W:</b>	17.20 ft
<b>Rail Length:</b>	180.40 in
<b>Rail Spacing:</b>	2.87 ft

### Support Specifications

<b>Pole Size:</b>	6in Pipe Sch 40
<b>Pole Length above Grade:</b>	9.76 ft
<b>Number of Poles:</b>	1
<b>Pole Spacing:</b>	0

### Foundation Specifications

<b>Foundation Type:</b>	Square
<b>Foundation Dimensions:</b>	48 x 48 in
<b>Foundation Depth (below grade):</b>	Pile 1: 5.50 ft
<b>Foundation Volume:</b>	3.259 y <sup>3</sup>

### Site Info

<b>Risk Category:</b>	II
<b>Exposure:</b>	C
<b>Soil Classification:</b>	sand
<b>Site Location:</b>	1578 Co Rd 55, Leadville, CO 80461, USA
<b>Wind Speed:</b>	105 mph
<b>Snow Load:</b>	72 psf

### **Design Disclaimer**

This software should be used for preliminary designs and should not be used as a final design unless reviewed, verified and designed by a qualified structural engineer.

## AutoDesigner Input

```
{ "product_type": "Beam", "designer_name": "", "designer_email": "tannerl@coloradosolarenergy.net", "designer_phone": "", "project_id": "Garvey", "site_address": "1578 Co Rd 55, Leadville, CO 80461, USA", "module_info": "Q.TRON 425W", "module_width": 44.6, "module_length": 67.8, "number_rows": 4, "number_columns": 3, "pole_mount_section": "4_40", "core_pipe_width": 65, "core_pipe_section": "2_40", "adjuster_section": "2_40", "core_beam_height": 65, "core_beam_section": "HSS3x2x1/8", "main_pipe_section": "2_12GA", "pole_spacing": 15, "number_of_poles": 1, "tilt_angle": 50, "ground_clearance": 4, "risk_category": "II", "exposure_category": "C", "frame_duty_override": "auto", "pole_override": "auto", "soil_type": "sand", "customer_foundation_override": "48_Square", "foundation_type": "Square", "foundation_size": 48, "check_rails": true, "wind_speed_override": 105, "snow_load_override": 72, "direct_snow_load": false, "add_angle_brace": false }
```

## Design Notes:

- AISC Deflection checks are set to L/1 due to structure design intent
- Foundation Soil Parameters used in this Autodesign are all estimates, proper geotechnical reports are required to confirm soil profiles
- Wind speeds, snow loads and other site specific results are based on ASCE 7 2016
- Steel frame design checks are based on AISC 360 2016 (LRFD)

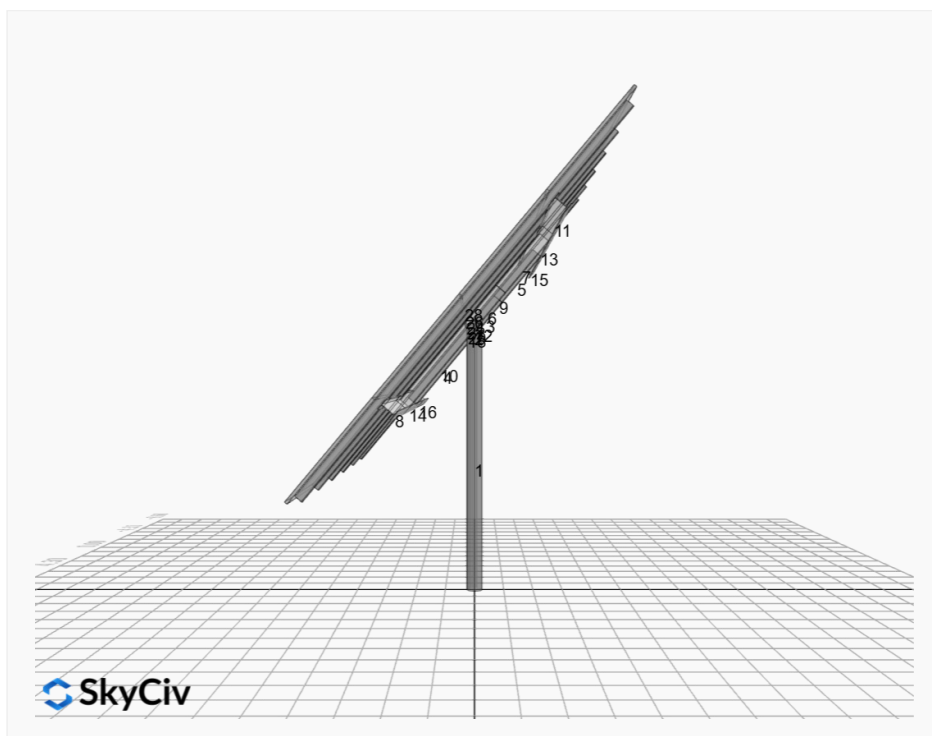
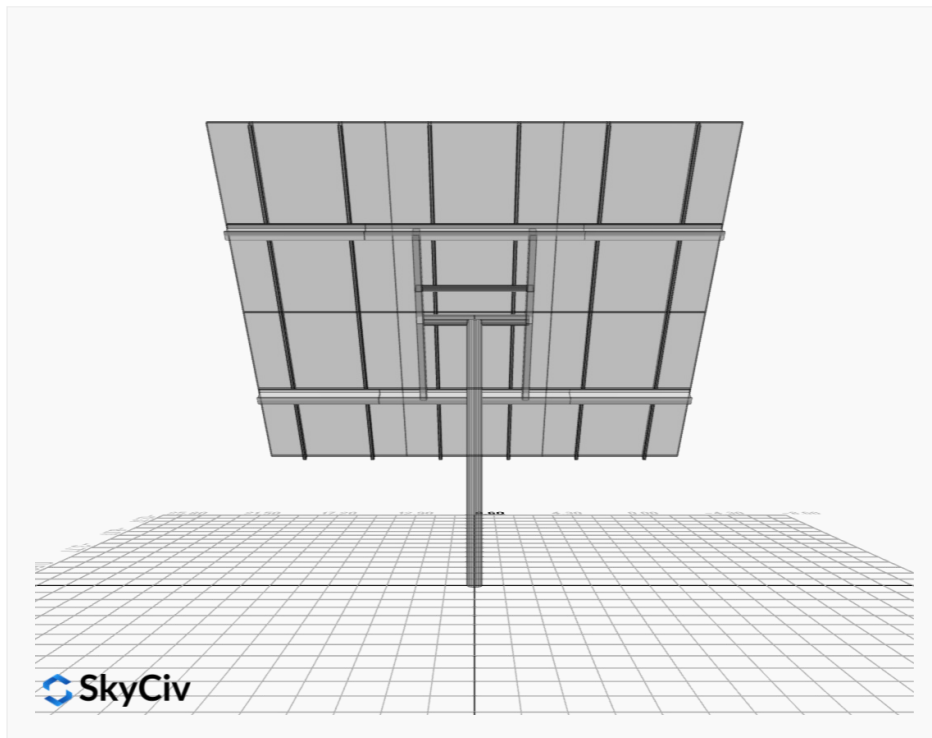

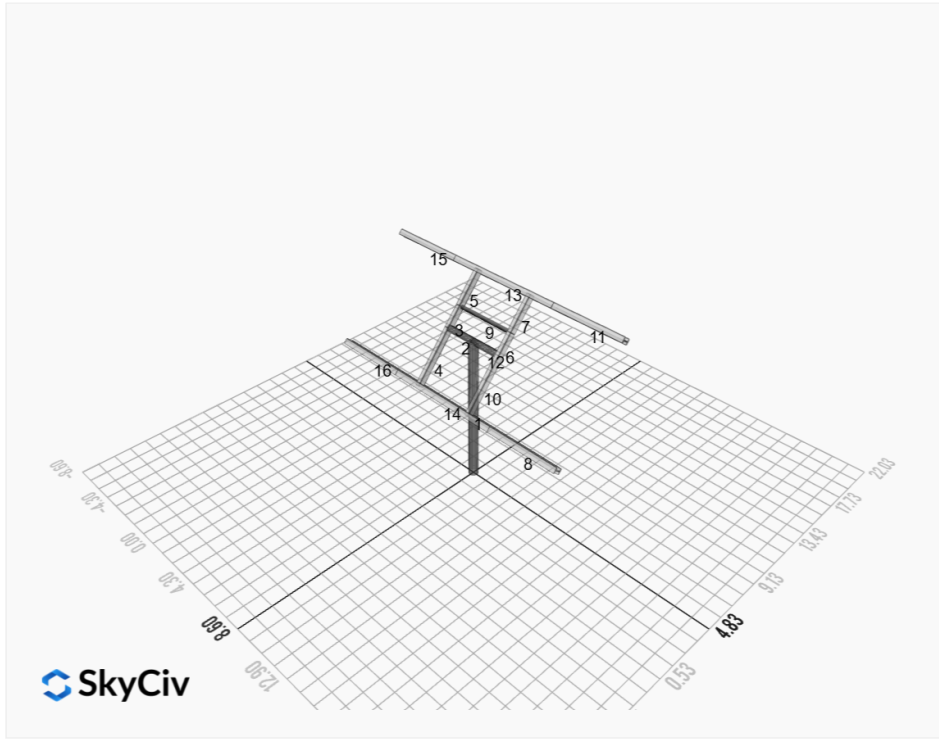
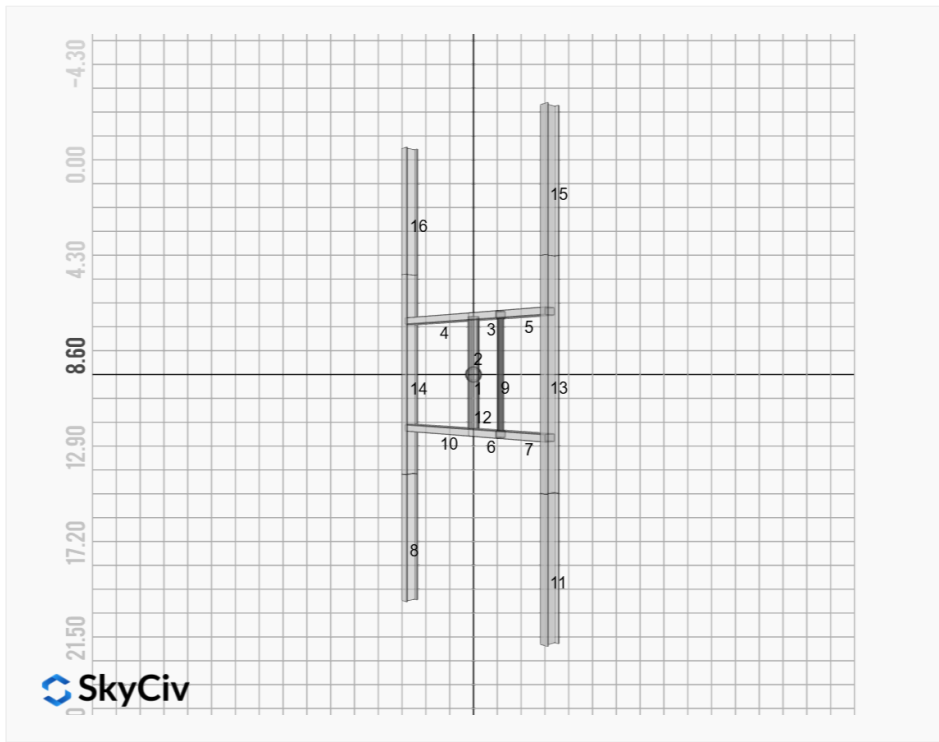

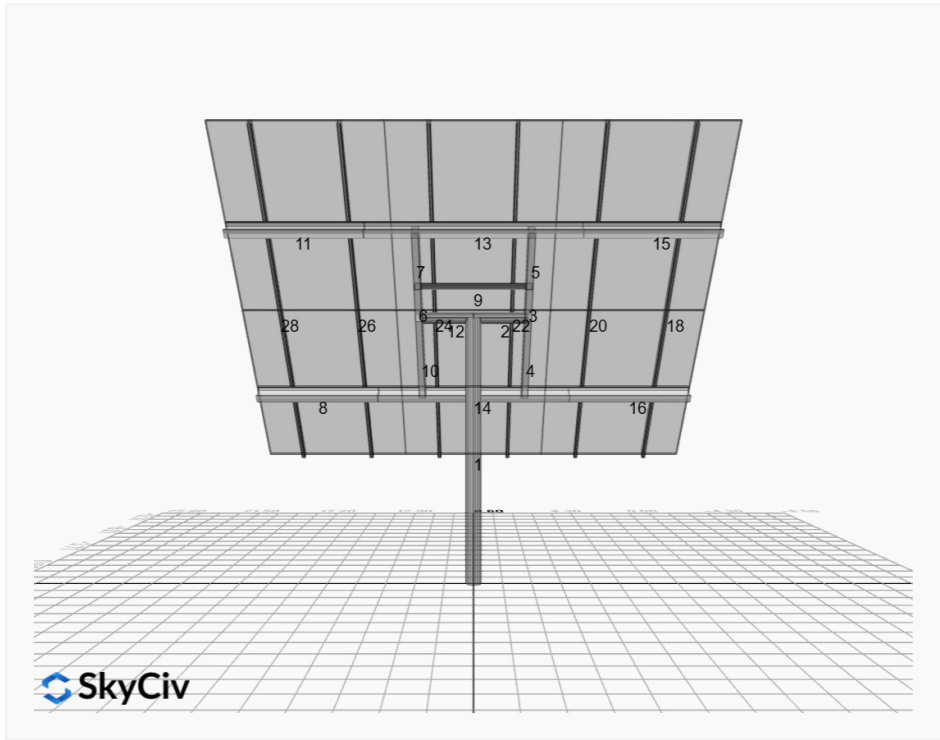

## Rail Design Check

**Rail Length:** 15.033333333333333 ft  
**Additional Restraints Required:** None  
**Tributary Width:** 2.866666666666667 ft  
**Material:** Aluminium  
**Density:** 169 lb/ft<sup>3</sup>  
**Elasticity Modulus:** 10000 ksi  
**Fy:** 34.5 ksi  
**Fu:** 37 ksi  
**Snow (X):** 0.0365 kip/ft  
**Snow (Y):** -0.0435 kip/ft  
**Wind uplift Case A:** 0.0437 kip/ft  
**Wind downforce Case A:** 0.0437 kip/ft  
**Dead (Panel load) (X):** 0.0087 kip/ft  
**Dead (Panel load) (Y):** -0.0103 kip/ft

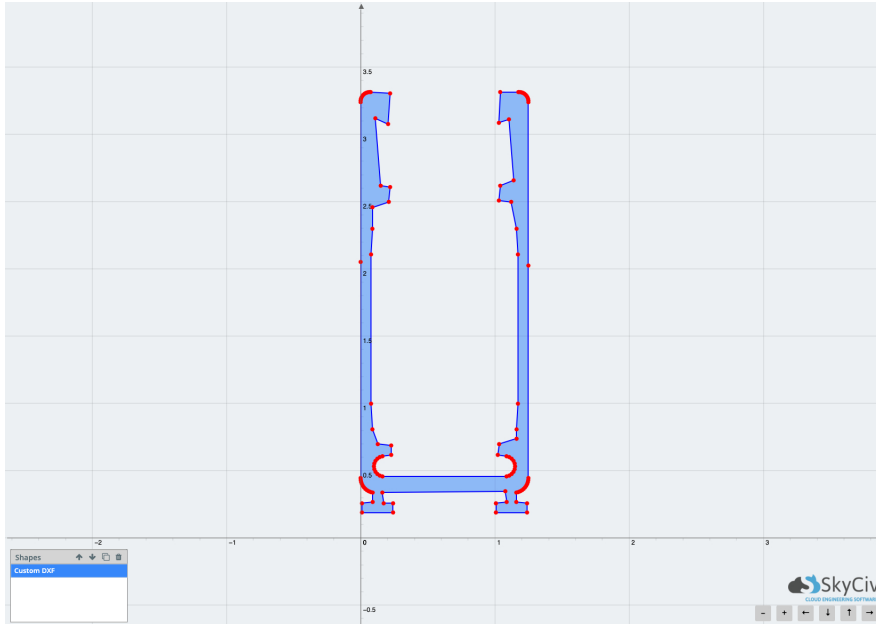

Result Check	Max Limit	Max Value	Utility	Status
Custom Stress Limit	34.5	16.19579843	0.469	PASS
Material Yield	34.5	16.19579843	0.469	PASS
Material Strength	37	16.19579843	0.438	PASS

Member 1, ULS: 1. 1.4D

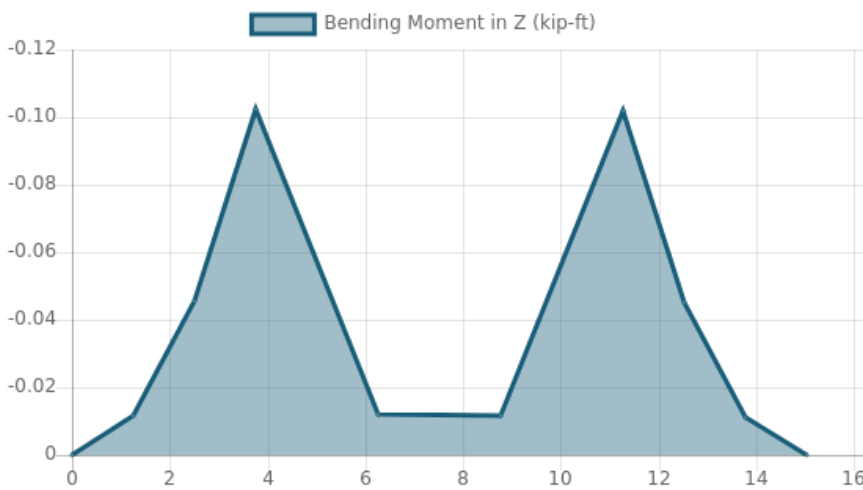

# FEM Results (Envelope Worst Case for each member)

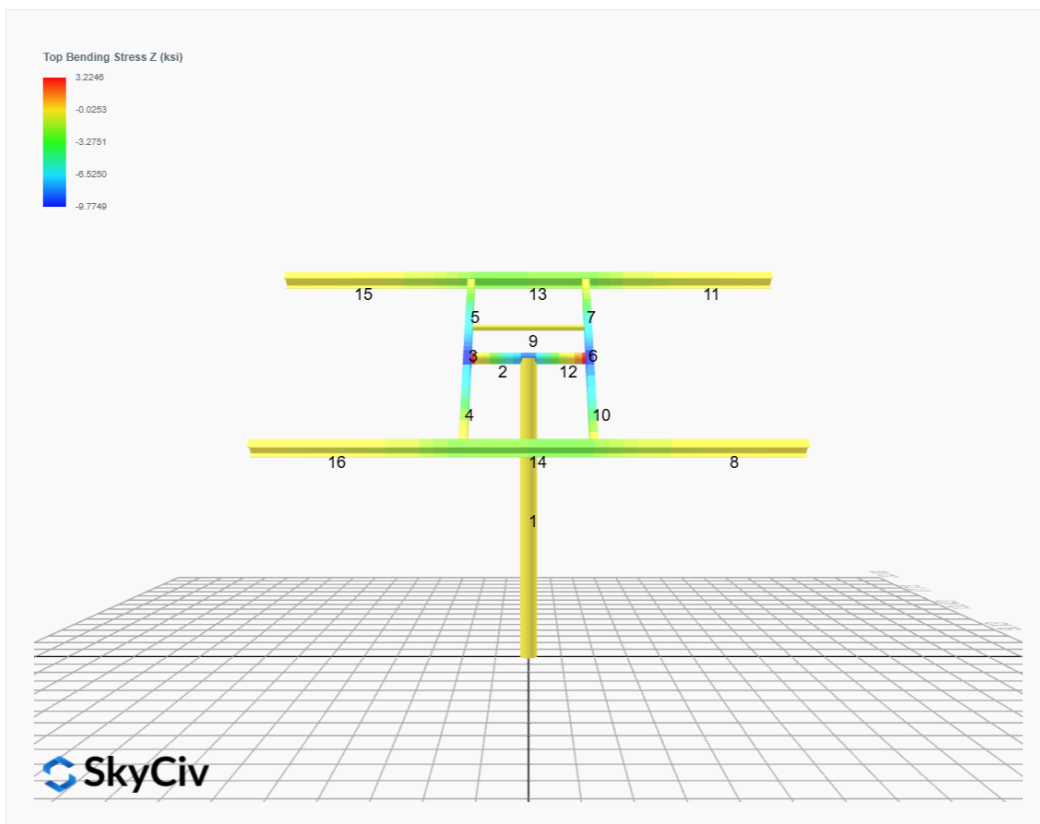
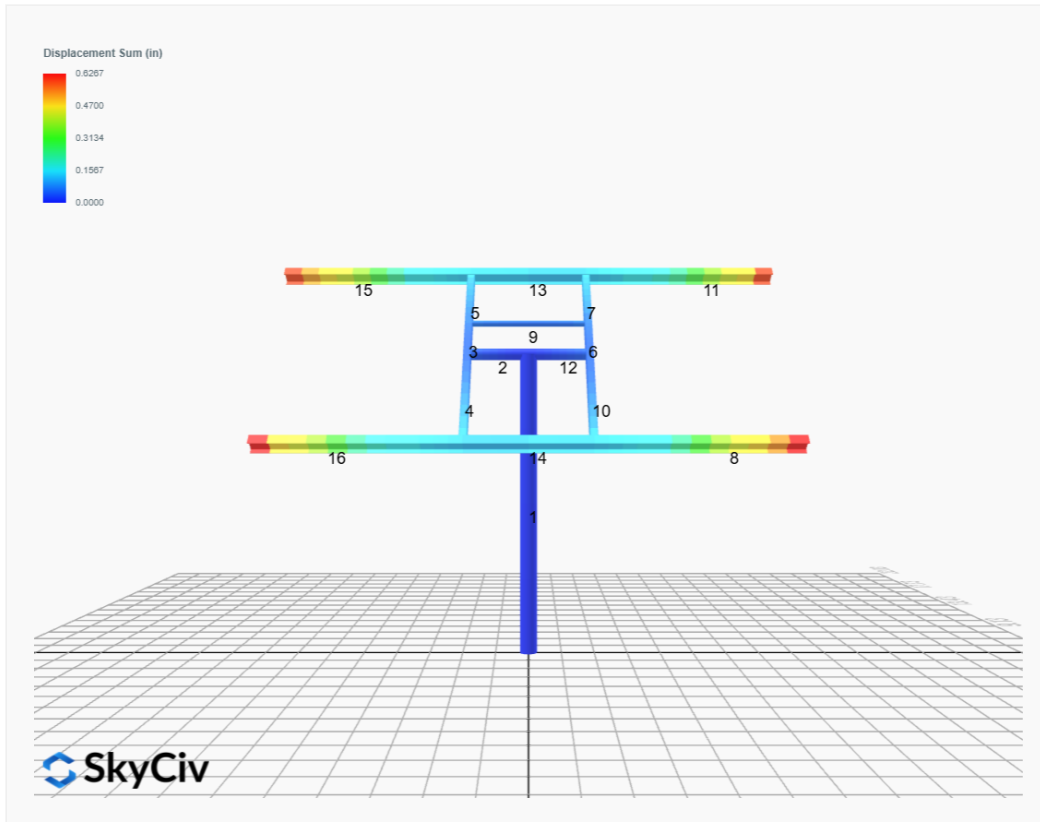

Top Bending Stress Y (ksi)

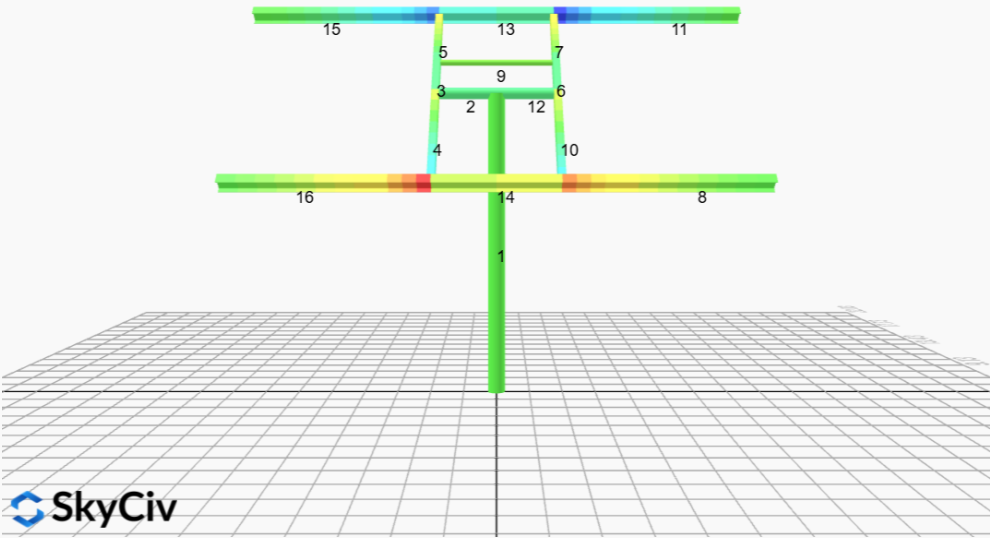

Shear Stress Y (ksi)

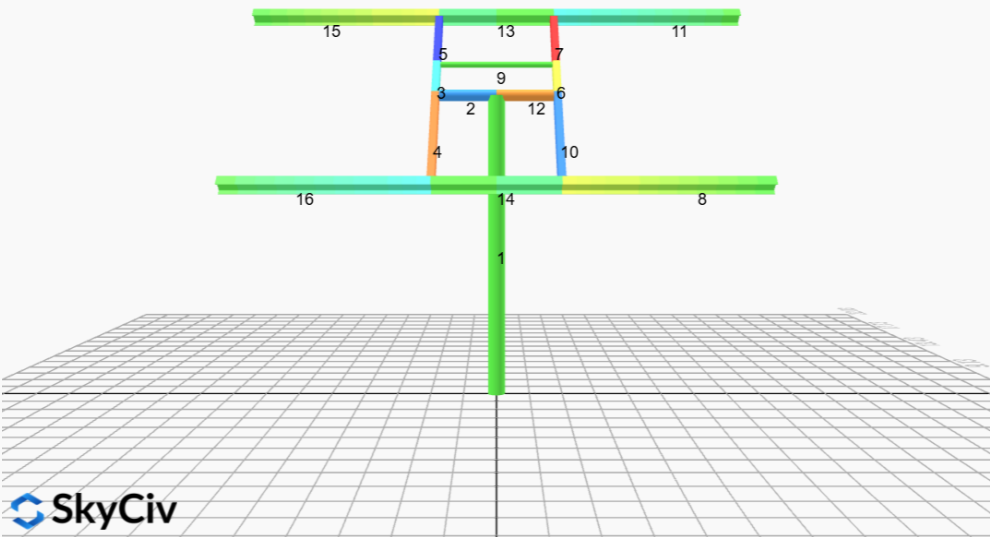

Axial Stress (ksi)

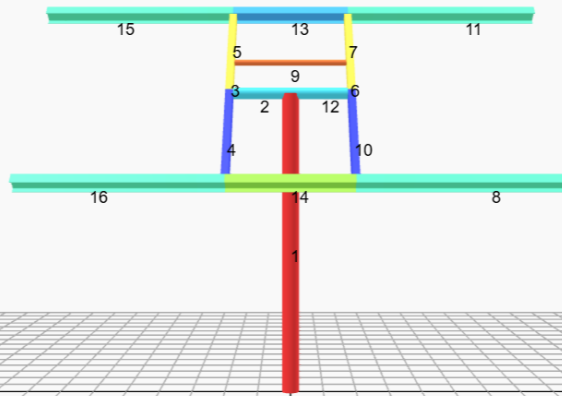

## Reaction Forces for Foundation 1 (Node ID#1), (kip, kip-ft)

### ASD Load Combination Results

Name	Fx	Fy	Fz	Mx	My	Mz
ULS: 1. D	0.0000	1.8579	0.0000	0.0000	-0.0000	0.0163
ULS: 2. D + L	0.0000	1.8579	0.0000	0.0000	-0.0000	0.0163
ULS: 3. D + (S or Lr or R)	0.0000	5.1095	0.0000	0.0000	-0.0000	0.0356
ULS: 3. D + (S or Lr or R)	0.0000	1.8579	0.0000	0.0000	-0.0000	0.0163
ULS: 4. D + 0.75L + 0.75(S or Lr or R)	0.0000	4.2966	0.0000	0.0000	-0.0000	0.0308
ULS: 4. D + 0.75L + 0.75(S or Lr or R)	0.0000	1.8579	0.0000	0.0000	-0.0000	0.0163
ULS: 5b. D + 0.7E	0.0000	1.8579	0.0000	0.0000	-0.0000	0.0163
ULS: 6b. D + 0.75L + 0.75(0.7)E + 0.75S	0.0000	4.2966	0.0000	0.0000	-0.0000	0.0308
ULS: 8. 0.6D + 0.7E	0.0000	1.1147	0.0000	0.0000	-0.0000	0.0098
ULS: 5a. D + 0.6W_Wind downforce Case A only	-1.8134	3.3795	0.0000	0.0000	-0.0000	17.9676
ULS: 5a. D + 0.6W_Wind downforce Case B only	0.0000	1.8579	0.0000	0.0000	-0.0000	0.0163
ULS: 5a. D + 0.6W_Wind uplift Case A only	1.8134	0.3362	0.0000	0.0000	-0.0000	-17.4323
ULS: 5a. D + 0.6W_Wind uplift Case B only	0.0000	1.8579	0.0000	0.0000	-0.0000	0.0163
ULS: 6a. D + 0.75L + 0.75(0.6)W + 0.75(S or Lr or R)_Wind downforce Case A only	-1.3601	5.4378	0.0000	0.0000	-0.0000	13.4943
ULS: 6a. D + 0.75L + 0.75(0.6)W + 0.75(S or Lr or R)_Wind downforce Case B only	0.0000	4.2966	0.0000	0.0000	-0.0000	0.0308
ULS: 6a. D + 0.75L + 0.75(0.6)W + 0.75(S or Lr or R)_Wind uplift Case A only	1.3601	3.1553	0.0000	0.0000	-0.0000	-13.0556
ULS: 6a. D + 0.75L + 0.75(0.6)W + 0.75(S or Lr or R)_Wind uplift Case B only	0.0000	4.2966	0.0000	0.0000	-0.0000	0.0308
ULS: 6a. D + 0.75L + 0.75(0.6)W + 0.75(S or Lr or R)_Wind downforce Case A only	-1.3601	2.9991	0.0000	0.0000	-0.0000	13.4798
ULS: 6a. D + 0.75L + 0.75(0.6)W + 0.75(S or Lr or R)_Wind downforce Case B only	0.0000	1.8579	0.0000	0.0000	-0.0000	0.0163
ULS: 6a. D + 0.75L + 0.75(0.6)W + 0.75(S or Lr or R)_Wind uplift Case A only	1.3601	0.7166	0.0000	0.0000	-0.0000	-13.0701
ULS: 6a. D + 0.75L + 0.75(0.6)W + 0.75(S or Lr or R)_Wind uplift Case B only	0.0000	1.8579	0.0000	0.0000	-0.0000	0.0163
ULS: 7. 0.6D + 0.6W_Wind downforce Case A only	-1.8134	2.6364	0.0000	0.0000	-0.0000	17.9611
ULS: 7. 0.6D + 0.6W_Wind downforce Case B only	0.0000	1.1147	0.0000	0.0000	-0.0000	0.0098
ULS: 7. 0.6D + 0.6W_Wind uplift Case A only	1.8134	-0.4069	0.0000	0.0000	-0.0000	-17.4388
ULS: 7. 0.6D + 0.6W_Wind uplift Case B only	0.0000	1.1147	0.0000	0.0000	-0.0000	0.0098

### Worst Case Reactions LRFD

These calculations are taken directly from the FEA via SkyCiv and are used in the Concrete Checks of the Foundation Module.

Note: Worst case values are assumed as downforce wind load cases.

Result	Value (kip, kip-ft)
Axial	8.7000
Shear X	-3.0224
Shear Z	0.0000
Moment X	0.0000
Moment Y (Twist)	0.0000
Moment Z	30.6776

### Worst Case Reactions ASD

These results are taken from the worst case values in the above table and are used in the Soil Checks in the Foundation Module.

Note: Worst case values are assumed as downforce wind load cases.

Result	Value (kip, kip-ft)
Axial	5.4378
Shear X	-1.8134
Shear Z	0.0000
Moment X	0.0000
Moment Y (Twist)	0.0000
Moment Z	17.9676

## Project Details

Design Code: AISC 360-16 LRFD  
 Provision: LRFD  
 Country: United States  
 User Name: sales@mtsolar.us  
 Unit System: imperial



## Design Input Information

Design Factors			
$\Phi_t$	$\Phi_c$	$\Phi_b$	$\Phi_v$
0.9	0.9	0.9	0.9

Design Materials			
ID	E (ksi)	F <sub>y</sub> (ksi)	F <sub>u</sub> (ksi)
1	29000	50	65

### Section Dimensions

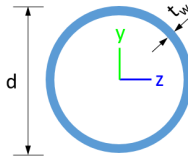

ID	Name	d (in)	t <sub>w</sub> (in)				
1	2in Pipe Sch 40	2.38	0.15				
4	4in Pipe Sch 40	4.50	0.24				
7	6in Pipe Sch 40	6.63	0.28				

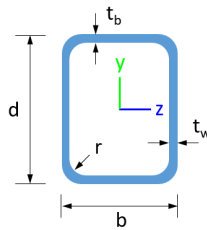

ID	Name	d (in)	b (in)	t <sub>w</sub> (in)	t <sub>b</sub> (in)	r (in)	
15	HSS5x3x1/8	5.00	3.00	0.12	0.12	0.12	

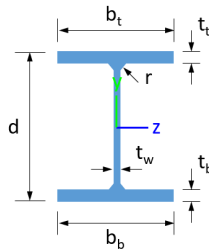

ID	Name	d (in)	t <sub>w</sub> (in)	b <sub>t</sub> (in)	b <sub>b</sub> (in)	t <sub>t</sub> (in)	t <sub>b</sub> (in)	r (in)
18	W6x9	5.90	0.17	3.94	3.94	0.21	0.21	0.25

### Section Properties

ID	Name	A (in <sup>2</sup> )	J (in <sup>4</sup> )	I <sub>yp</sub> (in <sup>4</sup> )	I <sub>zp</sub> (in <sup>4</sup> )	I <sub>w</sub> (in <sup>6</sup> )	S <sub>yp</sub> (in <sup>3</sup> )	S <sub>zp</sub> (in <sup>3</sup> )
----	------	----------------------	----------------------	------------------------------------	------------------------------------	-----------------------------------	------------------------------------	------------------------------------



15	120.60	34.69	23.36	6.45	30.09	45.74
16	120.60	34.69	23.36	6.45	30.09	45.74

## Design Ratio

Member ID	P	M <sub>z</sub>	M <sub>y</sub>	V <sub>y</sub>	V <sub>z</sub>	(P,M <sub>z</sub> ,M <sub>y</sub> )	Worst LC	KL/r	δ	Status
1	0.083	0.725	0.000	0.040	0.000	0.756	#13	0.548	Not Required	Pass
2	0.006	0.399	0.208	0.099	0.035	0.559	#21	0.034	Not Required	Pass
3	0.018	0.567	0.111	0.056	0.006	0.687	#21	0.044	Not Required	Pass
4	0.017	0.561	0.374	0.056	0.062	0.809	#21	0.078	Not Required	Pass
5	0.018	0.352	0.392	0.056	0.079	0.457	#21	0.073	Not Required	Pass
6	0.018	0.567	0.111	0.056	0.006	0.688	#21	0.044	Not Required	Pass
7	0.018	0.352	0.392	0.056	0.079	0.457	#21	0.073	Not Required	Pass
8	0.000	0.092	0.277	0.030	0.016	0.369	#21	Not Required	Not Required	Pass
9	0.028	0.036	0.065	0.001	0.000	0.109	#21	0.198	Not Required	Pass
10	0.017	0.561	0.374	0.056	0.062	0.809	#21	0.078	Not Required	Pass
11	0.000	0.092	0.277	0.030	0.016	0.369	#21	Not Required	Not Required	Pass
12	0.006	0.399	0.208	0.099	0.035	0.559	#21	0.034	Not Required	Pass
13	0.011	0.228	0.519	0.041	0.023	0.741	#21	0.177	Not Required	Pass
14	0.012	0.232	0.519	0.041	0.023	0.741	#21	0.265	Not Required	Pass
15	0.000	0.092	0.277	0.030	0.016	0.369	#21	Not Required	Not Required	Pass
16	0.000	0.092	0.277	0.030	0.016	0.369	#21	Not Required	Not Required	Pass

## Definitions

Φ <sub>t</sub>	Safety factor for tensile
Φ <sub>c</sub>	Safety factor for compression
Φ <sub>b</sub>	Safety factor for flexure
Φ <sub>v</sub>	Safety factor for shear
E	Modulus of elasticity
F <sub>y</sub>	Specified minimum yield stress
F <sub>u</sub>	Specified minimum tensile strength
A	Cross-sectional area
J	Torsional constant
I <sub>yp</sub>	Moment of inertia about the Y axes
I <sub>zp</sub>	Moment of inertia about the Z axes
I <sub>w</sub>	Warping constant
S <sub>yp</sub>	Plastic section modulus about the Y axis
S <sub>zp</sub>	Plastic section modulus about the Z axis
KL	Effective length
C <sub>b</sub>	Buckling modification factor (from all load combinations)
L <sub>b</sub>	Length between braced points
LST	Limited slenderness for tension
LSC	Limited slenderness for compression
LD	Limited deflection
P <sub>n</sub>	Nominal axial strength (tension/compression)
M <sub>n</sub>	Nominal flexural strength (about Z/Y axis)
V <sub>n</sub>	Nominal shear strength (along Z/Y axis)
P	Design ratio in case of axial force
M <sub>z</sub>	Design ratio in case of bending about Z axis
M <sub>y</sub>	Design ratio in case of bending about Y axis
V <sub>y</sub>	Design ratio in case of shear along Y axis
V <sub>z</sub>	Design ratio in case of shear along Z axis
(P,M <sub>z</sub> ,M <sub>y</sub> )	Design ratio in case of axial force and bending action
KL/r	Design ratio in case of section slenderness
δ	Design ratio in case of member deflection
OK	Capacity is provided
NG	Capacity is not provided



REFERENCES	CALCULATIONS	RESULTS
------------	--------------	---------

## SkyCiv Foundation Design

Pile Foundation

### Design Information :

Design code : IBC 2021 (International Building Code)  
Unit System : Imperial

### Pile Input

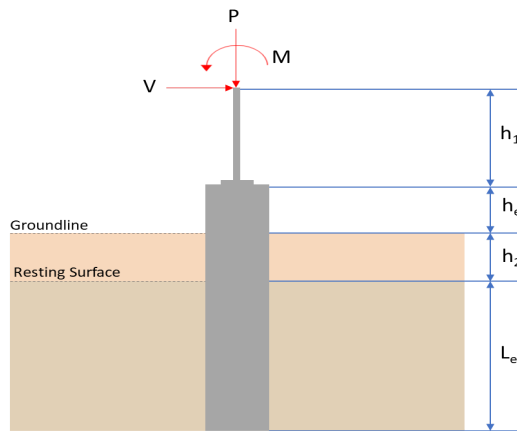

### Geometry

Pile shape: rectangular

$b = 48$  in - Pile width

$D = 48$  in - Pile depth

$L = 5.5$  ft - Total pile length

$h_1 = 0$  ft - Lateral load height from the top of the pile,

$h_2 = 0$  ft - Depth to resisting surface

$h_e = 0$  ft - Length of pile above the ground

### Tabulation of Soil Parameters

Layer	Label	Allowable Bearing Pressure ( $q_a$ ) (psf)	Allowable Lateral Pressure ( $R$ ) (psf/ft)
1	Sand, silty sand, clayey sand, silty gravel & clayey gravel	2000.000	150.000

### Tabulation of Loads

Load Component	ASD	LRFD
$P$ (kip)	5.438	8.700
$V_x$ (kip)	-1.813	-3.022
$V_z$ (kip)	0.000	0.000
$M_x$ (kipft)	0.000	0.000
$M_z$ (kipft)	17.968	30.678

### Material Properties

$f'_{ck} = 2.5$  ksi - Concrete strength.

### Required depth to resist lateral loads (ASD)

$H$  - Point of application of the lateral load

$$H = h_1 + h_2 + h_e$$

$$H = (0 \text{ ft}) + (0 \text{ ft}) + (0 \text{ ft})$$

$$H = 0 \text{ ft}$$

### Considering x-direction:

$H_o$  - Lateral force per length of pile,

$$H_o = \frac{V_x}{1.57 D}$$

$$H_o = \frac{(-1.813 \text{ kip})}{1.57 \times (48 \text{ in})}$$

$$H_o = -0.28869 \text{ kip/ft}$$

$M_o$  - Moment per length of pile,

$$M_o = \frac{M_z + (V_x H)}{1.57 D}$$

$$M_o = \frac{(17.968 \text{ kipft}) + ((-1.813 \text{ kip}) \times (0 \text{ ft}))}{1.57 \times (48 \text{ in})}$$

$$M_o = 2.8611 \text{ kipft/ft}$$

Required depth of embedment in earth:

$$L_x^3 - \left(14.14 \times \frac{H_o \times L_x}{R}\right) - \left(18.85 \times \frac{M_o}{R}\right) = 0$$

Solving the cubic equation:

$L_{e,x} = 5.1818 \text{ ft}$  - Required depth in x-direction,

**Considering z-direction:**

$L_{e,z} = 0 \text{ ft}$  - Required depth in z-direction,

**Minimum embedded depth required:**

$L_{e,req}$  - Depth of pile required,

$$L_{e,req} = \text{MAX}[L_{e,x}, L_{e,z}]$$

$$L_{e,req} = \text{MAX}[(5.1818 \text{ ft}), (0 \text{ ft})]$$

$$L_{e,req} = 5.182 \text{ ft}$$

$L_e$  - Actual embedded length of pile,

$$L_e = L - h_e - h_2$$

$$L_e = (5.5 \text{ ft}) - (0 \text{ ft}) - (0 \text{ ft})$$

$$L_e = 5.5 \text{ ft}$$

Ratio - Embedded depth

$$\text{Ratio} = \frac{L_{e,req}}{L_e}$$

$$\text{Ratio} = \frac{(5.182 \text{ ft})}{(5.5 \text{ ft})}$$

$$\text{Ratio} = 0.94218$$

Status: **PASS**  
Ratio: **0.940**

### End-bearing Capacity (ASD)

$A$  - Pile cross-section area

$$A = b D$$

$$A = (48 \text{ in}) \times (48 \text{ in})$$

$$A = 16 \text{ ft}^2$$

$q$  - End-bearing pressure

$$q = \frac{P_v}{A}$$

$$q = \frac{(5.438 \text{ kip})}{(16 \text{ ft}^2)}$$

$$q = 0.33988 \text{ kip/ft}^2$$

**Check bearing capacity ratio:**

Ratio - Capacity

$$\text{Ratio} = \frac{q}{q_a}$$

$$\text{Ratio} = \frac{(0.33988 \text{ kip/ft}^2)}{(2000 \text{ psf})}$$

$$\text{Ratio} = 0.16994$$

Status: **PASS**  
Ratio: **0.170**

Czerniak

### Lateral Soil Pressure (ASD):

$L/D$  - Length to least lateral dimension ratio,

$$L/D = \frac{L}{D}$$

$$L/D = \frac{(5.5 \text{ ft})}{(48 \text{ in})}$$

$$L/D = 1.375$$

Since  $L/D \leq 10$ ,

Pile is short.

**Considering x-direction:**

$H_o = -0.28869 \text{ kip/ft}$  - Lateral force per length of pile,

$M_o = 2.8611 \text{ kipft/ft}$  - Overturning moment per length of pile,

$a$  - Distance from resting surface to pivot point,

$$a = \frac{(4 M_o L_e) + (3 H_o L_e^2)}{(6 M_o) + (4 H_o L_e)}$$

$$a = \frac{(4 \times (2.8611 \text{ kipft/ft}) \times (5.5 \text{ ft})) + (3 \times (-0.28869 \text{ kip/ft}) \times (5.5 \text{ ft})^2)}{(6 \times (2.8611 \text{ kipft/ft})) + (4 \times (-0.28869 \text{ kip/ft}) \times (5.5 \text{ ft}))}$$

$$a = 3.7904 \text{ ft}$$

$p$  - Earth pressure against the pile at distance  $a/2$  from resting surface,

$$p = \frac{0.75 [(4 M_o) + (3 H_o L_e)]^2}{L_e^2 [(3 M_o) + (2 H_o L_e)]}$$

$$p = \frac{0.75 \times [(4 \times (2.8611 \text{ kipft/ft})) + (3 \times (-0.28869 \text{ kip/ft}) \times (5.5 \text{ ft}))]^2}{(5.5 \text{ ft})^2 \times [(3 \times (2.8611 \text{ kipft/ft})) + (2 \times (-0.28869 \text{ kip/ft}) \times (5.5 \text{ ft}))]}$$

$$p = 0.20465 \text{ kip/ft}^2$$

$s$  - Earth pressure against the pile at distance  $L_e$ ,

$$s = \frac{6 [(2 M_o) + (H_o L_e)]}{L_e^2}$$

$$s = \frac{6 \times [(2 \times (2.8611 \text{ kipft/ft})) + ((-0.28869 \text{ kip/ft}) \times (5.5 \text{ ft}))]}{(5.5 \text{ ft})^2}$$

$$s = 0.82006 \text{ kip/ft}^2$$

**Check lateral soil pressure capacity:**

$p_a$  - Allowable lateral soil pressure at depth  $a/2$ ,

$$p_a = R \frac{a}{2}$$

$$p_a = (150 \text{ psf/ft}) \times \frac{(3.7904 \text{ ft})}{2}$$

$$p_a = 0.28428 \text{ kip/ft}^2$$

*Ratio* - Lateral soil capacity

$$\text{Ratio} = \frac{p}{p_a}$$

$$\text{Ratio} = \frac{(0.20465 \text{ kip/ft}^2)}{(0.28428 \text{ kip/ft}^2)}$$

$$\text{Ratio} = 0.71989$$

$p_s$  - Allowable lateral soil pressure at depth  $L_e$ ,

$$p_s = R L_e$$

$$p_s = (150 \text{ psf/ft}) \times (5.5 \text{ ft})$$

$$p_s = 0.825 \text{ kip/ft}^2$$

*Ratio* - Lateral soil capacity

$$\text{Ratio} = \frac{s}{p_s}$$

$$\text{Ratio} = \frac{(0.82006 \text{ kip/ft}^2)}{(0.825 \text{ kip/ft}^2)}$$

Status: **PASS**  
Ratio: **0.720**

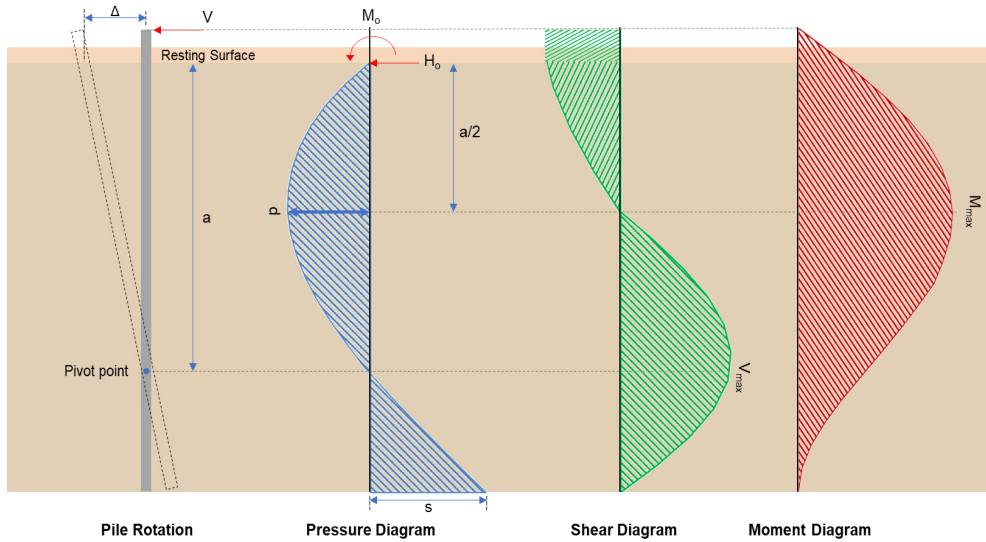

**Shear force and Bending moment (x-direction, LRFD)**

$H_o$  - Lateral force per length of pile,

$$H_o = \frac{V_x}{1.57 D}$$

$$H_o = \frac{(-3.022 \text{ kip})}{1.57 \times (48 \text{ in})}$$

$$H_o = -0.48121 \text{ kip/ft}$$

$M_o$  - Moment per length of pile,

$$M_o = \frac{M_z + (V_x H)}{1.57 D}$$

$$M_o = \frac{(30.678 \text{ kipft}) + ((-3.022 \text{ kip}) \times (0 \text{ ft}))}{1.57 \times (48 \text{ in})}$$

$$M_o = 4.885 \text{ kipft/ft}$$

$E$  - Distance from lateral load to resisting surface,

$$E = \frac{M_o}{H_o}$$

$$E = \frac{(4.885 \text{ kipft/ft})}{(-0.48121 \text{ kip/ft})}$$

$$E = 10.152 \text{ ft}$$

$a$  - Distance from resting surface to pivot point,

$$a = \frac{(4 M_o L_e) + (3 H_o L_e^2)}{(6 M_o) + (4 H_o L_e)}$$

$$a = \frac{(4 \times (4.885 \text{ kipft/ft}) \times (5.5 \text{ ft})) + (3 \times (-0.48121 \text{ kip/ft}) \times (5.5 \text{ ft})^2)}{(6 \times (4.885 \text{ kipft/ft})) + (4 \times (-0.48121 \text{ kip/ft}) \times (5.5 \text{ ft}))}$$

$$a = 3.7883 \text{ ft}$$

$V_{max}$  - Max shear force located at depth  $a$ ,

$$V_{max} = (H_o D) \left[ 1 - \left[ 3 \left( \frac{4E}{L_e} + 3 \right) \left( \frac{a}{L_e} \right)^2 \right] + \left[ 4 \left( \frac{3E}{L_e} + 2 \right) \left( \frac{a}{L_e} \right)^3 \right] \right]$$

$$V_{max} = ((-0.48121 \text{ kip/ft}) \times (48 \text{ in})) \times \left[ 1 - \left[ 3 \times \left( \frac{4 \times (10.152 \text{ ft})}{(5.5 \text{ ft})} + 3 \right) \times \left( \frac{(3.7883 \text{ ft})}{(5.5 \text{ ft})} \right)^2 \right] + \left[ 4 \times \left( \frac{3 \times (10.152 \text{ ft})}{(5.5 \text{ ft})} + 2 \right) \times \left( \frac{(3.7883 \text{ ft})}{(5.5 \text{ ft})} \right)^3 \right] \right]$$

$$v_{max} = 1.5000 \text{ kip}$$

$M_{max}$  - Max bending moment located at depth  $a/2$ ,

$$M_{max} = (H_o D L_e) \left[ \left( \frac{E}{L_e} + \frac{a}{2 L_e} \right) - \left[ \left( \frac{4 E}{L_e} + 3 \right) \left( \frac{a}{2 L_e} \right)^3 + \left[ \left( \frac{3 E}{L_e} + 2 \right) \left( \frac{a}{2 L_e} \right)^4 \right] \right]$$

$$M_{max} = ((-0.48121 \text{ kip/ft}) \times (48 \text{ in}) \times (5.5 \text{ ft})) \times \left[ \left( \frac{(10.152 \text{ ft})}{(5.5 \text{ ft})} + \frac{(3.7883 \text{ ft})}{2 \times (5.5 \text{ ft})} \right) - \left[ \left( \frac{4 \times (10.152 \text{ ft})}{(5.5 \text{ ft})} + 3 \right) \times \left( \frac{(3.7883 \text{ ft})}{2 \times (5.5 \text{ ft})} \right)^3 + \left[ \left( \frac{3 \times (10.152 \text{ ft})}{(5.5 \text{ ft})} + 2 \right) \times \left( \frac{(3.7883 \text{ ft})}{2 \times (5.5 \text{ ft})} \right)^4 \right] \right]$$

$$M_{max} = 19.819 \text{ kipft}$$

### Minimum Reinforcement Check (LRFD)

#### Parameters:

$f'_{ck} = 2.5 \text{ ksi}$  - Concrete strength,  
 $f_{yk} = 60 \text{ ksi}$  - Longitudinal reinforcement strength,  
 $\phi = 0.65$  - Reduction factor for axial strength,  
 $\alpha = 0.8$  - Alpha factor for axial strength,  
 $A_g = 2304 \text{ in}^2$  - Gross area of concrete,

Table 22.4.2.1

#### Longitudinal reinforcement:

Required reinforcement due to axial load,  $A_{st,required}$

22.4.2.2, 10.6.1.1

$A_{st,required}$

$$A_{st,required} = \text{Min} \left[ \frac{\frac{P}{\phi \alpha} - (0.85 f'_{ck} A_g)}{f_{yk} - (0.85 f'_{ck})}, (0.08 A_g) \right]$$

$$A_{st,required} = \text{Min} \left[ \frac{\left( \frac{8.7 \text{ kip}}{(0.65) \times (0.8)} - (0.85 \times (2.5 \text{ ksi}) \times (2304 \text{ in}^2)) \right)}{(60 \text{ ksi}) - (0.85 \times (2.5 \text{ ksi}))}, (0.08 \times (2304 \text{ in}^2)) \right]$$

$$A_{st,required} = -84.307 \text{ in}^2$$

$A_{min}$  - Governing minimum reinforcement area,

$$A_{min} = \text{Max} [A_{st,required}, (0.0018 A_g)]$$

$$A_{min} = \text{Max} [(-84.307 \text{ in}^2), (0.0018 \times (2304 \text{ in}^2))]$$

$$A_{min} = 4.1472 \text{ in}^2$$

$n_{rebar}$  - Required number of reinforcement,

$$n_{rebar} = \frac{A_{min}}{A_{rebar}}$$

$$n_{rebar} = \frac{(4.1472 \text{ in}^2)}{(0.3068 \text{ in}^2)}$$

$$n_{rebar} = 14$$

$A_{st}$  - Actual total reinforcement area,

$$A_{st} = n_{rebar} \frac{\pi d_{bar}^2}{4}$$

$$A_{st} = (14) \times \frac{\pi \times (0.625 \text{ in})^2}{4}$$

$$A_{st} = 4.2951 \text{ in}^2$$

Ratio - Capacity

$$\text{Ratio} = \frac{A_{min}}{A_{st}}$$

$$\text{Ratio} = \frac{(4.1472 \text{ in}^2)}{(4.2951 \text{ in}^2)}$$

$$\text{Ratio} = 0.96556$$

25.2.3

$s_{rebar}$  - Minimum spacing of reinforcement,

$$s_{rebar} = \text{Max} [1.5, (1.5 d_{bar})]$$

Status: **PASS**  
Ratio: **0.970**

$$s_{rebar} = Max[1.5, (1.5 \times (0.625 \text{ in}))]$$

$$s_{rebar} = 1.5 \text{ in}$$

**Ties:**

25.7.2.2 Since longitudinal reinforcement is  $\leq$  No. 10 $\emptyset$ : Use #3(0.375 in)

25.7.2.1  $s_{ties}$  - Maximum spacing of ties,

$$s_{ties} = Min[(16 d_{bar}), (48 d_{ties}), Min(D, b)]$$

$$s_{ties} = Min[(16 \times (0.625 \text{ in})), (48 \times (0.375 \text{ in})), Min((48 \text{ in}), (48 \text{ in}))]$$

$$s_{ties} = 10 \text{ in}$$

**Summary:**

Main reinforcement: **14 - #5 (0.625 in)**

Ties: **#3(0.375 in) - 10 in**

**Axial Compression Strength (ACI 318-19, LRFD)**

22.4.2.2  $\phi P_N$  - Allowable axial compressive strength

$$\phi P_N = \phi 0.80 [(0.85 f'_{ck} [A_g - A_{st}]) + (f_{yk} A_{st})]$$

$$\phi P_N = (0.65) \times 0.80 \times [(0.85 \times (2.5 \text{ ksi}) \times [(2304 \text{ in}^2) - (4.2951 \text{ in}^2)]) + ((60 \text{ ksi}) \times (4.2951 \text{ in}^2))]$$

$$\phi P_N = 2675.2 \text{ kip}$$

Ratio - Capacity

$$Ratio = \frac{P}{\phi P_N}$$

$$Ratio = \frac{(8.7 \text{ kip})}{(2675.2 \text{ kip})}$$

$$Ratio = 0.0032521$$

Status: **PASS**  
Ratio: **0.000**

**Shear Strength (ACI 318-19, LRFD)**

**Parameters:**

22.5.2.2  $b_w = 48 \text{ in}$  - Effective width,  
 $d$  - Effective depth

$$d = 0.80 D$$

$$d = 0.80 \times (48 \text{ in})$$

$$d = 38.4 \text{ in}$$

22.5.5.1.3  $\lambda_s$  - size effect modification factor

$$\lambda_s = MIN \left[ \sqrt{\frac{2}{1 + \frac{d}{10}}}, 1 \right]$$

$$\lambda_s = MIN \left[ \sqrt{\frac{2}{1 + \frac{(38.4 \text{ in})}{10}}}, 1 \right]$$

$$\lambda_s = 0.64282$$

The following variables were converted to be consistent with empirical formula  $f'_{ck} = 2.5 \text{ ksi} \rightarrow 2500 \text{ psi}$ ,

22.5.5.1.1  $V_{c,max}$  - Max shear strength of concrete

$$V_{c,max} = 5 \lambda_s \sqrt{f'_{ck}} b_w d$$

$$V_{c,max} = 5 \times (0.64282) \times \sqrt{(2500 \text{ psi})} \times (48 \text{ in}) \times (38.4 \text{ in})$$

$$V_{c,max} = 296.21 \text{ kip}$$

The following variables were converted to be consistent with empirical formula  $f'_{ck} = 2.5 \text{ ksi} \rightarrow 2500 \text{ psi}$ ,  $P = 8.7 \text{ kip} \rightarrow 8700 \text{ lbf}$ ,

22.5.5.1.1(a)  $V_{c,a}$  - Shear strength of concrete (a)

$$V_{c,a} = \left[ 2 \lambda_s \sqrt{f'_{ck}} + \frac{P}{6 A_g} \right] b_w d$$

$$V_{c,a} = \left[ 2 \times (0.64282) \times \sqrt{(2500 \text{ psi})} + \frac{(8700 \text{ lbf})}{6 \times (2304 \text{ in}^2)} \right] \times (48 \text{ in}) \times (38.4 \text{ in})$$

$$V_{c,a} = 119.65 \text{ kip}$$

22.5.5.1.2 The following variables were converted to be consistent with empirical formula  $f'_{ck} = 2.5 \text{ ksi} \rightarrow 2500 \text{ psi}$ ,  
 $V_{c,b}$  - Shear strength of concrete (b)

$$V_{c,b} = \left[ 2 \lambda_s \sqrt{f'_{ck}} + (0.05 f'_{ck}) \right] b_w d$$

$$V_{c,b} = \left[ 2 \times (0.64282) \times \sqrt{(2500 \text{ psi})} + (0.05 \times (2500 \text{ psi})) \right] \times (48 \text{ in}) \times (38.4 \text{ in})$$

$$V_{c,b} = 348.89 \text{ kip}$$

$V_c$  - Governing shear strength of concrete

$$V_c = \text{Min}[V_{c,max}, V_{c,a}, V_{c,b}]$$

$$V_c = \text{Min}[(296.21 \text{ kip}), (119.65 \text{ kip}), (348.89 \text{ kip})]$$

$$V_c = 119.65 \text{ kip}$$

22.5.1.2 The following variables were converted to be consistent with empirical formula  $f'_{ck} = 2.5 \text{ ksi} \rightarrow 2500 \text{ psi}$ ,  
 $V_{s,a}$  - Shear strength of steel (a)

$$V_{s,a} = 8 \sqrt{f'_{ck}} b_w d$$

$$V_{s,a} = 8 \times \sqrt{(2500 \text{ psi})} \times (48 \text{ in}) \times (38.4 \text{ in})$$

$$V_{s,a} = 737.28 \text{ kip}$$

$A_v$  - Ties rebar area,

$$A_v = \frac{\pi d_{ties}^2}{4}$$

$$A_v = \frac{\pi \times (0.375 \text{ in})^2}{4}$$

$$A_v = 0.11045 \text{ in}^2$$

22.5.8.5.3  $V_{s,b}$  - Shear strength of steel (b)

$$V_{s,b} = \frac{2 A_v f_{ywk} d}{s_{ties}}$$

$$V_{s,b} = \frac{2 \times (0.11045 \text{ in}^2) \times (60 \text{ ksi}) \times (38.4 \text{ in})}{(10 \text{ in})}$$

$$V_{s,b} = 50.894 \text{ kip}$$

$V_s$  - Governing shear strength of steel

$$V_s = \text{MIN}[V_{s,a}, V_{s,b}]$$

$$V_s = \text{MIN}[(737.28 \text{ kip}), (50.894 \text{ kip})]$$

$$V_s = 50.894 \text{ kip}$$

22.5.1.1  $\phi V_n$  - Allowable shear strength

$$\phi V_n = \phi (V_c + V_s)$$

$$\phi V_n = (0.65) \times ((119.65 \text{ kip}) + (50.894 \text{ kip}))$$

$$\phi V_n = 110.85 \text{ kip}$$

**Considering x-direction:**

$V_{max} = 7.5566 \text{ kip}$  - Maximum shear force in the x-direction,

Ratio - Capacity

$$\text{Ratio} = \frac{V_{max}}{\phi V_n}$$

$$\text{Ratio} = \frac{(7.5566 \text{ kip})}{(110.85 \text{ kip})}$$

$$\text{Ratio} = 0.06817$$

Status: **PASS**  
Ratio: **0.070**

**Flexural Strength (ACI 318-19, LFRD)** $S_m$  - Section modulus

$$S_m = \frac{b D^2}{6}$$

$$S_m = \frac{(48 \text{ in}) \times (48 \text{ in})^2}{6}$$

$$S_m = 18432 \text{ in}^3$$

 $\lambda = 1$  - Concrete modification factor (Normal concrete),

Allowable flexural strength:

 $M_n$  shall be the lesser of: $\phi M_{n,1}$ 

$$\phi M_{n,1} = \phi \times 5 \times \lambda \times \sqrt{f'_c} \times S_m$$

$$\phi M_{n,1} = 0.65 \times 5 \times 1 \times \sqrt{2.5 \text{ ksi}} \times 18432.001 \text{ in}^3$$

$$\phi M_{n,1} = 249.600 \text{ kipft}$$

14.5.2.1b

 $\phi M_{n,2}$ 

$$\phi M_{n,2} = \phi \times 0.85 \times f'_c \times S_m$$

$$\phi M_{n,2} = (0.65) \times 0.85 \times (2.5 \text{ ksi}) \times (18432 \text{ in}^3)$$

$$\phi M_{n,2} = 2121.6 \text{ kipft}$$

Therefore,

 $\phi M_n$  - Allowable flexural strength,

$$\phi M_n = \text{MIN}[\phi M_{n,1}, \phi M_{n,2}]$$

$$\phi M_n = \text{MIN}[(249.6 \text{ kipft}), (2121.6 \text{ kipft})]$$

$$\phi M_n = 249.6 \text{ kipft}$$

**Considering x-direction:** $M_{max} = 19.819 \text{ kipft}$  - Maximum moment in the x-direction,

Ratio - Capacity

$$\text{Ratio} = \frac{M_{max}}{\phi M_n}$$

$$\text{Ratio} = \frac{(19.819 \text{ kipft})}{(249.6 \text{ kipft})}$$

$$\text{Ratio} = 0.079402$$

Status: **PASS**  
Ratio: **0.080**