

Your Project Calculations



Project Name: ChadLampson-RevB

S3D Model Link:

https://platform.skyciv.com/structural?preload_name=ChadLampson-RevB&preload_path=Shared%20Enterprise%20Folder/MT_Solar_Projects/4_2023

Public Model Link:

https://platform.skyciv.com/structural-viewer?project_id=bnFwfeTvzfl4wRfilHUH3qwEcm5I3jakDIkomIRMe2HRiagKpHvb2ZSkfkWSSaNP

Array Specification

Product:	Beam
Unique ID:	1P-0-8TOP-HD-72-L-5Hx3W-D2B5
Duty Classification:	HD
Module Width:	39.45 in
Module Length:	79.00in
Number of Rows:	5
Number of Columns:	3
Total Number of Modules:	15
Desired Tilt Angle:	45
Front Edge Clearance:	3
Total Array Height at Tilt:	14.70 ft
Total Frame Length:	19.50 ft
Frame Weight:	859 lbs
Array Dimensions N/S:	16.65 ft
Array Dimensions E/W:	20.00 ft
Rail Length:	199.75 in
Rail Spacing:	3.29 ft
Rail Check:	

Support Specifications

Pole Size:	8in Pipe Sch 40
Pole Length above Grade:	8.89 ft
Number of Poles:	1
Pole Spacing:	0

Foundation Specifications

Foundation Type:	Round
Foundation Dimensions:	Ø36 in
Foundation Depth (below grade):	Pile 1: 9.00 ft
Foundation Volume:	2.356 y ³
Foundation Result:	PASSED

Site Info

Risk Category:	I
Exposure:	B
Soil Classification:	sand
Site Location:	67094 Ovaska Rd, Marengo, WI 54855, USA
Wind Speed:	100 mph
Snow Load:	60 psf
Design Uplift Pressure:	Multiple pressures
Design Downforce Pressure:	Multiple pressures
Design Snow Pressure:	0.011663 ksf



Design Disclaimer

This software should be used for preliminary designs and should not be used as a final design unless reviewed, verified and designed by a qualified structural engineer.

AutoDesigner Input

```
{
  "wind_speed_override": null,
  "snow_load_override": null,
  "direct_snow_load": false,
  "product_type": "Beam",
  "project_id": "ChadLampson-RevB",
  "site_address": "67094 Ovaska Rd, Marengo, WI 54855, USA",
  "module_width": 39.45,
  "module_length": 79,
  "number_rows": 5,
  "number_columns": 3,
  "pole_mount_section": "4_40",
  "core_pipe_width": 65,
  "core_pipe_section": "2_40",
  "adjuster_section": "2_40",
  "core_beam_height": 65,
  "core_beam_section": "HSS3x2x1/8",
  "main_pipe_section": "2_12GA",
  "pole_spacing": 15,
  "tilt_angle": 45,
  "ground_clearance": 3,
  "risk_category": "I",
  "exposure_category": "B",
  "frame_duty_override": "auto",
  "pole_override": "auto",
  "soil_type": "sand",
  "foundation_type": "Round",
  "foundation_size": 36,
  "check_rails": true
}
```

Design Notes:

- AISC Deflection checks are set to L/1 due to structure design intent
- Foundation Design and Sizing is approximate only

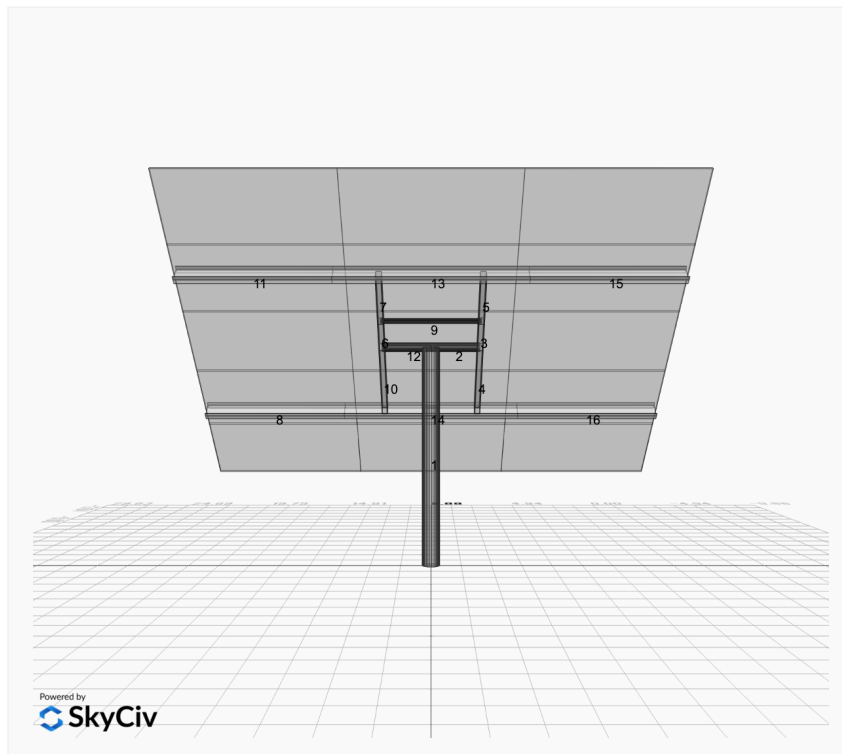

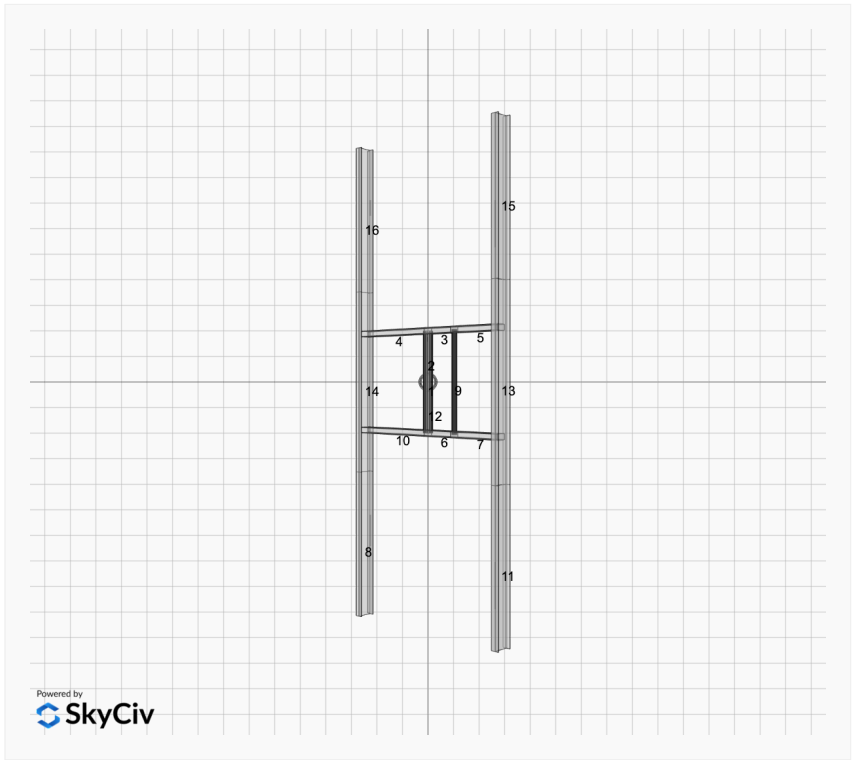
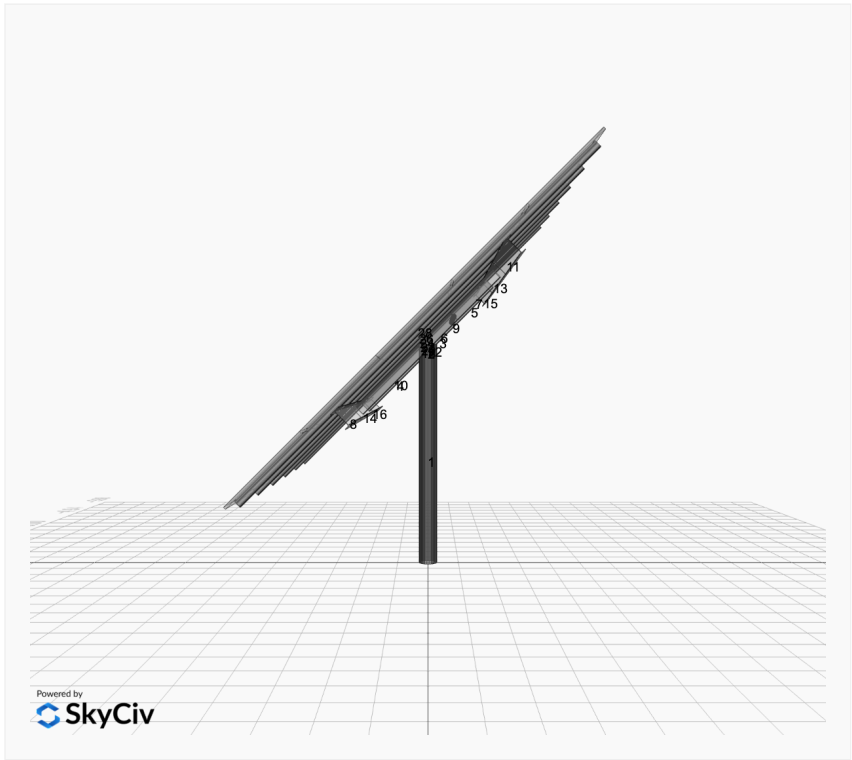

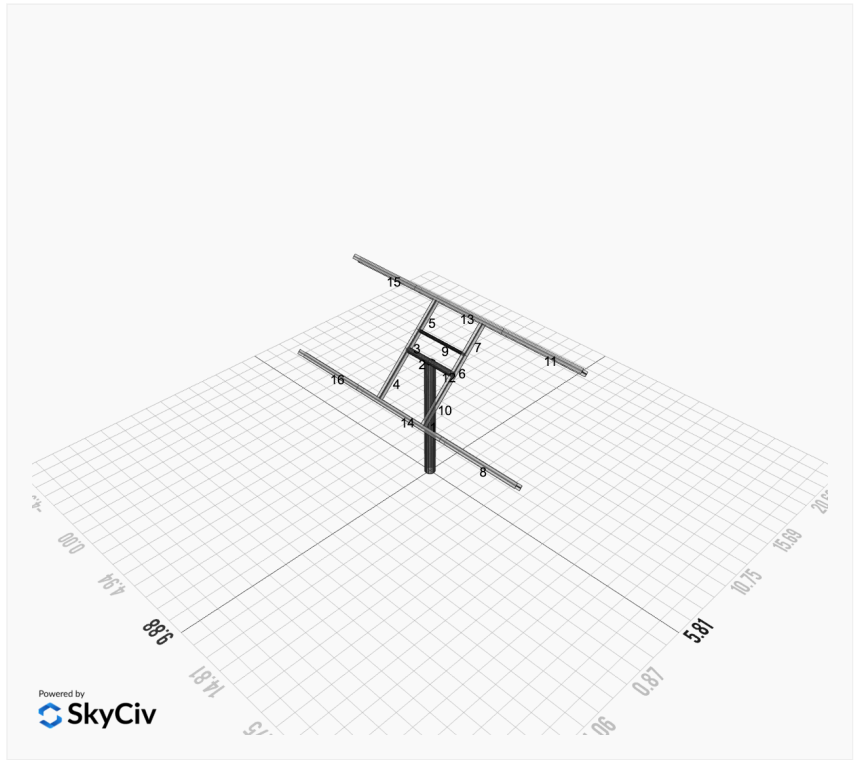

FEM Results (Envelope Worst Case for each member)

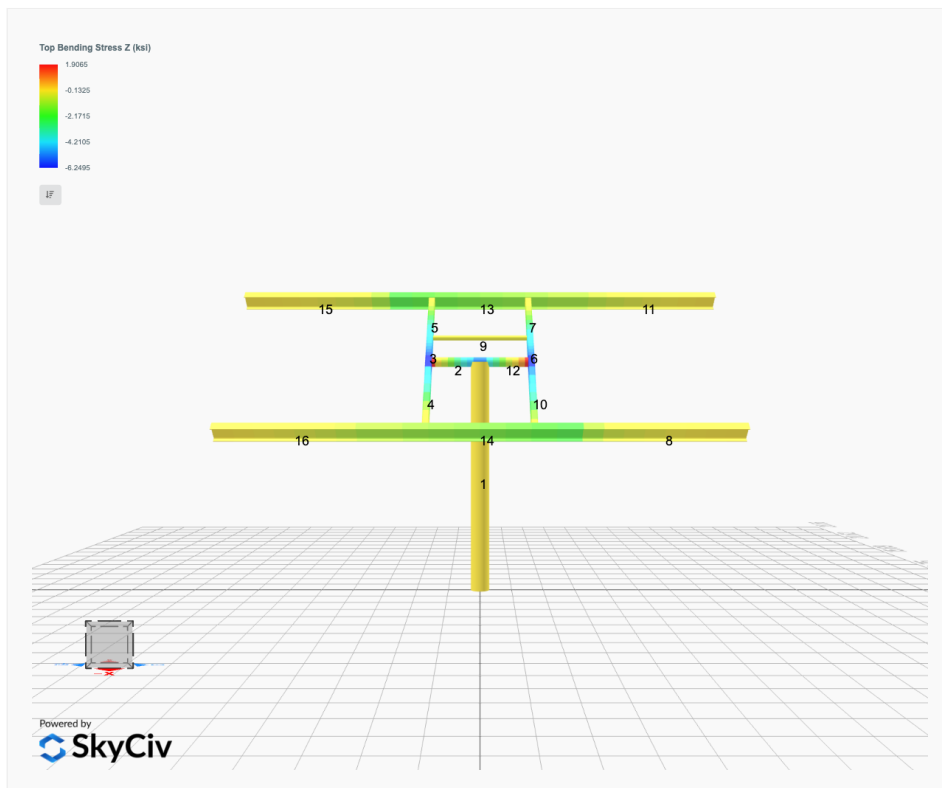
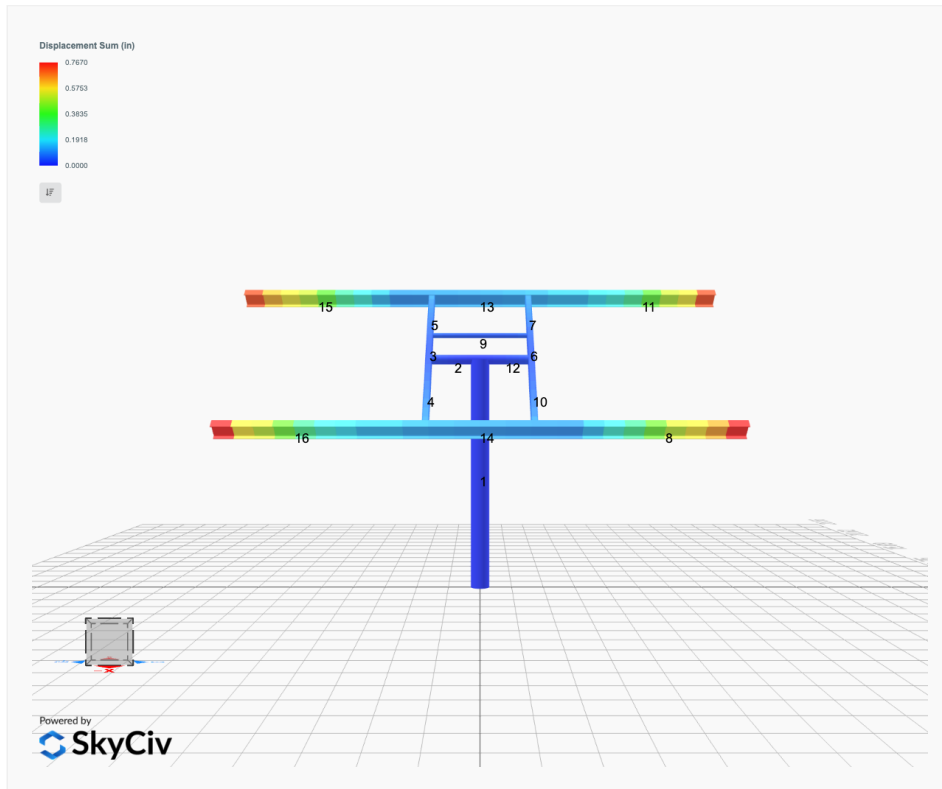

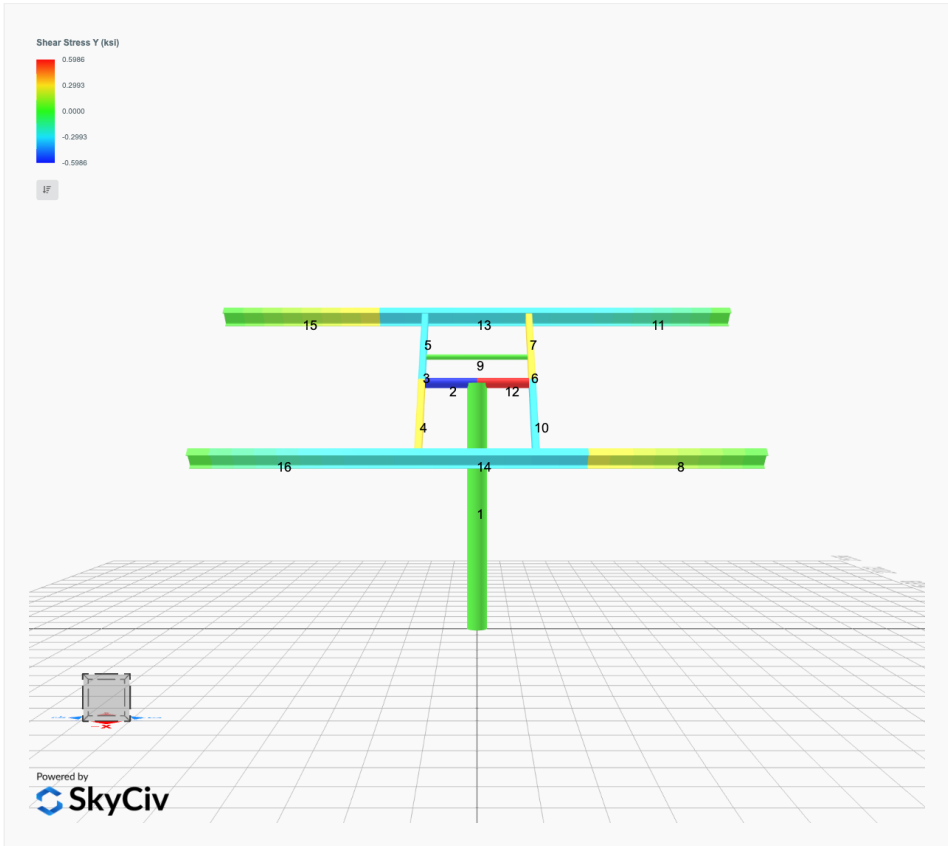
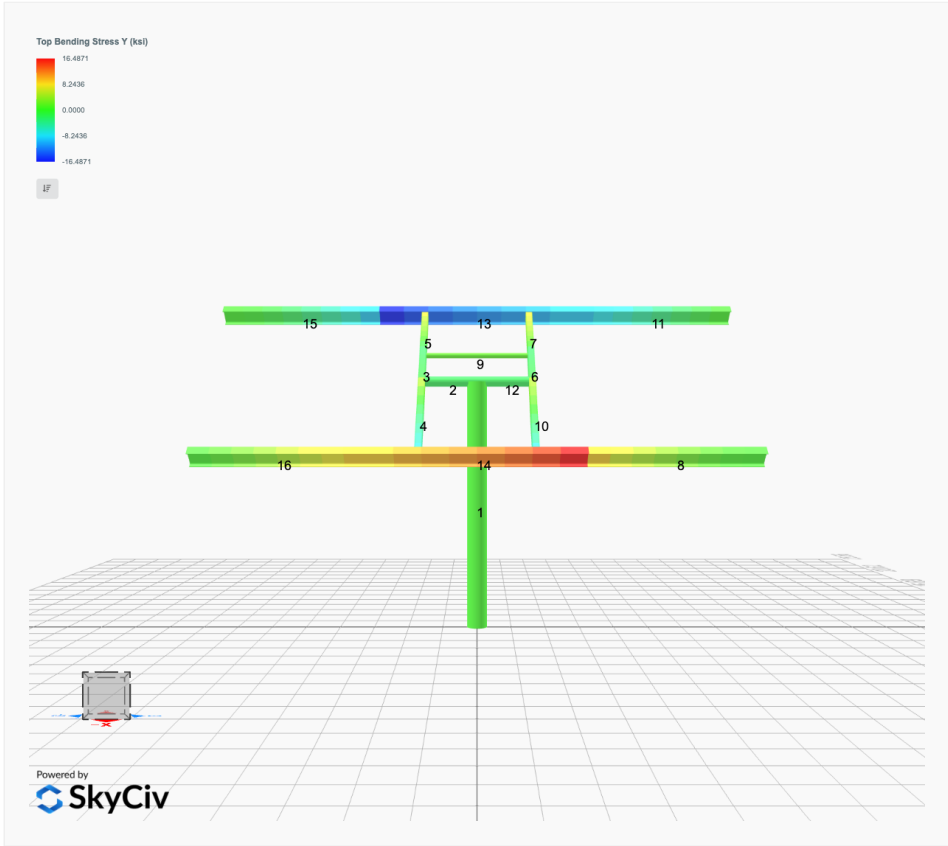

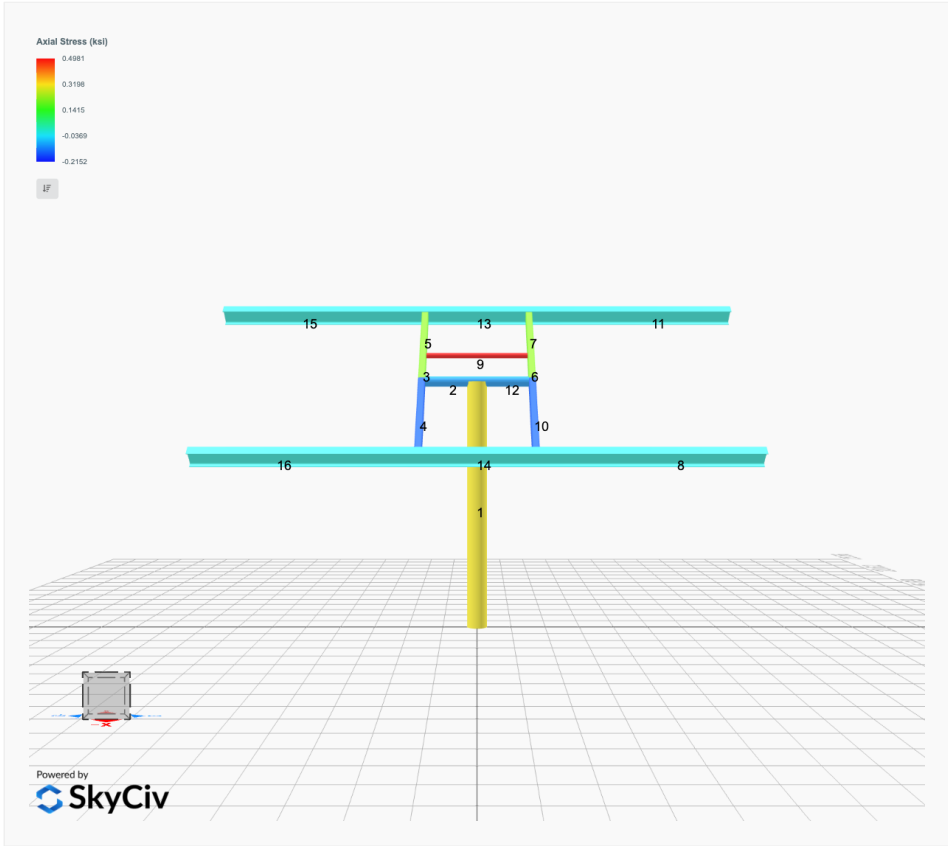

Reaction Forces for Foundation 1 (Node ID#1), (kip, kip-ft)

ASD Load Combination Results

Name	Fx	Fy	Fz	Mx	My	Mz
ULS: 1. D	0.0000	2.3702	0.0000	0.0000	-0.0000	0.0234
ULS: 2. D + L	0.0000	2.3702	0.0000	0.0000	-0.0000	0.0234
ULS: 3. D + (S or Lr or R)	0.0000	5.0472	0.0000	0.0000	-0.0000	0.0326
ULS: 3. D + (S or Lr or R)	0.0000	2.3702	0.0000	0.0000	-0.0000	0.0234
ULS: 4. D + 0.75L + 0.75(S or Lr or R)	0.0000	4.3780	0.0000	0.0000	-0.0000	0.0303
ULS: 4. D + 0.75L + 0.75(S or Lr or R)	0.0000	2.3702	0.0000	0.0000	-0.0000	0.0234
ULS: 5b. D + 0.7E	0.0000	2.3702	0.0000	0.0000	-0.0000	0.0234
ULS: 6b. D + 0.75L + 0.75(0.7)E + 0.75S	0.0000	4.3780	0.0000	0.0000	-0.0000	0.0303
ULS: 8. 0.6D + 0.7E	0.0000	1.4221	0.0000	0.0000	-0.0000	0.0140
ULS: 5a. D + 0.6W_Wind downforce Case A only	-3.4283	5.7985	-0.0000	0.0000	-0.0000	31.9811
ULS: 5a. D + 0.6W_Wind downforce Case B only	-3.4283	5.7985	-0.0000	0.0000	-0.0000	31.9811
ULS: 5a. D + 0.6W_Wind uplift Case A only	2.4801	-0.1099	0.0000	0.0000	-0.0000	-21.0846
ULS: 5a. D + 0.6W_Wind uplift Case B only	2.1883	0.1819	-0.0000	0.0000	-0.0000	-25.4221
ULS: 6a. D + 0.75L + 0.75(0.6)W + 0.75(S or Lr or R)_Wind downforce Case A only	-2.5712	6.9492	-0.0000	0.0000	-0.0000	23.9986
ULS: 6a. D + 0.75L + 0.75(0.6)W + 0.75(S or Lr or R)_Wind downforce Case B only	-2.5712	6.9492	-0.0000	0.0000	-0.0000	23.9986
ULS: 6a. D + 0.75L + 0.75(0.6)W + 0.75(S or Lr or R)_Wind uplift Case A only	1.8601	2.5179	0.0000	0.0000	-0.0000	-15.8007
ULS: 6a. D + 0.75L + 0.75(0.6)W + 0.75(S or Lr or R)_Wind uplift Case B only	1.6412	2.7368	-0.0000	0.0000	-0.0000	-19.0538
ULS: 6a. D + 0.75L + 0.75(0.6)W + 0.75(S or Lr or R)_Wind downforce Case A only	-2.5712	4.9415	-0.0000	0.0000	-0.0000	23.9917
ULS: 6a. D + 0.75L + 0.75(0.6)W + 0.75(S or Lr or R)_Wind downforce Case B only	-2.5712	4.9415	-0.0000	0.0000	-0.0000	23.9917
ULS: 6a. D + 0.75L + 0.75(0.6)W + 0.75(S or Lr or R)_Wind uplift Case A only	1.8601	0.5102	0.0000	0.0000	-0.0000	-15.8076
ULS: 6a. D + 0.75L + 0.75(0.6)W + 0.75(S or Lr or R)_Wind uplift Case B only	1.6412	0.7290	-0.0000	0.0000	-0.0000	-19.0607
ULS: 7. 0.6D + 0.6W_Wind downforce Case A only	-3.4283	4.8505	-0.0000	0.0000	-0.0000	31.9717
ULS: 7. 0.6D + 0.6W_Wind downforce Case B only	-3.4283	4.8505	-0.0000	0.0000	-0.0000	31.9717
ULS: 7. 0.6D + 0.6W_Wind uplift Case A only	2.4801	-1.0579	0.0000	0.0000	-0.0000	-21.0940
ULS: 7. 0.6D + 0.6W_Wind uplift Case B only	2.1883	-0.7662	-0.0000	0.0000	-0.0000	-25.4315

Worst Case Reactions LRFD

These calculations are taken directly from the FEA via SkyCiv and are used in the Concrete Checks of the Foundation Module.
Note: Worst case values are assumed as downforce wind load cases.

Result	Value
Axial	9.9844
Shear X	-5.7139
Shear Z	-0.0000
Moment X	-0.0000
Moment Z	53.7807

Worst Case Reactions ASD

These results are taken from the worst case values in the above table and are used in the Soil Checks in the Foundation Module.
Note: Worst case values are assumed as downforce wind load cases.

Result	Value
Axial	6.9492
Shear X	-3.4283
Shear Z	-0.0000
Moment X	0.0000
Moment Z	31.9811

Project Details

Design Code: AISC 360-16 LRFD
 Provision: LRFD
 Country: United States

User Name: sales@mtsolar.us
 Project Name: ChadLampson-RevB
 Unit System: imperial



Design Input Information

Design Factors			
Φ_t	Φ_c	Φ_b	Φ_v
0.9	0.9	0.9	0.9

Design Materials			
ID	E (ksi)	F _y (ksi)	F _u (ksi)
1	29000	50	65

Section Dimensions							

ID	Name	d (in)	t _w (in)				
2	2in Pipe Sch 80	2.38	0.22				
5	4in Pipe Sch 80	4.50	0.34				
9	8in Pipe Sch 40	8.63	0.32				

ID	Name	d (in)	b (in)	t _w (in)	t _b (in)	r (in)	
16	HSS5x3x3/16	5.00	3.00	0.17	0.17	0.17	

ID	Name	d (in)	t _w (in)	b _t (in)	b _b (in)	t _t (in)	t _b (in)	r (in)
19	W8x10	7.89	0.17	3.94	3.94	0.20	0.20	0.30

Section Properties								
ID	Name	A (in ²)	J (in ⁴)	I _{yp} (in ⁴)	I _{zp} (in ⁴)	I _w (in ⁶)	S _{yp} (in ³)	S _{zp} (in ³)
2	2in Pipe Sch 80	1.48	1.74	0.87	0.87	0.00	1.02	1.02
5	4in Pipe Sch 80	4.41	19.22	9.61	9.61	0.00	5.85	5.85

9	8in Pipe Sch 40	8.40	144.98	72.49	72.49	0.00	22.21	22.21
16	HSS5x3x3/16	2.58	8.64	3.85	8.53	92.39	2.96	4.21
19	W8x10	2.96	0.04	2.09	30.80	30.90	1.66	8.87

Member Properties								
Member ID	Section ID	K _z L (ft)	K _y L (ft)	L _b (ft)	C _b	LST	LSC	LD
1	9	18.66	18.66	8.89	-	300	200	1
2	5	1.30	1.30	2.00	-	300	200	1
3	16	0.92	0.92	1.42	1.19,1.18,1.19,1.18,1.18,1.19,1.18,1.18,1.17,1.18,1.18,1.18,1.17,1.18,1.18,1.18,1.20,1.18,1.18,1.17,1.18,1.18,1.18	300	200	1
4	16	2.44	2.44	3.75	1.68,1.68,1.68,1.67,1.68,1.68,1.67,1.67,1.66,1.86,1.67,1.67,1.66,1.63,1.67,1.67,1.68,1.68,1.67,1.67,1.65,1.73,1.67,1.67,1.66,1.65	300	200	1
5	16	1.52	1.52	2.33	1.68,1.67,1.68,1.67,1.67,1.68,1.67,1.67,1.66,1.66,1.67,1.67,1.66,1.66,1.67,1.67,1.69,1.67,1.67,1.65,1.66,1.67,1.67,1.66,1.66	300	200	1
6	16	0.92	0.92	1.42	1.19,1.18,1.19,1.18,1.18,1.19,1.18,1.18,1.17,1.18,1.18,1.18,1.17,1.18,1.18,1.18,1.20,1.18,1.18,1.17,1.18,1.18,1.18	300	200	1
7	16	1.52	1.52	2.33	1.68,1.67,1.68,1.67,1.67,1.68,1.67,1.67,1.66,1.66,1.67,1.67,1.66,1.66,1.67,1.67,1.69,1.67,1.67,1.65,1.66,1.67,1.67,1.66,1.66	300	200	1
8	19	12.60	12.60	6.00	2.33,2.33	300	200	1
9	2	2.60	2.60	4.00	-	300	200	1
10	16	2.44	2.44	3.75	1.68,1.68,1.68,1.67,1.68,1.68,1.67,1.67,1.66,1.86,1.67,1.67,1.66,1.63,1.67,1.67,1.68,1.68,1.67,1.67,1.65,1.73,1.67,1.67,1.66,1.65	300	200	1
11	19	12.60	12.60	6.00	2.33,2.33	300	200	1
12	5	1.30	1.30	2.00	-	300	200	1
13	19	1.14	1.14	1.75	1.20,1.20	300	200	1
14	19	1.14	1.14	1.75	1.20,1.20	300	200	1
15	19	12.60	12.60	6.00	2.33,2.33	300	200	1
16	19	12.60	12.60	6.00	2.33,2.33	300	200	1
17	19	2.60	2.60	4.00	1.05,1.05	300	200	1
18	19	1.14	1.14	1.75	1.20,1.20	300	200	1
19	19	2.60	2.60	4.00	1.04,1.05,1.04,1.05,1.05,1.04,1.04,1.04,1.05,1.01,1.05,1.05,1.05,1.03,1.04,1.04,1.04,1.05,1.05,1.05,1.05,1.06,1.05,1.05,1.05,1.04	300	200	1
20	19	1.14	1.14	1.75	1.20,1.20	300	200	1

Member Design Capacity

Member ID	Φ _t P _n (kip)	Φ _c P _n (kip)	Φ _b M _{zn} (k-ft)	Φ _b M _{yn} (k-ft)	Φ _v V _{yn} (kip)	Φ _v V _{zn} (kip)
1	377.97	247.17	83.29	83.29	113.39	113.39

2	198.33	196.72	21.95	21.95	59.50	59.50
3	116.10	115.41	15.79	11.10	42.08	23.28
4	116.10	111.33	15.79	11.10	42.08	23.28
5	116.10	114.23	15.79	11.10	42.08	23.28
6	116.10	115.41	15.79	11.10	42.08	23.28
7	116.10	114.23	15.79	11.10	42.08	23.28
8	133.20	20.65	32.87	6.12	40.24	43.62
9	66.48	58.89	3.82	3.82	19.94	19.94
10	116.10	111.33	15.79	11.10	42.08	23.28
11	133.20	20.65	32.87	6.12	40.24	43.62
12	198.33	196.72	21.95	21.95	59.50	59.50
13	133.20	126.79	32.87	6.12	40.24	43.62
14	133.20	126.79	32.87	6.12	40.24	43.62
15	133.20	20.65	32.87	6.12	40.24	43.62
16	133.20	20.65	32.87	6.12	40.24	43.62
17	133.20	118.19	32.14	6.12	40.24	43.62
18	133.20	126.79	32.87	6.12	40.24	43.62
19	133.20	118.19	31.22	6.12	40.24	43.62
20	133.20	126.79	32.87	6.12	40.24	43.62

Design Ratio

Member ID	P	M _z	M _y	V _y	V _z	(P,M _z ,M _y)	Worst LC	KL/r	δ	Status
1	0.040	0.646	0.000	0.050	0.000	0.666	#13	0.381	Not Required	Pass
2	0.007	0.369	0.267	0.081	0.048	0.638	#13	0.035	Not Required	Pass
3	0.010	0.671	0.064	0.067	0.009	0.695	#13	0.045	Not Required	Pass
4	0.010	0.606	0.248	0.061	0.050	0.690	#13	0.080	Not Required	Pass
5	0.010	0.416	0.259	0.067	0.067	0.457	#13	0.074	Not Required	Pass
6	0.010	0.671	0.064	0.067	0.009	0.695	#13	0.045	Not Required	Pass
7	0.010	0.416	0.259	0.067	0.067	0.457	#13	0.074	Not Required	Pass
8	0.000	0.142	0.350	0.039	0.016	0.469	#21	Not Required	Not Required	Pass
9	0.030	0.053	0.063	0.001	0.000	0.123	#13	0.204	Not Required	Pass
10	0.010	0.606	0.248	0.061	0.050	0.690	#13	0.080	Not Required	Pass
11	0.000	0.157	0.350	0.043	0.016	0.476	#21	Not Required	Not Required	Pass
12	0.007	0.369	0.267	0.081	0.048	0.638	#13	0.035	Not Required	Pass
13	0.000	0.261	0.584	0.055	0.021	0.794	#21	Not Required	Not Required	Pass
14	0.000	0.237	0.584	0.050	0.021	0.782	#21	Not Required	Not Required	Pass
15	0.000	0.157	0.350	0.043	0.016	0.476	#21	Not Required	Not Required	Pass
16	0.000	0.142	0.350	0.039	0.016	0.469	#21	Not Required	Not Required	Pass
17	0.012	0.272	0.114	0.014	0.005	0.338	#21	0.124	Not Required	Pass
18	0.000	0.261	0.584	0.055	0.021	0.794	#21	Not Required	Not Required	Pass
19	0.010	0.255	0.134	0.013	0.005	0.350	#21	0.186	Not Required	Pass
20	0.000	0.237	0.584	0.050	0.021	0.782	#21	Not Required	Not Required	Pass

Definitions

Φ _t	Safety factor for tensile
Φ _c	Safety factor for compression
Φ _b	Safety factor for flexure
Φ _v	Safety factor for shear
E	Modulus of elasticity
F _y	Specified minimum yield stress
F _u	Specified minimum tensile strength
A	Cross-sectional area
I	Torsional constant

J	Torsional constant
I_{yp}	Moment of inertia about the Y axes
I_{zp}	Moment of inertia about the Z axes
I_w	Warping constant
S_{yp}	Plastic section modulus about the Y axis
S_{zp}	Plastic section modulus about the Z axis
KL	Effective length
C_b	Buckling modification factor (from all load combinations)
L_b	Length between braced points
LST	Limited slenderness for tension
LSC	Limited slenderness for compression
LD	Limited deflection
P_n	Nominal axial strength (tension/compression)
M_n	Nominal flexural strength (about Z/Y axis)
V_n	Nominal shear strength (along Z/Y axis)
P	Design ratio in case of axial force
M_z	Design ratio in case of bending about Z axis
M_y	Design ratio in case of bending about Y axis
V_y	Design ratio in case of shear along Y axis
V_z	Design ratio in case of shear along Z axis
(P, M_z , M_y)	Design ratio in case of axial force and bending action
KL/r	Design ratio in case of section slenderness
δ	Design ratio in case of member deflection
OK	Capacity is provided
NG	Capacity is not provided

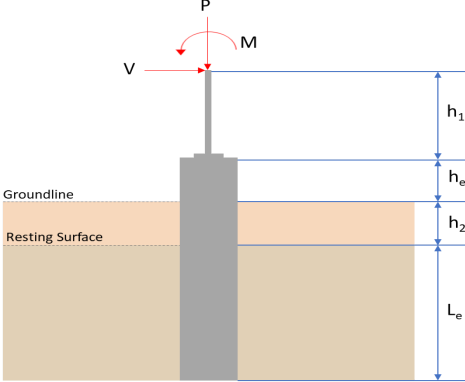
REFERENCES	CALCULATIONS	RESULTS																										
	<p>SkyCiv Foundation Design Pile Foundation</p> <p>Design Information : Design code : IBC 2021 (International Building Code) Unit System : Imperial</p>																											
	<p>Pile Input</p>  <p>Geometry Pile shape: round $D = 36$ in - Pile diameter $L = 9$ ft - Total pile length $h_1 = 0$ ft - Lateral load height from the top of the pile, $h_2 = 0$ ft - Depth to resisting surface $h_e = 0$ ft - Length of pile above the ground</p> <p>Tabulation of Soil Parameters</p> <table border="1" data-bbox="416 1079 1193 1171"> <thead> <tr> <th>Layer</th> <th>Label</th> <th>Allowable Bearing Pressure (q_a) (psf)</th> <th>Allowable Lateral Pressure (R) (psf/ft)</th> </tr> </thead> <tbody> <tr> <td>1</td> <td>Sand, silty sand, clayey sand, silty gravel & clayey gravel</td> <td>2000.000</td> <td>150.000</td> </tr> </tbody> </table> <p>Tabulation of Loads</p> <table border="1" data-bbox="676 1265 935 1435"> <thead> <tr> <th>Load Component</th> <th>ASD</th> <th>LRFD</th> </tr> </thead> <tbody> <tr> <td>P (kip)</td> <td>6.949</td> <td>9.984</td> </tr> <tr> <td>V_x (kip)</td> <td>-3.428</td> <td>-5.714</td> </tr> <tr> <td>V_z (kip)</td> <td>0.000</td> <td>0.000</td> </tr> <tr> <td>M_x (kipft)</td> <td>0.000</td> <td>0.000</td> </tr> <tr> <td>M_z (kipft)</td> <td>31.981</td> <td>53.781</td> </tr> </tbody> </table> <p>Material Properties $f'_{ck} = 3$ ksi - Concrete strength,</p>	Layer	Label	Allowable Bearing Pressure (q_a) (psf)	Allowable Lateral Pressure (R) (psf/ft)	1	Sand, silty sand, clayey sand, silty gravel & clayey gravel	2000.000	150.000	Load Component	ASD	LRFD	P (kip)	6.949	9.984	V_x (kip)	-3.428	-5.714	V_z (kip)	0.000	0.000	M_x (kipft)	0.000	0.000	M_z (kipft)	31.981	53.781	
Layer	Label	Allowable Bearing Pressure (q_a) (psf)	Allowable Lateral Pressure (R) (psf/ft)																									
1	Sand, silty sand, clayey sand, silty gravel & clayey gravel	2000.000	150.000																									
Load Component	ASD	LRFD																										
P (kip)	6.949	9.984																										
V_x (kip)	-3.428	-5.714																										
V_z (kip)	0.000	0.000																										
M_x (kipft)	0.000	0.000																										
M_z (kipft)	31.981	53.781																										
	<p>Required depth to resist lateral loads (ASD) H - Point of application of the lateral load</p> $H = h_1 + h_2 + h_e$ $H = (0 \text{ ft}) + (0 \text{ ft}) + (0 \text{ ft})$ $H = 0 \text{ ft}$ <p>Considering x-direction: H_o - Lateral force per length of pile,</p> $H_o = \frac{V_x}{D}$ $H_o = \frac{(-3.428 \text{ kip})}{(36 \text{ in})}$ $H_o = -1.1427 \text{ kip/ft}$ <p>M_o - Moment per length of pile,</p> $M_o = \frac{M_z + (V_x H)}{D}$																											

	$M_o = \frac{(31.981 \text{ kipft}) + ((-3.428 \text{ kip}) \times (0 \text{ ft}))}{(36 \text{ in})}$ $M_o = 10.66 \text{ kipft/ft}$ <p>Required depth of embedment in earth:</p> $L_x^3 - \left(14.14 \times \frac{H_o \times L_x}{R}\right) - \left(18.85 \times \frac{M_o}{R}\right) = 0$ <p>Solving the cubic equation: $L_{e,x} = 7.8853 \text{ ft}$ - Required depth in x-direction,</p> <p>Considering z-direction: $L_{e,z} = 0 \text{ ft}$ - Required depth in z-direction,</p> <p>Minimum embedded depth required: $L_{e,req}$ - Depth of pile required,</p> $L_{e,req} = \text{MAX}[L_{e,x}, L_{e,z}]$ $L_{e,req} = \text{MAX}[(7.8853 \text{ ft}), (0 \text{ ft})]$ $L_{e,req} = 7.885 \text{ ft}$ <p>L_e - Actual embedded length of pile,</p> $L_e = L - h_c - h_2$ $L_e = (9 \text{ ft}) - (0 \text{ ft}) - (0 \text{ ft})$ $L_e = 9 \text{ ft}$ <p>Ratio - Embedded depth</p> $\text{Ratio} = \frac{L_{e,req}}{L_e}$ $\text{Ratio} = \frac{(7.885 \text{ ft})}{(9 \text{ ft})}$ $\text{Ratio} = 0.87611$	<p>Status: PASS Ratio: 0.880</p>
	<p>End-bearing Capacity (ASD)</p> <p>A - Pile cross-section area</p> $A = \pi \left(\frac{D}{2}\right)^2$ $A = \pi \times \left(\frac{(36 \text{ in})}{2}\right)^2$ $A = 7.0686 \text{ ft}^2$ <p>q - End-bearing pressure</p> $q = \frac{P_c}{A}$ $q = \frac{(6.949 \text{ kip})}{(7.0686 \text{ ft}^2)}$ $q = 0.98308 \text{ kip/ft}^2$ <p>Check bearing capacity ratio:</p> <p>Ratio - Capacity</p> $\text{Ratio} = \frac{q}{q_a}$ $\text{Ratio} = \frac{(0.98308 \text{ kip/ft}^2)}{(2000 \text{ psf})}$ $\text{Ratio} = 0.49154$	<p>Status: PASS Ratio: 0.490</p>
Czerniak	<p>Lateral Soil Pressure (ASD):</p> <p>L/D - Length to least lateral dimension ratio,</p> $L/D = \frac{L}{D}$ $L/D = \frac{(9 \text{ ft})}{(36 \text{ in})}$	

$$L/D = 3$$

Since $L/D \leq 10$,

Pile is short.

Considering x-direction:

$H_o = -1.1427$ kip/ft - Lateral force per length of pile,

$M_o = 10.66$ kipft/ft - Overturning moment per length of pile,

a - Distance from resting surface to pivot point,

$$a = \frac{(4 M_o L_e) + (3 H_o L_e^2)}{(6 M_o) + (4 H_o L_e)}$$

$$a = \frac{(4 \times (10.66 \text{ kipft/ft}) \times (9 \text{ ft})) + (3 \times (-1.1427 \text{ kip/ft}) \times (9 \text{ ft})^2)}{(6 \times (10.66 \text{ kipft/ft})) + (4 \times (-1.1427 \text{ kip/ft}) \times (9 \text{ ft}))}$$

$$a = 6.2936 \text{ ft}$$

p - Earth pressure against the pile at distance $a/2$ from resting surface,

$$p = \frac{1.178 [(4 M_o) + (3 H_o L_e)]^2}{L_e^2 [(3 M_o) + (2 H_o L_e)]}$$

$$p = \frac{1.178 \times [(4 \times (10.66 \text{ kipft/ft})) + (3 \times (-1.1427 \text{ kip/ft}) \times (9 \text{ ft}))]^2}{(9 \text{ ft})^2 \times [(3 \times (10.66 \text{ kipft/ft})) + (2 \times (-1.1427 \text{ kip/ft}) \times (9 \text{ ft}))]}$$

$$p = 0.17711 \text{ kip/ft}^2$$

s - Earth pressure against the pile at distance L_e ,

$$s = \frac{9.425 [(2 M_o) + (H_o L_e)]}{L_e^2}$$

$$s = \frac{9.425 \times [(2 \times (10.66 \text{ kipft/ft})) + ((-1.1427 \text{ kip/ft}) \times (9 \text{ ft}))]}{(9 \text{ ft})^2}$$

$$s = 1.2842 \text{ kip/ft}^2$$

Check lateral soil pressure capacity:

p_a - Allowable lateral soil pressure at depth $a/2$,

$$p_a = R \frac{a}{2}$$

$$p_a = (150 \text{ psf/ft}) \times \frac{(6.2936 \text{ ft})}{2}$$

$$p_a = 0.47202 \text{ kip/ft}^2$$

Ratio - Lateral soil capacity

$$\text{Ratio} = \frac{p}{p_a}$$

$$\text{Ratio} = \frac{(0.17711 \text{ kip/ft}^2)}{(0.47202 \text{ kip/ft}^2)}$$

$$\text{Ratio} = 0.37522$$

p_s - Allowable lateral soil pressure at depth L_e ,

$$p_s = R L_e$$

$$p_s = (150 \text{ psf/ft}) \times (9 \text{ ft})$$

$$p_s = 1.35 \text{ kip/ft}^2$$

Ratio - Lateral soil capacity

$$\text{Ratio} = \frac{s}{p_s}$$

$$\text{Ratio} = \frac{(1.2842 \text{ kip/ft}^2)}{(1.35 \text{ kip/ft}^2)}$$

$$\text{Ratio} = 0.95126$$

Status: **PASS**
Ratio: **0.380**

Status: **PASS**
Ratio: **0.950**

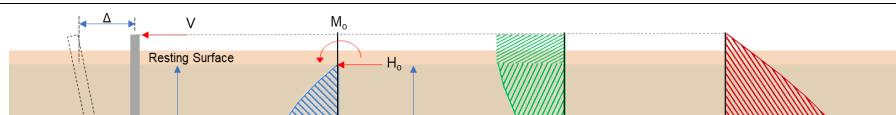

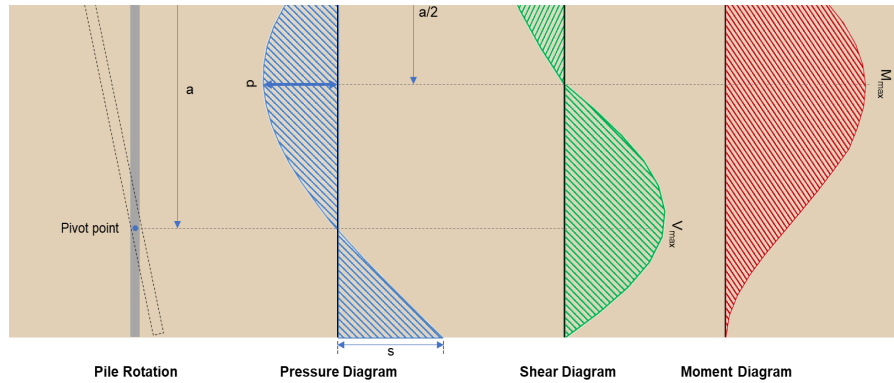

Shear force and Bending moment (x-direction, LRFD)

H_o - Lateral force per length of pile,

$$H_o = \frac{V_x}{D}$$

$$H_o = \frac{(-5.714 \text{ kip})}{(36 \text{ in})}$$

$$H_o = -1.9047 \text{ kip/ft}$$

M_o - Moment per length of pile,

$$M_o = \frac{M_x + (V_x H)}{D}$$

$$M_o = \frac{(53.781 \text{ kipft}) + ((-5.714 \text{ kip}) \times (0 \text{ ft}))}{(36 \text{ in})}$$

$$M_o = 17.927 \text{ kipft/ft}$$

E - Distance from lateral load to resisting surface,

$$E = \frac{M_o}{H_o}$$

$$E = \frac{(17.927 \text{ kipft/ft})}{(-1.9047 \text{ kip/ft})}$$

$$E = 9.4121 \text{ ft}$$

a - Distance from resting surface to pivot point,

$$a = \frac{(4 M_o L_c) + (3 H_o L_c^2)}{(6 M_o) + (4 H_o L_c)}$$

$$a = \frac{(4 \times (17.927 \text{ kipft/ft}) \times (9 \text{ ft})) + (3 \times (-1.9047 \text{ kip/ft}) \times (9 \text{ ft})^2)}{(6 \times (17.927 \text{ kipft/ft})) + (4 \times (-1.9047 \text{ kip/ft}) \times (9 \text{ ft}))}$$

$$a = 6.292 \text{ ft}$$

V_{max} - Max shear force located at depth a ,

$$V_{max} = (H_o D) \left[1 - \left[3 \left(\frac{4 E}{L_c} + 3 \right) \left(\frac{a}{L_c} \right)^2 \right] + \left[4 \left(\frac{3 E}{L_c} + 2 \right) \left(\frac{a}{L_c} \right)^3 \right] \right]$$

$$V_{max} = ((-1.9047 \text{ kip/ft}) \times (36 \text{ in})) \times \left[1 - \left[3 \times \left(\frac{4 \times (9.4121 \text{ ft})}{(9 \text{ ft})} + 3 \right) \times \left(\frac{(6.292 \text{ ft})}{(9 \text{ ft})} \right)^2 \right] + \left[4 \times \left(\frac{3 \times (9.4121 \text{ ft})}{(9 \text{ ft})} + 2 \right) \times \left(\frac{(6.292 \text{ ft})}{(9 \text{ ft})} \right)^3 \right] \right]$$

$$V_{max} = 14.347 \text{ kip}$$

M_{max} - Max bending moment located at depth $a/2$,

$$M_{max} = (H_o D L_c) \left[\left(\frac{E}{L_c} + \frac{a}{2 L_c} \right) - \left[\left(\frac{4 E}{L_c} + 3 \right) \left(\frac{a}{2 L_c} \right)^3 \right] + \left[\left(\frac{3 E}{L_c} + 2 \right) \left(\frac{a}{2 L_c} \right)^4 \right] \right]$$

$$M_{max} = ((-1.9047 \text{ kip/ft}) \times (36 \text{ in}) \times (9 \text{ ft})) \times \left[\left(\frac{(9.4121 \text{ ft})}{(9 \text{ ft})} + \frac{(6.292 \text{ ft})}{2 \times (9 \text{ ft})} \right) - \left[\left(\frac{4 \times (9.4121 \text{ ft})}{(9 \text{ ft})} + 3 \right) \times \left(\frac{(6.292 \text{ ft})}{2 \times (9 \text{ ft})} \right)^3 \right] + \left[\left(\frac{3 \times (9.4121 \text{ ft})}{(9 \text{ ft})} + 2 \right) \times \left(\frac{(6.292 \text{ ft})}{2 \times (9 \text{ ft})} \right)^4 \right] \right]$$

$$M_{max} = 59.924 \text{ kipft}$$

Minimum Reinforcement Check (LRFD)

Parameters:

$f'_{ck} = 3 \text{ ksi}$ - Concrete strength,
 $f_{yk} = 60 \text{ ksi}$ - Longitudinal reinforcement strength,
 $\phi = 0.65$ - Reduction factor for axial strength,
 $\alpha = 0.85$ - Alpha factor for axial strength,
 $A_g = 1017.9 \text{ in}^2$ - Gross area of concrete,

Table 22.4.2.1

Longitudinal reinforcement:

Required reinforcement due to axial load, $A_{st,required}$

22.4.2.2, 10.6.1.1

$A_{st,required}$

$$A_{st,required} = \text{Min} \left[\frac{\frac{P}{\phi \alpha} - (0.85 f'_{ck} A_g)}{f_{yk} - (0.85 f'_{ck})}, (0.08 A_g) \right]$$

$$A_{st,required} = \text{Min} \left[\frac{\frac{(9.984 \text{ kip})}{(0.65) \times (0.85)} - (0.85 \times (3 \text{ ksi}) \times (1017.9 \text{ in}^2))}{(60 \text{ ksi}) - (0.85 \times (3 \text{ ksi}))}, (0.08 \times (1017.9 \text{ in}^2)) \right]$$

$$A_{st,required} = -44.865 \text{ in}^2$$

A_{min} - Governing minimum reinforcement area,

$$A_{min} = \text{Max} [A_{st,required}, (0.0018 A_g)]$$

$$A_{min} = \text{Max} [(-44.865 \text{ in}^2), (0.0018 \times (1017.9 \text{ in}^2))]$$

$$A_{min} = 1.8322 \text{ in}^2$$

n_{rebar} - Required number of reinforcement,

$$n_{rebar} = \frac{A_{min}}{A_{rebar}}$$

$$n_{rebar} = \frac{(1.8322 \text{ in}^2)}{(0.3068 \text{ in}^2)}$$

$$n_{rebar} = 6$$

A_{st} - Actual total reinforcement area,

$$A_{st} = n_{rebar} \frac{\pi d_{bar}^2}{4}$$

$$A_{st} = (6) \times \frac{\pi \times (0.625 \text{ in})^2}{4}$$

$$A_{st} = 1.8408 \text{ in}^2$$

Ratio - Capacity

$$\text{Ratio} = \frac{A_{min}}{A_{st}}$$

$$\text{Ratio} = \frac{(1.8322 \text{ in}^2)}{(1.8408 \text{ in}^2)}$$

$$\text{Ratio} = 0.99533$$

25.2.3

s_{rebar} - Minimum spacing of reinforcement,

$$s_{rebar} = \text{Max} [1.5, (1.5 d_{bar})]$$

$$s_{rebar} = \text{Max} [1.5, (1.5 \times (0.625 \text{ in}))]$$

$$s_{rebar} = 1.5 \text{ in}$$

Ties:

25.7.2.2

Since longitudinal reinforcement is \leq No. 10Ø: Use #3(0.375 in)

25.7.2.1

s_{ties} - Maximum center-to-center spacing of ties,

$$s_{ties} = \text{Min} [(16 d_{bar}), (48 d_{ties}), D]$$

$$s_{ties} = \text{Min} [(16 \times (0.625 \text{ in})), (48 \times (0.375 \text{ in})), (36 \text{ in})]$$

$$s_{ties} = 10 \text{ in}$$

Summary:

Status: **PASS**
Ratio: **1.000**

Main reinforcement: **6 - #5 (0.625 in)**
Ties: **#3(0.375 in) - 10 in**

Axial Compression Strength (ACI 318-19, LRFD)

22.4.2.2 ϕP_N - Allowable axial compressive strength

$$\phi P_N = \phi \cdot 0.85 \left[(0.85 f'_{ck} [A_g - A_{st}]) + (f_{yk} A_{st}) \right]$$

$$\phi P_N = (0.65) \times 0.85 \times \left[(0.85 \times (3 \text{ ksi}) \times [(1017.9 \text{ in}^2) - (1.8408 \text{ in}^2)]) + ((60 \text{ ksi}) \times (1.8408 \text{ in}^2)) \right]$$

$$\phi P_N = 1492.5 \text{ kip}$$

Ratio - Capacity

$$\text{Ratio} = \frac{P}{\phi P_N}$$

$$\text{Ratio} = \frac{(9.984 \text{ kip})}{(1492.5 \text{ kip})}$$

$$\text{Ratio} = 0.0066895$$

Status: **PASS**
Ratio: **0.010**

Shear Strength (ACI 318-19, LRFD)

Parameters:

$b_w = 36 \text{ in}$ - Effective width,

22.5.2.2 d - Effective depth

$$d = 0.80 D$$

$$d = 0.80 \times (36 \text{ in})$$

$$d = 28.8 \text{ in}$$

22.5.5.1.3 λ_s - size effect modification factor

$$\lambda_s = \text{MIN} \left[\sqrt{\frac{2}{1 + \frac{d}{10}}}, 1 \right]$$

$$\lambda_s = \text{MIN} \left[\sqrt{\frac{2}{1 + \frac{(28.8 \text{ in})}{10}}}, 1 \right]$$

$$\lambda_s = 0.71796$$

The following variables were converted to be consistent with empirical formula $f'_{ck} = 3 \text{ ksi} \rightarrow 3000 \text{ psi}$.

22.5.5.1.1 $V_{c,max}$ - Max shear strength of concrete

$$V_{c,max} = 5 \lambda_s \sqrt{f'_{ck}} b_w d$$

$$V_{c,max} = 5 \times (0.71796) \times \sqrt{(3000 \text{ psi})} \times (36 \text{ in}) \times (28.8 \text{ in})$$

$$V_{c,max} = 203.86 \text{ kip}$$

The following variables were converted to be consistent with empirical formula $f'_{ck} = 3 \text{ ksi} \rightarrow 3000 \text{ psi}$, $P = 9.984 \text{ kip} \rightarrow 9984 \text{ lbf}$.

22.5.5.1.1(a) $V_{c,a}$ - Shear strength of concrete (a)

$$V_{c,a} = \left[2 \lambda_s \sqrt{f'_{ck}} + \frac{P}{6 A_g} \right] b_w d$$

$$V_{c,a} = \left[2 \times (0.71796) \times \sqrt{(3000 \text{ psi})} + \frac{(9984 \text{ lbf})}{6 \times (1017.9 \text{ in}^2)} \right] \times (36 \text{ in}) \times (28.8 \text{ in})$$

$$V_{c,a} = 83.238 \text{ kip}$$

The following variables were converted to be consistent with empirical formula $f'_{ck} = 3 \text{ ksi} \rightarrow 3000 \text{ psi}$,

22.5.5.1.2 $V_{c,b}$ - Shear strength of concrete (b)

$$V_{c,b} = \left[2 \lambda_s \sqrt{f'_{ck}} + (0.05 f'_{ck}) \right] b_w d$$

$$V_{c,b} = \left[2 \times (0.71796) \times \sqrt{(3000 \text{ psi})} + (0.05 \times (3000 \text{ psi})) \right] \times (36 \text{ in}) \times (28.8 \text{ in})$$

$$V_{c,b} = 237.06 \text{ kip}$$

V_c - Governing shear strength of concrete

$$V_c = \text{Min} [V_{c,max}, V_{c,a}, V_{c,b}]$$

$$V_c = \text{Min} [(203.86 \text{ kip}), (83.238 \text{ kip}), (237.06 \text{ kip})]$$

<p>22.5.1.2</p> <p>22.5.8.5.3</p> <p>22.5.1.1</p>	<p style="text-align: center;">$V_c = 83.238 \text{ kip}$</p> <p>The following variables were converted to be consistent with empirical formula $f'_{ck} = 3 \text{ ksi} \rightarrow 3000 \text{ psi}$.</p> <p>$V_{s,a}$ - Shear strength of steel (a)</p> $V_{s,a} = 8 \sqrt{f'_{ck}} b_w d$ $V_{s,a} = 8 \times \sqrt{(3000 \text{ psi})} \times (36 \text{ in}) \times (28.8 \text{ in})$ $V_{s,a} = 454.3 \text{ kip}$ <p>A_v - Ties rebar area,</p> $A_v = \frac{\pi d_{ties}^2}{4}$ $A_v = \frac{\pi \times (0.375 \text{ in})^2}{4}$ $A_v = 0.11045 \text{ in}^2$ <p>$V_{s,b}$ - Shear strength of steel (b)</p> $V_{s,b} = \frac{2 A_v f_{yw} d}{s_{ties}}$ $V_{s,b} = \frac{2 \times (0.11045 \text{ in}^2) \times (60 \text{ ksi}) \times (28.8 \text{ in})}{(10 \text{ in})}$ $V_{s,b} = 38.17 \text{ kip}$ <p>V_s - Governing shear strength of steel</p> $V_s = \text{MIN}[V_{s,a}, V_{s,b}]$ $V_s = \text{MIN}[(454.3 \text{ kip}), (38.17 \text{ kip})]$ $V_s = 38.17 \text{ kip}$ <p>ϕV_n - Allowable shear strength</p> $\phi V_n = \phi (V_c + V_s)$ $\phi V_n = (0.65) \times ((83.238 \text{ kip}) + (38.17 \text{ kip}))$ $\phi V_n = 78.915 \text{ kip}$ <p>Considering x-direction:</p> <p>$V_{max} = 14.347 \text{ kip}$ - Maximum shear force in the x-direction, <i>Ratio</i> - Capacity</p> $\text{Ratio} = \frac{V_{max}}{\phi V_n}$ $\text{Ratio} = \frac{(14.347 \text{ kip})}{(78.915 \text{ kip})}$ $\text{Ratio} = 0.1818$	<p>Status: PASS Ratio: 0.180</p>
<p>14.5.2.1b</p>	<p>Flexural Strength (ACI 318-19, LFRD)</p> <p>S_m - Section modulus</p> $S_m = \frac{\pi D^3}{32}$ $S_m = \frac{\pi \times (36 \text{ in})^3}{32}$ $S_m = 4580.4 \text{ in}^3$ <p>$\lambda = 1$ - Concrete modification factor (Normal concrete), Allowable flexural strength: M_n shall be the lesser of:</p> <p>$\phi M_{n,1}$</p> $\phi M_{n,1} = \phi \times 5 \times \lambda \times \sqrt{f'_c} \times S_m$ $\phi M_{n,1} = 0.65 \times 5 \times 1 \times \sqrt{(3 \text{ ksi})} \times 4580.442 \text{ in}^3$ $\phi M_{n,1} = 67.947 \text{ kipft}$ <p>$\phi M_{n,2}$</p>	

$$\phi M_{n,2} = \phi 0.85 f'_{ck} S_m$$

$$\phi M_{n,2} = (0.65) \times 0.85 \times (3 \text{ ksi}) \times (4580.4 \text{ in}^3)$$

$$\phi M_{n,2} = 632.67 \text{ kipft}$$

Therefore,

ϕM_n - Allowable flexural strength,

$$\phi M_n = \text{MIN}[\phi M_{n,1}, \phi M_{n,2}]$$

$$\phi M_n = \text{MIN}[(67.947 \text{ kipft}), (632.67 \text{ kipft})]$$

$$\phi M_n = 67.947 \text{ kipft}$$

Considering x-direction:

$M_{max} = 59.924 \text{ kipft}$ - Maximum moment in the x-direction,

Ratio - Capacity

$$\text{Ratio} = \frac{M_{max}}{\phi M_n}$$

$$\text{Ratio} = \frac{(59.924 \text{ kipft})}{(67.947 \text{ kipft})}$$

$$\text{Ratio} = 0.88192$$

Status: **PASS**
Ratio: **0.880**