

Project Name: Wayman-v4CU

Date: Wed Aug 20 2025

Location: XCMQ+2J2, Animas Forks, CO 81433,
USA

Number of Modules: 10

Unique ID: 1P-0-8TOP-HD-24-L-5Hx2W-7L6I

Number of Poles: 1

Dealer: _____

Date Sold:

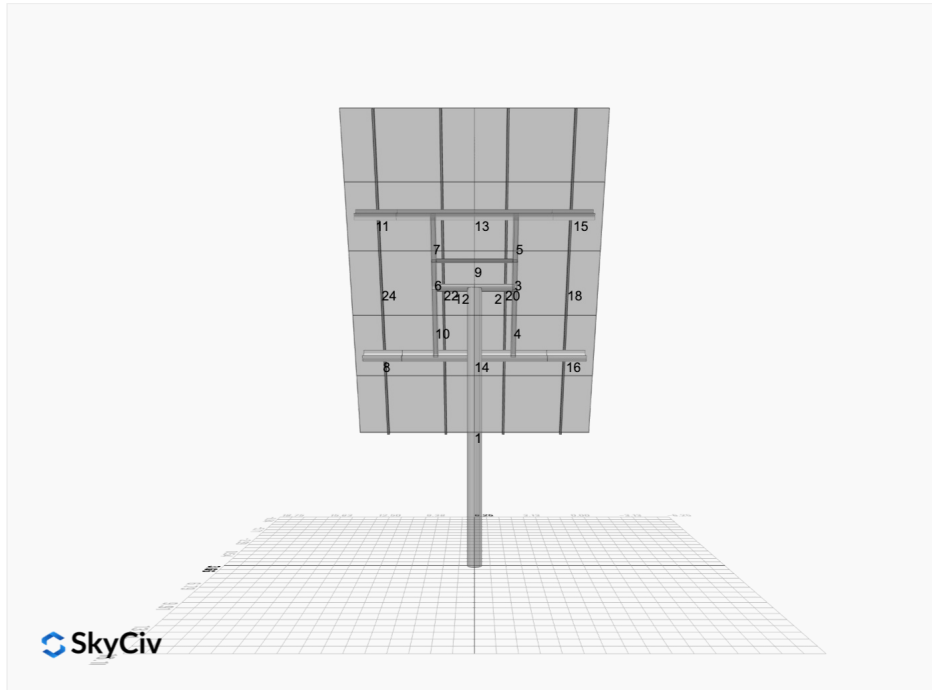

| | |
|-----------------------------|----------|
| Array Dimensions N/S | 17.33 ft |
| Array Dimensions E/W | 12.50 ft |
| Winter Tilt Angle | 65 |
| Front Edge Clearance | 6 ft |

MT Solar Bill of Materials (1P-0-8TOP-HD-24-L-5Hx2W-7L6I)

| Part | Short Description | BOM Qty |
|---------------------|-----------------------|---------|
| MTS-PC-8 | 8IN Pole Cap Assembly | 1 |
| MTS-HF-HD | H-Frame Assembly-HD | 1 |
| MTS-HD-Wing-24 | 24IN HD Wing | 4 |
| MTS-CLAMP-ANGLE-4PK | Angle Clamp | 2 |

Rail Bill of Materials

| Part | Qty |
|------------------|-----|
| Rails (208in) | 4 |
| Rail Attachment | 16 |
| Module Mid Clamp | 16 |
| Module End Clamp | 8 |
| Ground Lug | 2 |

Site Details:



Site Address: XCMQ+2J2, Animas Forks, CO 81433, USA

Array Specification

| | |
|------------------------------------|-----------|
| Duty Classification: | HD |
| Module Width: | 41.10 in |
| Module Length: | 74.00in |
| Number of Rows: | 5 |
| Number of Columns: | 2 |
| Total Number of Modules: | 10 |
| Winter Tilt Angle: | 65 |
| Front Edge Clearance: | 6 |
| Total Array Height at Tilt: | 21.71 ft |
| Total Frame Length: | 11.50 ft |
| Module Info/Notes: | |
| Array Dimensions N/S: | 17.33 ft |
| Array Dimensions E/W: | 12.50 ft |
| Rail Length: | 208.00 in |
| Rail Spacing: | 3.13 ft |

Support Specifications

| | |
|---------------------------------|-----------------|
| Pole Size: | 8in Pipe Sch 40 |
| Pole Length above Grade: | 13.85 ft |
| Number of Poles: | 1 |
| Pole Spacing: | 0 |

Foundation Specifications

| | |
|--|----------------------|
| Foundation Type: | Square |
| Foundation Dimensions: | 48 x 48 in |
| Foundation Depth (below grade): | Pile 1: 6.50 ft |
| Foundation Volume: | 3.852 y ³ |

Site Info

| | |
|-----------------------------|---------------------------------------|
| Risk Category: | I |
| Exposure: | C |
| Soil Classification: | sand |
| Site Location: | XCMQ+2J2, Animas Forks, CO 81433, USA |
| Wind Speed: | 100 mph |
| Snow Load: | 321 psf |

Design Disclaimer

This software should be used for preliminary designs and should not be used as a final design unless reviewed, verified and designed by a qualified structural engineer.

AutoDesigner Input

```
{ "wind_speed_override": 100, "snow_load_override": 321, "direct_snow_load": false, "add_angle_brace": false, "product_type": "Beam", "designer_name": "", "designer_email": "", "designer_phone": "", "project_id": "Wayman-v4CU", "site_address": "XCMQ+2J2, Animas Forks, CO 81433, USA", "module_info": "", "module_width": 41.1, "module_length": 74, "number_rows": 5, "number_columns": 2, "pole_mount_section": "4_40", "core_pipe_width": 65, "core_pipe_section": "2_40", "adjuster_section": "2_40", "core_beam_height": 65, "core_beam_section": "HSS3x2x1/8", "main_pipe_section": "2_12GA", "pole_spacing": 15, "tilt_angle": 65, "ground_clearance": 6, "risk_category": "I", "exposure_category": "C", "frame_duty_override": "HD", "pole_override": "8_40", "soil_type": "sand", "customer_foundation_override": "48_Square", "foundation_type": "Square", "foundation_size": 48, "check_rails": false }
```

Design Notes:

- AISC Deflection checks are set to L/1 due to structure design intent
- Foundation Soil Parameters used in this Autodesign are all estimates, proper geotechnical reports are required to confirm soil profiles
- Wind speeds, snow loads and other site specific results are based on ASCE 7 2016
- Steel frame design checks are based on AISC 360 2016 (LRFD)
- Foundation Design and Sizing is approximate only

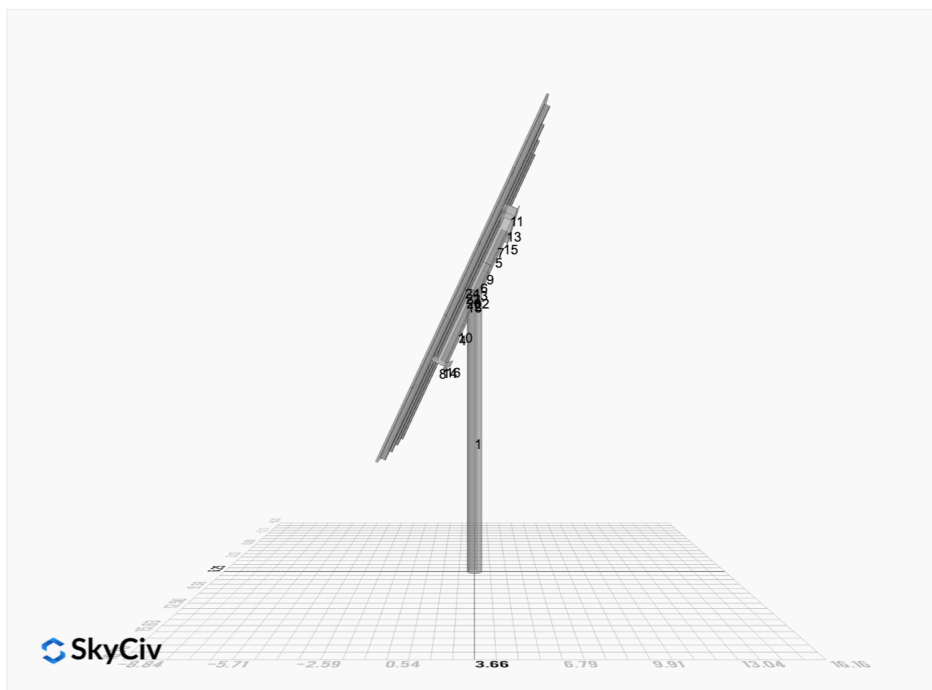
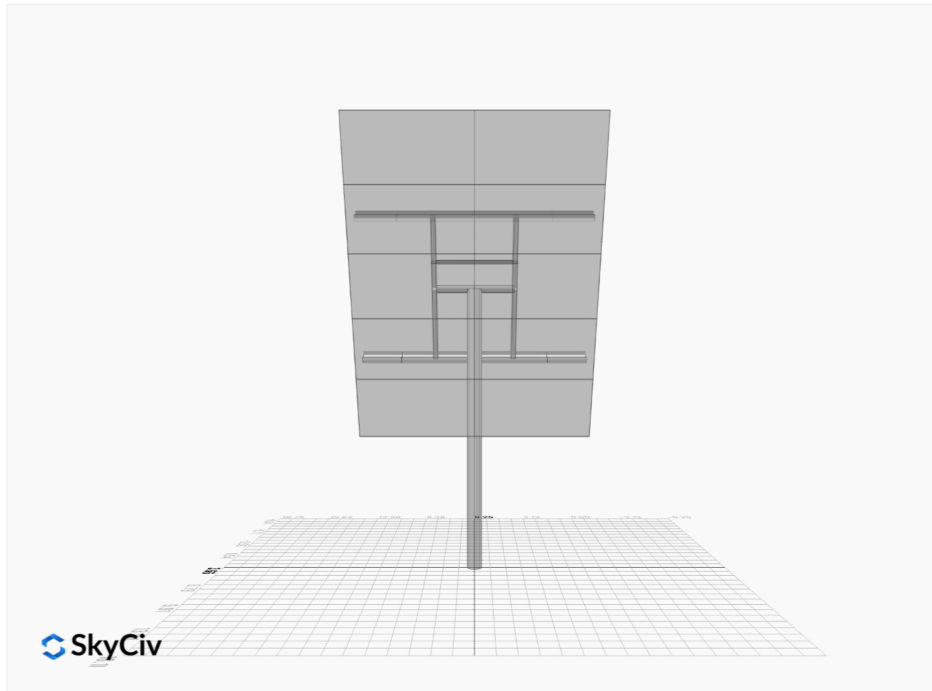

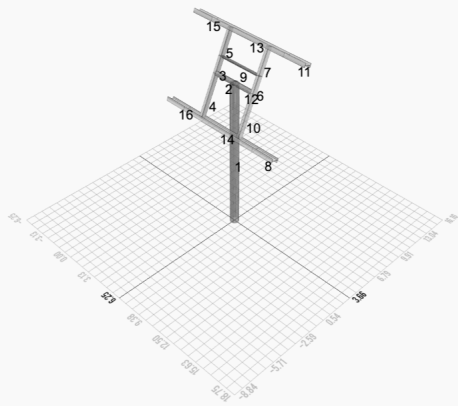
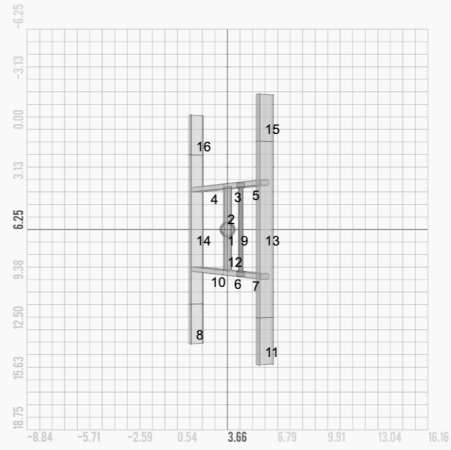

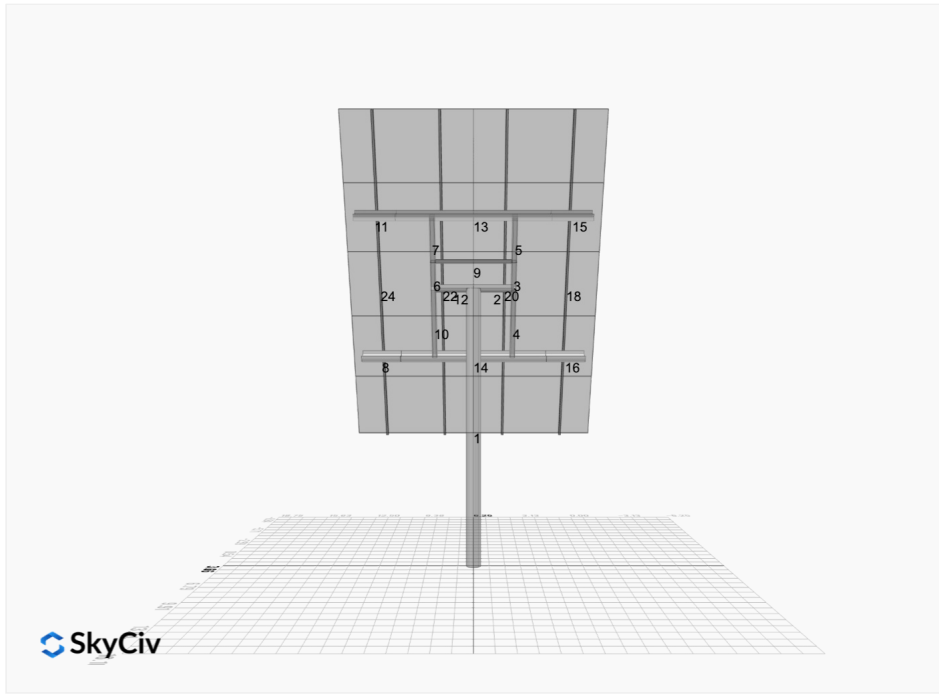

FEM Results (Envelope Worst Case for each member)

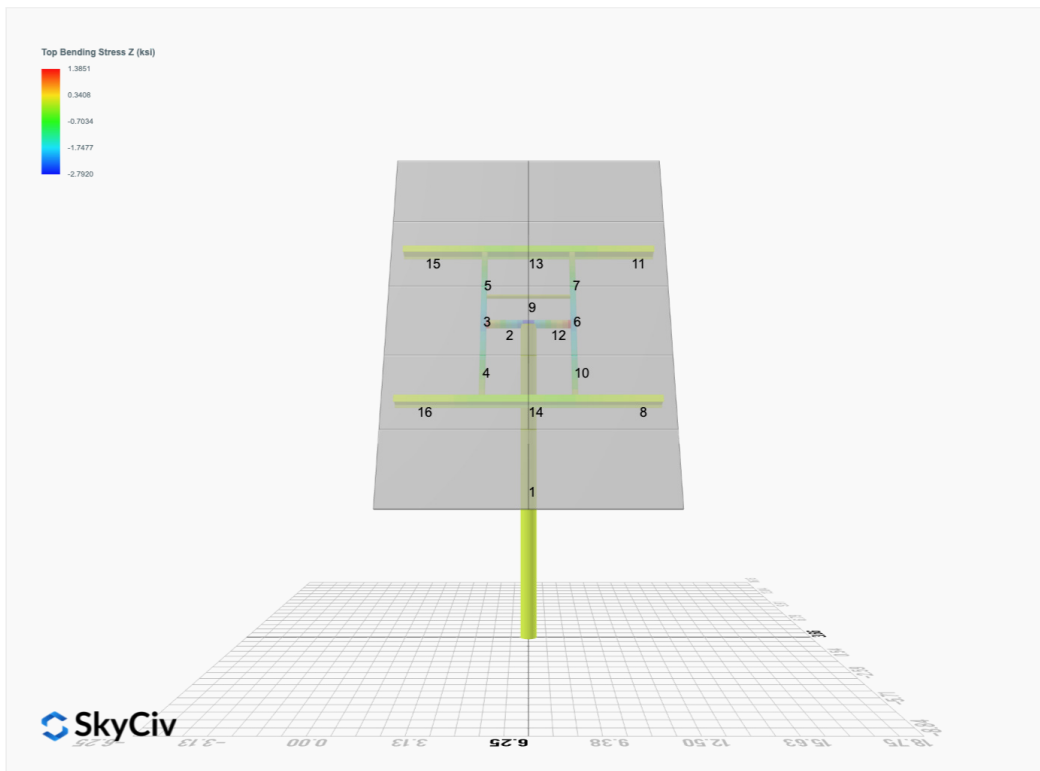
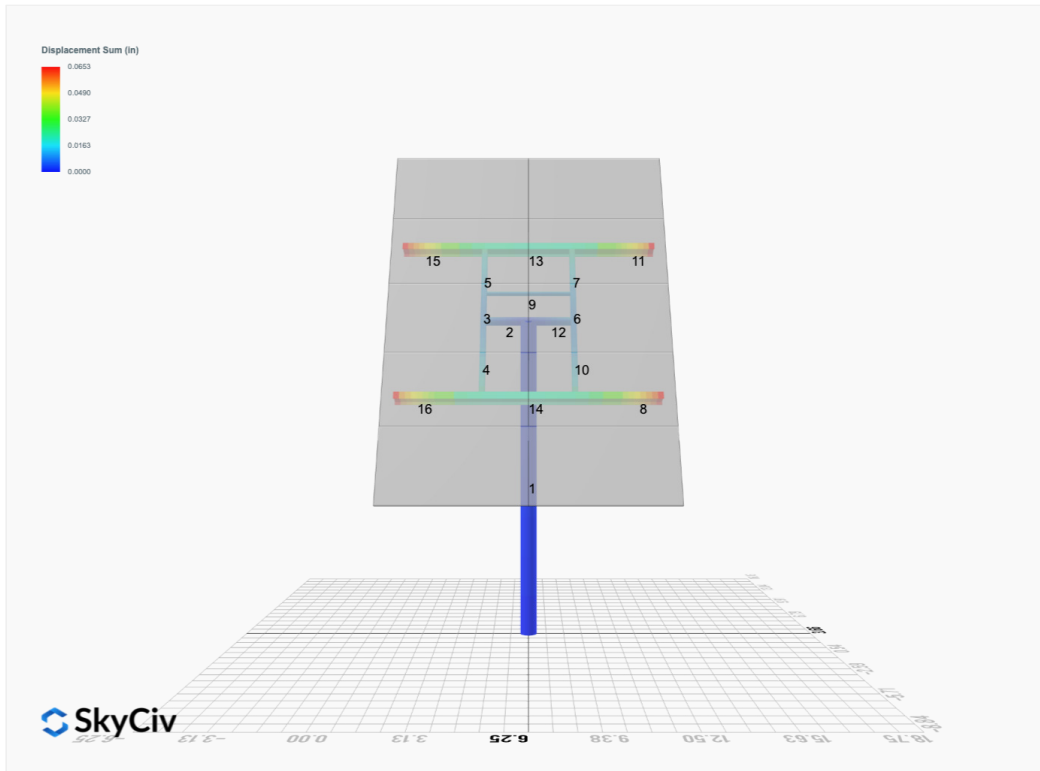

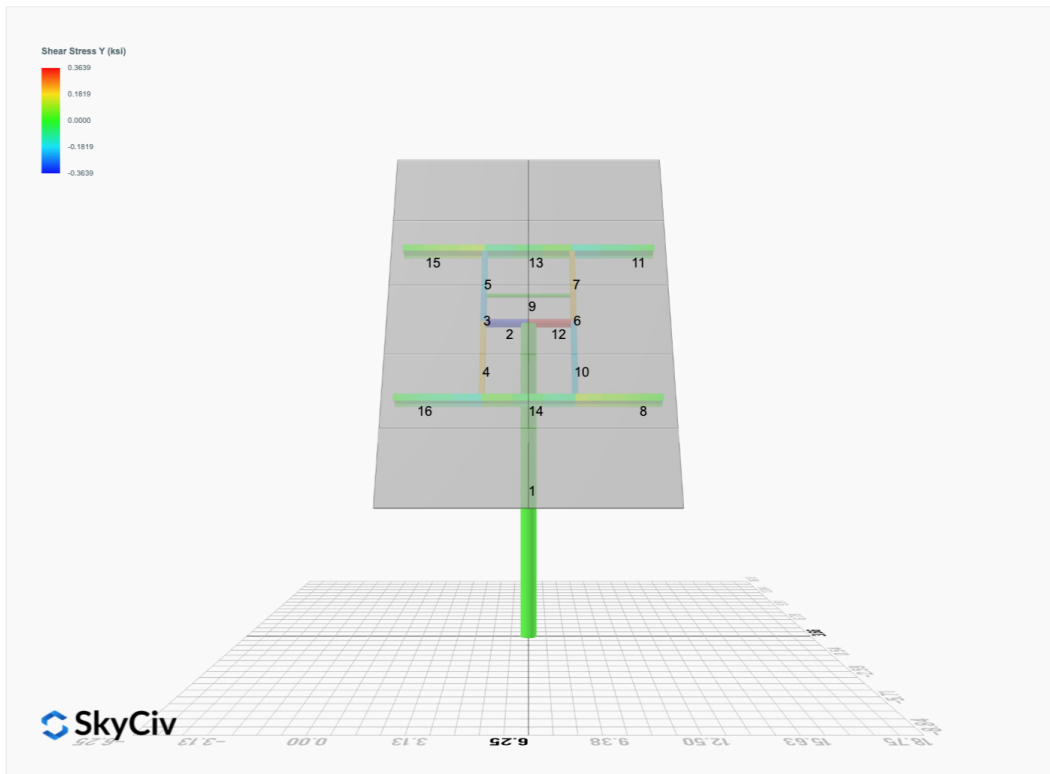
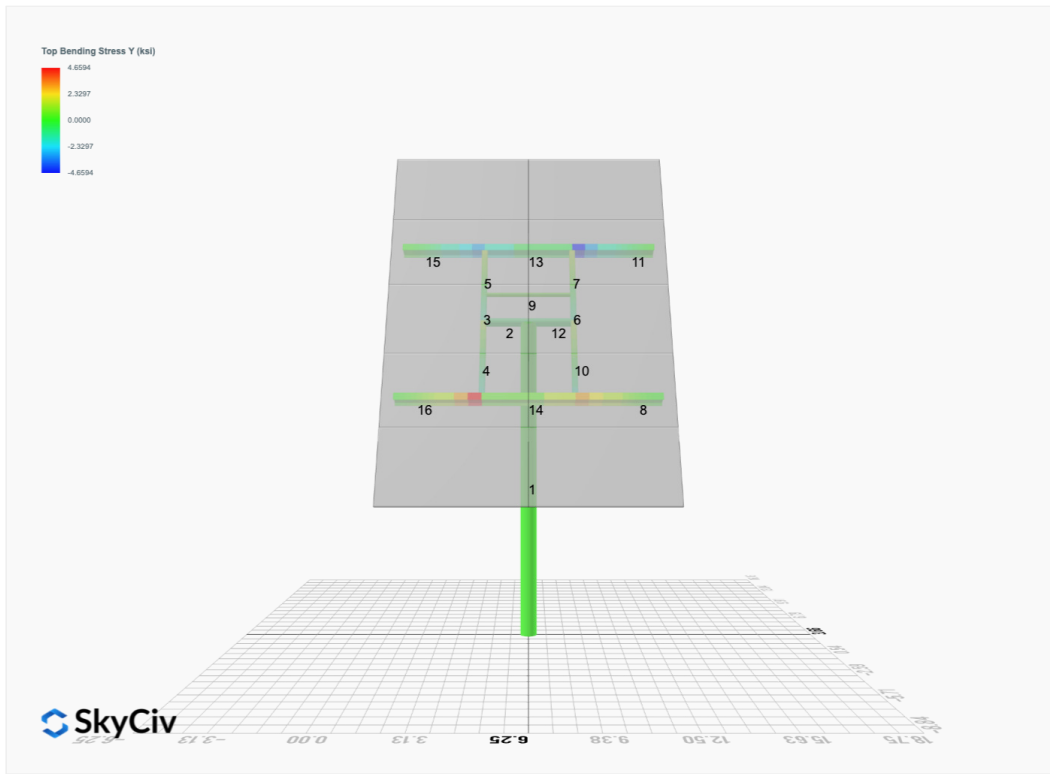

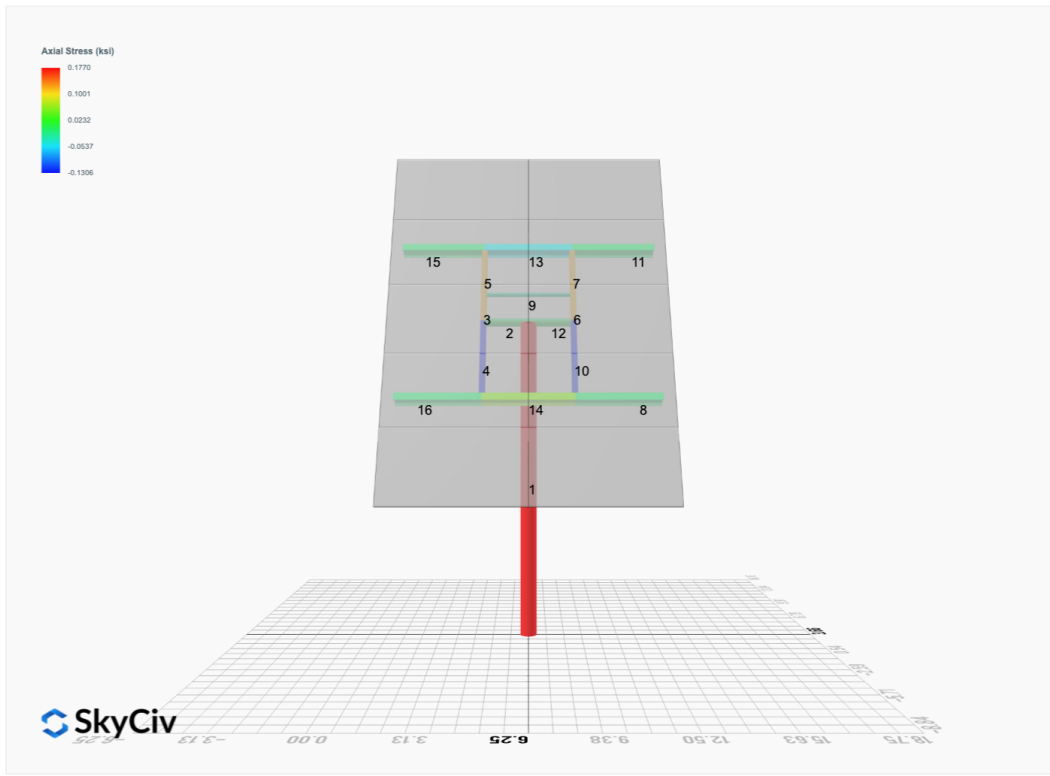

Reaction Forces for Foundation 1 (Node ID#1), (kip, kip-ft)

ASD Load Combination Results

| Name | Fx | Fy | Fz | Mx | My | Mz |
|---|---------|--------|--------|--------|---------|----------|
| ULS: 1. D | 0.0000 | 1.8261 | 0.0000 | 0.0000 | -0.0000 | 0.0131 |
| ULS: 2. D + L | 0.0000 | 1.8261 | 0.0000 | 0.0000 | -0.0000 | 0.0131 |
| ULS: 3. D + (S or Lr or R) | 0.0000 | 3.3129 | 0.0000 | 0.0000 | -0.0000 | 0.0153 |
| ULS: 3. D + (S or Lr or R) | 0.0000 | 1.8261 | 0.0000 | 0.0000 | -0.0000 | 0.0131 |
| ULS: 4. D + 0.75L + 0.75(S or Lr or R) | 0.0000 | 2.9412 | 0.0000 | 0.0000 | -0.0000 | 0.0148 |
| ULS: 4. D + 0.75L + 0.75(S or Lr or R) | 0.0000 | 1.8261 | 0.0000 | 0.0000 | -0.0000 | 0.0131 |
| ULS: 5b. D + 0.7E | 0.0000 | 1.8261 | 0.0000 | 0.0000 | -0.0000 | 0.0131 |
| ULS: 6b. D + 0.75L + 0.75(0.7)E + 0.75S | 0.0000 | 2.9412 | 0.0000 | 0.0000 | -0.0000 | 0.0148 |
| ULS: 8. 0.6D + 0.7E | 0.0000 | 1.0957 | 0.0000 | 0.0000 | -0.0000 | 0.0079 |
| ULS: 5a. D + 0.6W_Wind downforce Case A only | -1.9843 | 2.7514 | 0.0000 | 0.0000 | -0.0000 | 27.6923 |
| ULS: 5a. D + 0.6W_Wind downforce Case B only | 0.0000 | 1.8261 | 0.0000 | 0.0000 | -0.0000 | 0.0131 |
| ULS: 5a. D + 0.6W_Wind uplift Case A only | 1.9843 | 0.9008 | 0.0000 | 0.0000 | -0.0000 | -27.2943 |
| ULS: 5a. D + 0.6W_Wind uplift Case B only | 0.0000 | 1.8261 | 0.0000 | 0.0000 | -0.0000 | 0.0131 |
| ULS: 6a. D + 0.75L + 0.75(0.6)W + 0.75(S or Lr or R)_Wind downforce Case A only | -1.4882 | 3.6352 | 0.0000 | 0.0000 | -0.0000 | 20.7741 |
| ULS: 6a. D + 0.75L + 0.75(0.6)W + 0.75(S or Lr or R)_Wind downforce Case B only | 0.0000 | 2.9412 | 0.0000 | 0.0000 | -0.0000 | 0.0148 |
| ULS: 6a. D + 0.75L + 0.75(0.6)W + 0.75(S or Lr or R)_Wind uplift Case A only | 1.4882 | 2.2472 | 0.0000 | 0.0000 | -0.0000 | -20.4658 |
| ULS: 6a. D + 0.75L + 0.75(0.6)W + 0.75(S or Lr or R)_Wind uplift Case B only | 0.0000 | 2.9412 | 0.0000 | 0.0000 | -0.0000 | 0.0148 |
| ULS: 6a. D + 0.75L + 0.75(0.6)W + 0.75(S or Lr or R)_Wind downforce Case A only | -1.4882 | 2.5201 | 0.0000 | 0.0000 | -0.0000 | 20.7725 |
| ULS: 6a. D + 0.75L + 0.75(0.6)W + 0.75(S or Lr or R)_Wind downforce Case B only | 0.0000 | 1.8261 | 0.0000 | 0.0000 | -0.0000 | 0.0131 |
| ULS: 6a. D + 0.75L + 0.75(0.6)W + 0.75(S or Lr or R)_Wind uplift Case A only | 1.4882 | 1.1321 | 0.0000 | 0.0000 | -0.0000 | -20.4675 |
| ULS: 6a. D + 0.75L + 0.75(0.6)W + 0.75(S or Lr or R)_Wind uplift Case B only | 0.0000 | 1.8261 | 0.0000 | 0.0000 | -0.0000 | 0.0131 |
| ULS: 7. 0.6D + 0.6W_Wind downforce Case A only | -1.9843 | 2.0209 | 0.0000 | 0.0000 | -0.0000 | 27.6870 |
| ULS: 7. 0.6D + 0.6W_Wind downforce Case B only | 0.0000 | 1.0957 | 0.0000 | 0.0000 | -0.0000 | 0.0079 |
| ULS: 7. 0.6D + 0.6W_Wind uplift Case A only | 1.9843 | 0.1704 | 0.0000 | 0.0000 | -0.0000 | -27.2996 |
| ULS: 7. 0.6D + 0.6W_Wind uplift Case B only | 0.0000 | 1.0957 | 0.0000 | 0.0000 | -0.0000 | 0.0079 |

Worst Case Reactions LRFD

These calculations are taken directly from the FEA via SkyCiv and are used in the Concrete Checks of the Foundation Module.

Note: Worst case values are assumed as downforce wind load cases.

| Result | Value (kip, kip-ft) |
|------------------|---------------------|
| Axial | 5.3413 |
| Shear X | -3.3072 |
| Shear Z | 0.0000 |
| Moment X | 0.0000 |
| Moment Y (Twist) | 0.0000 |
| Moment Z | 46.7814 |

Worst Case Reactions ASD

These results are taken from the worst case values in the above table and are used in the Soil Checks in the Foundation Module.

Note: Worst case values are assumed as downforce wind load cases.

| Result | Value (kip, kip-ft) |
|------------------|---------------------|
| Axial | 3.6352 |
| Shear X | -1.9843 |
| Shear Z | 0.0000 |
| Moment X | 0.0000 |
| Moment Y (Twist) | 0.0000 |
| Moment Z | 27.6923 |

Project Details

Design Code: AISC 360-16 LRFD
 Provision: LRFD
 Country: United States
 User Name: sales@mtsolar.us
 Unit System: imperial



Design Input Information

| Design Factors | | | |
|----------------|----------|----------|----------|
| Φ_t | Φ_c | Φ_b | Φ_v |
| 0.9 | 0.9 | 0.9 | 0.9 |

| Design Materials | | | |
|------------------|---------|-------------|-------------|
| ID | E (ksi) | F_y (ksi) | F_u (ksi) |
| 1 | 29000 | 50 | 65 |

Section Dimensions

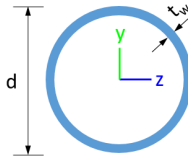

| ID | Name | d (in) | t_w (in) | | | | |
|----|-----------------|--------|------------|--|--|--|--|
| 2 | 2in Pipe Sch 80 | 2.38 | 0.22 | | | | |
| 5 | 4in Pipe Sch 80 | 4.50 | 0.34 | | | | |
| 9 | 8in Pipe Sch 40 | 8.63 | 0.32 | | | | |

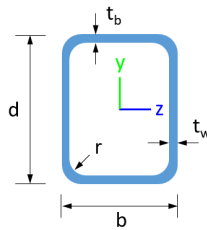

| ID | Name | d (in) | b (in) | t_w (in) | t_b (in) | r (in) | |
|----|-------------|--------|--------|------------|------------|--------|--|
| 16 | HSS5x3x3/16 | 5.00 | 3.00 | 0.17 | 0.17 | 0.17 | |

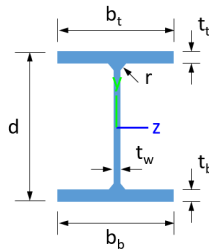

| ID | Name | d (in) | t_w (in) | b_t (in) | b_b (in) | t_t (in) | t_b (in) | r (in) |
|----|-------|--------|------------|------------|------------|------------|------------|--------|
| 19 | W8x10 | 7.89 | 0.17 | 3.94 | 3.94 | 0.20 | 0.20 | 0.30 |

Section Properties

| ID | Name | A (in ²) | J (in ⁴) | I_{yp} (in ⁴) | I_{zp} (in ⁴) | I_w (in ⁶) | S_{yp} (in ³) | S_{zp} (in ³) |
|----|------|----------------------|----------------------|-----------------------------|-----------------------------|--------------------------|-----------------------------|-----------------------------|
|----|------|----------------------|----------------------|-----------------------------|-----------------------------|--------------------------|-----------------------------|-----------------------------|

| | | | | | | |
|----|--------|--------|-------|------|-------|-------|
| 15 | 133.20 | 102.39 | 32.87 | 6.12 | 40.24 | 43.62 |
| 16 | 133.20 | 102.39 | 32.87 | 6.12 | 40.24 | 43.62 |

Design Ratio

| Member ID | P | M _z | M _y | V _y | V _z | (P,M _z ,M _y) | Worst LC | KL/r | δ | Status |
|-----------|-------|----------------|----------------|----------------|----------------|-------------------------------------|----------|--------------|--------------|--------|
| 1 | 0.040 | 0.562 | 0.000 | 0.029 | 0.000 | 0.578 | #13 | 0.594 | Not Required | Pass |
| 2 | 0.000 | 0.155 | 0.143 | 0.041 | 0.028 | 0.279 | #13 | 0.053 | Not Required | Pass |
| 3 | 0.008 | 0.278 | 0.065 | 0.028 | 0.020 | 0.319 | #13 | 0.045 | Not Required | Pass |
| 4 | 0.008 | 0.276 | 0.065 | 0.028 | 0.016 | 0.313 | #13 | 0.080 | Not Required | Pass |
| 5 | 0.008 | 0.172 | 0.065 | 0.027 | 0.015 | 0.179 | #13 | 0.074 | Not Required | Pass |
| 6 | 0.008 | 0.278 | 0.065 | 0.028 | 0.020 | 0.319 | #13 | 0.045 | Not Required | Pass |
| 7 | 0.008 | 0.172 | 0.065 | 0.027 | 0.015 | 0.179 | #13 | 0.074 | Not Required | Pass |
| 8 | 0.000 | 0.012 | 0.049 | 0.010 | 0.007 | 0.059 | #21 | Not Required | Not Required | Pass |
| 9 | 0.002 | 0.011 | 0.026 | 0.001 | 0.000 | 0.036 | #13 | 0.136 | Not Required | Pass |
| 10 | 0.008 | 0.276 | 0.065 | 0.028 | 0.016 | 0.313 | #13 | 0.080 | Not Required | Pass |
| 11 | 0.000 | 0.012 | 0.049 | 0.010 | 0.007 | 0.059 | #21 | Not Required | Not Required | Pass |
| 12 | 0.000 | 0.155 | 0.143 | 0.041 | 0.028 | 0.279 | #13 | 0.053 | Not Required | Pass |
| 13 | 0.003 | 0.065 | 0.174 | 0.019 | 0.013 | 0.216 | #21 | 0.190 | Not Required | Pass |
| 14 | 0.004 | 0.066 | 0.174 | 0.019 | 0.013 | 0.216 | #21 | 0.190 | Not Required | Pass |
| 15 | 0.000 | 0.012 | 0.049 | 0.010 | 0.007 | 0.059 | #21 | Not Required | Not Required | Pass |
| 16 | 0.000 | 0.012 | 0.049 | 0.010 | 0.007 | 0.059 | #21 | Not Required | Not Required | Pass |

Definitions

| | |
|-------------------------------------|---|
| Φ _t | Safety factor for tensile |
| Φ _c | Safety factor for compression |
| Φ _b | Safety factor for flexure |
| Φ _v | Safety factor for shear |
| E | Modulus of elasticity |
| F _y | Specified minimum yield stress |
| F _u | Specified minimum tensile strength |
| A | Cross-sectional area |
| J | Torsional constant |
| I _{yp} | Moment of inertia about the Y axes |
| I _{zp} | Moment of inertia about the Z axes |
| I _w | Warping constant |
| S _{yp} | Plastic section modulus about the Y axis |
| S _{zp} | Plastic section modulus about the Z axis |
| KL | Effective length |
| C _b | Buckling modification factor (from all load combinations) |
| L _b | Length between braced points |
| LST | Limited slenderness for tension |
| LSC | Limited slenderness for compression |
| LD | Limited deflection |
| P _n | Nominal axial strength (tension/compression) |
| M _n | Nominal flexural strength (about Z/Y axis) |
| V _n | Nominal shear strength (along Z/Y axis) |
| P | Design ratio in case of axial force |
| M _z | Design ratio in case of bending about Z axis |
| M _y | Design ratio in case of bending about Y axis |
| V _y | Design ratio in case of shear along Y axis |
| V _z | Design ratio in case of shear along Z axis |
| (P,M _z ,M _y) | Design ratio in case of axial force and bending action |
| KL/r | Design ratio in case of section slenderness |
| δ | Design ratio in case of member deflection |
| OK | Capacity is provided |
| NG | Capacity is not provided |

| REFERENCES | CALCULATIONS | RESULTS |
|------------|--------------|---------|
|------------|--------------|---------|

SkyCiv Foundation Design

Pile Foundation

Design Information :

Design code : IBC 2021 (International Building Code)
Unit System : Imperial

Pile Input

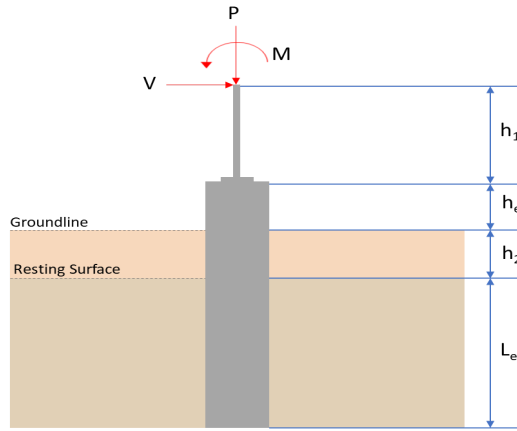

Geometry

Pile shape: rectangular

$b = 48$ in - Pile width

$D = 48$ in - Pile depth

$L = 6.5$ ft - Total pile length

$h_1 = 0$ ft - Lateral load height from the top of the pile,

$h_2 = 0$ ft - Depth to resisting surface

$h_e = 0$ ft - Length of pile above the ground

Tabulation of Soil Parameters

| Layer | Label | Allowable Bearing Pressure (q_a) (psf) | Allowable Lateral Pressure (R) (psf/ft) |
|-------|---|--|---|
| 1 | Sand, silty sand, clayey sand, silty gravel & clayey gravel | 2000.000 | 150.000 |

Tabulation of Loads

| Load Component | ASD | LRFD |
|----------------|--------|--------|
| P (kip) | 3.635 | 5.341 |
| V_x (kip) | -1.984 | -3.307 |
| V_z (kip) | 0.000 | 0.000 |
| M_x (kipft) | 0.000 | 0.000 |
| M_z (kipft) | 27.692 | 46.781 |

Material Properties

$f'_{ck} = 2.5$ ksi - Concrete strength.

Required depth to resist lateral loads (ASD)

H - Point of application of the lateral load

$$H = h_1 + h_2 + h_e$$

$$H = (0 \text{ ft}) + (0 \text{ ft}) + (0 \text{ ft})$$

$$H = 0 \text{ ft}$$

Considering x-direction:

H_o - Lateral force per length of pile,

$$H_o = \frac{V_x}{1.57 D}$$

$$H_o = \frac{(-1.984 \text{ kip})}{1.57 \times (48 \text{ in})}$$

$$H_o = -0.31592 \text{ kip/ft}$$

M_o - Moment per length of pile,

$$M_o = \frac{M_z + (V_x H)}{1.57 D}$$

$$M_o = \frac{(27.692 \text{ kipft}) + ((-1.984 \text{ kip}) \times (0 \text{ ft}))}{1.57 \times (48 \text{ in})}$$

$$M_o = 4.4096 \text{ kipft/ft}$$

Required depth of embedment in earth:

$$L_x^3 - \left(14.14 \times \frac{H_o \times L_x}{R}\right) - \left(18.85 \times \frac{M_o}{R}\right) = 0$$

Solving the cubic equation:

$L_{e,x} = 6.1769 \text{ ft}$ - Required depth in x-direction,

Considering z-direction:

$L_{e,z} = 0 \text{ ft}$ - Required depth in z-direction,

Minimum embedded depth required:

$L_{e,req}$ - Depth of pile required,

$$L_{e,req} = \text{MAX}[L_{e,x}, L_{e,z}]$$

$$L_{e,req} = \text{MAX}[(6.1769 \text{ ft}), (0 \text{ ft})]$$

$$L_{e,req} = 6.177 \text{ ft}$$

L_e - Actual embedded length of pile,

$$L_e = L - h_e - h_2$$

$$L_e = (6.5 \text{ ft}) - (0 \text{ ft}) - (0 \text{ ft})$$

$$L_e = 6.5 \text{ ft}$$

Ratio - Embedded depth

$$\text{Ratio} = \frac{L_{e,req}}{L_e}$$

$$\text{Ratio} = \frac{(6.177 \text{ ft})}{(6.5 \text{ ft})}$$

$$\text{Ratio} = 0.95031$$

Status: **PASS**
Ratio: **0.950**

End-bearing Capacity (ASD)

A - Pile cross-section area

$$A = b D$$

$$A = (48 \text{ in}) \times (48 \text{ in})$$

$$A = 16 \text{ ft}^2$$

q - End-bearing pressure

$$q = \frac{P_v}{A}$$

$$q = \frac{(3.635 \text{ kip})}{(16 \text{ ft}^2)}$$

$$q = 0.22719 \text{ kip/ft}^2$$

Check bearing capacity ratio:

Ratio - Capacity

$$\text{Ratio} = \frac{q}{q_a}$$

$$\text{Ratio} = \frac{(0.22719 \text{ kip/ft}^2)}{(2000 \text{ psf})}$$

$$\text{Ratio} = 0.11359$$

Status: **PASS**
Ratio: **0.110**

Czerniak

Lateral Soil Pressure (ASD):

L/D - Length to least lateral dimension ratio,

$$L/D = \frac{L}{D}$$

$$L/D = \frac{(6.5 \text{ ft})}{(48 \text{ in})}$$

$$L/D = 1.625$$

Since $L/D \leq 10$,

Pile is short.

Considering x-direction:

$H_o = -0.31592 \text{ kip/ft}$ - Lateral force per length of pile,

$M_o = 4.4096 \text{ kipft/ft}$ - Overturning moment per length of pile,

a - Distance from resting surface to pivot point,

$$a = \frac{(4 M_o L_e) + (3 H_o L_e^2)}{(6 M_o) + (4 H_o L_e)}$$

$$a = \frac{(4 \times (4.4096 \text{ kipft/ft}) \times (6.5 \text{ ft})) + (3 \times (-0.31592 \text{ kip/ft}) \times (6.5 \text{ ft})^2)}{(6 \times (4.4096 \text{ kipft/ft})) + (4 \times (-0.31592 \text{ kip/ft}) \times (6.5 \text{ ft}))}$$

$$a = 4.4617 \text{ ft}$$

p - Earth pressure against the pile at distance $a/2$ from resting surface,

$$p = \frac{0.75 [(4 M_o) + (3 H_o L_e)]^2}{L_e^2 [(3 M_o) + (2 H_o L_e)]}$$

$$p = \frac{0.75 \times [(4 \times (4.4096 \text{ kipft/ft})) + (3 \times (-0.31592 \text{ kip/ft}) \times (6.5 \text{ ft}))]^2}{(6.5 \text{ ft})^2 \times [(3 \times (4.4096 \text{ kipft/ft})) + (2 \times (-0.31592 \text{ kip/ft}) \times (6.5 \text{ ft}))]}$$

$$p = 0.25637 \text{ kip/ft}^2$$

s - Earth pressure against the pile at distance L_e ,

$$s = \frac{6 [(2 M_o) + (H_o L_e)]}{L_e^2}$$

$$s = \frac{6 \times [(2 \times (4.4096 \text{ kipft/ft})) + ((-0.31592 \text{ kip/ft}) \times (6.5 \text{ ft}))]}{(6.5 \text{ ft})^2}$$

$$s = 0.9608 \text{ kip/ft}^2$$

Check lateral soil pressure capacity:

p_a - Allowable lateral soil pressure at depth $a/2$,

$$p_a = R \frac{a}{2}$$

$$p_a = (150 \text{ psf/ft}) \times \frac{(4.4617 \text{ ft})}{2}$$

$$p_a = 0.33462 \text{ kip/ft}^2$$

Ratio - Lateral soil capacity

$$\text{Ratio} = \frac{p}{p_a}$$

$$\text{Ratio} = \frac{(0.25637 \text{ kip/ft}^2)}{(0.33462 \text{ kip/ft}^2)}$$

$$\text{Ratio} = 0.76615$$

p_s - Allowable lateral soil pressure at depth L_e ,

$$p_s = R L_e$$

$$p_s = (150 \text{ psf/ft}) \times (6.5 \text{ ft})$$

$$p_s = 0.975 \text{ kip/ft}^2$$

Ratio - Lateral soil capacity

$$\text{Ratio} = \frac{s}{p_s}$$

$$\text{Ratio} = \frac{(0.9608 \text{ kip/ft}^2)}{(0.975 \text{ kip/ft}^2)}$$

Status: **PASS**
Ratio: **0.770**



Shear force and Bending moment (x-direction, LRFD)

H_o - Lateral force per length of pile,

$$H_o = \frac{V_x}{1.57 D}$$

$$H_o = \frac{(-3.307 \text{ kip})}{1.57 \times (48 \text{ in})}$$

$$H_o = -0.52659 \text{ kip/ft}$$

M_o - Moment per length of pile,

$$M_o = \frac{M_z + (V_x H)}{1.57 D}$$

$$M_o = \frac{(46.781 \text{ kipft}) + ((-3.307 \text{ kip}) \times (0 \text{ ft}))}{1.57 \times (48 \text{ in})}$$

$$M_o = 7.4492 \text{ kipft/ft}$$

E - Distance from lateral load to resisting surface,

$$E = \frac{M_o}{H_o}$$

$$E = \frac{(7.4492 \text{ kipft/ft})}{(-0.52659 \text{ kip/ft})}$$

$$E = 14.146 \text{ ft}$$

a - Distance from resting surface to pivot point,

$$a = \frac{(4 M_o L_e) + (3 H_o L_e^2)}{(6 M_o) + (4 H_o L_e)}$$

$$a = \frac{(4 \times (7.4492 \text{ kipft/ft}) \times (6.5 \text{ ft})) + (3 \times (-0.52659 \text{ kip/ft}) \times (6.5 \text{ ft})^2)}{(6 \times (7.4492 \text{ kipft/ft})) + (4 \times (-0.52659 \text{ kip/ft}) \times (6.5 \text{ ft}))}$$

$$a = 4.4604 \text{ ft}$$

V_{max} - Max shear force located at depth a ,

$$V_{max} = (H_o D) \left[1 - \left[3 \left(\frac{4 E}{L_e} + 3 \right) \left(\frac{a}{L_e} \right)^2 \right] + \left[4 \left(\frac{3 E}{L_e} + 2 \right) \left(\frac{a}{L_e} \right)^3 \right] \right]$$

$$V_{max} = ((-0.52659 \text{ kip/ft}) \times (48 \text{ in})) \times \left[1 - \left[3 \times \left(\frac{4 \times (14.146 \text{ ft})}{(6.5 \text{ ft})} + 3 \right) \times \left(\frac{(4.4604 \text{ ft})}{(6.5 \text{ ft})} \right)^2 \right] + \left[4 \times \left(\frac{3 \times (14.146 \text{ ft})}{(6.5 \text{ ft})} + 2 \right) \times \left(\frac{(4.4604 \text{ ft})}{(6.5 \text{ ft})} \right)^3 \right] \right]$$

$$v_{max} = 9.5559 \text{ kip}$$

M_{max} - Max bending moment located at depth $a/2$,

$$M_{max} = (H_o D L_e) \left[\left(\frac{E}{L_e} + \frac{a}{2 L_e} \right) - \left[\left(\frac{4 E}{L_e} + 3 \right) \left(\frac{a}{2 L_e} \right)^3 + \left[\left(\frac{3 E}{L_e} + 2 \right) \left(\frac{a}{2 L_e} \right)^4 \right] \right]$$

$$M_{max} = ((-0.52659 \text{ kip/ft}) \times (48 \text{ in}) \times (6.5 \text{ ft})) \times \left[\left(\frac{(14.146 \text{ ft})}{(6.5 \text{ ft})} + \frac{(4.4604 \text{ ft})}{2 \times (6.5 \text{ ft})} \right) - \left[\left(\frac{4 \times (14.146 \text{ ft})}{(6.5 \text{ ft})} + 3 \right) \times \left(\frac{(4.4604 \text{ ft})}{2 \times (6.5 \text{ ft})} \right)^3 + \left[\left(\frac{3 \times (14.146 \text{ ft})}{(6.5 \text{ ft})} + 2 \right) \times \left(\frac{(4.4604 \text{ ft})}{2 \times (6.5 \text{ ft})} \right)^4 \right] \right]$$

$$M_{max} = 29.64 \text{ kipft}$$

Minimum Reinforcement Check (LRFD)

Parameters:

$f'_{ck} = 2.5 \text{ ksi}$ - Concrete strength,
 $f_{yk} = 60 \text{ ksi}$ - Longitudinal reinforcement strength,
 $\phi = 0.65$ - Reduction factor for axial strength,
 $\alpha = 0.8$ - Alpha factor for axial strength,
 $A_g = 2304 \text{ in}^2$ - Gross area of concrete,

Table 22.4.2.1

Longitudinal reinforcement:

Required reinforcement due to axial load, $A_{st,required}$

22.4.2.2, 10.6.1.1

$A_{st,required}$

$$A_{st,required} = \text{Min} \left[\frac{\frac{P}{\phi \alpha} - (0.85 f'_{ck} A_g)}{f_{yk} - (0.85 f'_{ck})}, (0.08 A_g) \right]$$

$$A_{st,required} = \text{Min} \left[\frac{\frac{(5.341 \text{ kip})}{(0.65) \times (0.8)} - (0.85 \times (2.5 \text{ ksi}) \times (2304 \text{ in}^2))}{(60 \text{ ksi}) - (0.85 \times (2.5 \text{ ksi}))}, (0.08 \times (2304 \text{ in}^2)) \right]$$

$$A_{st,required} = -84.419 \text{ in}^2$$

A_{min} - Governing minimum reinforcement area,

$$A_{min} = \text{Max} [A_{st,required}, (0.0018 A_g)]$$

$$A_{min} = \text{Max} [(-84.419 \text{ in}^2), (0.0018 \times (2304 \text{ in}^2))]$$

$$A_{min} = 4.1472 \text{ in}^2$$

n_{rebar} - Required number of reinforcement,

$$n_{rebar} = \frac{A_{min}}{A_{rebar}}$$

$$n_{rebar} = \frac{(4.1472 \text{ in}^2)}{(0.3068 \text{ in}^2)}$$

$$n_{rebar} = 14$$

A_{st} - Actual total reinforcement area,

$$A_{st} = n_{rebar} \frac{\pi d_{bar}^2}{4}$$

$$A_{st} = (14) \times \frac{\pi \times (0.625 \text{ in})^2}{4}$$

$$A_{st} = 4.2951 \text{ in}^2$$

Ratio - Capacity

$$\text{Ratio} = \frac{A_{min}}{A_{st}}$$

$$\text{Ratio} = \frac{(4.1472 \text{ in}^2)}{(4.2951 \text{ in}^2)}$$

$$\text{Ratio} = 0.96556$$

25.2.3

s_{rebar} - Minimum spacing of reinforcement,

$$s_{rebar} = \text{Max} [1.5, (1.5 d_{bar})]$$

Status: **PASS**
Ratio: **0.970**

$$s_{rebar} = Max[1.5, (1.5 \times (0.625 \text{ in}))]$$

$$s_{rebar} = 1.5 \text{ in}$$

Ties:

25.7.2.2 Since longitudinal reinforcement is \leq No. 10 \emptyset : Use #3(0.375 in)

25.7.2.1 s_{ties} - Maximum spacing of ties,

$$s_{ties} = Min[(16 d_{bar}), (48 d_{ties}), Min(D, b)]$$

$$s_{ties} = Min[(16 \times (0.625 \text{ in})), (48 \times (0.375 \text{ in})), Min((48 \text{ in}), (48 \text{ in}))]$$

$$s_{ties} = 10 \text{ in}$$

Summary:

Main reinforcement: **14 - #5 (0.625 in)**

Ties: **#3(0.375 in) - 10 in**

Axial Compression Strength (ACI 318-19, LRFD)

22.4.2.2 ϕP_N - Allowable axial compressive strength

$$\phi P_N = \phi 0.80 [(0.85 f'_{ck} [A_g - A_{st}]) + (f_{yk} A_{st})]$$

$$\phi P_N = (0.65) \times 0.80 \times [(0.85 \times (2.5 \text{ ksi}) \times [(2304 \text{ in}^2) - (4.2951 \text{ in}^2)]) + ((60 \text{ ksi}) \times (4.2951 \text{ in}^2))]$$

$$\phi P_N = 2675.2 \text{ kip}$$

Ratio - Capacity

$$Ratio = \frac{P}{\phi P_N}$$

$$Ratio = \frac{(5.341 \text{ kip})}{(2675.2 \text{ kip})}$$

$$Ratio = 0.0019965$$

Status: **PASS**
Ratio: **0.000**

Shear Strength (ACI 318-19, LRFD)

Parameters:

$b_w = 48 \text{ in}$ - Effective width,

22.5.2.2 d - Effective depth

$$d = 0.80 D$$

$$d = 0.80 \times (48 \text{ in})$$

$$d = 38.4 \text{ in}$$

22.5.5.1.3 λ_s - size effect modification factor

$$\lambda_s = MIN \left[\sqrt{\frac{2}{1 + \frac{d}{10}}}, 1 \right]$$

$$\lambda_s = MIN \left[\sqrt{\frac{2}{1 + \frac{(38.4 \text{ in})}{10}}}, 1 \right]$$

$$\lambda_s = 0.64282$$

The following variables were converted to be consistent with empirical formula $f'_{ck} = 2.5 \text{ ksi} \rightarrow 2500 \text{ psi}$,

22.5.5.1.1 $V_{c,max}$ - Max shear strength of concrete

$$V_{c,max} = 5 \lambda_s \sqrt{f'_{ck}} b_w d$$

$$V_{c,max} = 5 \times (0.64282) \times \sqrt{(2500 \text{ psi})} \times (48 \text{ in}) \times (38.4 \text{ in})$$

$$V_{c,max} = 296.21 \text{ kip}$$

The following variables were converted to be consistent with empirical formula $f'_{ck} = 2.5 \text{ ksi} \rightarrow 2500 \text{ psi}$, $P = 5.341 \text{ kip} \rightarrow 5341 \text{ lbf}$,

22.5.5.1.1(a) $V_{c,a}$ - Shear strength of concrete (a)

$$V_{c,a} = \left[2 \lambda_s \sqrt{f'_{ck}} + \frac{P}{6 A_g} \right] b_w d$$

$$V_{c,a} = \left[2 \times (0.64282) \times \sqrt{(2500 \text{ psi})} + \frac{(5341 \text{ lbf})}{6 \times (2304 \text{ in}^2)} \right] \times (48 \text{ in}) \times (38.4 \text{ in})$$

$$V_{c,a} = 119.2 \text{ kip}$$

22.5.5.1.2 The following variables were converted to be consistent with empirical formula $f'_{ck} = 2.5 \text{ ksi} \rightarrow 2500 \text{ psi}$,
 $V_{c,b}$ - Shear strength of concrete (b)

$$V_{c,b} = \left[2 \lambda_s \sqrt{f'_{ck}} + (0.05 f'_{ck}) \right] b_w d$$

$$V_{c,b} = \left[2 \times (0.64282) \times \sqrt{(2500 \text{ psi})} + (0.05 \times (2500 \text{ psi})) \right] \times (48 \text{ in}) \times (38.4 \text{ in})$$

$$V_{c,b} = 348.89 \text{ kip}$$

V_c - Governing shear strength of concrete

$$V_c = \text{Min} [V_{c,max}, V_{c,a}, V_{c,b}]$$

$$V_c = \text{Min} [(296.21 \text{ kip}), (119.2 \text{ kip}), (348.89 \text{ kip})]$$

$$V_c = 119.2 \text{ kip}$$

22.5.1.2 The following variables were converted to be consistent with empirical formula $f'_{ck} = 2.5 \text{ ksi} \rightarrow 2500 \text{ psi}$,
 $V_{s,a}$ - Shear strength of steel (a)

$$V_{s,a} = 8 \sqrt{f'_{ck}} b_w d$$

$$V_{s,a} = 8 \times \sqrt{(2500 \text{ psi})} \times (48 \text{ in}) \times (38.4 \text{ in})$$

$$V_{s,a} = 737.28 \text{ kip}$$

A_v - Ties rebar area,

$$A_v = \frac{\pi d_{ties}^2}{4}$$

$$A_v = \frac{\pi \times (0.375 \text{ in})^2}{4}$$

$$A_v = 0.11045 \text{ in}^2$$

22.5.8.5.3 $V_{s,b}$ - Shear strength of steel (b)

$$V_{s,b} = \frac{2 A_v f_{yw} d}{s_{ties}}$$

$$V_{s,b} = \frac{2 \times (0.11045 \text{ in}^2) \times (60 \text{ ksi}) \times (38.4 \text{ in})}{(10 \text{ in})}$$

$$V_{s,b} = 50.894 \text{ kip}$$

V_s - Governing shear strength of steel

$$V_s = \text{MIN} [V_{s,a}, V_{s,b}]$$

$$V_s = \text{MIN} [(737.28 \text{ kip}), (50.894 \text{ kip})]$$

$$V_s = 50.894 \text{ kip}$$

22.5.1.1 ϕV_n - Allowable shear strength

$$\phi V_n = \phi (V_c + V_s)$$

$$\phi V_n = (0.65) \times ((119.2 \text{ kip}) + (50.894 \text{ kip}))$$

$$\phi V_n = 110.56 \text{ kip}$$

Considering x-direction:

$V_{max} = 9.5035 \text{ kip}$ - Maximum shear force in the x-direction,

Ratio - Capacity

$$\text{Ratio} = \frac{V_{max}}{\phi V_n}$$

$$\text{Ratio} = \frac{(9.5035 \text{ kip})}{(110.56 \text{ kip})}$$

$$\text{Ratio} = 0.085958$$

Status: **PASS**
Ratio: **0.090**

Flexural Strength (ACI 318-19, LRFD)

S_m - Section modulus

$$S_m = \frac{b D^2}{6}$$

$$S_m = \frac{(48 \text{ in}) \times (48 \text{ in})^2}{6}$$

$$S_m = 18432 \text{ in}^3$$

$\lambda = 1$ - Concrete modification factor (Normal concrete),

Allowable flexural strength:

M_n shall be the lesser of:

$\phi M_{n,1}$

$$\phi M_{n,1} = \phi \times 5 \times \lambda \times \sqrt{f'_c} \times S_m$$

$$\phi M_{n,1} = 0.65 \times 5 \times 1 \times \sqrt{2.5 \text{ ksi}} \times 18432.001 \text{ in}^3$$

$$\phi M_{n,1} = 249.600 \text{ kipft}$$

14.5.2.1b

$\phi M_{n,2}$

$$\phi M_{n,2} = \phi \times 0.85 \times f'_c \times S_m$$

$$\phi M_{n,2} = (0.65) \times 0.85 \times (2.5 \text{ ksi}) \times (18432 \text{ in}^3)$$

$$\phi M_{n,2} = 2121.6 \text{ kipft}$$

Therefore,

ϕM_n - Allowable flexural strength,

$$\phi M_n = \text{MIN}[\phi M_{n,1}, \phi M_{n,2}]$$

$$\phi M_n = \text{MIN}[(249.6 \text{ kipft}), (2121.6 \text{ kipft})]$$

$$\phi M_n = 249.6 \text{ kipft}$$

Considering x-direction:

$M_{max} = 29.64 \text{ kipft}$ - Maximum moment in the x-direction,

Ratio - Capacity

$$\text{Ratio} = \frac{M_{max}}{\phi M_n}$$

$$\text{Ratio} = \frac{(29.64 \text{ kipft})}{(249.6 \text{ kipft})}$$

$$\text{Ratio} = 0.11875$$

Status: **PASS**
Ratio: **0.120**