

Your Project Calculations



Project Name: 201 FOX STAGE 1_rev.cu.a

S3D Model Link:

https://platform.skyciv.com/structural?preload_name=201%20FOX%20STAGE%201_rev.cu.a&preload_path=Shared%20Enterprise%20Folder/MT_Solar_Projects/3_2023

Public Model Link:

https://platform.skyciv.com/structural-viewer?project_id=BUd3XJYBtjz3wyufSV7ptuCq5HEaoTCjGLym7MiWcy5mqGsaYanxh6KwtugES6h0

Array Specification

Product:	Beam
Unique ID:	1P-0-6TOP-SD-24-L-5Hx2W-1KAD
Duty Classification:	SD
Module Width:	40.00 in
Module Length:	71.70in
Number of Rows:	5
Number of Columns:	2
Total Number of Modules:	10
Desired Tilt Angle:	70
Front Edge Clearance:	6.6
Total Array Height at Tilt:	22.36 ft
Total Frame Length:	11.50 ft
Frame Weight:	773 lbs
Array Dimensions N/S:	16.88 ft
Array Dimensions E/W:	12.12 ft
Rail Length:	202.50 in
Rail Spacing:	2.99 ft
Rail Check:	Not Checked

Support Specifications

Pole Size:	6in Pipe Sch 80
Pole Length above Grade:	14.53 ft
Number of Poles:	1
Pole Spacing:	0

Foundation Specifications

Foundation Type:	Square
Foundation Dimensions:	48 x 48 in
Foundation Depth (below grade):	Pile 1: 6.50 ft
Foundation Volume:	3.852 y ³
Foundation Result:	PASSED

Site Info

Risk Category:	I
Exposure:	B
Soil Classification:	sand
Site Location:	201 Fox St, Madawaska, ME 04756, USA
Wind Speed:	95 mph
Snow Load:	100 psf
Design Uplift Pressure:	0.016225 ksf
Design Downforce Pressure:	-0.016225 ksf
Design Snow Pressure:	0.000000 ksf



Design Disclaimer

This software should be used for preliminary designs and should not be used as a final design unless reviewed, verified and designed by a qualified structural engineer.

AutoDesigner Input

```
{
  "wind_speed_override": null,
  "snow_load_override": null,
  "direct_snow_load": false,
  "product_type": "Beam",
  "project_id": "201 FOX STAGE 1_rev.cu.a",
  "site_address": "201 Fox St, Madawaska, ME 04756, USA",
  "module_width": 40,
  "module_length": 71.7,
  "number_rows": 5,
  "number_columns": 2,
  "pole_mount_section": "4_40",
  "core_pipe_width": 65,
  "core_pipe_section": "2_40",
  "adjuster_section": "2_40",
  "core_beam_height": 65,
  "core_beam_section": "HSS3x2x1/8",
  "main_pipe_section": "2_12GA",
  "pole_spacing": 15,
  "tilt_angle": 70,
  "ground_clearance": 6.6,
  "risk_category": "I",
  "exposure_category": "B",
  "frame_duty_override": "auto",
  "pole_override": "auto",
  "soil_type": "sand",
  "foundation_type": "Square",
  "foundation_size": 48,
  "check_rails": false
}
```

Design Notes:

- AISC Deflection checks are set to L/1 due to structure design intent
- Foundation Design and Sizing is approximate only

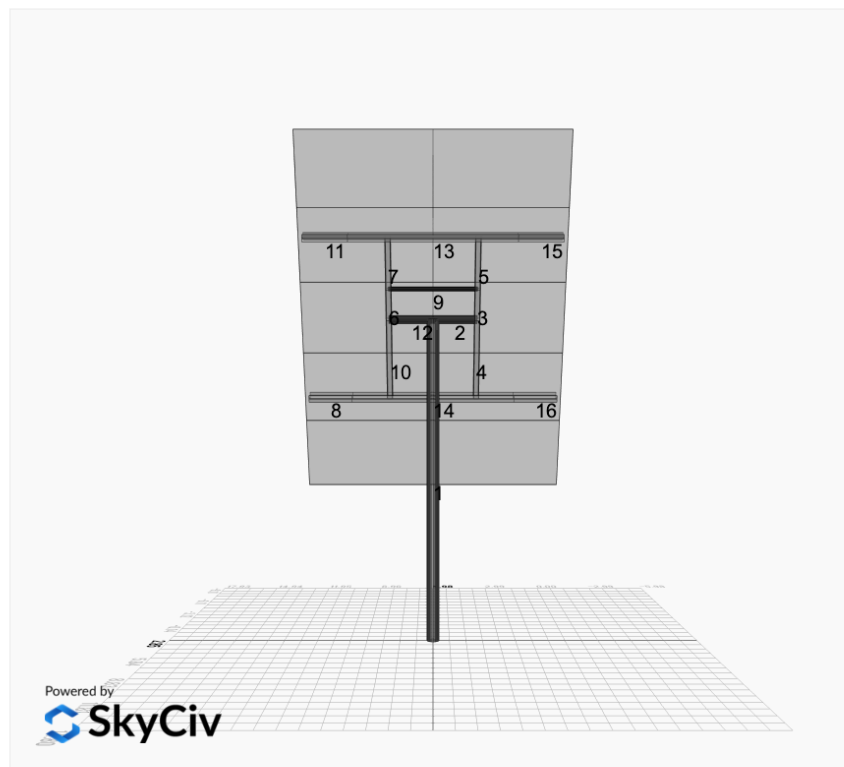

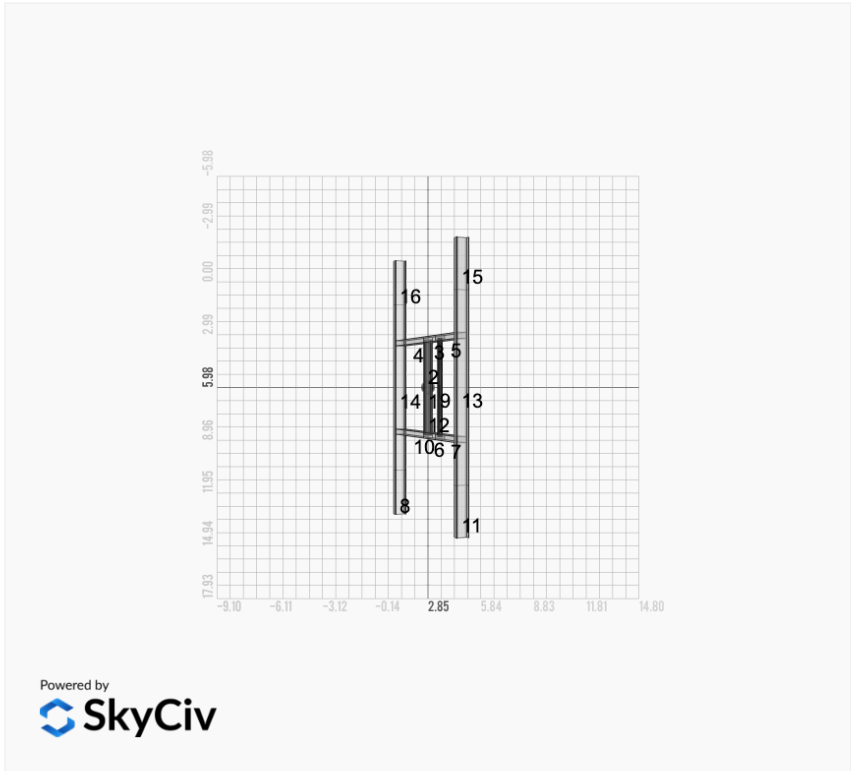

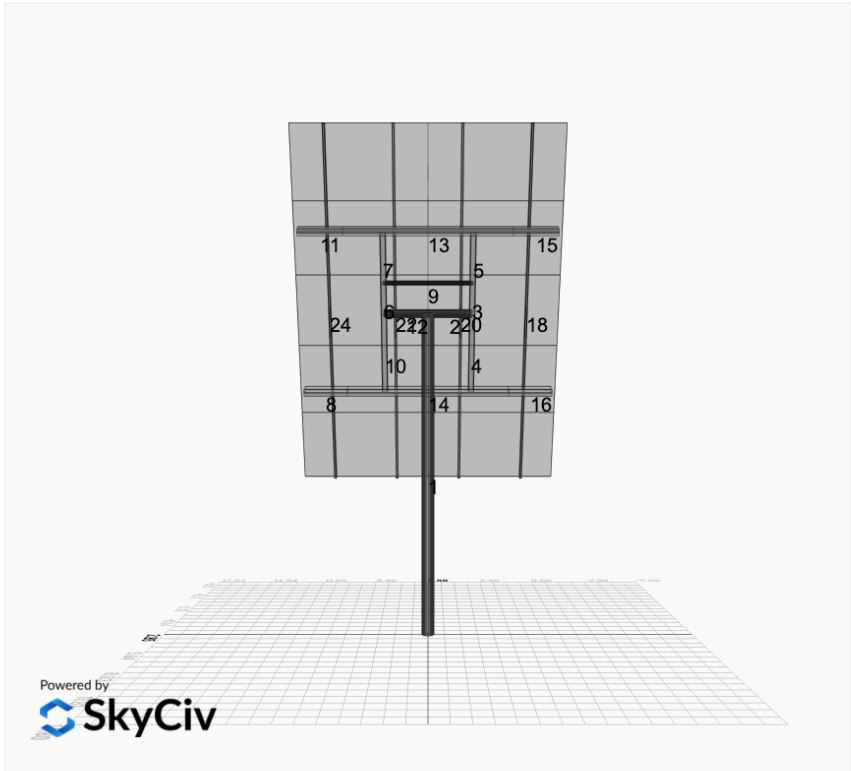
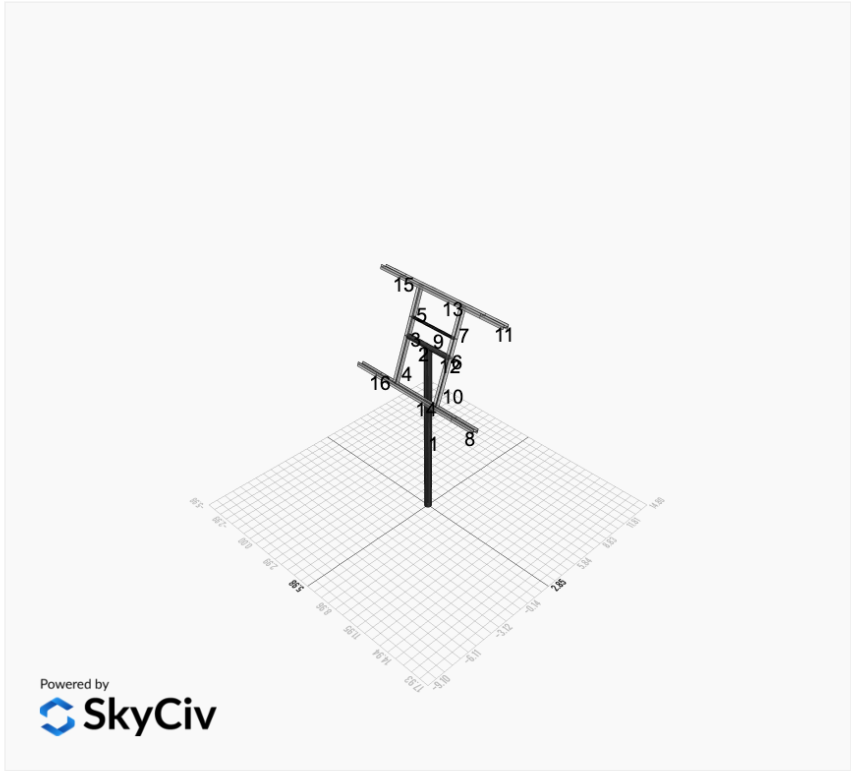

FEM Results (Envelope Worst Case for each member)

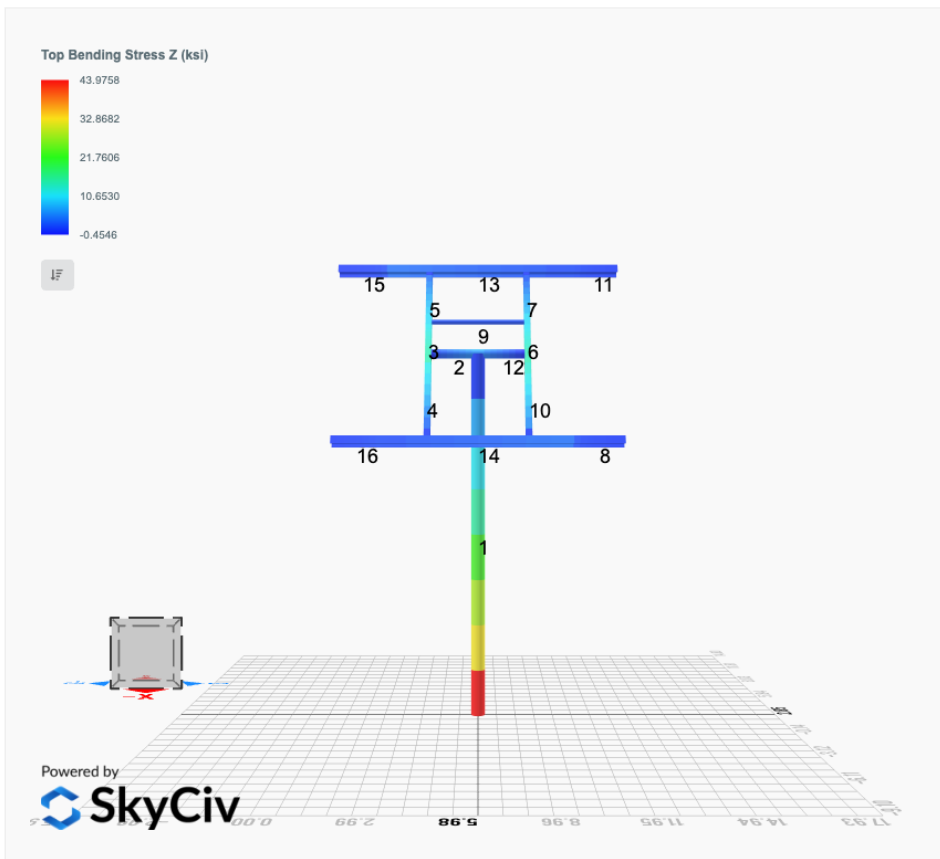
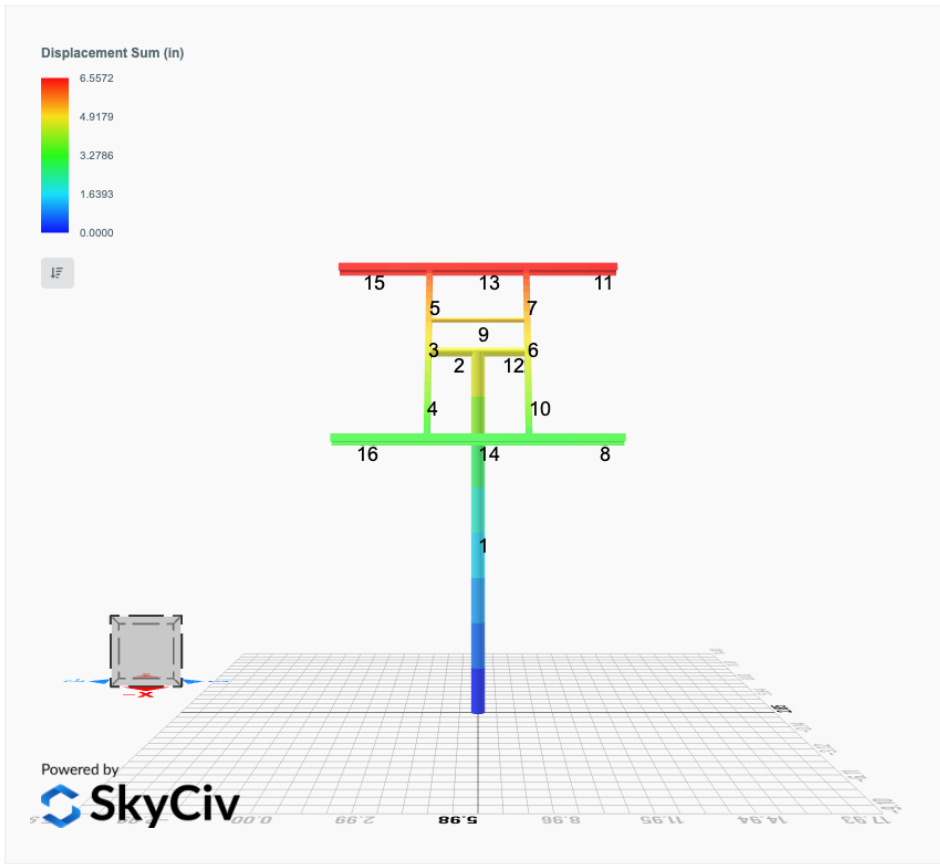

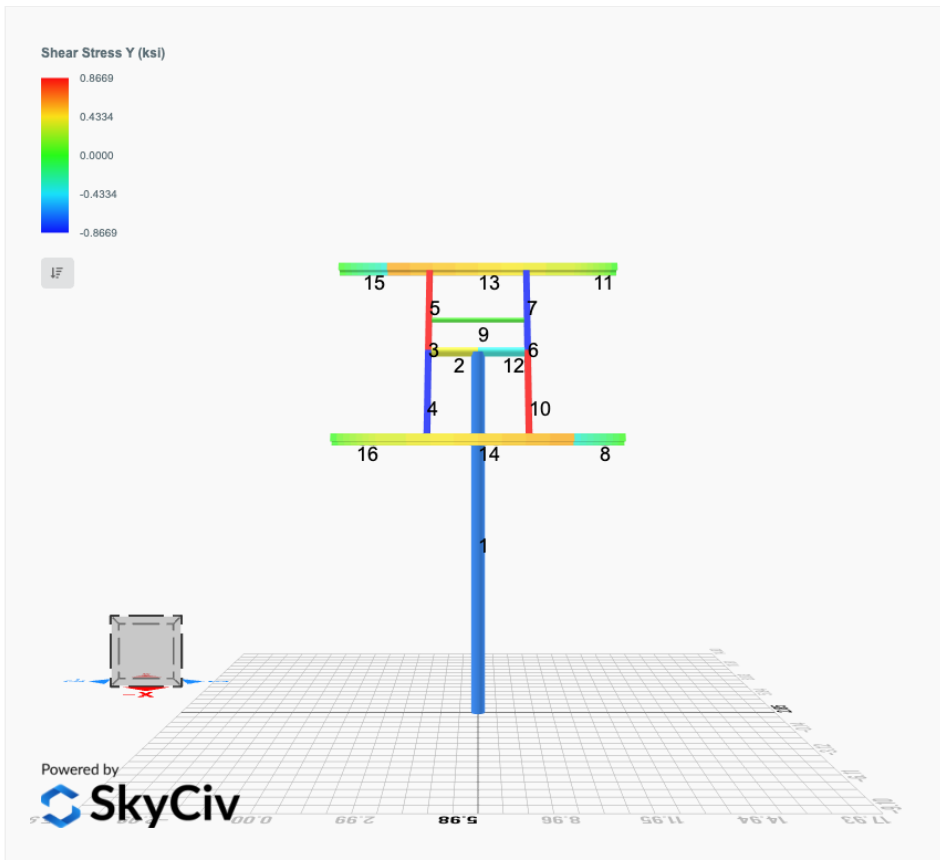
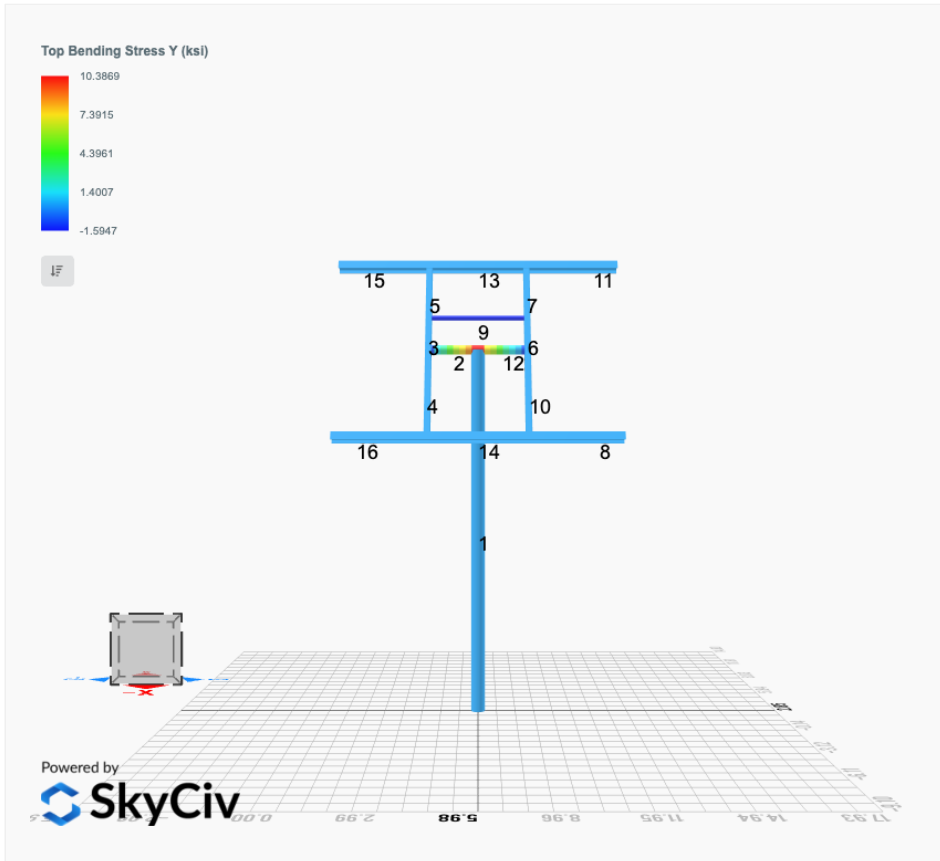

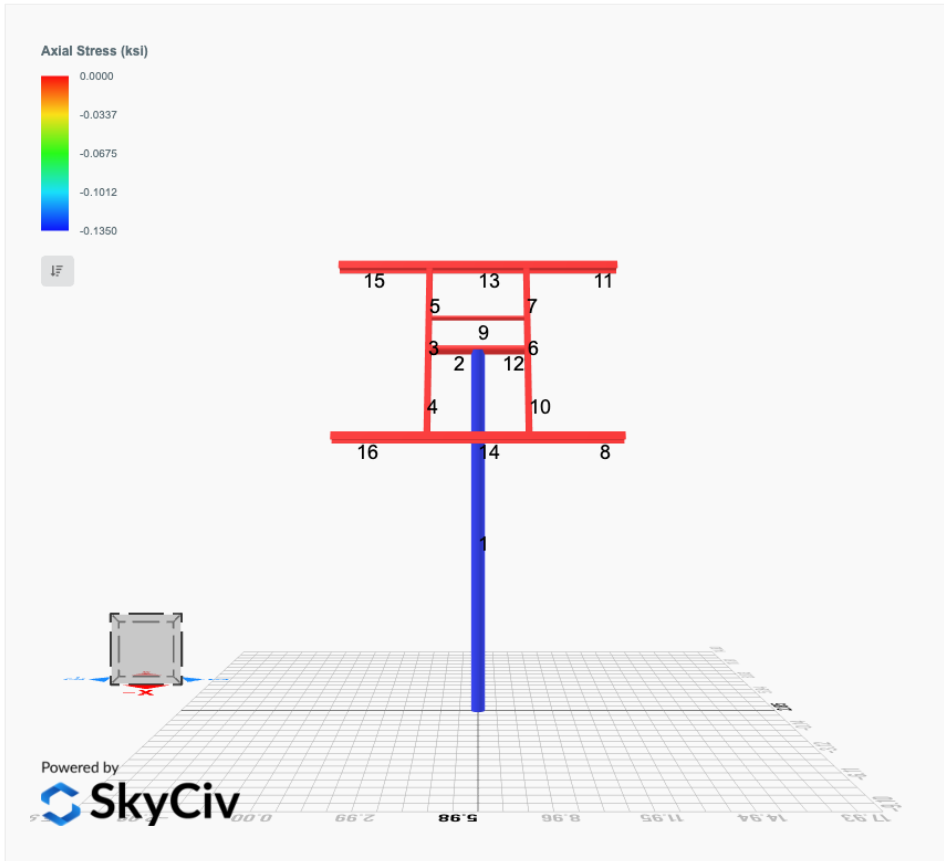

Reaction Forces for Foundation 1 (Node ID#1), (kip, kip-ft)

ASD Load Combination Results

Name	Fx	Fy	Fz	Mx	My	Mz
ULS: 1. D	-0.0000	1.7113	-0.0000	0.0000	-0.0000	0.0083
ULS: 2. D + L	-0.0000	1.7113	-0.0000	0.0000	-0.0000	0.0083
ULS: 3. D + (S or Lr or R)	-0.0000	1.7113	-0.0000	0.0000	-0.0000	0.0083
ULS: 3. D + (S or Lr or R)	-0.0000	1.7113	-0.0000	0.0000	-0.0000	0.0083
ULS: 4. D + 0.75L + 0.75(S or Lr or R)	-0.0000	1.7113	-0.0000	0.0000	-0.0000	0.0083
ULS: 4. D + 0.75L + 0.75(S or Lr or R)	-0.0000	1.7113	-0.0000	0.0000	-0.0000	0.0083
ULS: 5b. D + 0.7E	-0.0000	1.7113	-0.0000	0.0000	-0.0000	0.0083
ULS: 6b. D + 0.75L + 0.75(0.7)E + 0.75S	-0.0000	1.7113	-0.0000	0.0000	-0.0000	0.0083
ULS: 8. 0.6D + 0.7E	-0.0000	1.0268	-0.0000	0.0000	-0.0000	0.0050
ULS: 5a. D + 0.6W_Wind downforce Case A only	-1.8704	2.3921	-0.0000	0.0000	-0.0000	27.4521
ULS: 5a. D + 0.6W_Wind downforce Case B only	-0.0000	1.7113	-0.0000	0.0000	-0.0000	0.0083
ULS: 5a. D + 0.6W_Wind uplift Case A only	1.8704	1.0305	-0.0000	0.0000	-0.0000	-26.9034
ULS: 5a. D + 0.6W_Wind uplift Case B only	-0.0000	1.7113	-0.0000	0.0000	-0.0000	0.0083
ULS: 6a. D + 0.75L + 0.75(0.6)W + 0.75(S or Lr or R)_Wind downforce Case A only	-1.4028	2.2219	-0.0000	0.0000	-0.0000	20.5912
ULS: 6a. D + 0.75L + 0.75(0.6)W + 0.75(S or Lr or R)_Wind downforce Case B only	-0.0000	1.7113	-0.0000	0.0000	-0.0000	0.0083
ULS: 6a. D + 0.75L + 0.75(0.6)W + 0.75(S or Lr or R)_Wind uplift Case A only	1.4028	1.2007	-0.0000	0.0000	-0.0000	-20.1755
ULS: 6a. D + 0.75L + 0.75(0.6)W + 0.75(S or Lr or R)_Wind uplift Case B only	-0.0000	1.7113	-0.0000	0.0000	-0.0000	0.0083
ULS: 6a. D + 0.75L + 0.75(0.6)W + 0.75(S or Lr or R)_Wind downforce Case A only	-1.4028	2.2219	-0.0000	0.0000	-0.0000	20.5912
ULS: 6a. D + 0.75L + 0.75(0.6)W + 0.75(S or Lr or R)_Wind downforce Case B only	-0.0000	1.7113	-0.0000	0.0000	-0.0000	0.0083
ULS: 6a. D + 0.75L + 0.75(0.6)W + 0.75(S or Lr or R)_Wind uplift Case A only	1.4028	1.2007	-0.0000	0.0000	-0.0000	-20.1755
ULS: 6a. D + 0.75L + 0.75(0.6)W + 0.75(S or Lr or R)_Wind uplift Case B only	-0.0000	1.7113	-0.0000	0.0000	-0.0000	0.0083
ULS: 7. 0.6D + 0.6W_Wind downforce Case A only	-1.8704	1.7076	-0.0000	0.0000	-0.0000	27.4488
ULS: 7. 0.6D + 0.6W_Wind downforce Case B only	-0.0000	1.0268	-0.0000	0.0000	-0.0000	0.0050
ULS: 7. 0.6D + 0.6W_Wind uplift Case A only	1.8704	0.3460	-0.0000	0.0000	-0.0000	-26.9067
ULS: 7. 0.6D + 0.6W_Wind uplift Case B only	-0.0000	1.0268	-0.0000	0.0000	-0.0000	0.0050

Worst Case Reactions LRFD

These calculations are taken directly from the FEA via SkyCiv and are used in the Concrete Checks of the Foundation Module.
Note: Worst case values are assumed as downforce wind load cases.

Result	Value
Axial	3.1882
Shear X	-3.1174
Shear Z	-0.0000
Moment X	0.0000
Moment Z	46.6090

Worst Case Reactions ASD

These results are taken from the worst case values in the above table and are used in the Soil Checks in the Foundation Module.
Note: Worst case values are assumed as downforce wind load cases.

Result	Value
Axial	2.3921
Shear X	-1.8704
Shear Z	-0.0000
Moment X	0.0000
Moment Z	27.4521

Project Details

Design Code: AISC 360-16 LRFD
 Provision: LRFD
 Country: United States

User Name: sales@mtsolar.us
 Project Name: 201 FOX STAGE 1_rev.cu.a
 Unit System: imperial



Design Input Information

Design Factors			
Φ_t	Φ_c	Φ_b	Φ_v
0.9	0.9	0.9	0.9

Design Materials			
ID	E (ksi)	F _y (ksi)	F _u (ksi)
1	29000	50	65

Section Dimensions							

ID	Name	d (in)	t _w (in)				
1	2in Pipe Sch 40	2.38	0.15				
4	4in Pipe Sch 40	4.50	0.24				
8	6in Pipe Sch 80	6.63	0.43				

--	--	--	--	--	--	--	--

ID	Name	d (in)	b (in)	t _w (in)	t _b (in)	r (in)	
15	HSS5x3x1/8	5.00	3.00	0.12	0.12	0.12	

--	--	--	--	--	--	--	--

ID	Name	d (in)	t _w (in)	b _t (in)	b _b (in)	t _t (in)	t _b (in)	r (in)
18	W6x9	5.90	0.17	3.94	3.94	0.21	0.21	0.25

Section Properties								
ID	Name	A (in ²)	J (in ⁴)	I _{yp} (in ⁴)	I _{zp} (in ⁴)	I _w (in ⁶)	S _{yp} (in ³)	S _{zp} (in ³)
1	2in Pipe Sch 40	1.07	1.33	0.67	0.67	0.00	0.76	0.76
4	4in Pipe Sch 40	3.17	14.47	7.23	7.23	0.00	4.31	4.31

8	6in Pipe Sch 80	8.40	80.98	40.49	40.49	0.00	16.60	16.60
15	HSS5x3x1/8	1.77	6.02	2.75	6.03	152.35	2.07	2.93
18	W6x9	2.68	0.04	2.20	16.40	17.70	1.72	6.23

Member Properties								
Member ID	Section ID	K _z L (ft)	K _y L (ft)	L _b (ft)	C _b	L	L	L
						S	S	D
						T	C	
1	8	30.51	30.51	14.53	-	300	200	1
2	4	2.00	2.00	2.00	-	300	200	1
3	15	1.42	1.42	1.42	1.19,1.19,1.19,1.19,1.19,1.19,1.18,1.19,1.18,1.19,1.18,1.19,1.18,1.19,1.18,1.19,1.17,1.19,1.18,1.19,1.17,1.19,1.19	300	200	1
4	15	3.75	3.75	3.75	1.69,1.69,1.69,1.69,1.69,1.69,1.67,1.69,1.66,1.69,1.67,1.69,1.66,1.69,1.67,1.69,1.66,1.69,1.67,1.69,1.66,1.69,1.67,1.69,1.66,1.69,1.67,1.69,1.66,1.69	300	200	1
5	15	2.33	2.33	2.33	1.68,1.68,1.68,1.68,1.68,1.68,1.67,1.68,1.66,1.68,1.67,1.68,1.66,1.68,1.67,1.68,1.66,1.68,1.67,1.68,1.66,1.68,1.67,1.68,1.66,1.68,1.67,1.68	300	200	1
6	15	1.42	1.42	1.42	1.19,1.19,1.19,1.19,1.19,1.19,1.18,1.19,1.18,1.19,1.18,1.19,1.18,1.19,1.18,1.19,1.17,1.19,1.18,1.19,1.17,1.19,1.19	300	200	1
7	15	2.33	2.33	2.33	1.68,1.68,1.68,1.68,1.68,1.68,1.67,1.68,1.66,1.68,1.67,1.68,1.66,1.68,1.67,1.68,1.66,1.68,1.67,1.68,1.66,1.68,1.67,1.68,1.66,1.68,1.67,1.68	300	200	1
8	18	2.00	2.00	2.00	2.33,2.33	300	200	1
9	1	4.00	4.00	4.00	-	300	200	1
10	15	3.75	3.75	3.75	1.69,1.69,1.69,1.69,1.69,1.69,1.67,1.69,1.66,1.69,1.67,1.69,1.66,1.69,1.67,1.69,1.66,1.69,1.67,1.69,1.66,1.69,1.67,1.69,1.66,1.69,1.67,1.69,1.66,1.69	300	200	1
11	18	2.00	2.00	2.00	2.33,2.33	300	200	1
12	4	2.00	2.00	2.00	-	300	200	1
13	18	1.75	1.75	1.75	1.48,1.48	300	200	1
14	18	1.75	1.75	1.75	1.48,1.48	300	200	1
15	18	2.00	2.00	2.00	2.33,2.33	300	200	1
16	18	2.00	2.00	2.00	2.33,2.33	300	200	1
17	18	4.00	4.00	4.00	1.21,1.21	300	200	1
18	18	1.75	1.75	1.75	1.48,1.48	300	200	1
19	18	4.00	4.00	4.00	1.20,1.20	300	200	1
20	18	1.75	1.75	1.75	1.48,1.48	300	200	1

Member Design Capacity

Member ID	Φ _t P _n (kip)	Φ _c P _n (kip)	Φ _b M _{zn} (k-ft)	Φ _b M _{yn} (k-ft)	Φ _v V _{yn} (kip)	Φ _v V _{zn} (kip)
1	378.22	68.24	62.23	62.23	113.47	113.47

2	142.83	140.22	16.17	16.17	42.85	42.85
3	79.65	73.55	10.99	4.60	29.14	16.61
4	79.65	68.91	10.99	4.60	29.14	16.61
5	79.65	72.20	10.99	4.60	29.14	16.61
6	79.65	73.55	10.99	4.60	29.14	16.61
7	79.65	72.20	10.99	4.60	29.14	16.61
8	120.60	114.57	23.36	6.45	30.09	45.74
9	48.35	36.84	2.85	2.85	14.51	14.51
10	79.65	68.91	10.99	4.60	29.14	16.61
11	120.60	114.57	23.36	6.45	30.09	45.74
12	142.83	140.22	16.17	16.17	42.85	42.85
13	120.60	115.95	23.36	6.45	30.09	45.74
14	120.60	115.95	23.36	6.45	30.09	45.74
15	120.60	114.57	23.36	6.45	30.09	45.74
16	120.60	114.57	23.36	6.45	30.09	45.74
17	120.60	98.23	23.36	6.45	30.09	45.74
18	120.60	115.95	23.36	6.45	30.09	45.74
19	120.60	98.23	23.36	6.45	30.09	45.74
20	120.60	115.95	23.36	6.45	30.09	45.74

Design Ratio

Member ID	P	M _z	M _y	V _y	V _z	(P,M _z ,M _y)	Worst LC	KL/r	δ	Status
1	0.047	0.749	0.000	0.027	0.000	0.772	#13	0.834	Not Required	Pass
2	0.000	0.125	0.180	0.031	0.036	0.305	#13	0.079	Not Required	Pass
3	0.006	0.330	0.073	0.033	0.013	0.395	#13	0.068	Not Required	Pass
4	0.005	0.329	0.064	0.033	0.009	0.384	#13	0.120	Not Required	Pass
5	0.005	0.205	0.063	0.033	0.008	0.213	#13	0.112	Not Required	Pass
6	0.006	0.331	0.073	0.033	0.013	0.395	#13	0.068	Not Required	Pass
7	0.005	0.205	0.063	0.033	0.008	0.213	#13	0.112	Not Required	Pass
8	0.000	0.014	0.020	0.011	0.003	0.032	#13	Not Required	Not Required	Pass
9	0.002	0.012	0.031	0.001	0.000	0.042	#13	0.203	Not Required	Pass
10	0.005	0.329	0.064	0.033	0.009	0.384	#13	0.120	Not Required	Pass
11	0.000	0.014	0.020	0.011	0.003	0.032	#13	Not Required	Not Required	Pass
12	0.000	0.125	0.180	0.031	0.036	0.305	#13	0.079	Not Required	Pass
13	0.000	0.050	0.072	0.021	0.005	0.111	#13	Not Required	Not Required	Pass
14	0.000	0.050	0.072	0.021	0.005	0.111	#13	Not Required	Not Required	Pass
15	0.000	0.014	0.020	0.011	0.003	0.032	#13	Not Required	Not Required	Pass
16	0.000	0.014	0.020	0.011	0.003	0.032	#13	Not Required	Not Required	Pass
17	0.001	0.056	0.027	0.011	0.003	0.079	#13	0.177	Not Required	Pass
18	0.000	0.050	0.072	0.021	0.005	0.111	#13	Not Required	Not Required	Pass
19	0.002	0.057	0.026	0.011	0.003	0.080	#13	0.265	Not Required	Pass
20	0.000	0.050	0.072	0.021	0.005	0.111	#13	Not Required	Not Required	Pass

Definitions

Φ_t	Safety factor for tensile
Φ_c	Safety factor for compression
Φ_b	Safety factor for flexure
Φ_v	Safety factor for shear
E	Modulus of elasticity
F _y	Specified minimum yield stress
F _u	Specified minimum tensile strength
A	Cross-sectional area
I	Torsional constant

J	Torsional constant
I_{yp}	Moment of inertia about the Y axes
I_{zp}	Moment of inertia about the Z axes
I_w	Warping constant
S_{yp}	Plastic section modulus about the Y axis
S_{zp}	Plastic section modulus about the Z axis
KL	Effective length
C_b	Buckling modification factor (from all load combinations)
L_b	Length between braced points
LST	Limited slenderness for tension
LSC	Limited slenderness for compression
LD	Limited deflection
P_n	Nominal axial strength (tension/compression)
M_n	Nominal flexural strength (about Z/Y axis)
V_n	Nominal shear strength (along Z/Y axis)
P	Design ratio in case of axial force
M_z	Design ratio in case of bending about Z axis
M_y	Design ratio in case of bending about Y axis
V_y	Design ratio in case of shear along Y axis
V_z	Design ratio in case of shear along Z axis
(P, M_z , M_y)	Design ratio in case of axial force and bending action
KL/r	Design ratio in case of section slenderness
δ	Design ratio in case of member deflection
OK	Capacity is provided
NG	Capacity is not provided

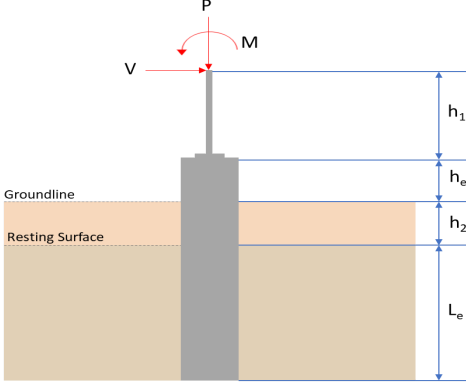
REFERENCES	CALCULATIONS	RESULTS																										
	<p>SkyCiv Foundation Design Pile Foundation</p> <p>Design Information : Design code : IBC 2021 (International Building Code) Unit System : Imperial</p>																											
	<p>Pile Input</p>  <p>Geometry Pile shape: rectangular $b = 48$ in - Pile width $D = 48$ in - Pile depth $L = 6.5$ ft - Total pile length $h_1 = 0$ ft - Lateral load height from the top of the pile, $h_2 = 0$ ft - Depth to resting surface $h_e = 0$ ft - Length of pile above the ground</p> <p>Tabulation of Soil Parameters</p> <table border="1" data-bbox="416 1102 1193 1191"> <thead> <tr> <th>Layer</th> <th>Label</th> <th>Allowable Bearing Pressure (q_a) (psf)</th> <th>Allowable Lateral Pressure (R) (psf/ft)</th> </tr> </thead> <tbody> <tr> <td>1</td> <td>Sand, silty sand, clayey sand, silty gravel & clayey gravel</td> <td>2000.000</td> <td>150.000</td> </tr> </tbody> </table> <p>Tabulation of Loads</p> <table border="1" data-bbox="676 1288 935 1458"> <thead> <tr> <th>Load Component</th> <th>ASD</th> <th>LRFD</th> </tr> </thead> <tbody> <tr> <td>P (kip)</td> <td>2.392</td> <td>3.188</td> </tr> <tr> <td>V_x (kip)</td> <td>-1.870</td> <td>-3.117</td> </tr> <tr> <td>V_z (kip)</td> <td>0.000</td> <td>0.000</td> </tr> <tr> <td>M_x (kipft)</td> <td>0.000</td> <td>0.000</td> </tr> <tr> <td>M_z (kipft)</td> <td>27.452</td> <td>46.609</td> </tr> </tbody> </table> <p>Material Properties $f'_{ck} = 3$ ksi - Concrete strength,</p>	Layer	Label	Allowable Bearing Pressure (q_a) (psf)	Allowable Lateral Pressure (R) (psf/ft)	1	Sand, silty sand, clayey sand, silty gravel & clayey gravel	2000.000	150.000	Load Component	ASD	LRFD	P (kip)	2.392	3.188	V_x (kip)	-1.870	-3.117	V_z (kip)	0.000	0.000	M_x (kipft)	0.000	0.000	M_z (kipft)	27.452	46.609	
Layer	Label	Allowable Bearing Pressure (q_a) (psf)	Allowable Lateral Pressure (R) (psf/ft)																									
1	Sand, silty sand, clayey sand, silty gravel & clayey gravel	2000.000	150.000																									
Load Component	ASD	LRFD																										
P (kip)	2.392	3.188																										
V_x (kip)	-1.870	-3.117																										
V_z (kip)	0.000	0.000																										
M_x (kipft)	0.000	0.000																										
M_z (kipft)	27.452	46.609																										
	<p>Required depth to resist lateral loads (ASD) H - Point of application of the lateral load</p> $H = h_1 + h_2 + h_e$ $H = (0 \text{ ft}) + (0 \text{ ft}) + (0 \text{ ft})$ $H = 0 \text{ ft}$ <p>Considering x-direction: H_o - Lateral force per length of pile,</p> $H_o = \frac{V_x}{1.57 D}$ $H_o = \frac{(-1.87 \text{ kip})}{1.57 \times (48 \text{ in})}$ $H_o = -0.29777 \text{ kip/ft}$ <p>M_o - Moment per length of pile,</p> $M_o = \frac{M_z + (V_x H)}{1.57 D}$																											

	$M_o = \frac{(27.452 \text{ kipft}) + ((-1.87 \text{ kip}) \times (0 \text{ ft}))}{1.57 \times (48 \text{ in})}$ $M_o = 4.3713 \text{ kipft/ft}$ <p>Required depth of embedment in earth:</p> $L_x^3 - \left(14.14 \times \frac{H_o \times L_x}{R}\right) - \left(18.85 \times \frac{M_o}{R}\right) = 0$ <p>Solving the cubic equation: $L_{e,x} = 6.2046 \text{ ft}$ - Required depth in x-direction,</p> <p>Considering z-direction: $L_{e,z} = 0 \text{ ft}$ - Required depth in z-direction,</p> <p>Minimum embedded depth required: $L_{e,req}$ - Depth of pile required,</p> $L_{e,req} = \text{MAX}[L_{e,x}, L_{e,z}]$ $L_{e,req} = \text{MAX}[(6.2046 \text{ ft}), (0 \text{ ft})]$ $L_{e,req} = 6.205 \text{ ft}$ <p>L_e - Actual embedded length of pile,</p> $L_e = L - h_e - h_2$ $L_e = (6.5 \text{ ft}) - (0 \text{ ft}) - (0 \text{ ft})$ $L_e = 6.5 \text{ ft}$ <p><i>Ratio</i> - Embedded depth</p> $\text{Ratio} = \frac{L_{e,req}}{L_e}$ $\text{Ratio} = \frac{(6.205 \text{ ft})}{(6.5 \text{ ft})}$ $\text{Ratio} = 0.95462$	<p>Status: PASS Ratio: 0.950</p>
	<p>End-bearing Capacity (ASD)</p> <p>A - Pile cross-section area</p> $A = b D$ $A = (48 \text{ in}) \times (48 \text{ in})$ $A = 16 \text{ ft}^2$ <p>q - End-bearing pressure</p> $q = \frac{P_v}{A}$ $q = \frac{(2.392 \text{ kip})}{(16 \text{ ft}^2)}$ $q = 0.1495 \text{ kip/ft}^2$ <p>Check bearing capacity ratio:</p> <p><i>Ratio</i> - Capacity</p> $\text{Ratio} = \frac{q}{q_o}$ $\text{Ratio} = \frac{(0.1495 \text{ kip/ft}^2)}{(2000 \text{ psf})}$ $\text{Ratio} = 0.07475$	<p>Status: PASS Ratio: 0.070</p>
<p>Czerniak</p>	<p>Lateral Soil Pressure (ASD):</p> <p>L/D - Length to least lateral dimension ratio,</p> $L/D = \frac{L}{D}$ $L/D = \frac{(6.5 \text{ ft})}{(48 \text{ in})}$	

$$L/D = 1.625$$

Since $L/D \leq 10$,

Pile is short.

Considering x-direction:

$H_o = -0.29777$ kip/ft - Lateral force per length of pile,

$M_o = 4.3713$ kipft/ft - Overturning moment per length of pile,

a - Distance from resting surface to pivot point,

$$a = \frac{(4 M_o L_e) + (3 H_o L_e^2)}{(6 M_o) + (4 H_o L_e)}$$

$$a = \frac{(4 \times (4.3713 \text{ kipft/ft}) \times (6.5 \text{ ft})) + (3 \times (-0.29777 \text{ kip/ft}) \times (6.5 \text{ ft})^2)}{(6 \times (4.3713 \text{ kipft/ft})) + (4 \times (-0.29777 \text{ kip/ft}) \times (6.5 \text{ ft}))}$$

$$a = 4.4568 \text{ ft}$$

p - Earth pressure against the pile at distance $a/2$ from resting surface,

$$p = \frac{0.75 [(4 M_o) + (3 H_o L_e)]^2}{L_e^2 [(3 M_o) + (2 H_o L_e)]}$$

$$p = \frac{0.75 \times [(4 \times (4.3713 \text{ kipft/ft})) + (3 \times (-0.29777 \text{ kip/ft}) \times (6.5 \text{ ft}))]^2}{(6.5 \text{ ft})^2 \times [(3 \times (4.3713 \text{ kipft/ft})) + (2 \times (-0.29777 \text{ kip/ft}) \times (6.5 \text{ ft}))]}$$

$$p = 0.26195 \text{ kip/ft}^2$$

s - Earth pressure against the pile at distance L_e ,

$$s = \frac{6 [(2 M_o) + (H_o L_e)]}{L_e^2}$$

$$s = \frac{6 \times [(2 \times (4.3713 \text{ kipft/ft})) + ((-0.29777 \text{ kip/ft}) \times (6.5 \text{ ft}))]}{(6.5 \text{ ft})^2}$$

$$s = 0.9667 \text{ kip/ft}^2$$

Check lateral soil pressure capacity:

p_a - Allowable lateral soil pressure at depth $a/2$,

$$p_a = R \frac{a}{2}$$

$$p_a = (150 \text{ psf/ft}) \times \frac{(4.4568 \text{ ft})}{2}$$

$$p_a = 0.33426 \text{ kip/ft}^2$$

Ratio - Lateral soil capacity

$$\text{Ratio} = \frac{p}{p_a}$$

$$\text{Ratio} = \frac{(0.26195 \text{ kip/ft}^2)}{(0.33426 \text{ kip/ft}^2)}$$

$$\text{Ratio} = 0.78368$$

p_s - Allowable lateral soil pressure at depth L_e ,

$$p_s = R L_e$$

$$p_s = (150 \text{ psf/ft}) \times (6.5 \text{ ft})$$

$$p_s = 0.975 \text{ kip/ft}^2$$

Ratio - Lateral soil capacity

$$\text{Ratio} = \frac{s}{p_s}$$

$$\text{Ratio} = \frac{(0.9667 \text{ kip/ft}^2)}{(0.975 \text{ kip/ft}^2)}$$

$$\text{Ratio} = 0.9915$$

Status: **PASS**
Ratio: **0.780**

Status: **PASS**
Ratio: **0.990**

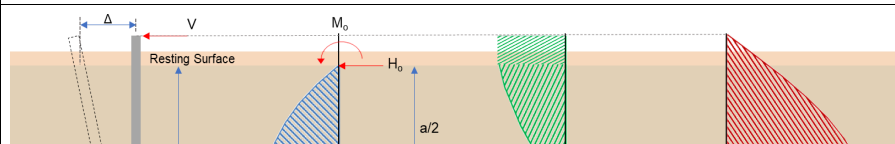

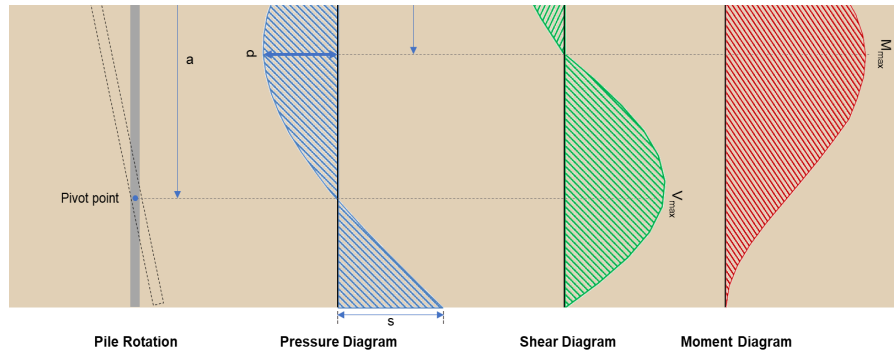

Shear force and Bending moment (x-direction, LRFD)

H_o - Lateral force per length of pile,

$$H_o = \frac{V_e}{1.57 D}$$

$$H_o = \frac{(-3.117 \text{ kip})}{1.57 \times (48 \text{ in})}$$

$$H_o = -0.49634 \text{ kip/ft}$$

M_o - Moment per length of pile,

$$M_o = \frac{M_e + (V_e H)}{1.57 D}$$

$$M_o = \frac{(46.609 \text{ kipft}) + ((-3.117 \text{ kip}) \times (0 \text{ ft}))}{1.57 \times (48 \text{ in})}$$

$$M_o = 7.4218 \text{ kipft/ft}$$

E - Distance from lateral load to resisting surface,

$$E = \frac{M_o}{H_o}$$

$$E = \frac{(7.4218 \text{ kipft/ft})}{(-0.49634 \text{ kip/ft})}$$

$$E = 14.953 \text{ ft}$$

a - Distance from resting surface to pivot point,

$$a = \frac{(4 M_o L_e) + (3 H_o L_e^2)}{(6 M_o) + (4 H_o L_e)}$$

$$a = \frac{(4 \times (7.4218 \text{ kipft/ft}) \times (6.5 \text{ ft})) + (3 \times (-0.49634 \text{ kip/ft}) \times (6.5 \text{ ft})^2)}{(6 \times (7.4218 \text{ kipft/ft})) + (4 \times (-0.49634 \text{ kip/ft}) \times (6.5 \text{ ft}))}$$

$$a = 4.455 \text{ ft}$$

V_{max} - Max shear force located at depth a ,

$$V_{max} = (H_o D) \left[1 - \left[3 \left(\frac{4 E}{L_e} + 3 \right) \left(\frac{a}{L_e} \right)^2 \right] + \left[4 \left(\frac{3 E}{L_e} + 2 \right) \left(\frac{a}{L_e} \right)^3 \right] \right]$$

$$V_{max} = ((-0.49634 \text{ kip/ft}) \times (48 \text{ in})) \times \left[1 - \left[3 \times \left(\frac{4 \times (14.953 \text{ ft})}{(6.5 \text{ ft})} + 3 \right) \times \left(\frac{(4.455 \text{ ft})}{(6.5 \text{ ft})} \right)^2 \right] + \left[4 \times \left(\frac{3 \times (14.953 \text{ ft})}{(6.5 \text{ ft})} + 2 \right) \times \left(\frac{(4.455 \text{ ft})}{(6.5 \text{ ft})} \right)^3 \right] \right]$$

$$V_{max} = 9.3946 \text{ kip}$$

M_{max} - Max bending moment located at depth $a/2$,

$$M_{max} = (H_o D L_e) \left[\left(\frac{E}{L_e} + \frac{a}{2 L_e} \right) - \left[\left(\frac{4 E}{L_e} + 3 \right) \left(\frac{a}{2 L_e} \right)^3 \right] + \left[\left(\frac{3 E}{L_e} + 2 \right) \left(\frac{a}{2 L_e} \right)^4 \right] \right]$$

$$M_{max} = ((-0.49634 \text{ kip/ft}) \times (48 \text{ in}) \times (6.5 \text{ ft})) \times \left[\left(\frac{(14.953 \text{ ft})}{(6.5 \text{ ft})} + \frac{(4.455 \text{ ft})}{2 \times (6.5 \text{ ft})} \right) - \left[\left(\frac{4 \times (14.953 \text{ ft})}{(6.5 \text{ ft})} + 3 \right) \times \left(\frac{(4.455 \text{ ft})}{2 \times (6.5 \text{ ft})} \right)^3 \right] + \left[\left(\frac{3 \times (14.953 \text{ ft})}{(6.5 \text{ ft})} + 2 \right) \times \left(\frac{(4.455 \text{ ft})}{2 \times (6.5 \text{ ft})} \right)^4 \right] \right]$$

$$M_{max} = 29.357 \text{ kipft}$$

Minimum Reinforcement Check (LRFD)

Parameters:

$f'_{ck} = 3 \text{ ksi}$ - Concrete strength,
 $f_{yk} = 60 \text{ ksi}$ - Longitudinal reinforcement strength,
 $\phi = 0.65$ - Reduction factor for axial strength,
 $\alpha = 0.8$ - Alpha factor for axial strength,
 $A_g = 2304 \text{ in}^2$ - Gross area of concrete,

Table 22.4.2.1

Longitudinal reinforcement:

Required reinforcement due to axial load, $A_{st,required}$

22.4.2.2, 10.6.1.1

$A_{st,required}$

$$A_{st,required} = \text{Min} \left[\frac{\frac{P}{\phi \alpha} - (0.85 f'_{ck} A_g)}{f_{yk} - (0.85 f'_{ck})}, (0.08 A_g) \right]$$

$$A_{st,required} = \text{Min} \left[\frac{\frac{(3.188 \text{ kip})}{(0.65) \times (0.8)} - (0.85 \times (3 \text{ ksi}) \times (2304 \text{ in}^2))}{(60 \text{ ksi}) - (0.85 \times (3 \text{ ksi}))}, (0.08 \times (2304 \text{ in}^2)) \right]$$

$$A_{st,required} = -102.16 \text{ in}^2$$

A_{min} - Governing minimum reinforcement area,

$$A_{min} = \text{Max} [A_{st,required}, (0.0018 A_g)]$$

$$A_{min} = \text{Max} [(-102.16 \text{ in}^2), (0.0018 \times (2304 \text{ in}^2))]$$

$$A_{min} = 4.1472 \text{ in}^2$$

n_{rebar} - Required number of reinforcement,

$$n_{rebar} = \frac{A_{min}}{A_{rebar}}$$

$$n_{rebar} = \frac{(4.1472 \text{ in}^2)}{(0.3068 \text{ in}^2)}$$

$$n_{rebar} = 14$$

A_{st} - Actual total reinforcement area,

$$A_{st} = n_{rebar} \frac{\pi d_{bar}^2}{4}$$

$$A_{st} = (14) \times \frac{\pi \times (0.625 \text{ in})^2}{4}$$

$$A_{st} = 4.2951 \text{ in}^2$$

Ratio - Capacity

$$\text{Ratio} = \frac{A_{min}}{A_{st}}$$

$$\text{Ratio} = \frac{(4.1472 \text{ in}^2)}{(4.2951 \text{ in}^2)}$$

$$\text{Ratio} = 0.96556$$

Status: **PASS**
Ratio: **0.970**

25.2.3

s_{rebar} - Minimum spacing of reinforcement,

$$s_{rebar} = \text{Max} [1.5, (1.5 d_{bar})]$$

$$s_{rebar} = \text{Max} [1.5, (1.5 \times (0.625 \text{ in}))]$$

$$s_{rebar} = 1.5 \text{ in}$$

Ties:

25.7.2.2 Since longitudinal reinforcement is \leq No. 10 \emptyset : Use #3(0.375 in)

25.7.2.1 s_{ties} - Maximum spacing of ties,

$$s_{ties} = \text{Min} [(16 d_{bar}), (48 d_{ties}), \text{Min} (D, b)]$$

$$s_{ties} = \text{Min} [(16 \times (0.625 \text{ in})), (48 \times (0.375 \text{ in})), \text{Min} ((48 \text{ in}), (48 \text{ in}))]$$

$$s_{ties} = 10 \text{ in}$$

Summary:

Main reinforcement: **14 - #5 (0.625 in)**

Axial Compression Strength (ACI 318-19, LRFD)22.4.2.2 ϕP_N - Allowable axial compressive strength

$$\phi P_N = \phi 0.80 [(0.85 f'_{ck} [A_g - A_{st}]) + (f_{yk} A_{st})]$$

$$\phi P_N = (0.65) \times 0.80 \times [(0.85 \times (3 \text{ ksi}) \times [(2304 \text{ in}^2) - (4.2951 \text{ in}^2)]) + ((60 \text{ ksi}) \times (4.2951 \text{ in}^2))]$$

$$\phi P_N = 3183.4 \text{ kip}$$

Ratio - Capacity

$$\text{Ratio} = \frac{P}{\phi P_N}$$

$$\text{Ratio} = \frac{(3.188 \text{ kip})}{(3183.4 \text{ kip})}$$

$$\text{Ratio} = 0.0010014$$

Status: **PASS**
Ratio: **0.000****Shear Strength (ACI 318-19, LRFD)****Parameters:** $b_w = 48 \text{ in}$ - Effective width,22.5.2.2 d - Effective depth

$$d = 0.80 D$$

$$d = 0.80 \times (48 \text{ in})$$

$$d = 38.4 \text{ in}$$

22.5.5.1.3 λ_s - size effect modification factor

$$\lambda_s = \text{MIN} \left[\sqrt{\frac{2}{1 + \frac{d}{10}}}, 1 \right]$$

$$\lambda_s = \text{MIN} \left[\sqrt{\frac{2}{1 + \frac{(38.4 \text{ in})}{10}}}, 1 \right]$$

$$\lambda_s = 0.64282$$

The following variables were converted to be consistent with empirical formula $f'_{ck} = 3 \text{ ksi} \rightarrow 3000 \text{ psi}$,22.5.5.1.1 $V_{c,max}$ - Max shear strength of concrete

$$V_{c,max} = 5 \lambda_s \sqrt{f'_{ck}} b_w d$$

$$V_{c,max} = 5 \times (0.64282) \times \sqrt{(3000 \text{ psi})} \times (48 \text{ in}) \times (38.4 \text{ in})$$

$$V_{c,max} = 324.49 \text{ kip}$$

The following variables were converted to be consistent with empirical formula $f'_{ck} = 3 \text{ ksi} \rightarrow 3000 \text{ psi}$, $P = 3.188 \text{ kip} \rightarrow 3188 \text{ lbf}$,22.5.5.1.1(a) $V_{c,a}$ - Shear strength of concrete (a)

$$V_{c,a} = \left[2 \lambda_s \sqrt{f'_{ck}} + \frac{P}{6 A_g} \right] b_w d$$

$$V_{c,a} = \left[2 \times (0.64282) \times \sqrt{(3000 \text{ psi})} + \frac{(3188 \text{ lbf})}{6 \times (2304 \text{ in}^2)} \right] \times (48 \text{ in}) \times (38.4 \text{ in})$$

$$V_{c,a} = 130.22 \text{ kip}$$

The following variables were converted to be consistent with empirical formula $f'_{ck} = 3 \text{ ksi} \rightarrow 3000 \text{ psi}$,22.5.5.1.2 $V_{c,b}$ - Shear strength of concrete (b)

$$V_{c,b} = \left[2 \lambda_s \sqrt{f'_{ck}} + (0.05 f'_{ck}) \right] b_w d$$

$$V_{c,b} = \left[2 \times (0.64282) \times \sqrt{(3000 \text{ psi})} + (0.05 \times (3000 \text{ psi})) \right] \times (48 \text{ in}) \times (38.4 \text{ in})$$

$$V_{c,b} = 406.27 \text{ kip}$$

 V_c - Governing shear strength of concrete

$$V_c = \text{Min}[V_{c,max}, V_{c,a}, V_{c,b}]$$

$$V_c = \text{Min}[(324.49 \text{ kip}), (130.22 \text{ kip}), (406.27 \text{ kip})]$$

$$V_c = 130.22 \text{ kip}$$

<p>22.5.1.2</p>	<p>The following variables were converted to be consistent with empirical formula $f'_{ck} = 3 \text{ ksi} \rightarrow 3000 \text{ psi}$.</p> <p>$V_{s,a}$ - Shear strength of steel (a)</p> $V_{s,a} = 8 \sqrt{f'_{ck}} b_w d$ $V_{s,a} = 8 \times \sqrt{(3000 \text{ psi})} \times (48 \text{ in}) \times (38.4 \text{ in})$ $V_{s,a} = 807.65 \text{ kip}$ <p>A_v - Ties rebar area,</p> $A_v = \frac{\pi d_{ties}^2}{4}$ $A_v = \frac{\pi \times (0.375 \text{ in})^2}{4}$ $A_v = 0.11045 \text{ in}^2$ <p>22.5.8.5.3 $V_{s,b}$ - Shear strength of steel (b)</p> $V_{s,b} = \frac{2 A_v f_{ywk} d}{s_{ties}}$ $V_{s,b} = \frac{2 \times (0.11045 \text{ in}^2) \times (60 \text{ ksi}) \times (38.4 \text{ in})}{(10 \text{ in})}$ $V_{s,b} = 50.894 \text{ kip}$ <p>V_s - Governing shear strength of steel</p> $V_s = \text{MIN}[V_{s,a}, V_{s,b}]$ $V_s = \text{MIN}[(807.65 \text{ kip}), (50.894 \text{ kip})]$ $V_s = 50.894 \text{ kip}$ <p>22.5.1.1 ϕV_n - Allowable shear strength</p> $\phi V_n = \phi (V_c + V_s)$ $\phi V_n = (0.65) \times ((130.22 \text{ kip}) + (50.894 \text{ kip}))$ $\phi V_n = 117.72 \text{ kip}$ <p>Considering x-direction:</p> <p>$V_{max} = 9.3946 \text{ kip}$ - Maximum shear force in the x-direction, Ratio - Capacity</p> $\text{Ratio} = \frac{V_{max}}{\phi V_n}$ $\text{Ratio} = \frac{(9.3946 \text{ kip})}{(117.72 \text{ kip})}$ $\text{Ratio} = 0.079803$	<p>Status: PASS Ratio: 0.080</p>
<p>14.5.2.1b</p>	<p>Flexural Strength (ACI 318-19, LRFD)</p> <p>S_m - Section modulus</p> $S_m = \frac{b D^2}{6}$ $S_m = \frac{(48 \text{ in}) \times (48 \text{ in})^2}{6}$ $S_m = 18432 \text{ in}^3$ <p>$\lambda = 1$ - Concrete modification factor (Normal concrete), Allowable flexural strength: M_n shall be the lesser of:</p> <p>$\phi M_{n,1}$</p> $\phi M_{n,1} = \phi \times 5 \times \lambda \times \sqrt{f'_c} \times S_m$ $\phi M_{n,1} = 0.65 \times 5 \times 1 \times \sqrt{(3 \text{ ksi})} \times 18432.001 \text{ in}^3$ $\phi M_{n,1} = 273.423 \text{ kip ft}$ <p>$\phi M_{n,2}$</p> $\phi M_{n,2} = 0.85 f'_c S_m$	

$$\phi M_{n,z} = \phi S_x F_y$$

$$\phi M_{n,z} = (0.65) \times 0.85 \times (3 \text{ ksi}) \times (18432 \text{ in}^3)$$

$$\phi M_{n,z} = 2545.9 \text{ kipft}$$

Therefore,

ϕM_n - Allowable flexural strength,

$$\phi M_n = \text{MIN}[\phi M_{n,1}, \phi M_{n,2}]$$

$$\phi M_n = \text{MIN}[(273.42 \text{ kipft}), (2545.9 \text{ kipft})]$$

$$\phi M_n = 273.42 \text{ kipft}$$

Considering x-direction:

$M_{max} = 29.357 \text{ kipft}$ - Maximum moment in the x-direction,

Ratio - Capacity

$$\text{Ratio} = \frac{M_{max}}{\phi M_n}$$

$$\text{Ratio} = \frac{(29.357 \text{ kipft})}{(273.42 \text{ kipft})}$$

$$\text{Ratio} = 0.10737$$

Status: **PASS**
Ratio: **0.110**