

Your Project Calculations



Project Name: DaveM-JB-RevB

S3D Model Link:

https://platform.skyciv.com/structural?preload_name=DaveM-JB-RevB&preload_path=Shared%20Enterprise%20Folder/MT_Solar_Projects/7_2023

Public Model Link:

https://platform.skyciv.com/structural-viewer?project_id=YLsqDr341FU6e7xh7oep0NEXHf4yd8bm0fd0CQzR0LdeZy7FjwAAItN0SbvvCto

Array Specification

Product:	Cyber
Unique ID:	1P-0-6TOP-SD-24-L-3Hx2W-5K50
Duty Classification:	SD
Module Width:	40.00 in
Module Length:	80.00in
Number of Rows:	3
Number of Columns:	2
Total Number of Modules:	6
Desired Tilt Angle:	60
Front Edge Clearance:	5
Total Array Height at Tilt:	13.71 ft
Total Frame Length:	11.50 ft
Frame Weight:	327 lbs
Array Dimensions N/S:	10.13 ft
Array Dimensions E/W:	13.50 ft
Rail Length:	121.50 in
Rail Spacing:	3.33 ft
Rail Check:	Not Checked

Support Specifications

Pole Size:	6in Pipe Sch 40
Pole Length above Grade:	9.38 ft
Number of Poles:	1
Pole Spacing:	0

Foundation Specifications

Foundation Type:	Square
Foundation Dimensions:	48 x 48 in
Foundation Depth (below grade):	Pile 1: 5.25 ft
Foundation Volume:	3.111 y ³
Foundation Result:	PASSED
Mount Twist:	0.000001 kip

Site Info

Risk Category:	I
Exposure:	C
Soil Classification:	sand
Site Location:	6989 Centerville Rd, Eagle, NY 14024, USA
Wind Speed:	102 mph
Snow Load:	73 psf
Design Uplift Pressure:	0.021564 ksf
Design Downforce Pressure:	-0.021564 ksf
Design Snow Pressure:	0.008027 ksf

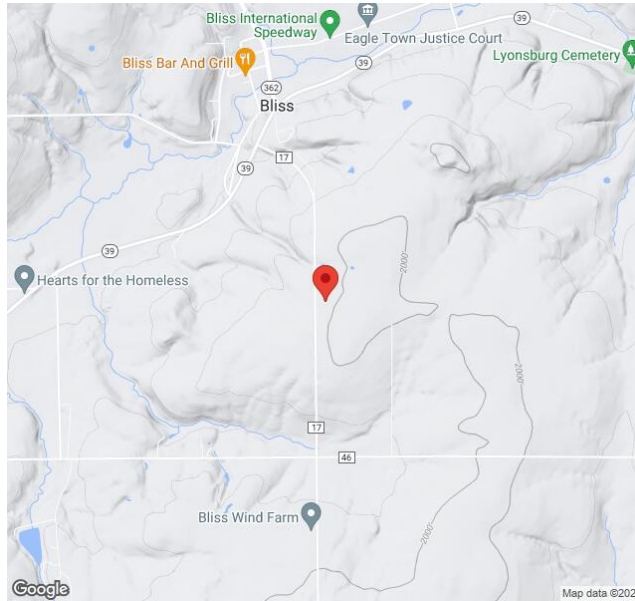

Design Disclaimer

This software should be used for preliminary designs and should not be used as a final design unless reviewed, verified and designed by a qualified structural engineer.

AutoDesigner Input

```
{
  "wind_speed_override": 102,
  "snow_load_override": 73,
  "direct_snow_load": false,
  "product_type": "Cyber",
  "project_id": "DaveM-JB-RevB",
  "site_address": "6989 Centerville Rd, Eagle, NY 14024, USA",
  "module_width": 40,
  "module_length": 80,
  "number_rows": 3,
  "number_columns": 2,
  "pole_mount_section": "6_40",
  "core_pipe_width": 36,
  "core_pipe_section": "2.5_40",
  "adjuster_section": "2_40",
  "core_beam_height": 60,
  "core_beam_section": "HSS3x2x1/8",
  "main_pipe_section": "2_40",
  "pole_spacing": 15,
  "tilt_angle": 60,
  "ground_clearance": 5,
  "risk_category": "I",
  "exposure_category": "C",
  "frame_duty_override": "auto",
  "pole_override": "auto",
  "soil_type": "sand",
  "customer_foundation_override": "48_Square",
  "foundation_type": "Square",
  "foundation_size": 48,
  "check_rails": false
}
```

Design Notes:

- AISC Deflection checks are set to L/1 due to structure design intent

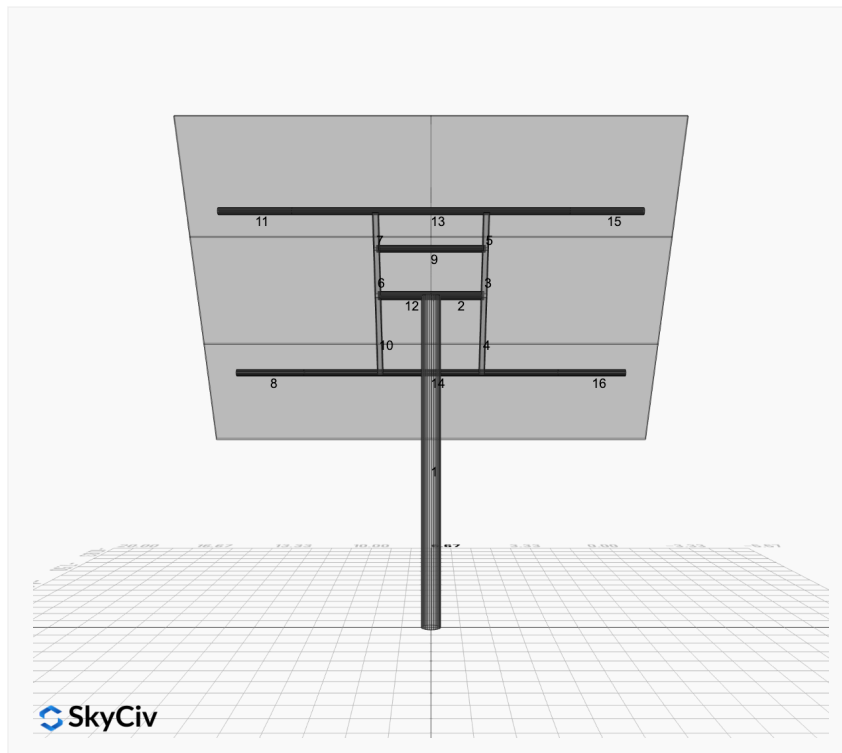

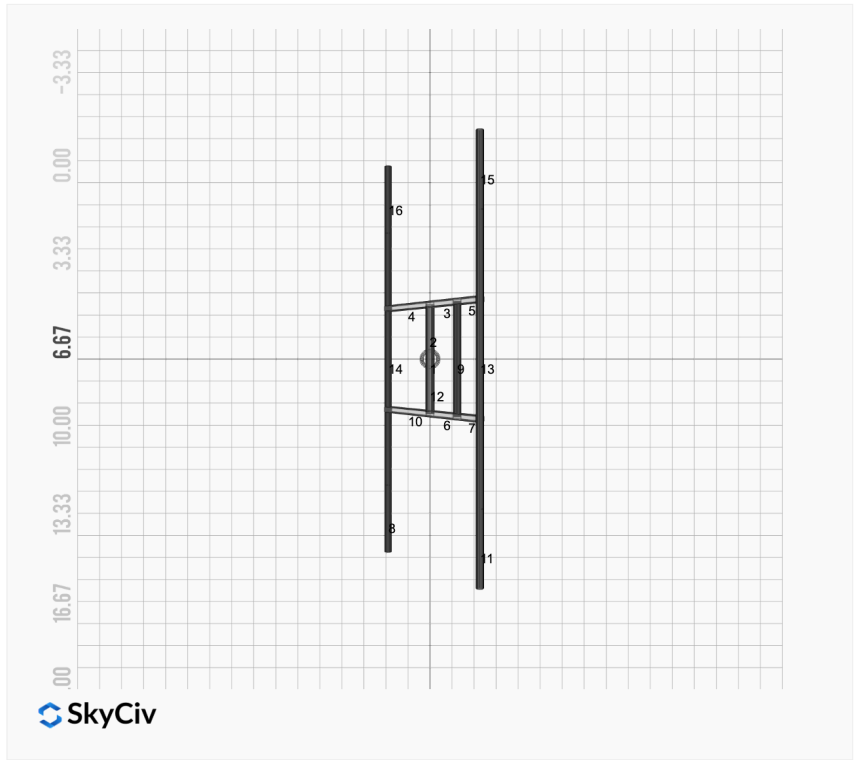
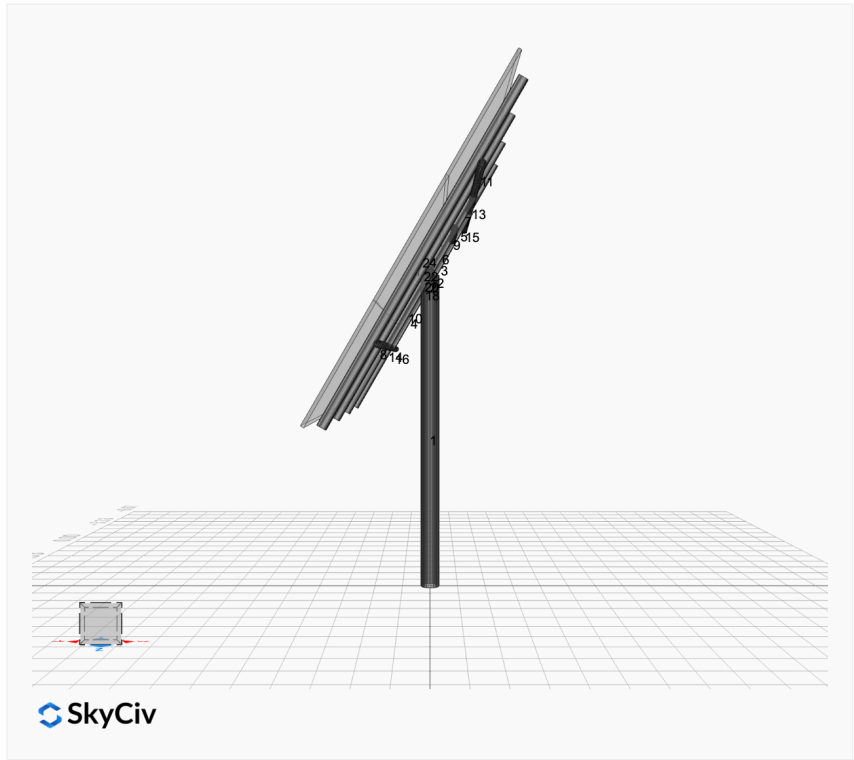

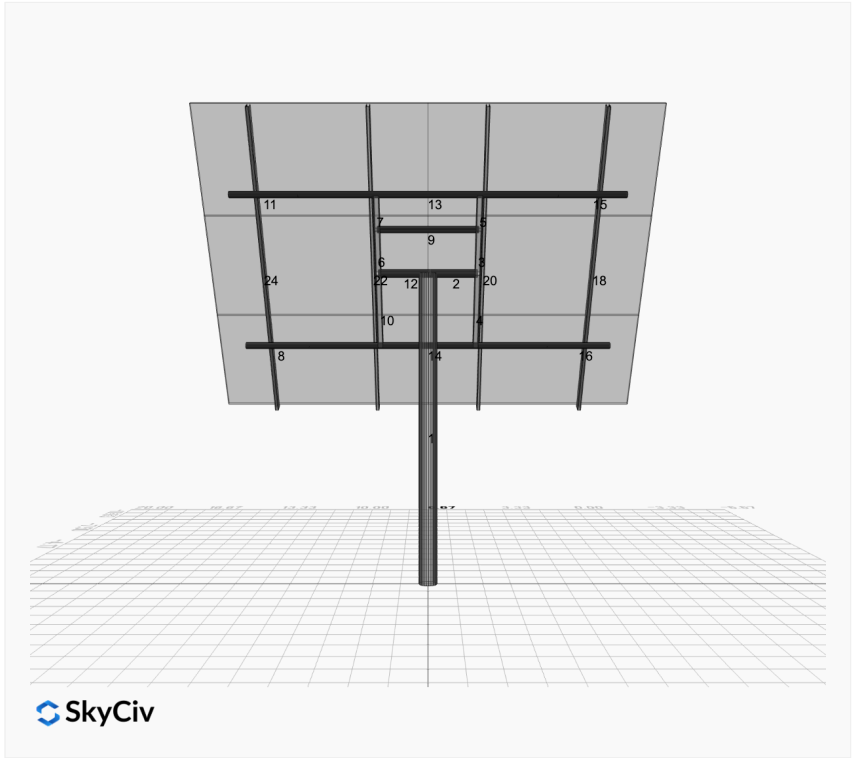
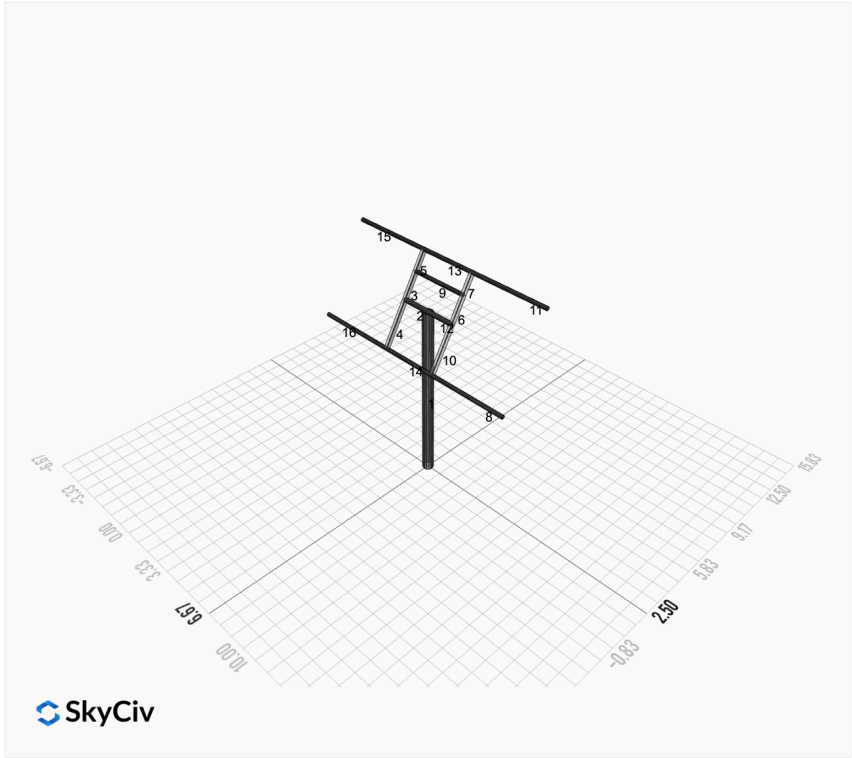

FEM Results (Envelope Worst Case for each member)

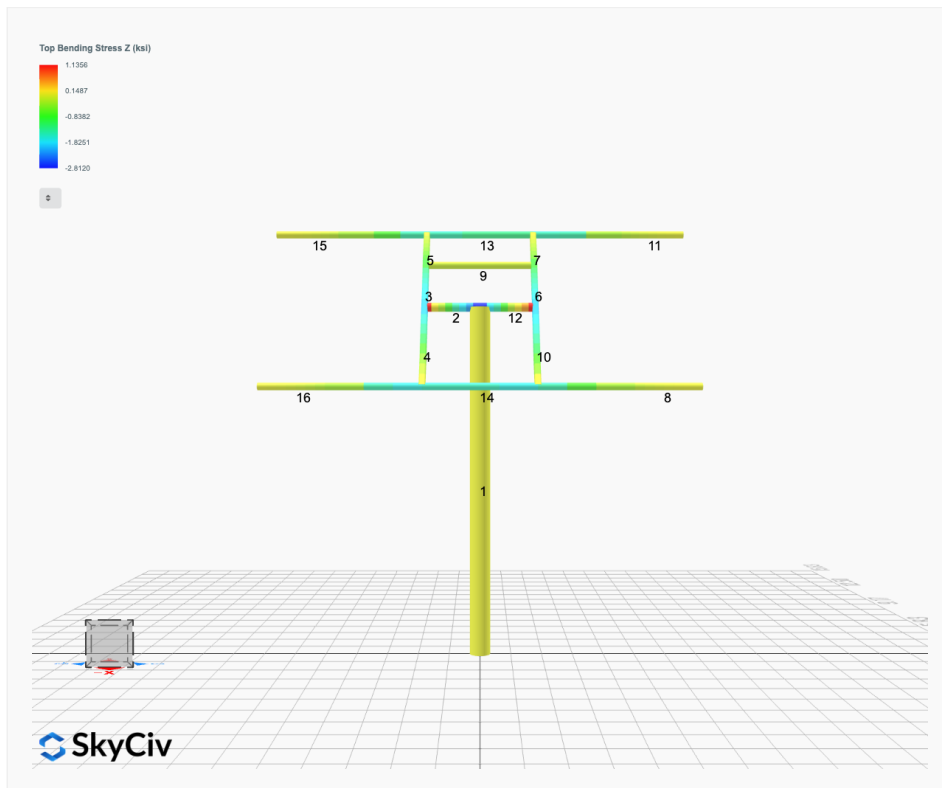
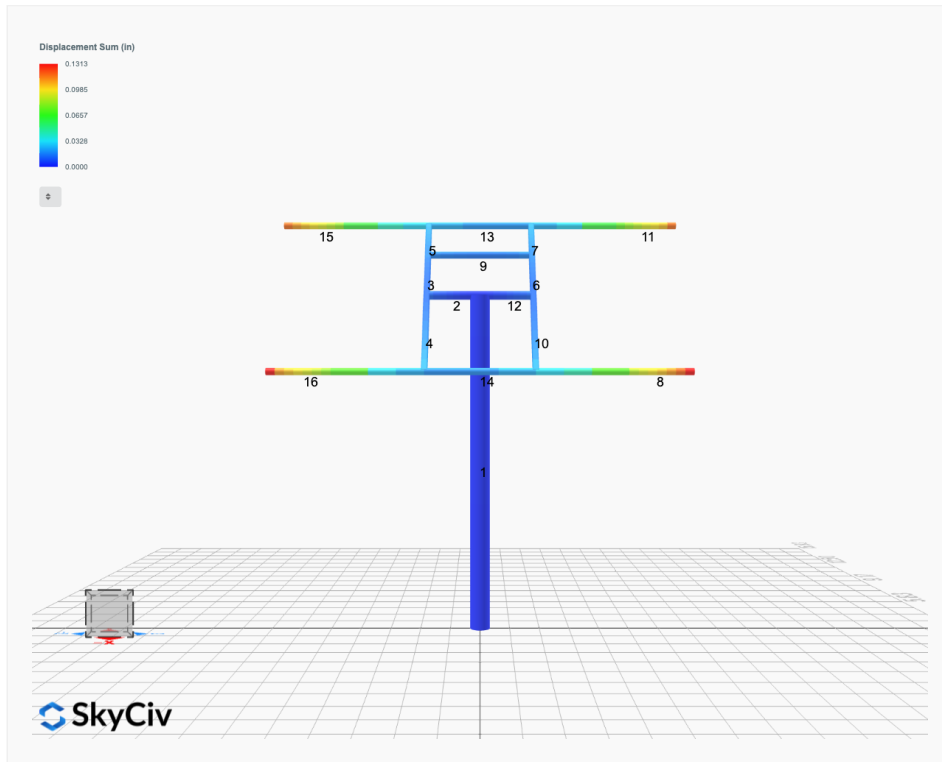

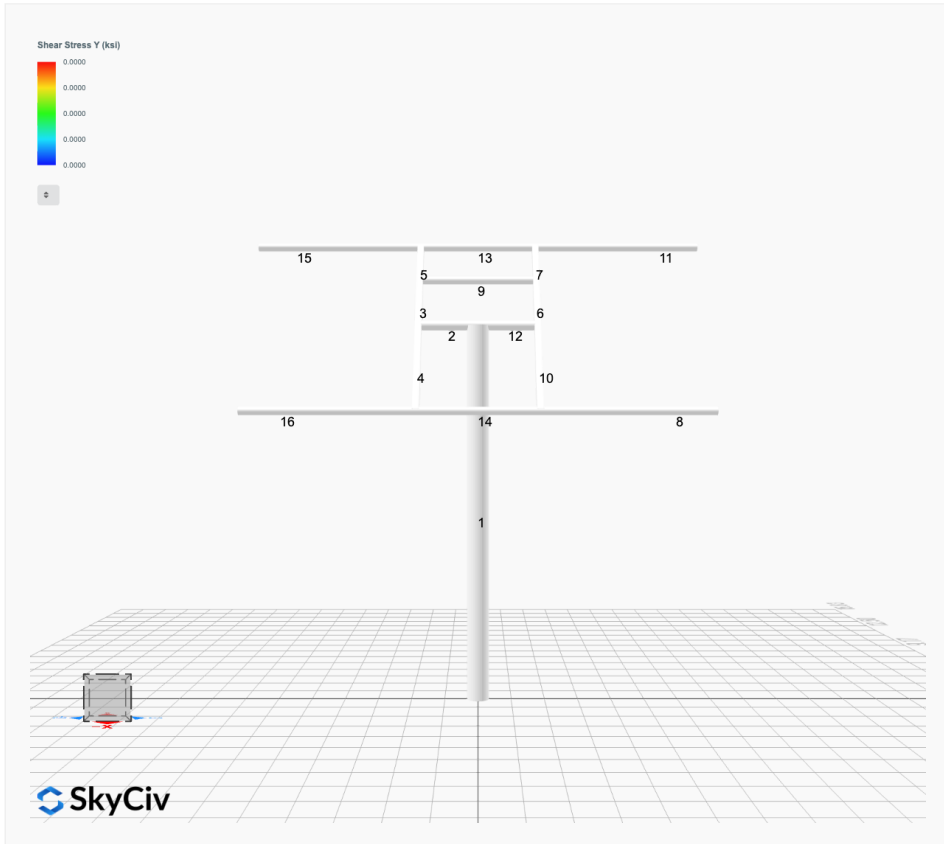
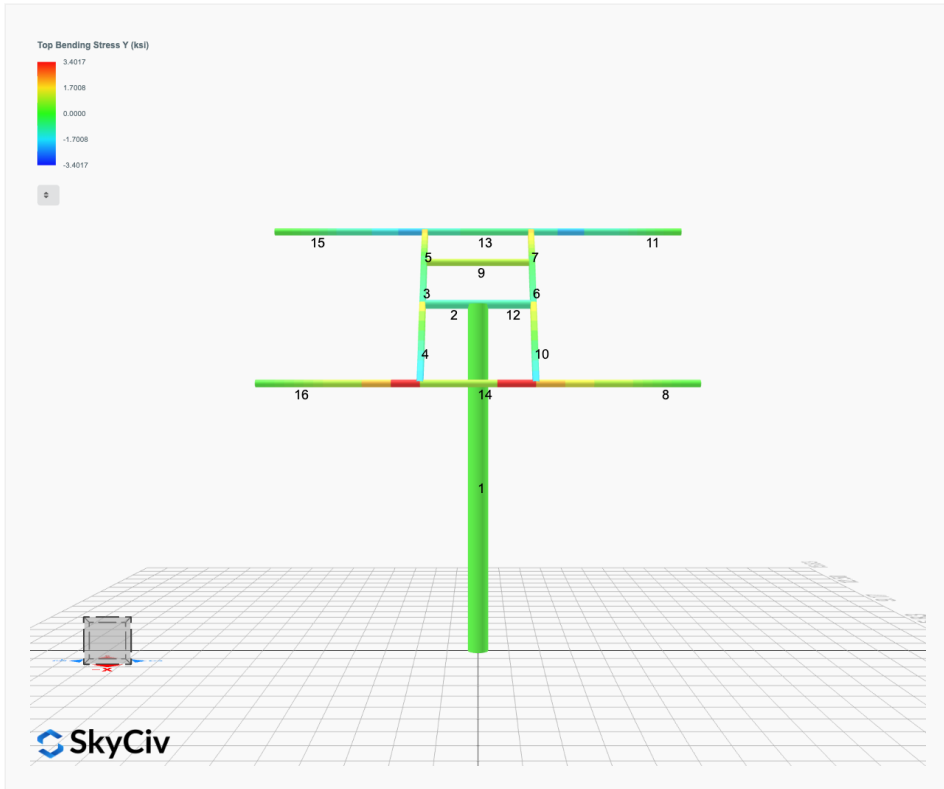

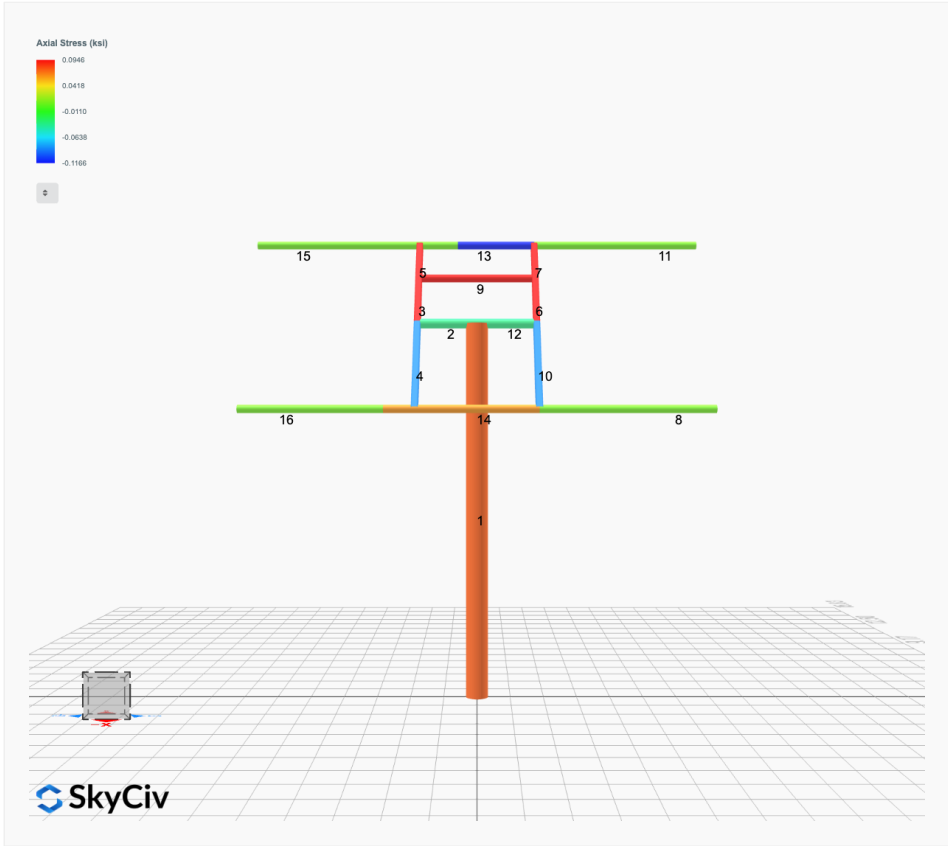

Reaction Forces for Foundation 1 (Node ID#1), (kip, kip-ft)

ASD Load Combination Results

Name	Fx	Fy	Fz	Mx	My	Mz
ULS: 1. D	-0.0000	0.9938	0.0000	0.0000	-0.0000	0.0088
ULS: 2. D + L	-0.0000	0.9938	0.0000	0.0000	-0.0000	0.0088
ULS: 3. D + (S or Lr or R)	-0.0000	1.4612	-0.0000	0.0000	-0.0000	0.0092
ULS: 3. D + (S or Lr or R)	-0.0000	0.9938	0.0000	0.0000	-0.0000	0.0088
ULS: 4. D + 0.75L + 0.75(S or Lr or R)	-0.0000	1.3444	-0.0000	0.0000	-0.0000	0.0091
ULS: 4. D + 0.75L + 0.75(S or Lr or R)	-0.0000	0.9938	0.0000	0.0000	-0.0000	0.0088
ULS: 5b. D + 0.7E	-0.0000	0.9938	0.0000	0.0000	-0.0000	0.0088
ULS: 6b. D + 0.75L + 0.75(0.7)E + 0.75S	-0.0000	1.3444	-0.0000	0.0000	-0.0000	0.0091
ULS: 8. 0.6D + 0.7E	-0.0000	0.5963	0.0000	0.0000	-0.0000	0.0053
ULS: 5a. D + 0.6W_Wind downforce Case A only	-1.5316	1.8781	0.0000	0.0000	-0.0000	14.4925
ULS: 5a. D + 0.6W_Wind downforce Case B only	-0.0000	0.9938	0.0000	0.0000	-0.0000	0.0088
ULS: 5a. D + 0.6W_Wind uplift Case A only	1.5316	0.1096	0.0000	0.0000	-0.0000	-14.2555
ULS: 5a. D + 0.6W_Wind uplift Case B only	-0.0000	0.9938	0.0000	0.0000	-0.0000	0.0088
ULS: 6a. D + 0.75L + 0.75(0.6)W + 0.75(S or Lr or R)_Wind downforce Case A only	-1.1487	2.0076	-0.0000	0.0000	-0.0000	10.8719
ULS: 6a. D + 0.75L + 0.75(0.6)W + 0.75(S or Lr or R)_Wind downforce Case B only	-0.0000	1.3444	-0.0000	0.0000	-0.0000	0.0091
ULS: 6a. D + 0.75L + 0.75(0.6)W + 0.75(S or Lr or R)_Wind uplift Case A only	1.1487	0.6812	-0.0000	0.0000	-0.0000	-10.6891
ULS: 6a. D + 0.75L + 0.75(0.6)W + 0.75(S or Lr or R)_Wind uplift Case B only	-0.0000	1.3444	-0.0000	0.0000	-0.0000	0.0091
ULS: 6a. D + 0.75L + 0.75(0.6)W + 0.75(S or Lr or R)_Wind downforce Case A only	-1.1487	1.6571	0.0000	0.0000	-0.0000	10.8716
ULS: 6a. D + 0.75L + 0.75(0.6)W + 0.75(S or Lr or R)_Wind downforce Case B only	-0.0000	0.9938	0.0000	0.0000	-0.0000	0.0088
ULS: 6a. D + 0.75L + 0.75(0.6)W + 0.75(S or Lr or R)_Wind uplift Case A only	1.1487	0.3306	0.0000	0.0000	-0.0000	-10.6894
ULS: 6a. D + 0.75L + 0.75(0.6)W + 0.75(S or Lr or R)_Wind uplift Case B only	-0.0000	0.9938	0.0000	0.0000	-0.0000	0.0088
ULS: 7. 0.6D + 0.6W_Wind downforce Case A only	-1.5316	1.4806	0.0000	0.0000	-0.0000	14.4890
ULS: 7. 0.6D + 0.6W_Wind downforce Case B only	-0.0000	0.5963	0.0000	0.0000	-0.0000	0.0053
ULS: 7. 0.6D + 0.6W_Wind uplift Case A only	1.5316	-0.2880	0.0000	0.0000	-0.0000	-14.2590
ULS: 7. 0.6D + 0.6W_Wind uplift Case B only	-0.0000	0.5963	0.0000	0.0000	-0.0000	0.0053

Worst Case Reactions LRFD

These calculations are taken directly from the FEA via SkyCiv and are used in the Concrete Checks of the Foundation Module.
Note: Worst case values are assumed as downforce wind load cases.

Result	Value (kip, kip-ft)
Axial	2.9001
Shear X	-2.5527
Shear Z	-0.0000
Moment X	0.0000
Moment Y (Twist)	0.0000
Moment Z	24.3494

Worst Case Reactions ASD

These results are taken from the worst case values in the above table and are used in the Soil Checks in the Foundation Module.
Note: Worst case values are assumed as downforce wind load cases.

Result	Value (kip, kip-ft)
Axial	2.0076
Shear X	-1.5316
Shear Z	0.0000
Moment X	0.0000
Moment Y (Twist)	0.0000
Moment Z	14.4925

Project Details

Design Code: AISC 360-16 LRFD
 Provision: LRFD
 Country: United States

User Name: sales@mtsolar.us
 Unit System: imperial



Design Input Information

Design Factors			
Φ_t	Φ_c	Φ_b	Φ_v
0.9	0.9	0.9	0.9

Design Materials			
ID	E (ksi)	F_y (ksi)	F_u (ksi)
1	29000	50	65

Section Dimensions							

ID	Name	d (in)	t_w (in)				
1	2in Pipe Sch 40	2.38	0.15				
7	6in Pipe Sch 40	6.63	0.28				
27	2.5in Pipe Sch 40	2.88	0.20				

Section Dimensions							

ID	Name	d (in)	b (in)	t_w (in)	t_b (in)	r (in)	
29	HSS3x2x1/8	3.00	2.00	0.12	0.12	0.12	

Section Properties								
ID	Name	A (in ²)	J (in ⁴)	I_{yp} (in ⁴)	I_{zp} (in ⁴)	I_w (in ⁶)	S_{yp} (in ³)	S_{zp} (in ³)
1	2in Pipe Sch 40	1.07	1.33	0.67	0.67	0.00	0.76	0.76
7	6in Pipe Sch 40	5.58	56.28	28.14	28.14	0.00	11.28	11.28
27	2.5in Pipe Sch 40	1.70	3.06	1.53	1.53	0.00	1.45	1.45
29	HSS3x2x1/8	1.07	1.47	0.69	1.30	3.45	0.80	1.06

Member Properties									
Member ID	Section ID	$K_z L$ (ft)	$K_y L$ (ft)	L_b (ft)	C_b	LST	LSC	LD	
1	7	19.71	19.71	9.38	-	300	200	1	
2	27	0.98	0.98	1.50	-	300	200	1	

										0	0	
3	29	0.92	0.92	1.4 2	1.30,1.30,1.30,1.30,1.30,1.30,1.29,1.30,1.29,1.30,1.29,1.30,1.29,1.30,1.29,1.30,1.29,1.30,1.28,1.30,1.30, 1.30,1.29,1.30,1.29,1.30,1.29,1.30	3 0 0	2 0 0				1	
4	29	1.63	1.63	2.5 0	1.68,1.68,1.68,1.67,1.68,1.68,1.67,1.68,1.67,1.68,1.67,1.68,1.67,1.68,1.67,1.68,1.67,1.66,1.67,1.67, 1.68,1.66,1.68,1.67,1.68,1.67,1.68	3 0 0	2 0 0				1	
5	29	0.70	0.70	1.0 8	1.67,1.67,1.67,1.67,1.67,1.67,1.67,1.67,1.67,1.67,1.67,1.67,1.67,1.67,1.67,1.67,1.67,1.67,1.66,1.67,1.67, 1.67,1.66,1.67,1.67,1.67,1.67,1.67	3 0 0	2 0 0				1	
6	29	0.92	0.92	1.4 2	1.30,1.30,1.30,1.30,1.30,1.30,1.29,1.30,1.29,1.30,1.29,1.30,1.29,1.30,1.29,1.30,1.29,1.30,1.29,1.30,1.30, 1.30,1.29,1.30,1.29,1.30,1.29,1.30	3 0 0	2 0 0				1	
7	29	0.70	0.70	1.0 8	1.67,1.67,1.67,1.67,1.67,1.67,1.67,1.67,1.67,1.67,1.67,1.67,1.67,1.67,1.67,1.67,1.67,1.67,1.66,1.67,1.67, 1.67,1.66,1.67,1.67,1.67,1.67,1.67	3 0 0	2 0 0				1	
8	1	4.20	4.20	2.0 0	-	3 0 0	2 0 0				1	
9	1	1.95	1.95	3.0 0	-	3 0 0	2 0 0				1	
10	29	1.63	1.63	2.5 0	1.68,1.68,1.68,1.67,1.68,1.68,1.67,1.68,1.67,1.68,1.67,1.68,1.67,1.68,1.67,1.68,1.67,1.67,1.66,1.67,1.67, 1.68,1.66,1.68,1.67,1.68,1.67,1.68	3 0 0	2 0 0				1	
11	1	4.20	4.20	2.0 0	-	3 0 0	2 0 0				1	
12	27	0.98	0.98	1.5 0	-	3 0 0	2 0 0				1	
13	1	4.88	3.00	7.5 0	-	3 0 0	2 0 0				1	
14	1	4.88	3.00	7.5 0	-	3 0 0	2 0 0				1	
15	1	4.20	4.20	2.0 0	-	3 0 0	2 0 0				1	
16	1	4.20	4.20	2.0 0	-	3 0 0	2 0 0				1	

Member Design Capacity

Member ID	$\Phi_t P_n$ (kip)	$\Phi_c P_n$ (kip)	$\Phi_b M_{zn}$ (k-ft)	$\Phi_b M_{yn}$ (k-ft)	$\Phi_v V_{yn}$ (kip)	$\Phi_v V_{zn}$ (kip)
1	251.16	111.62	42.30	42.30	75.35	75.35
2	76.68	75.83	5.45	5.45	23.00	23.00
3	48.15	47.49	3.97	3.01	16.61	10.35
4	48.15	46.12	3.97	3.01	16.61	10.35
5	48.15	47.76	3.97	3.01	16.61	10.35
6	48.15	47.49	3.97	3.01	16.61	10.35
7	48.15	47.76	3.97	3.01	16.61	10.35
8	48.35	35.83	2.85	2.85	14.51	14.51
9	48.35	45.33	2.85	2.85	14.51	14.51
10	48.15	46.12	3.97	3.01	16.61	10.35
11	48.35	35.83	2.85	2.85	14.51	14.51
12	76.68	75.83	5.45	5.45	23.00	23.00
13	48.35	32.29	2.85	2.85	14.51	14.51
14	48.35	32.29	2.85	2.85	14.51	14.51
15	48.35	35.83	2.85	2.85	14.51	14.51
16	48.35	35.83	2.85	2.85	14.51	14.51

Design Ratio

Member ID	P	M _z	M _y	V _y	V _z	(P,M _z ,M _y)	Worst LC	KL/r	δ	Status
1	0.026	0.576	0.000	0.034	0.000	0.589	#13	0.527	Not Required	Pass
2	0.002	0.330	0.398	0.058	0.055	0.728	#13	0.041	Not Required	Pass
3	0.008	0.560	0.052	0.053	0.009	0.599	#13	0.069	Not Required	Pass
4	0.008	0.556	0.128	0.053	0.026	0.625	#13	0.081	Not Required	Pass
5	0.008	0.242	0.139	0.053	0.042	0.257	#13	0.053	Not Required	Pass
6	0.008	0.560	0.052	0.053	0.009	0.600	#13	0.069	Not Required	Pass
7	0.008	0.242	0.139	0.053	0.042	0.257	#13	0.053	Not Required	Pass
8	0.000	0.107	0.044	0.021	0.009	0.137	#13	Not Required	Not Required	Pass
9	0.008	0.084	0.160	0.001	0.000	0.247	#13	0.149	Not Required	Pass
10	0.008	0.556	0.128	0.053	0.026	0.625	#13	0.081	Not Required	Pass
11	0.000	0.107	0.044	0.021	0.009	0.137	#13	Not Required	Not Required	Pass
12	0.002	0.330	0.398	0.058	0.055	0.728	#13	0.041	Not Required	Pass
13	0.009	0.484	0.197	0.045	0.018	0.619	#13	0.248	Not Required	Pass
14	0.008	0.484	0.197	0.045	0.018	0.619	#13	0.248	Not Required	Pass
15	0.000	0.107	0.044	0.021	0.009	0.137	#13	Not Required	Not Required	Pass
16	0.000	0.107	0.044	0.021	0.009	0.137	#13	Not Required	Not Required	Pass

Definitions

Φ_t	Safety factor for tensile
Φ_c	Safety factor for compression
Φ_b	Safety factor for flexure
Φ_v	Safety factor for shear
E	Modulus of elasticity
F _y	Specified minimum yield stress
F _u	Specified minimum tensile strength
A	Cross-sectional area
J	Torsional constant
I _{yp}	Moment of inertia about the Y axes
I _{zp}	Moment of inertia about the Z axes
I _w	Warping constant
S _{yp}	Plastic section modulus about the Y axis
S _{zp}	Plastic section modulus about the Z axis
KL	Effective length
C _b	Buckling modification factor (from all load combinations)
L _b	Length between braced points
LST	Limited slenderness for tension
LSC	Limited slenderness for compression
LD	Limited deflection
P _n	Nominal axial strength (tension/compression)
M _n	Nominal flexural strength (about Z/Y axis)
V _n	Nominal shear strength (along Z/Y axis)
P	Design ratio in case of axial force
M _z	Design ratio in case of bending about Z axis
M _y	Design ratio in case of bending about Y axis
V _y	Design ratio in case of shear along Y axis
V _z	Design ratio in case of shear along Z axis
(P,M _z ,M _y)	Design ratio in case of axial force and bending action
KL/r	Design ratio in case of section slenderness
δ	Design ratio in case of member deflection
OK	Capacity is provided
NG	Capacity is not provided

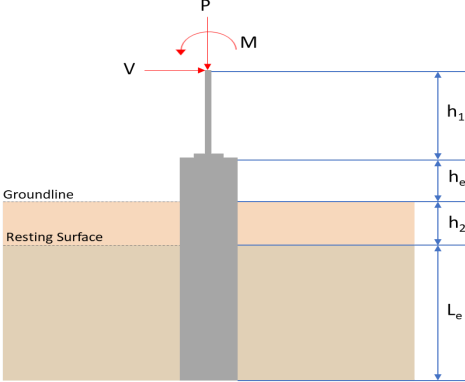
REFERENCES	CALCULATIONS	RESULTS																										
	<p>SkyCiv Foundation Design Pile Foundation</p> <p>Design Information : Design code : IBC 2021 (International Building Code) Unit System : Imperial</p>																											
	<p>Pile Input</p>  <p>Geometry Pile shape: rectangular $b = 48$ in - Pile width $D = 48$ in - Pile depth $L = 5.25$ ft - Total pile length $h_1 = 0$ ft - Lateral load height from the top of the pile, $h_2 = 0$ ft - Depth to resting surface $h_e = 0$ ft - Length of pile above the ground</p> <p>Tabulation of Soil Parameters</p> <table border="1" data-bbox="416 1102 1193 1191"> <thead> <tr> <th>Layer</th> <th>Label</th> <th>Allowable Bearing Pressure (q_a) (psf)</th> <th>Allowable Lateral Pressure (R) (psf/ft)</th> </tr> </thead> <tbody> <tr> <td>1</td> <td>Sand, silty sand, clayey sand, silty gravel & clayey gravel</td> <td>2000.000</td> <td>150.000</td> </tr> </tbody> </table> <p>Tabulation of Loads</p> <table border="1" data-bbox="676 1288 935 1458"> <thead> <tr> <th>Load Component</th> <th>ASD</th> <th>LRFD</th> </tr> </thead> <tbody> <tr> <td>P (kip)</td> <td>2.008</td> <td>2.900</td> </tr> <tr> <td>V_x (kip)</td> <td>-1.532</td> <td>-2.553</td> </tr> <tr> <td>V_z (kip)</td> <td>0.000</td> <td>0.000</td> </tr> <tr> <td>M_x (kipft)</td> <td>0.000</td> <td>0.000</td> </tr> <tr> <td>M_z (kipft)</td> <td>14.492</td> <td>24.349</td> </tr> </tbody> </table> <p>Material Properties $f'_{ck} = 2.5$ ksi - Concrete strength,</p>	Layer	Label	Allowable Bearing Pressure (q_a) (psf)	Allowable Lateral Pressure (R) (psf/ft)	1	Sand, silty sand, clayey sand, silty gravel & clayey gravel	2000.000	150.000	Load Component	ASD	LRFD	P (kip)	2.008	2.900	V_x (kip)	-1.532	-2.553	V_z (kip)	0.000	0.000	M_x (kipft)	0.000	0.000	M_z (kipft)	14.492	24.349	
Layer	Label	Allowable Bearing Pressure (q_a) (psf)	Allowable Lateral Pressure (R) (psf/ft)																									
1	Sand, silty sand, clayey sand, silty gravel & clayey gravel	2000.000	150.000																									
Load Component	ASD	LRFD																										
P (kip)	2.008	2.900																										
V_x (kip)	-1.532	-2.553																										
V_z (kip)	0.000	0.000																										
M_x (kipft)	0.000	0.000																										
M_z (kipft)	14.492	24.349																										
	<p>Required depth to resist lateral loads (ASD) H - Point of application of the lateral load</p> $H = h_1 + h_2 + h_e$ $H = (0 \text{ ft}) + (0 \text{ ft}) + (0 \text{ ft})$ $H = 0 \text{ ft}$ <p>Considering x-direction: H_o - Lateral force per length of pile,</p> $H_o = \frac{V_x}{1.57 D}$ $H_o = \frac{(-1.532 \text{ kip})}{1.57 \times (48 \text{ in})}$ $H_o = -0.24395 \text{ kip/ft}$ <p>M_o - Moment per length of pile,</p> $M_o = \frac{M_z + (V_x H)}{1.57 D}$																											

$$M_o = \frac{(14.492 \text{ kipft}) + ((-1.532 \text{ kip}) \times (0 \text{ ft}))}{1.57 \times (48 \text{ in})}$$

$$M_o = 2.3076 \text{ kipft/ft}$$

Required depth of embedment in earth:

$$L_x^3 - \left(14.14 \times \frac{H_o \times L_x}{R}\right) - \left(18.85 \times \frac{M_o}{R}\right) = 0$$

Solving the cubic equation:

$$L_{e,x} = 4.8446 \text{ ft} - \text{Required depth in x-direction,}$$

Considering z-direction:

$$L_{e,z} = 0 \text{ ft} - \text{Required depth in z-direction,}$$

Minimum embedded depth required:

$L_{e,req}$ - Depth of pile required,

$$L_{e,req} = \text{MAX}[L_{e,x}, L_{e,z}]$$

$$L_{e,req} = \text{MAX}[(4.8446 \text{ ft}), (0 \text{ ft})]$$

$$L_{e,req} = 4.845 \text{ ft}$$

L_e - Actual embedded length of pile,

$$L_e = L - h_e - h_2$$

$$L_e = (5.25 \text{ ft}) - (0 \text{ ft}) - (0 \text{ ft})$$

$$L_e = 5.25 \text{ ft}$$

Ratio - Embedded depth

$$\text{Ratio} = \frac{L_{e,req}}{L_e}$$

$$\text{Ratio} = \frac{(4.845 \text{ ft})}{(5.25 \text{ ft})}$$

$$\text{Ratio} = 0.92286$$

Status: **PASS**
Ratio: **0.920**

End-bearing Capacity (ASD)

A - Pile cross-section area

$$A = b D$$

$$A = (48 \text{ in}) \times (48 \text{ in})$$

$$A = 16 \text{ ft}^2$$

q - End-bearing pressure

$$q = \frac{P_v}{A}$$

$$q = \frac{(2.008 \text{ kip})}{(16 \text{ ft}^2)}$$

$$q = 0.1255 \text{ kip/ft}^2$$

Check bearing capacity ratio:

Ratio - Capacity

$$\text{Ratio} = \frac{q}{q_o}$$

$$\text{Ratio} = \frac{(0.1255 \text{ kip/ft}^2)}{(2000 \text{ psf})}$$

$$\text{Ratio} = 0.06275$$

Status: **PASS**
Ratio: **0.060**

Czerniak

Lateral Soil Pressure (ASD):

L/D - Length to least lateral dimension ratio,

$$L/D = \frac{L}{D}$$

$$L/D = \frac{(5.25 \text{ ft})}{(48 \text{ in})}$$

$$L/D = 1.3125$$

Since $L/D \leq 10$,

Pile is short.

Considering x-direction:

$H_o = -0.24395$ kip/ft - Lateral force per length of pile,

$M_o = 2.3076$ kipft/ft - Overturning moment per length of pile,

a - Distance from resting surface to pivot point,

$$a = \frac{(4 M_o L_e) + (3 H_o L_e^2)}{(6 M_o) + (4 H_o L_e)}$$

$$a = \frac{(4 \times (2.3076 \text{ kipft/ft}) \times (5.25 \text{ ft})) + (3 \times (-0.24395 \text{ kip/ft}) \times (5.25 \text{ ft})^2)}{(6 \times (2.3076 \text{ kipft/ft})) + (4 \times (-0.24395 \text{ kip/ft}) \times (5.25 \text{ ft}))}$$

$$a = 3.6182 \text{ ft}$$

p - Earth pressure against the pile at distance $a/2$ from resting surface,

$$p = \frac{0.75 [(4 M_o) + (3 H_o L_e)]^2}{L_e^2 [(3 M_o) + (2 H_o L_e)]}$$

$$p = \frac{0.75 \times [(4 \times (2.3076 \text{ kipft/ft})) + (3 \times (-0.24395 \text{ kip/ft}) \times (5.25 \text{ ft}))]^2}{(5.25 \text{ ft})^2 \times [(3 \times (2.3076 \text{ kipft/ft})) + (2 \times (-0.24395 \text{ kip/ft}) \times (5.25 \text{ ft}))]}$$

$$p = 0.18114 \text{ kip/ft}^2$$

s - Earth pressure against the pile at distance L_e ,

$$s = \frac{6 [(2 M_o) + (H_o L_e)]}{L_e^2}$$

$$s = \frac{6 \times [(2 \times (2.3076 \text{ kipft/ft})) + ((-0.24395 \text{ kip/ft}) \times (5.25 \text{ ft}))]}{(5.25 \text{ ft})^2}$$

$$s = 0.72589 \text{ kip/ft}^2$$

Check lateral soil pressure capacity:

p_a - Allowable lateral soil pressure at depth $a/2$,

$$p_a = R \frac{a}{2}$$

$$p_a = (150 \text{ psf/ft}) \times \frac{(3.6182 \text{ ft})}{2}$$

$$p_a = 0.27136 \text{ kip/ft}^2$$

Ratio - Lateral soil capacity

$$\text{Ratio} = \frac{p}{p_a}$$

$$\text{Ratio} = \frac{(0.18114 \text{ kip/ft}^2)}{(0.27136 \text{ kip/ft}^2)}$$

$$\text{Ratio} = 0.66754$$

p_s - Allowable lateral soil pressure at depth L_e ,

$$p_s = R L_e$$

$$p_s = (150 \text{ psf/ft}) \times (5.25 \text{ ft})$$

$$p_s = 0.7875 \text{ kip/ft}^2$$

Ratio - Lateral soil capacity

$$\text{Ratio} = \frac{s}{p_s}$$

$$\text{Ratio} = \frac{(0.72589 \text{ kip/ft}^2)}{(0.7875 \text{ kip/ft}^2)}$$

$$\text{Ratio} = 0.92176$$

Status: **PASS**
Ratio: **0.670**

Status: **PASS**
Ratio: **0.920**

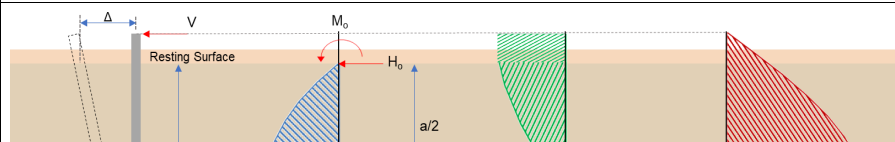

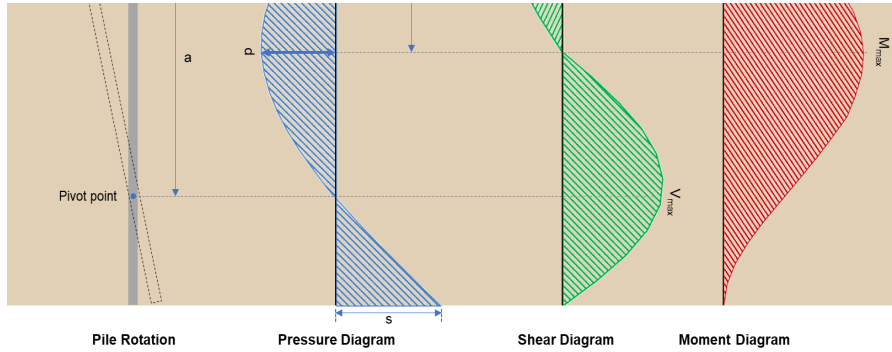

Shear force and Bending moment (x-direction, LRFD)

H_o - Lateral force per length of pile,

$$H_o = \frac{V_x}{1.57 D}$$

$$H_o = \frac{(-2.553 \text{ kip})}{1.57 \times (48 \text{ in})}$$

$$H_o = -0.40653 \text{ kip/ft}$$

M_o - Moment per length of pile,

$$M_o = \frac{M_x + (V_x H)}{1.57 D}$$

$$M_o = \frac{(24.349 \text{ kipft}) + ((-2.553 \text{ kip}) \times (0 \text{ ft}))}{1.57 \times (48 \text{ in})}$$

$$M_o = 3.8772 \text{ kipft/ft}$$

E - Distance from lateral load to resisting surface,

$$E = \frac{M_o}{H_o}$$

$$E = \frac{(3.8772 \text{ kipft/ft})}{(-0.40653 \text{ kip/ft})}$$

$$E = 9.5374 \text{ ft}$$

a - Distance from resting surface to pivot point,

$$a = \frac{(4 M_o L_c) + (3 H_o L_c^2)}{(6 M_o) + (4 H_o L_c)}$$

$$a = \frac{(4 \times (3.8772 \text{ kipft/ft}) \times (5.25 \text{ ft})) + (3 \times (-0.40653 \text{ kip/ft}) \times (5.25 \text{ ft})^2)}{(6 \times (3.8772 \text{ kipft/ft})) + (4 \times (-0.40653 \text{ kip/ft}) \times (5.25 \text{ ft}))}$$

$$a = 3.6175 \text{ ft}$$

V_{max} - Max shear force located at depth a ,

$$V_{max} = (H_o D) \left[1 - \left[3 \left(\frac{4 E}{L_c} + 3 \right) \left(\frac{a}{L_c} \right)^2 \right] + \left[4 \left(\frac{3 E}{L_c} + 2 \right) \left(\frac{a}{L_c} \right)^3 \right] \right]$$

$$V_{max} = ((-0.40653 \text{ kip/ft}) \times (48 \text{ in})) \times \left[1 - \left[3 \times \left(\frac{4 \times (9.5374 \text{ ft})}{(5.25 \text{ ft})} + 3 \right) \times \left(\frac{(3.6175 \text{ ft})}{(5.25 \text{ ft})} \right)^2 \right] + \left[4 \times \left(\frac{3 \times (9.5374 \text{ ft})}{(5.25 \text{ ft})} + 2 \right) \times \left(\frac{(3.6175 \text{ ft})}{(5.25 \text{ ft})} \right)^3 \right] \right]$$

$$V_{max} = 6.3001 \text{ kip}$$

M_{max} - Max bending moment located at depth $a/2$,

$$M_{max} = (H_o D L_c) \left[\left(\frac{E}{L_c} + \frac{a}{2 L_c} \right) - \left[\left(\frac{4 E}{L_c} + 3 \right) \left(\frac{a}{2 L_c} \right)^3 \right] + \left[\left(\frac{3 E}{L_c} + 2 \right) \left(\frac{a}{2 L_c} \right)^4 \right] \right]$$

$$M_{max} = ((-0.40653 \text{ kip/ft}) \times (48 \text{ in}) \times (5.25 \text{ ft})) \times \left[\left(\frac{(9.5374 \text{ ft})}{(5.25 \text{ ft})} + \frac{(3.6175 \text{ ft})}{2 \times (5.25 \text{ ft})} \right) - \left[\left(\frac{4 \times (9.5374 \text{ ft})}{(5.25 \text{ ft})} + 3 \right) \times \left(\frac{(3.6175 \text{ ft})}{2 \times (5.25 \text{ ft})} \right)^3 \right] + \left[\left(\frac{3 \times (9.5374 \text{ ft})}{(5.25 \text{ ft})} + 2 \right) \times \left(\frac{(3.6175 \text{ ft})}{2 \times (5.25 \text{ ft})} \right)^4 \right] \right]$$

$$M_{max} = 15.762 \text{ kipft}$$

Minimum Reinforcement Check (LRFD)

Parameters:

$f'_{ck} = 2.5 \text{ ksi}$ - Concrete strength,
 $f_{yk} = 60 \text{ ksi}$ - Longitudinal reinforcement strength,
 $\phi = 0.65$ - Reduction factor for axial strength,
 $\alpha = 0.8$ - Alpha factor for axial strength,
 $A_g = 2304 \text{ in}^2$ - Gross area of concrete,

Table 22.4.2.1

Longitudinal reinforcement:

Required reinforcement due to axial load, $A_{st,required}$

22.4.2.2, 10.6.1.1

$A_{st,required}$

$$A_{st,required} = \text{Min} \left[\frac{\frac{P}{\phi \alpha} - (0.85 f'_{ck} A_g)}{f_{yk} - (0.85 f'_{ck})}, (0.08 A_g) \right]$$

$$A_{st,required} = \text{Min} \left[\frac{\frac{(2.9 \text{ kip})}{(0.65) \times (0.8)} - (0.85 \times (2.5 \text{ ksi}) \times (2304 \text{ in}^2))}{(60 \text{ ksi}) - (0.85 \times (2.5 \text{ ksi}))}, (0.08 \times (2304 \text{ in}^2)) \right]$$

$$A_{st,required} = -84.5 \text{ in}^2$$

A_{min} - Governing minimum reinforcement area,

$$A_{min} = \text{Max} [A_{st,required}, (0.0018 A_g)]$$

$$A_{min} = \text{Max} [(-84.5 \text{ in}^2), (0.0018 \times (2304 \text{ in}^2))]$$

$$A_{min} = 4.1472 \text{ in}^2$$

n_{rebar} - Required number of reinforcement,

$$n_{rebar} = \frac{A_{min}}{A_{rebar}}$$

$$n_{rebar} = \frac{(4.1472 \text{ in}^2)}{(0.3068 \text{ in}^2)}$$

$$n_{rebar} = 14$$

A_{st} - Actual total reinforcement area,

$$A_{st} = n_{rebar} \frac{\pi d_{bar}^2}{4}$$

$$A_{st} = (14) \times \frac{\pi \times (0.625 \text{ in})^2}{4}$$

$$A_{st} = 4.2951 \text{ in}^2$$

Ratio - Capacity

$$\text{Ratio} = \frac{A_{min}}{A_{st}}$$

$$\text{Ratio} = \frac{(4.1472 \text{ in}^2)}{(4.2951 \text{ in}^2)}$$

$$\text{Ratio} = 0.96556$$

Status: **PASS**
Ratio: **0.970**

25.2.3 s_{rebar} - Minimum spacing of reinforcement,

$$s_{rebar} = \text{Max} [1.5, (1.5 d_{bar})]$$

$$s_{rebar} = \text{Max} [1.5, (1.5 \times (0.625 \text{ in}))]$$

$$s_{rebar} = 1.5 \text{ in}$$

Ties:

25.7.2.2 Since longitudinal reinforcement is \leq No. 10: Use #3(0.375 in)

25.7.2.1 s_{ties} - Maximum spacing of ties,

$$s_{ties} = \text{Min} [(16 d_{bar}), (48 d_{ties}), \text{Min} (D, b)]$$

$$s_{ties} = \text{Min} [(16 \times (0.625 \text{ in})), (48 \times (0.375 \text{ in})), \text{Min} ((48 \text{ in}), (48 \text{ in}))]$$

$$s_{ties} = 10 \text{ in}$$

Summary:

Main reinforcement: **14 - #5 (0.625 in)**

Axial Compression Strength (ACI 318-19, LRFD)22.4.2.2 ϕP_N - Allowable axial compressive strength

$$\phi P_N = \phi 0.80 [(0.85 f'_{ck} [A_g - A_{st}]) + (f_{yt} A_{st})]$$

$$\phi P_N = (0.65) \times 0.80 \times [(0.85 \times (2.5 \text{ ksi}) \times [(2304 \text{ in}^2) - (4.2951 \text{ in}^2)]) + ((60 \text{ ksi}) \times (4.2951 \text{ in}^2))]$$

$$\phi P_N = 2675.2 \text{ kip}$$

Ratio - Capacity

$$\text{Ratio} = \frac{P}{\phi P_N}$$

$$\text{Ratio} = \frac{(2.9 \text{ kip})}{(2675.2 \text{ kip})}$$

$$\text{Ratio} = 0.001084$$

Status: **PASS**
Ratio: **0.000****Shear Strength (ACI 318-19, LRFD)****Parameters:** $b_w = 48 \text{ in}$ - Effective width,22.5.2.2 d - Effective depth

$$d = 0.80 D$$

$$d = 0.80 \times (48 \text{ in})$$

$$d = 38.4 \text{ in}$$

22.5.5.1.3 λ_s - size effect modification factor

$$\lambda_s = \text{MIN} \left[\sqrt{\frac{2}{1 + \frac{d}{10}}}, 1 \right]$$

$$\lambda_s = \text{MIN} \left[\sqrt{\frac{2}{1 + \frac{(38.4 \text{ in})}{10}}}, 1 \right]$$

$$\lambda_s = 0.64282$$

The following variables were converted to be consistent with empirical formula $f'_{ck} = 2.5 \text{ ksi} \rightarrow 2500 \text{ psi}$,22.5.5.1.1 $V_{c,max}$ - Max shear strength of concrete

$$V_{c,max} = 5 \lambda_s \sqrt{f'_{ck}} b_w d$$

$$V_{c,max} = 5 \times (0.64282) \times \sqrt{(2500 \text{ psi})} \times (48 \text{ in}) \times (38.4 \text{ in})$$

$$V_{c,max} = 296.21 \text{ kip}$$

The following variables were converted to be consistent with empirical formula $f'_{ck} = 2.5 \text{ ksi} \rightarrow 2500 \text{ psi}$, $P = 2.9 \text{ kip} \rightarrow 2900 \text{ lbf}$,22.5.5.1.1(a) $V_{c,a}$ - Shear strength of concrete (a)

$$V_{c,a} = \left[2 \lambda_s \sqrt{f'_{ck}} + \frac{P}{6 A_g} \right] b_w d$$

$$V_{c,a} = \left[2 \times (0.64282) \times \sqrt{(2500 \text{ psi})} + \frac{(2900 \text{ lbf})}{6 \times (2304 \text{ in}^2)} \right] \times (48 \text{ in}) \times (38.4 \text{ in})$$

$$V_{c,a} = 118.87 \text{ kip}$$

The following variables were converted to be consistent with empirical formula $f'_{ck} = 2.5 \text{ ksi} \rightarrow 2500 \text{ psi}$,22.5.5.1.2 $V_{c,b}$ - Shear strength of concrete (b)

$$V_{c,b} = \left[2 \lambda_s \sqrt{f'_{ck}} + (0.05 f'_{ck}) \right] b_w d$$

$$V_{c,b} = \left[2 \times (0.64282) \times \sqrt{(2500 \text{ psi})} + (0.05 \times (2500 \text{ psi})) \right] \times (48 \text{ in}) \times (38.4 \text{ in})$$

$$V_{c,b} = 348.89 \text{ kip}$$

 V_c - Governing shear strength of concrete

$$V_c = \text{Min}[V_{c,max}, V_{c,a}, V_{c,b}]$$

$$V_c = \text{Min}[(296.21 \text{ kip}), (118.87 \text{ kip}), (348.89 \text{ kip})]$$

$$V_c = 118.87 \text{ kip}$$

<p>22.5.1.2</p>	<p>The following variables were converted to be consistent with empirical formula $f'_{ck} = 2.5 \text{ ksi} \rightarrow 2500 \text{ psi}$,</p> <p>$V_{s,a}$ - Shear strength of steel (a)</p> $V_{s,a} = 8 \sqrt{f'_{ck}} b_w d$ $V_{s,a} = 8 \times \sqrt{(2500 \text{ psi})} \times (48 \text{ in}) \times (38.4 \text{ in})$ $V_{s,a} = 737.28 \text{ kip}$ <p>A_v - Ties rebar area,</p> $A_v = \frac{\pi d_{ties}^2}{4}$ $A_v = \frac{\pi \times (0.375 \text{ in})^2}{4}$ $A_v = 0.11045 \text{ in}^2$ <p>22.5.8.5.3 $V_{s,b}$ - Shear strength of steel (b)</p> $V_{s,b} = \frac{2 A_v f_{ywk} d}{s_{ties}}$ $V_{s,b} = \frac{2 \times (0.11045 \text{ in}^2) \times (60 \text{ ksi}) \times (38.4 \text{ in})}{(10 \text{ in})}$ $V_{s,b} = 50.894 \text{ kip}$ <p>V_s - Governing shear strength of steel</p> $V_s = MIN[V_{s,a}, V_{s,b}]$ $V_s = MIN[(737.28 \text{ kip}), (50.894 \text{ kip})]$ $V_s = 50.894 \text{ kip}$ <p>22.5.1.1 ϕV_n - Allowable shear strength</p> $\phi V_n = \phi (V_c + V_s)$ $\phi V_n = (0.65) \times ((118.87 \text{ kip}) + (50.894 \text{ kip}))$ $\phi V_n = 110.35 \text{ kip}$ <p>Considering x-direction:</p> <p>$V_{max} = 6.3001 \text{ kip}$ - Maximum shear force in the x-direction, Ratio - Capacity</p> $Ratio = \frac{V_{max}}{\phi V_n}$ $Ratio = \frac{(6.3001 \text{ kip})}{(110.35 \text{ kip})}$ $Ratio = 0.057093$	<p>Status: PASS Ratio: 0.060</p>
<p>14.5.2.1b</p>	<p>Flexural Strength (ACI 318-19, LRFD)</p> <p>S_m - Section modulus</p> $S_m = \frac{b D^2}{6}$ $S_m = \frac{(48 \text{ in}) \times (48 \text{ in})^2}{6}$ $S_m = 18432 \text{ in}^3$ <p>$\lambda = 1$ - Concrete modification factor (Normal concrete), Allowable flexural strength: M_n shall be the lesser of:</p> <p>$\phi M_{n,1}$</p> $\phi M_{n,1} = \phi \times 5 \times \lambda \times \sqrt{f'_c} \times S_m$ $\phi M_{n,1} = 0.65 \times 5 \times 1 \times \sqrt{(2.5 \text{ ksi})} \times 18432.001 \text{ in}^3$ $\phi M_{n,1} = 249.600 \text{ kip ft}$ <p>$\phi M_{n,2}$</p> $\phi M_{n,2} = \phi \times 0.85 \times f'_c \times S_m$	

$\phi M_{n,2} = \phi F_y Z_{xk} S_m$

$$\phi M_{n,2} = (0.65) \times 0.85 \times (2.5 \text{ ksi}) \times (18432 \text{ in}^3)$$

$$\phi M_{n,2} = 2121.6 \text{ kipft}$$

Therefore,

ϕM_n - Allowable flexural strength,

$$\phi M_n = \text{MIN}[\phi M_{n,1}, \phi M_{n,2}]$$

$$\phi M_n = \text{MIN}[(249.6 \text{ kipft}), (2121.6 \text{ kipft})]$$

$$\phi M_n = 249.6 \text{ kipft}$$

Considering x-direction:

$M_{max} = 15.762 \text{ kipft}$ - Maximum moment in the x-direction,

Ratio - Capacity

$$\text{Ratio} = \frac{M_{max}}{\phi M_n}$$

$$\text{Ratio} = \frac{(15.762 \text{ kipft})}{(249.6 \text{ kipft})}$$

$$\text{Ratio} = 0.063149$$

Status: **PASS**
Ratio: **0.060**