

Project Name: Walter Ward

Date: Thu Jun 26 2025

Location: 38094 Salmon Dr, Soldotna, AK 99669,
USA

Number of Modules: 18

Unique ID: 2P-17-8TOP-SD-57-L-3Hx6W-BB69

Number of Poles: 2

Dealer: _____

Date Sold:

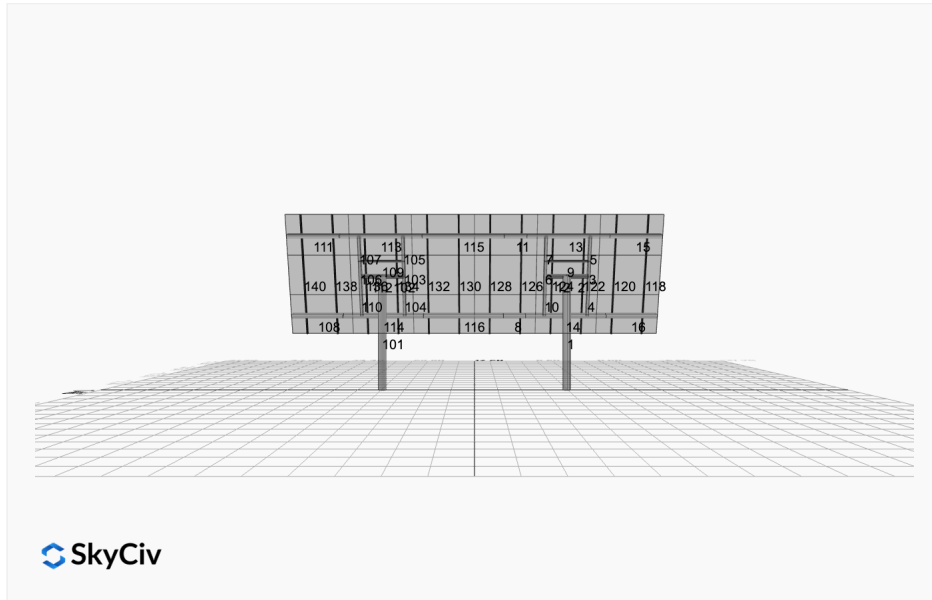

Array Dimensions N/S	11.28 ft
Array Dimensions E/W	34.40 ft
Winter Tilt Angle	75
Front Edge Clearance	5 ft

MT Solar Bill of Materials (2P-17-8TOP-SD-57-L-3Hx6W-BB69)

Part	Short Description	BOM Qty
MTS-PC-8	8IN Pole Cap Assembly	2
MTS-HF-SD	H-Frame Assembly-SD	2
MTS-SD-Wing-57	57IN SD Wing	4
MTS-SD-Splice-57	57IN SD Splice	4
MTS-CLAMP-HOOK-4PK	Hook Clamp	6

Rail Bill of Materials

Part	Qty
Rails (135in)	12
Rail Attachment	24
Module Mid Clamp	24
Module End Clamp	24
Ground Lug	6

Site Details:



Site Address: 38094 Salmon Dr, Soldotna, AK 99669, USA

Array Specification

Duty Classification:	SD
Module Width:	44.60 in
Module Length:	67.80in
Number of Rows:	3
Number of Columns:	6
Total Number of Modules:	18
Winter Tilt Angle:	75
Front Edge Clearance:	5
Total Array Height at Tilt:	15.89 ft
Total Frame Length:	34.00 ft
Module Info/Notes:	Hyundai 440 HIN-T440NF (BK)
Array Dimensions N/S:	11.28 ft
Array Dimensions E/W:	34.40 ft
Rail Length:	135.30 in
Rail Spacing:	2.87 ft

Support Specifications

Pole Size:	8in Pipe Sch 40
Pole Length above Grade:	10.45 ft
Number of Poles:	2
Pole Spacing:	17 ft

Foundation Specifications

Foundation Type:	Square
Foundation Dimensions:	48 x 48 in
Foundation Depth (below grade):	Pile 1: 7.00 ft Pile 2: 7.00 ft
Foundation Volume:	8.296 y ³

Site Info

Risk Category:	I
Exposure:	B
Soil Classification:	sand
Site Location:	38094 Salmon Dr, Soldotna, AK 99669, USA
Wind Speed:	130 mph
Snow Load:	83 psf

Design Disclaimer

This software should be used for preliminary designs and should not be used as a final design unless reviewed, verified and designed by a qualified structural engineer.

AutoDesigner Input

```
{ "product_type": "Beam", "designer_name": "Jordan Buetow", "designer_email": "jordan@aksolarpower.com", "designer_phone": "9079789493", "project_id": "Walter Ward", "site_address": "38094 Salmon Dr, Soldotna, AK 99669, USA", "module_info": "Hyundai 440 HIN-T440NF (BK)", "module_width": 44.6, "module_length": 67.8, "number_rows": 3, "number_columns": 6, "pole_mount_section": "4_40", "core_pipe_width": 65, "core_pipe_section": "2_40", "adjuster_section": "2_40", "core_beam_height": 65, "core_beam_section": "HSS3x2x1/8", "main_pipe_section": "2_12GA", "pole_spacing": 15, "tilt_angle": 75, "ground_clearance": 5, "risk_category": "I", "exposure_category": "B", "frame_duty_override": "auto", "pole_override": "auto", "soil_type": "sand", "customer_foundation_override": "48_Square", "foundation_type": "Square", "foundation_size": 48, "check_rails": false, "wind_speed_override": 130, "snow_load_override": 83, "direct_snow_load": false, "add_angle_brace": false }
```

Design Notes:

- AISC Deflection checks are set to L/1 due to structure design intent
- Foundation Soil Parameters used in this Autodesign are all estimates, proper geotechnical reports are required to confirm soil profiles
- Wind speeds, snow loads and other site specific results are based on ASCE 7 2016
- Steel frame design checks are based on AISC 360 2016 (LRFD)
- Foundation Design and Sizing is approximate only

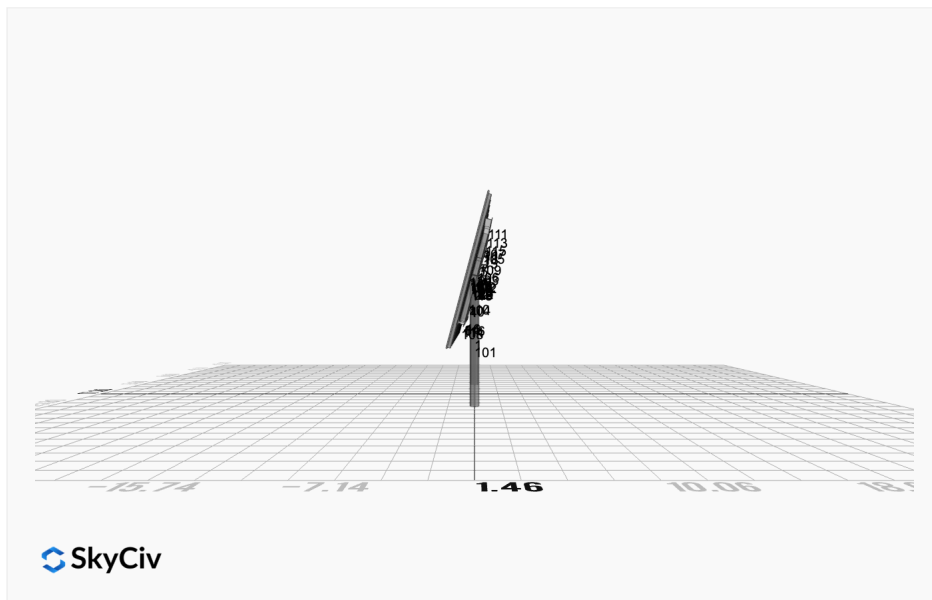
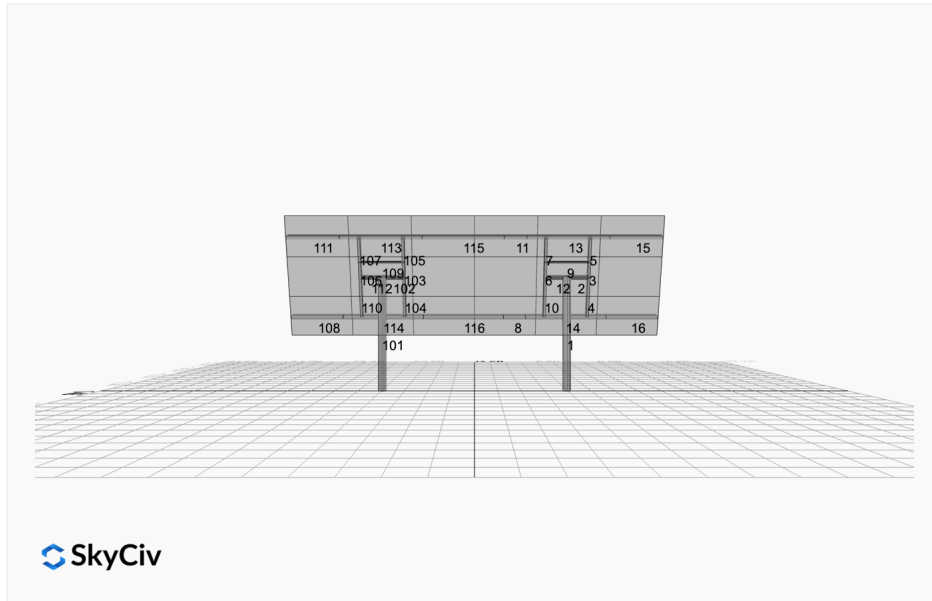

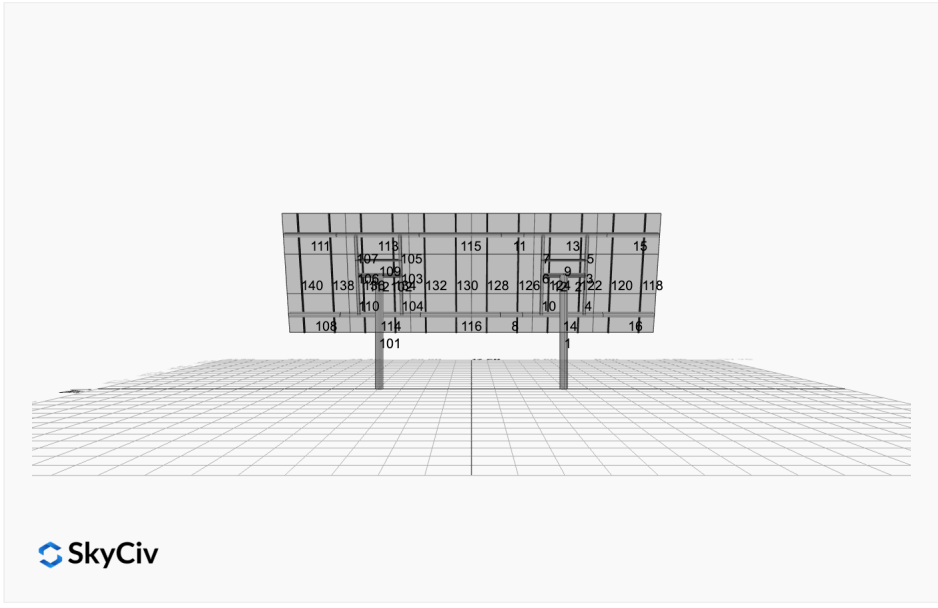
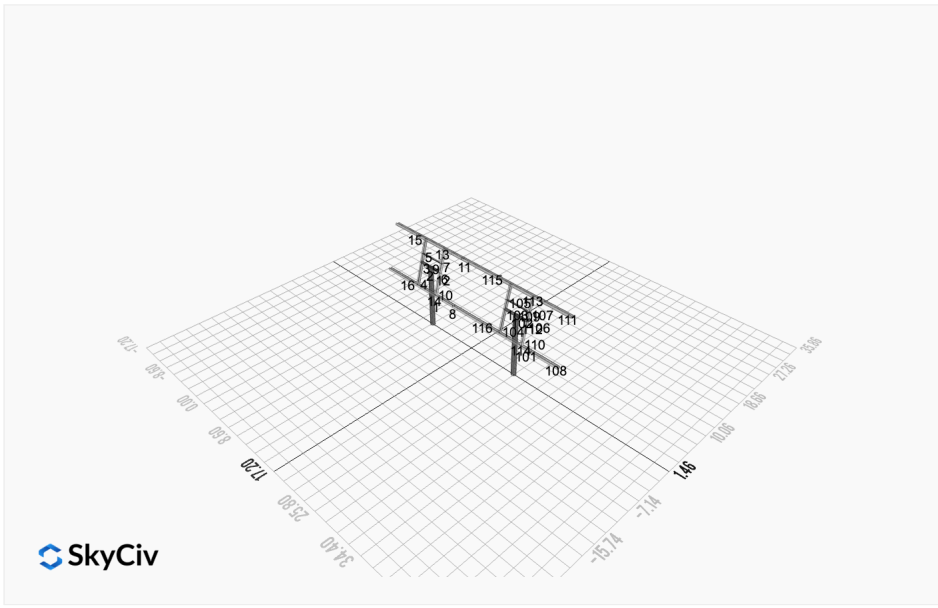
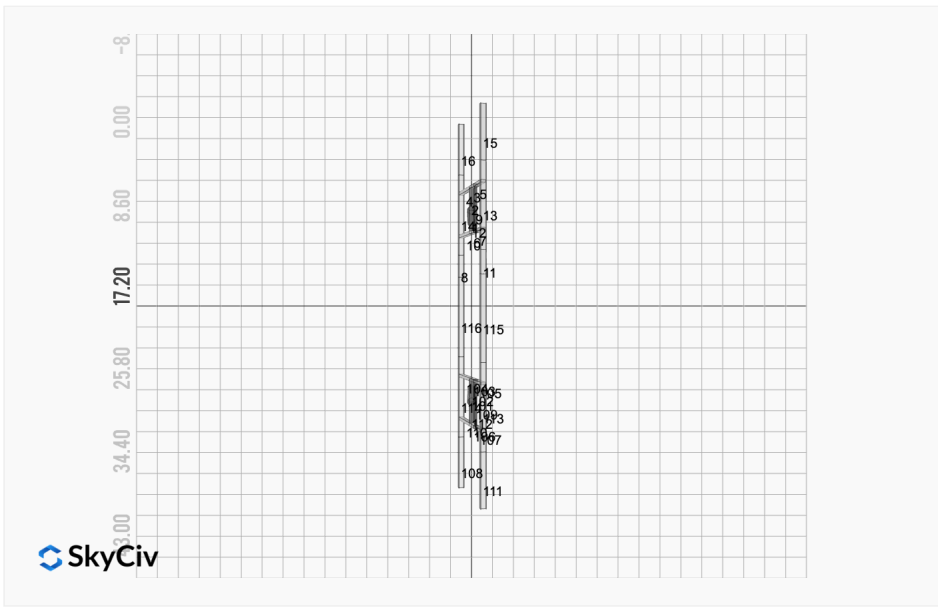

FEM Results (Envelope Worst Case for each member)

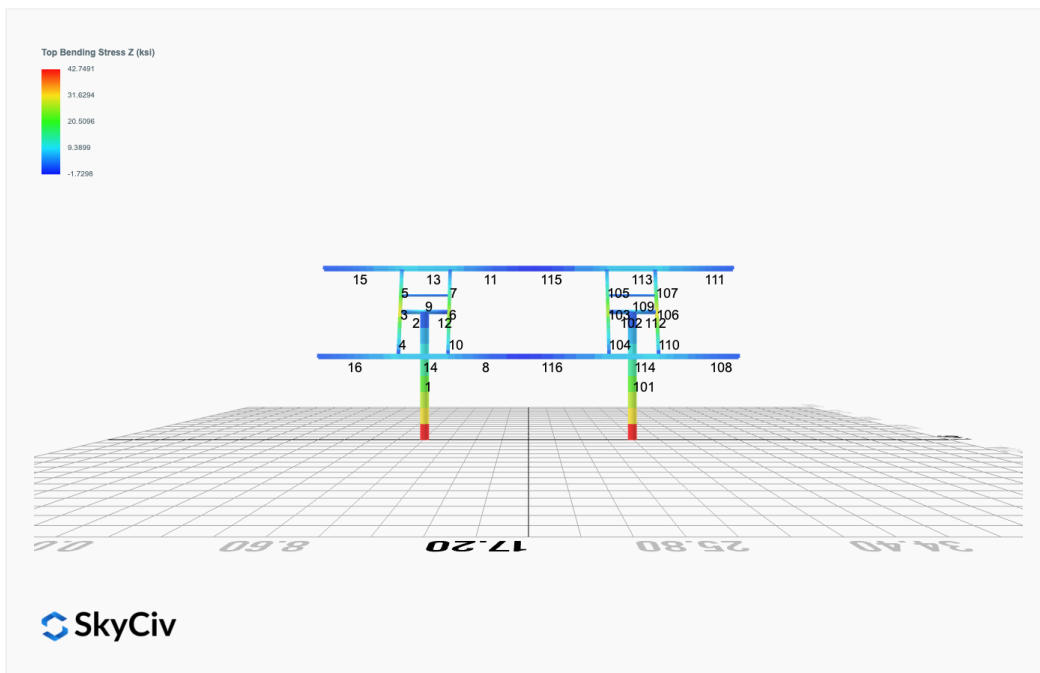
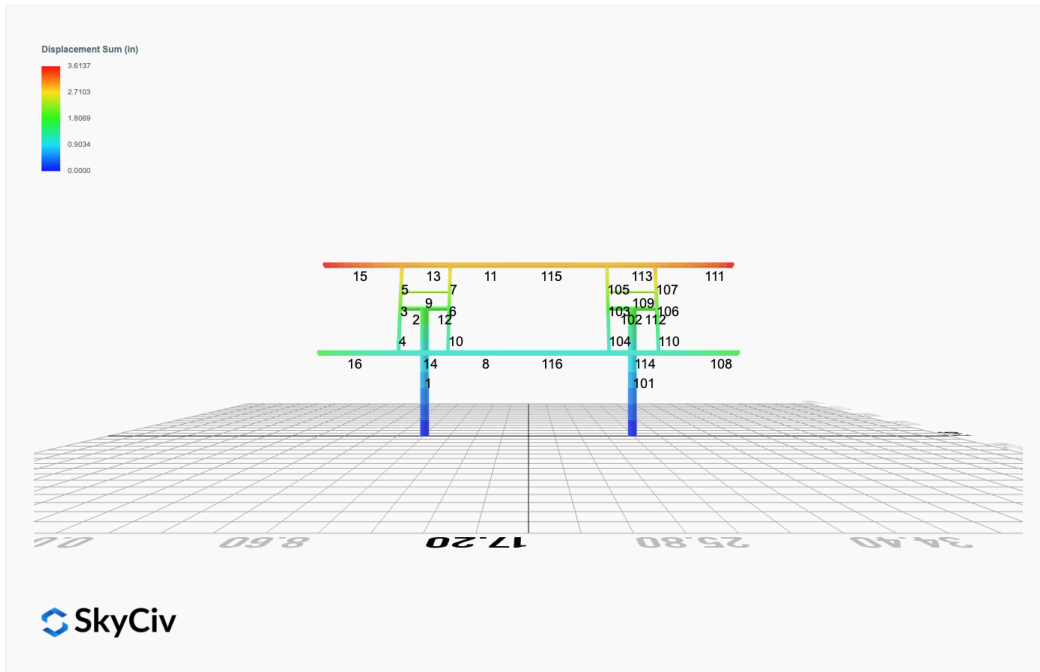

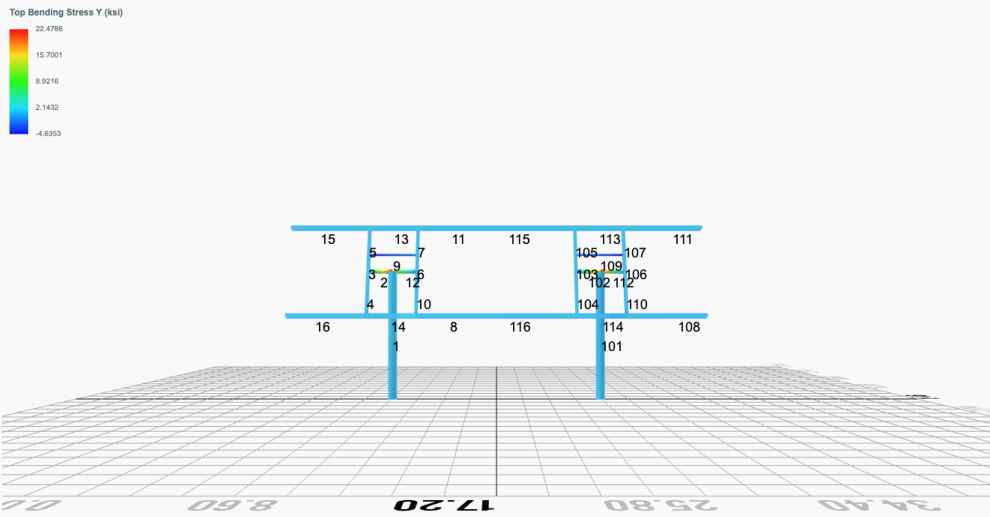

SkyCiv

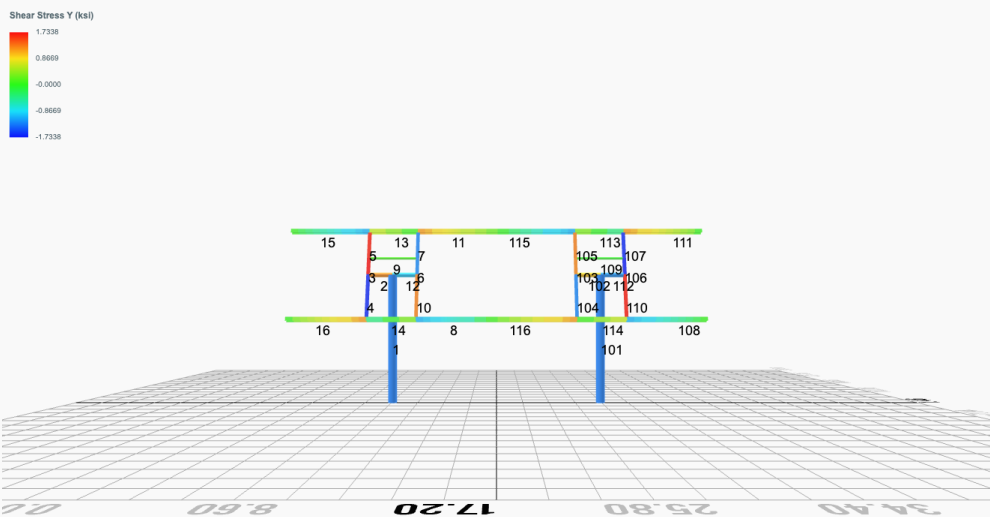

SkyCiv

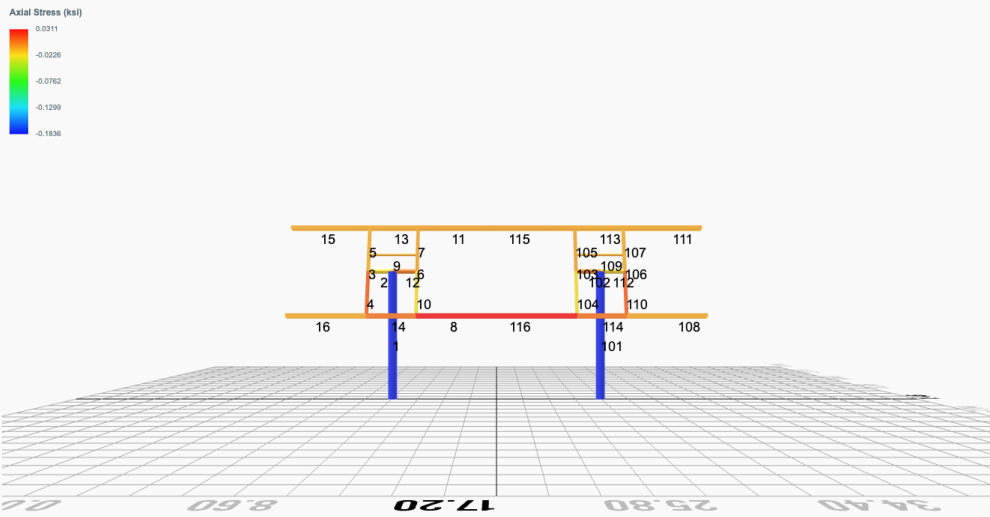

Reaction Forces for Foundation 1 (Node ID#1), (kip, kip-ft)

ASD Load Combination Results

Name	Fx	Fy	Fz	Mx	My	Mz
ULS: 1. D	0.0000	1.7125	-0.0173	-0.0516	0.0622	0.0063
ULS: 2. D + L	0.0000	1.7125	-0.0173	-0.0516	0.0622	0.0063
ULS: 3. D + (S or Lr or R)	0.0000	1.7125	-0.0173	-0.0516	0.0622	0.0063
ULS: 3. D + (S or Lr or R)	0.0000	1.7125	-0.0173	-0.0516	0.0622	0.0063
ULS: 4. D + 0.75L + 0.75(S or Lr or R)	0.0000	1.7125	-0.0173	-0.0516	0.0622	0.0063
ULS: 4. D + 0.75L + 0.75(S or Lr or R)	0.0000	1.7125	-0.0173	-0.0516	0.0622	0.0063
ULS: 5b. D + 0.7E	0.0000	1.7125	-0.0173	-0.0516	0.0622	0.0063
ULS: 6b. D + 0.75L + 0.75(0.7)E + 0.75S	0.0000	1.7125	-0.0173	-0.0516	0.0622	0.0063
ULS: 8. 0.6D + 0.7E	0.0000	1.0275	-0.0104	-0.0310	0.0373	0.0038
ULS: 5a. D + 0.6W_Wind downforce Case A only	-3.4529	2.6377	-0.0709	-0.1923	0.9405	36.2123
ULS: 5a. D + 0.6W_Wind downforce Case B only	0.0000	1.7125	-0.0173	-0.0516	0.0622	0.0063
ULS: 5a. D + 0.6W_Wind uplift Case A only	3.4529	0.7873	0.0363	0.0890	-0.8165	-35.9223
ULS: 5a. D + 0.6W_Wind uplift Case B only	0.0000	1.7125	-0.0173	-0.0516	0.0622	0.0063
ULS: 6a. D + 0.75L + 0.75(0.6)W + 0.75(S or Lr or R)_Wind downforce Case A only	-2.5897	2.4064	-0.0575	-0.1572	0.7209	27.1608
ULS: 6a. D + 0.75L + 0.75(0.6)W + 0.75(S or Lr or R)_Wind downforce Case B only	0.0000	1.7125	-0.0173	-0.0516	0.0622	0.0063
ULS: 6a. D + 0.75L + 0.75(0.6)W + 0.75(S or Lr or R)_Wind uplift Case A only	2.5897	1.0186	0.0229	0.0539	-0.5968	-26.9402
ULS: 6a. D + 0.75L + 0.75(0.6)W + 0.75(S or Lr or R)_Wind uplift Case B only	0.0000	1.7125	-0.0173	-0.0516	0.0622	0.0063
ULS: 6a. D + 0.75L + 0.75(0.6)W + 0.75(S or Lr or R)_Wind downforce Case A only	-2.5897	2.4064	-0.0575	-0.1572	0.7209	27.1608
ULS: 6a. D + 0.75L + 0.75(0.6)W + 0.75(S or Lr or R)_Wind downforce Case B only	0.0000	1.7125	-0.0173	-0.0516	0.0622	0.0063
ULS: 6a. D + 0.75L + 0.75(0.6)W + 0.75(S or Lr or R)_Wind uplift Case A only	2.5897	1.0186	0.0229	0.0539	-0.5968	-26.9402
ULS: 6a. D + 0.75L + 0.75(0.6)W + 0.75(S or Lr or R)_Wind uplift Case B only	0.0000	1.7125	-0.0173	-0.0516	0.0622	0.0063
ULS: 7. 0.6D + 0.6W_Wind downforce Case A only	-3.4529	1.9527	-0.0640	-0.1717	0.9156	36.2098
ULS: 7. 0.6D + 0.6W_Wind downforce Case B only	0.0000	1.0275	-0.0104	-0.0310	0.0373	0.0038
ULS: 7. 0.6D + 0.6W_Wind uplift Case A only	3.4529	0.1023	0.0432	0.1096	-0.8414	-35.9249
ULS: 7. 0.6D + 0.6W_Wind uplift Case B only	0.0000	1.0275	-0.0104	-0.0310	0.0373	0.0038

Worst Case Reactions LRFD

These calculations are taken directly from the FEA via SkyCiv and are used in the Concrete Checks of the Foundation Module.

Note: Worst case values are assumed as downforce wind load cases.

Result	Value (kip, kip-ft)
Axial	3.5970
Shear X	-5.7548
Shear Z	-0.1101
Moment X	-0.2966
Moment Y (Twist)	1.5370
Moment Z	60.6984

Worst Case Reactions ASD

These results are taken from the worst case values in the above table and are used in the Soil Checks in the Foundation Module.

Note: Worst case values are assumed as downforce wind load cases.

Result	Value (kip, kip-ft)
Axial	2.6377
Shear X	-3.4529
Shear Z	-0.0709
Moment X	-0.1923
Moment Y (Twist)	0.9405
Moment Z	36.2123

Reaction Forces for Foundation 2 (Node ID#101), (kip, kip-ft)

ASD Load Combination Results

Name	Fx	Fy	Fz	Mx	My	Mz
ULS: 1. D	-0.0000	1.7125	0.0173	0.0516	-0.0622	0.0063
ULS: 2. D + L	-0.0000	1.7125	0.0173	0.0516	-0.0622	0.0063
ULS: 3. D + (S or Lr or R)	-0.0000	1.7125	0.0173	0.0516	-0.0622	0.0063
ULS: 3. D + (S or Lr or R)	-0.0000	1.7125	0.0173	0.0516	-0.0622	0.0063
ULS: 4. D + 0.75L + 0.75(S or Lr or R)	-0.0000	1.7125	0.0173	0.0516	-0.0622	0.0063

Name	Fx	Fy	Fz	Mx	My	Mz
ULS: 4. D + 0.75L + 0.75(S or Lr or R)	-0.0000	1.7125	0.0173	0.0516	-0.0622	0.0063
ULS: 5b. D + 0.7E	-0.0000	1.7125	0.0173	0.0516	-0.0622	0.0063
ULS: 6b. D + 0.75L + 0.75(0.7)E + 0.75S	-0.0000	1.7125	0.0173	0.0516	-0.0622	0.0063
ULS: 8. 0.6D + 0.7E	-0.0000	1.0275	0.0104	0.0310	-0.0373	0.0038
ULS: 5a. D + 0.6W_Wind downforce Case A only	-3.4529	2.6377	0.0709	0.1923	-0.9405	36.2123
ULS: 5a. D + 0.6W_Wind downforce Case B only	-0.0000	1.7125	0.0173	0.0516	-0.0622	0.0063
ULS: 5a. D + 0.6W_Wind uplift Case A only	3.4529	0.7873	-0.0363	-0.0890	0.8165	-35.9223
ULS: 5a. D + 0.6W_Wind uplift Case B only	-0.0000	1.7125	0.0173	0.0516	-0.0622	0.0063
ULS: 6a. D + 0.75L + 0.75(0.6)W + 0.75(S or Lr or R)_Wind downforce Case A only	-2.5897	2.4064	0.0575	0.1572	-0.7209	27.1608
ULS: 6a. D + 0.75L + 0.75(0.6)W + 0.75(S or Lr or R)_Wind downforce Case B only	-0.0000	1.7125	0.0173	0.0516	-0.0622	0.0063
ULS: 6a. D + 0.75L + 0.75(0.6)W + 0.75(S or Lr or R)_Wind uplift Case A only	2.5897	1.0186	-0.0229	-0.0538	0.5968	-26.9402
ULS: 6a. D + 0.75L + 0.75(0.6)W + 0.75(S or Lr or R)_Wind uplift Case B only	-0.0000	1.7125	0.0173	0.0516	-0.0622	0.0063
ULS: 6a. D + 0.75L + 0.75(0.6)W + 0.75(S or Lr or R)_Wind downforce Case A only	-2.5897	2.4064	0.0575	0.1572	-0.7209	27.1608
ULS: 6a. D + 0.75L + 0.75(0.6)W + 0.75(S or Lr or R)_Wind downforce Case B only	-0.0000	1.7125	0.0173	0.0516	-0.0622	0.0063
ULS: 6a. D + 0.75L + 0.75(0.6)W + 0.75(S or Lr or R)_Wind uplift Case A only	2.5897	1.0186	-0.0229	-0.0538	0.5968	-26.9402
ULS: 6a. D + 0.75L + 0.75(0.6)W + 0.75(S or Lr or R)_Wind uplift Case B only	-0.0000	1.7125	0.0173	0.0516	-0.0622	0.0063
ULS: 7. 0.6D + 0.6W_Wind downforce Case A only	-3.4529	1.9527	0.0640	0.1717	-0.9156	36.2098
ULS: 7. 0.6D + 0.6W_Wind downforce Case B only	-0.0000	1.0275	0.0104	0.0310	-0.0373	0.0038
ULS: 7. 0.6D + 0.6W_Wind uplift Case A only	3.4529	0.1023	-0.0432	-0.1096	0.8414	-35.9249
ULS: 7. 0.6D + 0.6W_Wind uplift Case B only	-0.0000	1.0275	0.0104	0.0310	-0.0373	0.0038

Worst Case Reactions LRFD

These calculations are taken directly from the FEA via SkyCiv and are used in the Concrete Checks of the Foundation Module.
Note: Worst case values are assumed as downforce wind load cases.

Result	Value (kip, kip-ft)
Axial	3.5970
Shear X	-5.7548
Shear Z	0.1101
Moment X	0.2966
Moment Y (Twist)	1.5371
Moment Z	60.6992

Worst Case Reactions ASD

These results are taken from the worst case values in the above table and are used in the Soil Checks in the Foundation Module.
Note: Worst case values are assumed as downforce wind load cases.

Result	Value (kip, kip-ft)
Axial	2.6377
Shear X	-3.4529
Shear Z	0.0709
Moment X	0.1923
Moment Y (Twist)	0.9405
Moment Z	36.2123

Project Details

Design Code: AISC 360-16 LRFD
 Provision: LRFD
 Country: United States
 User Name: sales@mtsolar.us
 Unit System: imperial



Design Input Information

Design Factors			
Φ_t	Φ_c	Φ_b	Φ_v
0.9	0.9	0.9	0.9

Design Materials			
ID	E (ksi)	F_y (ksi)	F_u (ksi)
1	29000	50	65

Section Dimensions

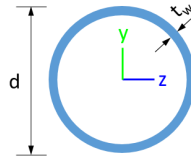

ID	Name	d (in)	t_w (in)				
1	2in Pipe Sch 40	2.38	0.15				
4	4in Pipe Sch 40	4.50	0.24				
9	8in Pipe Sch 40	8.63	0.32				

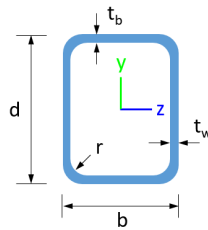

ID	Name	d (in)	b (in)	t_w (in)	t_b (in)	r (in)	
15	HSS5x3x1/8	5.00	3.00	0.12	0.12	0.12	

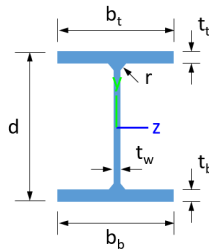

ID	Name	d (in)	t_w (in)	b_t (in)	b_b (in)	t_t (in)	t_b (in)	r (in)
18	W6x9	5.90	0.17	3.94	3.94	0.21	0.21	0.25

Section Properties

ID	Name	A (in ²)	J (in ⁴)	I_{yp} (in ⁴)	I_{zp} (in ⁴)	I_w (in ⁶)	S_{yp} (in ³)	S_{zp} (in ³)
----	------	----------------------	----------------------	-----------------------------	-----------------------------	--------------------------	-----------------------------	-----------------------------

5	0.007	0.372	0.117	0.060	0.022	0.395	#13	0.073	Not Required	Pass
6	0.006	0.495	0.038	0.049	0.004	0.527	#13	0.044	Not Required	Pass
7	0.005	0.308	0.082	0.050	0.017	0.327	#13	0.073	Not Required	Pass
8	0.001	0.054	0.034	0.029	0.005	0.076	#13	0.088	Not Required	Pass
9	0.005	0.028	0.084	0.002	0.002	0.102	#13	0.198	Not Required	Pass
10	0.005	0.492	0.081	0.049	0.015	0.561	#13	0.078	Not Required	Pass
11	0.001	0.053	0.033	0.029	0.005	0.076	#13	0.059	Not Required	Pass
12	0.001	0.127	0.287	0.033	0.060	0.415	#13	0.034	Not Required	Pass
13	0.003	0.204	0.165	0.040	0.007	0.345	#13	0.177	Not Required	Pass
14	0.004	0.208	0.165	0.040	0.007	0.345	#13	0.177	Not Required	Pass
15	0.000	0.090	0.088	0.029	0.005	0.166	#13	Not Required	Not Required	Pass
16	0.000	0.090	0.088	0.029	0.005	0.166	#13	Not Required	Not Required	Pass
101	0.017	0.729	0.010	0.051	0.001	0.741	#13	0.448	Not Required	Pass
102	0.001	0.127	0.287	0.033	0.060	0.415	#13	0.034	Not Required	Pass
103	0.006	0.495	0.038	0.049	0.004	0.527	#13	0.044	Not Required	Pass
104	0.005	0.492	0.081	0.049	0.015	0.561	#13	0.078	Not Required	Pass
105	0.005	0.308	0.082	0.050	0.017	0.327	#13	0.073	Not Required	Pass
106	0.007	0.600	0.056	0.061	0.010	0.654	#13	0.044	Not Required	Pass
107	0.007	0.372	0.117	0.060	0.022	0.395	#13	0.073	Not Required	Pass
108	0.000	0.090	0.088	0.029	0.005	0.166	#13	Not Required	Not Required	Pass
109	0.005	0.028	0.084	0.002	0.002	0.102	#13	0.198	Not Required	Pass
110	0.006	0.598	0.112	0.060	0.019	0.652	#13	0.078	Not Required	Pass
111	0.000	0.090	0.088	0.029	0.005	0.166	#13	Not Required	Not Required	Pass
112	0.001	0.180	0.382	0.042	0.074	0.562	#13	0.034	Not Required	Pass
113	0.003	0.204	0.165	0.040	0.007	0.345	#13	0.177	Not Required	Pass
114	0.004	0.208	0.165	0.040	0.007	0.345	#13	0.265	Not Required	Pass
115	0.001	0.053	0.061	0.029	0.005	0.091	#13	0.214	Not Required	Pass
116	0.002	0.054	0.062	0.029	0.005	0.090	#13	0.321	Not Required	Pass

Definitions

Φ_t	Safety factor for tensile
Φ_c	Safety factor for compression
Φ_b	Safety factor for flexure
Φ_v	Safety factor for shear
E	Modulus of elasticity
F_y	Specified minimum yield stress
F_u	Specified minimum tensile strength
A	Cross-sectional area
J	Torsional constant
I_{yp}	Moment of inertia about the Y axes
I_{zp}	Moment of inertia about the Z axes
I_w	Warping constant
S_{yp}	Plastic section modulus about the Y axis
S_{zp}	Plastic section modulus about the Z axis
KL	Effective length
C_b	Buckling modification factor (from all load combinations)
L_b	Length between braced points
LST	Limited slenderness for tension
LSC	Limited slenderness for compression
LD	Limited deflection
P_n	Nominal axial strength (tension/compression)
M_n	Nominal flexural strength (about Z/Y axis)
V_n	Nominal shear strength (along Z/Y axis)
P	Design ratio in case of axial force
M_z	Design ratio in case of bending about Z axis
M_y	Design ratio in case of bending about Y axis
V_y	Design ratio in case of shear along Y axis
V_z	Design ratio in case of shear along Z axis

(P,M _z ,M _y)	Design ratio in case of axial force and bending action
KL/r	Design ratio in case of section slenderness
δ	Design ratio in case of member deflection
OK	Capacity is provided
NG	Capacity is not provided

REFERENCES	CALCULATIONS	RESULTS
------------	--------------	---------

SkyCiv Foundation Design

Pile Foundation

Design Information :

Design code : IBC 2021 (International Building Code)
Unit System : Imperial

Pile Input

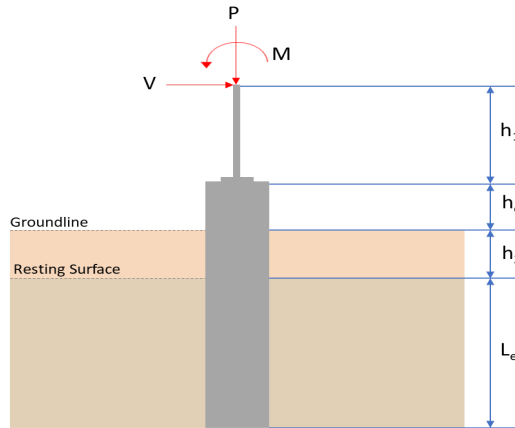

Geometry

Pile shape: rectangular

$b = 48$ in - Pile width

$D = 48$ in - Pile depth

$L = 7$ ft - Total pile length

$h_1 = 0$ ft - Lateral load height from the top of the pile,

$h_2 = 0$ ft - Depth to resisting surface

$h_e = 0$ ft - Length of pile above the ground

Tabulation of Soil Parameters

Layer	Label	Allowable Bearing Pressure (q_a) (psf)	Allowable Lateral Pressure (R) (psf/ft)
1	Sand, silty sand, clayey sand, silty gravel & clayey gravel	2000.000	150.000

Tabulation of Loads

Load Component	ASD	LRFD
P (kip)	2.638	3.597
V_x (kip)	-3.453	-5.755
V_z (kip)	-0.071	-0.110
M_x (kipft)	-0.192	-0.297
M_z (kipft)	36.212	60.698

Material Properties

$f'_{ck} = 2.5$ ksi - Concrete strength.

Required depth to resist lateral loads (ASD)

H - Point of application of the lateral load

$$H = h_1 + h_2 + h_e$$

$$H = (0 \text{ ft}) + (0 \text{ ft}) + (0 \text{ ft})$$

$$H = 0 \text{ ft}$$

Considering x-direction:

H_o - Lateral force per length of pile,

$$H_o = \frac{V_x}{1.57 D}$$

$$H_o = \frac{(-3.453 \text{ kip})}{1.57 \times (48 \text{ in})}$$

$$H_o = -0.54984 \text{ kip/ft}$$

M_o - Moment per length of pile,

$$M_o = \frac{M_z + (V_x H)}{1.57 D}$$

$$M_o = \frac{(36.212 \text{ kipft}) + ((-3.453 \text{ kip}) \times (0 \text{ ft}))}{1.57 \times (48 \text{ in})}$$

$$M_o = 5.7662 \text{ kipft/ft}$$

Required depth of embedment in earth:

$$L_x^3 - \left(14.14 \times \frac{H_o \times L_x}{R} \right) - \left(18.85 \times \frac{M_o}{R} \right) = 0$$

Solving the cubic equation:

$L_{e,x} = 6.3224 \text{ ft}$ - Required depth in x-direction,

Considering z-direction:

H_o - Lateral force per length of pile,

$$H_o = \frac{V_z}{1.57 b}$$

$$H_o = \frac{(-0.071 \text{ kip})}{1.57 \times (48 \text{ in})}$$

$$H_o = -0.011306 \text{ kip/ft}$$

M_o - Moment per length of pile,

$$M_o = \frac{M_x + (V_z H)}{1.57 b}$$

$$M_o = \frac{(0.192 \text{ kipft}) + ((-0.071 \text{ kip}) \times (0 \text{ ft}))}{1.57 \times (48 \text{ in})}$$

$$M_o = 0.030573 \text{ kipft/ft}$$

Required depth of embedment in earth:

$$L_z^3 - \left(14.14 \times \frac{H_o \times L_z}{R} \right) - \left(18.85 \times \frac{M_o}{R} \right) = 0$$

Solving the cubic equation:

$L_{e,z} = 1.1804 \text{ ft}$ - Required depth in z-direction,

Minimum embedded depth required:

$L_{e,req}$ - Depth of pile required,

$$L_{e,req} = \text{MAX}[L_{e,x}, L_{e,z}]$$

$$L_{e,req} = \text{MAX}[(6.3224 \text{ ft}), (1.1804 \text{ ft})]$$

$$L_{e,req} = 6.322 \text{ ft}$$

L_e - Actual embedded length of pile,

$$L_e = L - h_e - h_2$$

$$L_e = (7 \text{ ft}) - (0 \text{ ft}) - (0 \text{ ft})$$

$$L_e = 7 \text{ ft}$$

Ratio - Embedded depth

$$\text{Ratio} = \frac{L_{e,req}}{L_e}$$

$$\text{Ratio} = \frac{(6.322 \text{ ft})}{(7 \text{ ft})}$$

$$\text{Ratio} = 0.90314$$

Status: **PASS**
Ratio: **0.900**

End-bearing Capacity (ASD)

A - Pile cross-section area

$$A = b D$$

$$A = (48 \text{ in}) \times (48 \text{ in})$$

$$A = 16 \text{ ft}^2$$

q - End-bearing pressure

$$q = \frac{P_v}{A}$$

$$q = \frac{(2.638 \text{ kip})}{(16 \text{ ft}^2)}$$

$$q = 0.16487 \text{ kip/ft}^2$$

Check bearing capacity ratio:

Ratio - Capacity

$$\text{Ratio} = \frac{q}{q_a}$$

$$\text{Ratio} = \frac{(0.16487 \text{ kip/ft}^2)}{(2000 \text{ psf})}$$

$$\text{Ratio} = 0.082437$$

Status: **PASS**
Ratio: **0.080**

Czerniak

Lateral Soil Pressure (ASD):

L/D - Length to least lateral dimension ratio,

$$L/D = \frac{L}{D}$$

$$L/D = \frac{(7 \text{ ft})}{(48 \text{ in})}$$

$$L/D = 1.75$$

Since $L/D \leq 10$,

Pile is short.

Considering x-direction:

$H_o = -0.54984 \text{ kip/ft}$ - Lateral force per length of pile,

$M_o = 5.7662 \text{ kipft/ft}$ - Overturning moment per length of pile,

a - Distance from resting surface to pivot point,

$$a = \frac{(4 M_o L_e) + (3 H_o L_e^2)}{(6 M_o) + (4 H_o L_e)}$$

$$a = \frac{(4 \times (5.7662 \text{ kipft/ft}) \times (7 \text{ ft})) + (3 \times (-0.54984 \text{ kip/ft}) \times (7 \text{ ft})^2)}{(6 \times (5.7662 \text{ kipft/ft})) + (4 \times (-0.54984 \text{ kip/ft}) \times (7 \text{ ft}))}$$

$$a = 4.8463 \text{ ft}$$

p - Earth pressure against the pile at distance $a/2$ from resting surface,

$$p = \frac{0.75 [(4 M_o) + (3 H_o L_e)]^2}{L_e^2 [(3 M_o) + (2 H_o L_e)]}$$

$$p = \frac{0.75 \times [(4 \times (5.7662 \text{ kipft/ft})) + (3 \times (-0.54984 \text{ kip/ft}) \times (7 \text{ ft}))]^2}{(7 \text{ ft})^2 \times [(3 \times (5.7662 \text{ kipft/ft})) + (2 \times (-0.54984 \text{ kip/ft}) \times (7 \text{ ft}))]}$$

$$p = 0.21151 \text{ kip/ft}^2$$

s - Earth pressure against the pile at distance L_e ,

$$s = \frac{6 [(2 M_o) + (H_o L_e)]}{L_e^2}$$

$$s = \frac{6 \times [(2 \times (5.7662 \text{ kipft/ft})) + ((-0.54984 \text{ kip/ft}) \times (7 \text{ ft}))]}{(7 \text{ ft})^2}$$

$$s = 0.94085 \text{ kip/ft}^2$$

Check lateral soil pressure capacity:

p_a - Allowable lateral soil pressure at depth $a/2$,

$$p_a = R \frac{a}{2}$$

$$p_a = (150 \text{ psf/ft}) \times \frac{(4.8463 \text{ ft})}{2}$$

$$p_a = 0.36347 \text{ kip/ft}^2$$

Ratio - Lateral soil capacity

$$Ratio = \frac{p}{p_a}$$

$$Ratio = \frac{(0.21151 \text{ kip/ft}^2)}{(0.36347 \text{ kip/ft}^2)}$$

$$Ratio = 0.58191$$

p_s - Allowable lateral soil pressure at depth L_e ,

$$p_s = R L_e$$

$$p_s = (150 \text{ psf/ft}) \times (7 \text{ ft})$$

$$p_s = 1.05 \text{ kip/ft}^2$$

Ratio - Lateral soil capacity

$$Ratio = \frac{s}{p_s}$$

$$Ratio = \frac{(0.94085 \text{ kip/ft}^2)}{(1.05 \text{ kip/ft}^2)}$$

$$Ratio = 0.89605$$

Status: **PASS**
Ratio: **0.580**

Status: **PASS**
Ratio: **0.900**

Considering z-direction:

$H_o = -0.011306 \text{ kip/ft}$ - Lateral force per length of pile,

$M_o = 0.030573 \text{ kipft/ft}$ - Overturning moment per length of pile,

a - Distance from resting surface to pivot point,

$$a = \frac{(4 M_o L_e) + (3 H_o L_e^2)}{(6 M_o) + (4 H_o L_e)}$$

$$a = \frac{(4 \times (0.030573 \text{ kipft/ft}) \times (7 \text{ ft})) + (3 \times (-0.011306 \text{ kip/ft}) \times (7 \text{ ft})^2)}{(6 \times (0.030573 \text{ kipft/ft})) + (4 \times (-0.011306 \text{ kip/ft}) \times (7 \text{ ft}))}$$

$$a = 5.036 \text{ ft}$$

p - Earth pressure against the pile at distance $a/2$ from resting surface,

$$p = \frac{0.75 [(4 M_o) + (3 H_o L_e)]^2}{L_e^2 [(3 M_o) + (2 H_o L_e)]}$$

$$p = \frac{0.75 [(4 \times (0.030573 \text{ kipft/ft})) + (3 \times (-0.011306 \text{ kip/ft}) \times (7 \text{ ft}))]^2}{(7 \text{ ft})^2 [(3 \times (0.030573 \text{ kipft/ft})) + (2 \times (-0.011306 \text{ kip/ft}) \times (7 \text{ ft}))]}$$

$$p = -0.0030479 \text{ kip/ft}^2$$

s - Earth pressure against the pile at distance L_e ,

$$s = \frac{6 [(2 M_o) + (H_o L_e)]}{L_e^2}$$

$$s = \frac{6 \times [(2 \times (0.030573 \text{ kipft/ft})) + ((-0.011306 \text{ kip/ft}) \times (7 \text{ ft}))]}{(7 \text{ ft})^2}$$

$$s = -0.0022033 \text{ kip/ft}^2$$

Check lateral soil pressure capacity:

p_a - Allowable lateral soil pressure at depth $a/2$,

$$p_a = R \frac{a}{2}$$

$$p_a = (150 \text{ psf/ft}) \times \frac{(5.036 \text{ ft})}{2}$$

$$p_a = 0.3777 \text{ kip/ft}^2$$

Ratio - Lateral soil capacity

$$Ratio = \frac{p}{p_a}$$

$$Ratio = \frac{(-0.0030479 \text{ kip/ft}^2)}{(0.3777 \text{ kip/ft}^2)}$$

$$Ratio = -0.0080697$$

p_s - Allowable lateral soil pressure at depth L_e ,

$$p_s = R L_e$$

$$p_s = (150 \text{ psf/ft}) \times (7 \text{ ft})$$

$$p_s = 1.05 \text{ kip/ft}^2$$

Ratio - Lateral soil capacity

$$Ratio = \frac{s}{p_s}$$

$$Ratio = \frac{(-0.0022033 \text{ kip/ft}^2)}{(1.05 \text{ kip/ft}^2)}$$

$$Ratio = -0.0020984$$

Status: **PASS**
Ratio: **-0.010**

Status: **PASS**
Ratio: **0.000**

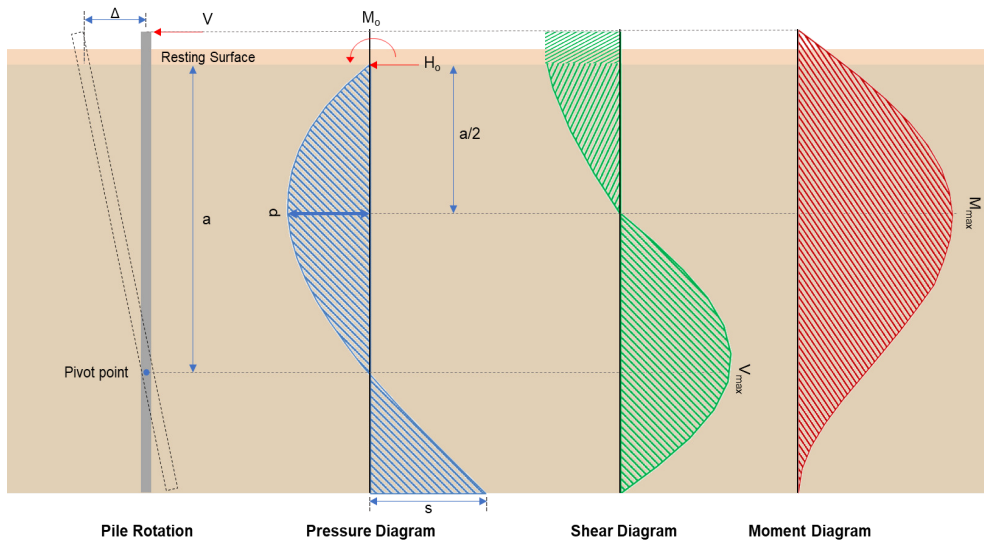

Shear force and Bending moment (x-direction, LRFD)

H_o - Lateral force per length of pile,

$$H_o = \frac{V_x}{1.57 D}$$

$$H_o = \frac{(-5.755 \text{ kip})}{1.57 \times (48 \text{ in})}$$

$$H_o = -0.9164 \text{ kip/ft}$$

M_o - Moment per length of pile,

$$M_o = \frac{M_z + (V_x H)}{1.57 D}$$

$$M_o = \frac{(60.698 \text{ kipft}) + ((-5.755 \text{ kip}) \times (0 \text{ ft}))}{1.57 \times (48 \text{ in})}$$

$$M_o = 9.6653 \text{ kipft/ft}$$

E - Distance from lateral load to resisting surface,

$$E = \frac{M_o}{H_o}$$

$$E = \frac{(9.6653 \text{ kipft/ft})}{(-0.9164 \text{ kip/ft})}$$

$$E = 10.547 \text{ ft}$$

a - Distance from resting surface to pivot point,

$$a = \frac{(4 M_o L_e) + (3 H_o L_e^2)}{(6 M_o) + (4 H_o L_e)}$$

$$a = \frac{(4 \times (9.6653 \text{ kipft/ft}) \times (7 \text{ ft})) + (3 \times (-0.9164 \text{ kip/ft}) \times (7 \text{ ft})^2)}{6 \times (9.6653 \text{ kipft/ft}) + 4 \times (-0.9164 \text{ kip/ft}) \times (7 \text{ ft})}$$

$$a = \frac{(6 \times (9.6653 \text{ kipft/ft})) + (4 \times (-0.9164 \text{ kip/ft}) \times (7 \text{ ft}))}{}$$

$$a = 4.8456 \text{ ft}$$

V_{max} - Max shear force located at depth a ,

$$V_{max} = (H_o D) \left[1 - \left[3 \left(\frac{4E}{L_e} + 3 \right) \left(\frac{a}{L_e} \right)^2 \right] + \left[4 \left(\frac{3E}{L_e} + 2 \right) \left(\frac{a}{L_e} \right)^3 \right] \right]$$

$$V_{max} = ((-0.9164 \text{ kip/ft}) \times (48 \text{ in})) \times \left[1 - \left[3 \times \left(\frac{4 \times (10.547 \text{ ft})}{(7 \text{ ft})} + 3 \right) \times \left(\frac{(4.8456 \text{ ft})}{(7 \text{ ft})} \right)^2 \right] + \left[4 \times \left(\frac{3 \times (10.547 \text{ ft})}{(7 \text{ ft})} + 2 \right) \times \left(\frac{(4.8456 \text{ ft})}{(7 \text{ ft})} \right)^3 \right] \right]$$

$$V_{max} = 12.19 \text{ kip}$$

M_{max} - Max bending moment located at depth $a/2$,

$$M_{max} = (H_o D L_e) \left[\left(\frac{E}{L_e} + \frac{a}{2 L_e} \right) - \left[\left(\frac{4E}{L_e} + 3 \right) \left(\frac{a}{2 L_e} \right)^3 \right] + \left[\left(\frac{3E}{L_e} + 2 \right) \left(\frac{a}{2 L_e} \right)^4 \right] \right]$$

$$M_{max} = ((-0.9164 \text{ kip/ft}) \times (48 \text{ in}) \times (7 \text{ ft})) \times \left[\left(\frac{(10.547 \text{ ft})}{(7 \text{ ft})} + \frac{(4.8456 \text{ ft})}{2 \times (7 \text{ ft})} \right) - \left[\left(\frac{4 \times (10.547 \text{ ft})}{(7 \text{ ft})} + 3 \right) \times \left(\frac{(4.8456 \text{ ft})}{2 \times (7 \text{ ft})} \right)^3 \right] + \left[\left(\frac{3 \times (10.547 \text{ ft})}{(7 \text{ ft})} + 2 \right) \times \left(\frac{(4.8456 \text{ ft})}{2 \times (7 \text{ ft})} \right)^4 \right] \right]$$

$$M_{max} = 40.339 \text{ kipft}$$

Shear force and Bending moment (z-direction, LRFD)

H_o - Lateral force per length of pile,

$$H_o = \frac{V_z}{1.57 b}$$

$$H_o = \frac{(-0.11 \text{ kip})}{1.57 \times (48 \text{ in})}$$

$$H_o = -0.017516 \text{ kip/ft}$$

M_o - Moment per length of pile,

$$M_o = \frac{M_x + (V_z H)}{1.57 b}$$

$$M_o = \frac{(0.297 \text{ kipft}) + ((-0.11 \text{ kip}) \times (0 \text{ ft}))}{1.57 \times (48 \text{ in})}$$

$$M_o = 0.047293 \text{ kipft/ft}$$

E - Distance from lateral load to resisting surface,

$$E = \frac{M_o}{H_o}$$

$$E = \frac{(0.047293 \text{ kipft/ft})}{(-0.017516 \text{ kip/ft})}$$

$$E = 2.7 \text{ ft}$$

a - Distance from resting surface to pivot point,

$$a = \frac{(4 M_o L_e) + (3 H_o L_e^2)}{(6 M_o) + (4 H_o L_e)}$$

$$a = \frac{(4 \times (0.047293 \text{ kipft/ft}) \times (7 \text{ ft})) + (3 \times (-0.017516 \text{ kip/ft}) \times (7 \text{ ft})^2)}{(6 \times (0.047293 \text{ kipft/ft})) + (4 \times (-0.017516 \text{ kip/ft}) \times (7 \text{ ft}))}$$

$$a = 5.0362 \text{ ft}$$

V_{max} - Max shear force located at depth a ,

$$V_{max} = (H_o b) \left[1 - \left[3 \left(\frac{4E}{L_e} + 3 \right) \left(\frac{a}{L_e} \right)^2 \right] + \left[4 \left(\frac{3E}{L_e} + 2 \right) \left(\frac{a}{L_e} \right)^3 \right] \right]$$

$$V_{max} = ((-0.017516 \text{ kip/ft}) \times (48 \text{ in})) \times \left[1 - \left[3 \times \left(\frac{4 \times (2.7 \text{ ft})}{(7 \text{ ft})} + 3 \right) \times \left(\frac{(5.0362 \text{ ft})}{(7 \text{ ft})} \right)^2 \right] \right. \\ \left. + \left[4 \times \left(\frac{3 \times (2.7 \text{ ft})}{(7 \text{ ft})} + 2 \right) \times \left(\frac{(5.0362 \text{ ft})}{(7 \text{ ft})} \right)^3 \right] \right]$$

$$V_{max} = 0.094689 \text{ kip}$$

M_{max} - Max bending moment located at depth $a/2$,

$$M_{max} = (H_o \ b \ L_e) \left[\left(\frac{E}{L_e} + \frac{a}{2 L_e} \right) \right. \\ \left. - \left[\left(\frac{4E}{L_e} + 3 \right) \left(\frac{a}{2 L_e} \right)^3 \right] + \left[\left(\frac{3E}{L_e} + 2 \right) \left(\frac{a}{2 L_e} \right)^4 \right] \right]$$

$$M_{max} = ((-0.017516 \text{ kip/ft}) \times (48 \text{ in}) \times (7 \text{ ft})) \times \left[\left(\frac{(2.7 \text{ ft})}{(7 \text{ ft})} + \frac{(5.0362 \text{ ft})}{2 \times (7 \text{ ft})} \right) \right. \\ \left. - \left[\left(\frac{4 \times (2.7 \text{ ft})}{(7 \text{ ft})} + 3 \right) \times \left(\frac{(5.0362 \text{ ft})}{2 \times (7 \text{ ft})} \right)^3 \right] + \left[\left(\frac{3 \times (2.7 \text{ ft})}{(7 \text{ ft})} + 2 \right) \times \left(\frac{(5.0362 \text{ ft})}{2 \times (7 \text{ ft})} \right)^4 \right] \right]$$

$$M_{max} = 0.28781 \text{ kipft}$$

Minimum Reinforcement Check (LRFD)

Parameters:

$f'_{ck} = 2.5 \text{ ksi}$ - Concrete strength,

$f_{yk} = 60 \text{ ksi}$ - Longitudinal reinforcement strength,

$\phi = 0.65$ - Reduction factor for axial strength,

$\alpha = 0.8$ - Alpha factor for axial strength,

$A_g = 2304 \text{ in}^2$ - Gross area of concrete,

Longitudinal reinforcement:

Required reinforcement due to axial load, $A_{st,required}$

$A_{st,required}$

$$A_{st,required} = \text{Min} \left[\frac{\frac{P}{\phi \alpha} - (0.85 f'_{ck} A_g)}{f_{yk} - (0.85 f'_{ck})}, (0.08 A_g) \right]$$

$$A_{st,required} = \text{Min} \left[\frac{\frac{(3.597 \text{ kip})}{(0.65) \times (0.8)} - (0.85 \times (2.5 \text{ ksi}) \times (2304 \text{ in}^2))}{(60 \text{ ksi}) - (0.85 \times (2.5 \text{ ksi}))}, (0.08 \times (2304 \text{ in}^2)) \right]$$

$$A_{st,required} = -84.477 \text{ in}^2$$

A_{min} - Governing minimum reinforcement area,

$$A_{min} = \text{Max} [A_{st,required}, (0.0018 A_g)]$$

$$A_{min} = \text{Max} [(-84.477 \text{ in}^2), (0.0018 \times (2304 \text{ in}^2))]$$

$$A_{min} = 4.1472 \text{ in}^2$$

n_{rebar} - Required number of reinforcement,

$$n_{rebar} = \frac{A_{min}}{A_{rebar}}$$

$$n_{rebar} = \frac{(4.1472 \text{ in}^2)}{(0.3068 \text{ in}^2)}$$

$$n_{rebar} = 14$$

A_{st} - Actual total reinforcement area,

$$A_{st} = n_{rebar} \frac{\pi d_{bar}^2}{4}$$

$$A_{st} = (14) \times \frac{\pi \times (0.625 \text{ in})^2}{4}$$

$$A_{st} = 4.2951 \text{ in}^2$$

Ratio - Capacity

$$\text{Ratio} = \frac{A_{min}}{A_{st}}$$

$$\text{Ratio} = \frac{(4.1472 \text{ in}^2)}{(4.2951 \text{ in}^2)}$$

Table 22.4.2.1

22.4.2.2, 10.6.1.1

<p>25.2.3</p> <p>25.7.2.2</p> <p>25.7.2.1</p>	<p style="text-align: center;">$Ratio = 0.96556$</p> <p>$s_{rebar} = Max[1.5, (1.5 d_{bar})]$</p> <p>$s_{rebar} = Max[1.5, (1.5 \times (0.625 \text{ in}))]$</p> <p>$s_{rebar} = 1.5 \text{ in}$</p> <p>Ties:</p> <p>Since longitudinal reinforcement is \leq No. 10ø: Use #3(0.375 in)</p> <p>$s_{ties} = Min[(16 d_{bar}), (48 d_{ties}), Min(D, b)]$</p> <p>$s_{ties} = Min[(16 \times (0.625 \text{ in})), (48 \times (0.375 \text{ in})), Min((48 \text{ in}), (48 \text{ in}))]$</p> <p>$s_{ties} = 10 \text{ in}$</p> <p>Summary:</p> <p style="text-align: center;">Main reinforcement: 14 - #5 (0.625 in) Ties: #3(0.375 in) - 10 in</p>	<p>Status: PASS Ratio: 0.970</p>
<p>22.4.2.2</p>	<p>Axial Compression Strength (ACI 318-19, LRFD)</p> <p>ϕP_N - Allowable axial compressive strength</p> <p style="text-align: center;">$\phi P_N = \phi 0.80 [(0.85 f'_{ck} [A_g - A_{st}]) + (f_{yk} A_{st})]$</p> <p style="text-align: center;">$\phi P_N = (0.65) \times 0.80 \times [(0.85 \times (2.5 \text{ ksi}) \times [(2304 \text{ in}^2) - (4.2951 \text{ in}^2)]) + ((60 \text{ ksi}) \times (4.2951 \text{ in}^2))]$</p> <p style="text-align: center;">$\phi P_N = 2675.2 \text{ kip}$</p> <p>Ratio - Capacity</p> <p style="text-align: center;">$Ratio = \frac{P}{\phi P_N}$</p> <p style="text-align: center;">$Ratio = \frac{(3.597 \text{ kip})}{(2675.2 \text{ kip})}$</p> <p style="text-align: center;">$Ratio = 0.0013446$</p>	<p>Status: PASS Ratio: 0.000</p>
<p>22.5.2.2</p> <p>22.5.5.1.3</p> <p>22.5.5.1.1</p>	<p>Shear Strength (ACI 318-19, LRFD)</p> <p>Parameters:</p> <p>$b_w = 48 \text{ in}$ - Effective width, d - Effective depth</p> <p style="text-align: center;">$d = 0.80 D$</p> <p style="text-align: center;">$d = 0.80 \times (48 \text{ in})$</p> <p style="text-align: center;">$d = 38.4 \text{ in}$</p> <p>λ_s - size effect modification factor</p> <p style="text-align: center;">$\lambda_s = MIN \left[\sqrt{\frac{2}{1 + \frac{d}{10}}}, 1 \right]$</p> <p style="text-align: center;">$\lambda_s = MIN \left[\sqrt{\frac{2}{1 + \frac{(38.4 \text{ in})}{10}}}, 1 \right]$</p> <p style="text-align: center;">$\lambda_s = 0.64282$</p> <p>The following variables were converted to be consistent with empirical formula $f'_{ck} = 2.5 \text{ ksi} \rightarrow 2500 \text{ psi}$,</p> <p>$V_{c,max}$ - Max shear strength of concrete</p> <p style="text-align: center;">$V_{c,max} = 5 \lambda_s \sqrt{f'_{ck}} b_w d$</p> <p style="text-align: center;">$V_{c,max} = 5 \times (0.64282) \times \sqrt{(2500 \text{ psi})} \times (48 \text{ in}) \times (38.4 \text{ in})$</p>	

$$V_{c,max} = 296.21 \text{ kip}$$

22.5.5.1.1(a) The following variables were converted to be consistent with empirical formula $f'_{ck} = 2.5 \text{ ksi} \rightarrow 2500 \text{ psi}$, $P = 3.597 \text{ kip} \rightarrow 3597 \text{ lbf}$,
 $V_{c,a}$ - Shear strength of concrete (a)

$$V_{c,a} = \left[2 \lambda_s \sqrt{f'_{ck} + \frac{P}{6 A_g}} \right] b_w d$$

$$V_{c,a} = \left[2 \times (0.64282) \times \sqrt{(2500 \text{ psi}) + \frac{(3597 \text{ lbf})}{6 \times (2304 \text{ in}^2)}} \right] \times (48 \text{ in}) \times (38.4 \text{ in})$$

$$V_{c,a} = 118.96 \text{ kip}$$

22.5.5.1.2 The following variables were converted to be consistent with empirical formula $f'_{ck} = 2.5 \text{ ksi} \rightarrow 2500 \text{ psi}$,
 $V_{c,b}$ - Shear strength of concrete (b)

$$V_{c,b} = \left[2 \lambda_s \sqrt{f'_{ck} + (0.05 f'_{ck})} \right] b_w d$$

$$V_{c,b} = \left[2 \times (0.64282) \times \sqrt{(2500 \text{ psi}) + (0.05 \times (2500 \text{ psi}))} \right] \times (48 \text{ in}) \times (38.4 \text{ in})$$

$$V_{c,b} = 348.89 \text{ kip}$$

V_c - Governing shear strength of concrete

$$V_c = \text{Min}[V_{c,max}, V_{c,a}, V_{c,b}]$$

$$V_c = \text{Min}[(296.21 \text{ kip}), (118.96 \text{ kip}), (348.89 \text{ kip})]$$

$$V_c = 118.96 \text{ kip}$$

22.5.5.1.2 The following variables were converted to be consistent with empirical formula $f'_{ck} = 2.5 \text{ ksi} \rightarrow 2500 \text{ psi}$,
 $V_{s,a}$ - Shear strength of steel (a)

$$V_{s,a} = 8 \sqrt{f'_{ck}} b_w d$$

$$V_{s,a} = 8 \times \sqrt{(2500 \text{ psi})} \times (48 \text{ in}) \times (38.4 \text{ in})$$

$$V_{s,a} = 737.28 \text{ kip}$$

A_v - Ties rebar area,

$$A_v = \frac{\pi d_{ties}^2}{4}$$

$$A_v = \frac{\pi \times (0.375 \text{ in})^2}{4}$$

$$A_v = 0.11045 \text{ in}^2$$

22.5.8.5.3 $V_{s,b}$ - Shear strength of steel (b)

$$V_{s,b} = \frac{2 A_v f_{yw} d}{s_{ties}}$$

$$V_{s,b} = \frac{2 \times (0.11045 \text{ in}^2) \times (60 \text{ ksi}) \times (38.4 \text{ in})}{(10 \text{ in})}$$

$$V_{s,b} = 50.894 \text{ kip}$$

V_s - Governing shear strength of steel

$$V_s = \text{MIN}[V_{s,a}, V_{s,b}]$$

$$V_s = \text{MIN}[(737.28 \text{ kip}), (50.894 \text{ kip})]$$

$$V_s = 50.894 \text{ kip}$$

22.5.1.1 ϕV_n - Allowable shear strength

$$\phi V_n = \phi (V_c + V_s)$$

$$\phi V_n = (0.65) \times ((118.96 \text{ kip}) + (50.894 \text{ kip}))$$

$$\phi V_n = 110.41 \text{ kip}$$

Considering x-direction:

V_{max} = 12.19 kip - Maximum shear force in the x-direction,
 Ratio - Capacity

$$\text{Ratio} = \frac{V_{max}}{\phi V_n}$$

$$Ratio = \frac{(12.19 \text{ kip})}{(110.41 \text{ kip})}$$

$$Ratio = 0.11041$$

Status: **PASS**
Ratio: **0.110**

Considering z-direction:

$V_{max} = 0.094689 \text{ kip}$ - Maximum shear force in the z-direction,

Ratio - Capacity

$$Ratio = \frac{V_{max}}{\phi V_n}$$

$$Ratio = \frac{(0.094689 \text{ kip})}{(110.41 \text{ kip})}$$

$$Ratio = 0.00085762$$

Status: **PASS**
Ratio: **0.000**

Flexural Strength (ACI 318-19, LRFD)

S_m - Section modulus

$$S_m = \frac{b D^2}{6}$$

$$S_m = \frac{(48 \text{ in}) \times (48 \text{ in})^2}{6}$$

$$S_m = 18432 \text{ in}^3$$

$\lambda = 1$ - Concrete modification factor (Normal concrete),

Allowable flexural strength:

M_n shall be the lesser of:

$\phi M_{n,1}$

$$\phi M_{n,1} = \phi \times 5 \times \lambda \times \sqrt{f'_c} \times S_m$$

$$\phi M_{n,1} = 0.65 \times 5 \times 1 \times \sqrt{(2.5 \text{ ksi})} \times 18432.001 \text{ in}^3$$

$$\phi M_{n,1} = 249.600 \text{ kipft}$$

14.5.2.1b

$\phi M_{n,2}$

$$\phi M_{n,2} = \phi \times 0.85 \times f'_{ck} \times S_m$$

$$\phi M_{n,2} = (0.65) \times 0.85 \times (2.5 \text{ ksi}) \times (18432 \text{ in}^3)$$

$$\phi M_{n,2} = 2121.6 \text{ kipft}$$

Therefore,

ϕM_n - Allowable flexural strength,

$$\phi M_n = \text{MIN}[\phi M_{n,1}, \phi M_{n,2}]$$

$$\phi M_n = \text{MIN}[(249.6 \text{ kipft}), (2121.6 \text{ kipft})]$$

$$\phi M_n = 249.6 \text{ kipft}$$

Considering x-direction:

$M_{max} = 40.339 \text{ kipft}$ - Maximum moment in the x-direction,

Ratio - Capacity

$$Ratio = \frac{M_{max}}{\phi M_n}$$

$$Ratio = \frac{(40.339 \text{ kipft})}{(249.6 \text{ kipft})}$$

$$Ratio = 0.16162$$

Status: **PASS**
Ratio: **0.160**

Considering z-direction:

$M_{max} = 0.28781 \text{ kipft}$ - Maximum moment in the z-direction,

Ratio - Capacity

$$Ratio = \frac{M_{max}}{\phi M_n}$$

$$\text{Ratio} = \frac{(0.28781 \text{ kipft})}{(249.6 \text{ kipft})}$$

$$\text{Ratio} = 0.0011531$$

Status: **PASS**
Ratio: **0.000**

REFERENCES	CALCULATIONS	RESULTS
------------	--------------	---------

SkyCiv Foundation Design

Pile Foundation

Design Information :

Design code : IBC 2021 (International Building Code)
Unit System : Imperial

Pile Input

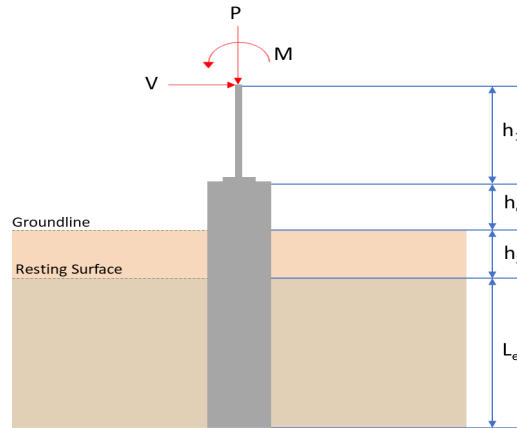

Geometry

Pile shape: rectangular

$b = 48$ in - Pile width

$D = 48$ in - Pile depth

$L = 7$ ft - Total pile length

$h_1 = 0$ ft - Lateral load height from the top of the pile,

$h_2 = 0$ ft - Depth to resisting surface

$h_e = 0$ ft - Length of pile above the ground

Tabulation of Soil Parameters

Layer	Label	Allowable Bearing Pressure (q_a) (psf)	Allowable Lateral Pressure (R) (psf/ft)
1	Sand, silty sand, clayey sand, silty gravel & clayey gravel	2000.000	150.000

Tabulation of Loads

Load Component	ASD	LRFD
P (kip)	2.638	3.597
V_x (kip)	-3.453	-5.755
V_z (kip)	0.071	0.110
M_x (kipft)	0.192	0.297
M_z (kipft)	36.212	60.699

Material Properties

$f'_{ck} = 2.5$ ksi - Concrete strength.

Required depth to resist lateral loads (ASD)

H - Point of application of the lateral load

$$H = h_1 + h_2 + h_e$$

$$H = (0 \text{ ft}) + (0 \text{ ft}) + (0 \text{ ft})$$

$$H = 0 \text{ ft}$$

Considering x-direction:

H_o - Lateral force per length of pile,

$$H_o = \frac{V_x}{1.57 D}$$

$$H_o = \frac{(-3.453 \text{ kip})}{1.57 \times (48 \text{ in})}$$

$$H_o = -0.54984 \text{ kip/ft}$$

M_o - Moment per length of pile,

$$M_o = \frac{M_z + (V_x H)}{1.57 D}$$

$$M_o = \frac{(36.212 \text{ kipft}) + ((-3.453 \text{ kip}) \times (0 \text{ ft}))}{1.57 \times (48 \text{ in})}$$

$$M_o = 5.7662 \text{ kipft/ft}$$

Required depth of embedment in earth:

$$L_x^3 - \left(14.14 \times \frac{H_o \times L_x}{R} \right) - \left(18.85 \times \frac{M_o}{R} \right) = 0$$

Solving the cubic equation:

$L_{e,x} = 6.3224 \text{ ft}$ - Required depth in x-direction,

Considering z-direction:

H_o - Lateral force per length of pile,

$$H_o = \frac{V_z}{1.57 b}$$

$$H_o = \frac{(0.071 \text{ kip})}{1.57 \times (48 \text{ in})}$$

$$H_o = 0.011306 \text{ kip/ft}$$

M_o - Moment per length of pile,

$$M_o = \frac{M_x + (V_z H)}{1.57 b}$$

$$M_o = \frac{(0.192 \text{ kipft}) + ((0.071 \text{ kip}) \times (0 \text{ ft}))}{1.57 \times (48 \text{ in})}$$

$$M_o = 0.030573 \text{ kipft/ft}$$

Required depth of embedment in earth:

$$L_z^3 - \left(14.14 \times \frac{H_o \times L_z}{R} \right) - \left(18.85 \times \frac{M_o}{R} \right) = 0$$

Solving the cubic equation:

$L_{e,z} = 1.5144 \text{ ft}$ - Required depth in z-direction,

Minimum embedded depth required:

$L_{e,req}$ - Depth of pile required,

$$L_{e,req} = \text{MAX}[L_{e,x}, L_{e,z}]$$

$$L_{e,req} = \text{MAX}[(6.3224 \text{ ft}), (1.5144 \text{ ft})]$$

$$L_{e,req} = 6.322 \text{ ft}$$

L_e - Actual embedded length of pile,

$$L_e = L - h_e - h_2$$

$$L_e = (7 \text{ ft}) - (0 \text{ ft}) - (0 \text{ ft})$$

$$L_e = 7 \text{ ft}$$

Ratio - Embedded depth

$$\text{Ratio} = \frac{L_{e,req}}{L_e}$$

$$\text{Ratio} = \frac{(6.322 \text{ ft})}{(7 \text{ ft})}$$

$$\text{Ratio} = 0.90314$$

Status: **PASS**
Ratio: **0.900**

End-bearing Capacity (ASD)

A - Pile cross-section area

$$A = b D$$

$$A = (48 \text{ in}) \times (48 \text{ in})$$

$$A = 16 \text{ ft}^2$$

q - End-bearing pressure

$$q = \frac{P_v}{A}$$

$$q = \frac{(2.638 \text{ kip})}{(16 \text{ ft}^2)}$$

$$q = 0.16487 \text{ kip/ft}^2$$

Check bearing capacity ratio:

Ratio - Capacity

$$\text{Ratio} = \frac{q}{q_a}$$

$$\text{Ratio} = \frac{(0.16487 \text{ kip/ft}^2)}{(2000 \text{ psf})}$$

$$\text{Ratio} = 0.082437$$

Status: **PASS**
Ratio: **0.080**

Czerniak

Lateral Soil Pressure (ASD):

L/D - Length to least lateral dimension ratio,

$$L/D = \frac{L}{D}$$

$$L/D = \frac{(7 \text{ ft})}{(48 \text{ in})}$$

$$L/D = 1.75$$

Since $L/D \leq 10$,

Pile is short.

Considering x-direction:

$H_o = -0.54984 \text{ kip/ft}$ - Lateral force per length of pile,

$M_o = 5.7662 \text{ kipft/ft}$ - Overturning moment per length of pile,

a - Distance from resting surface to pivot point,

$$a = \frac{(4 M_o L_e) + (3 H_o L_e^2)}{(6 M_o) + (4 H_o L_e)}$$

$$a = \frac{(4 \times (5.7662 \text{ kipft/ft}) \times (7 \text{ ft})) + (3 \times (-0.54984 \text{ kip/ft}) \times (7 \text{ ft})^2)}{(6 \times (5.7662 \text{ kipft/ft})) + (4 \times (-0.54984 \text{ kip/ft}) \times (7 \text{ ft}))}$$

$$a = 4.8463 \text{ ft}$$

p - Earth pressure against the pile at distance $a/2$ from resting surface,

$$p = \frac{0.75 [(4 M_o) + (3 H_o L_e)]^2}{L_e^2 [(3 M_o) + (2 H_o L_e)]}$$

$$p = \frac{0.75 \times [(4 \times (5.7662 \text{ kipft/ft})) + (3 \times (-0.54984 \text{ kip/ft}) \times (7 \text{ ft}))]^2}{(7 \text{ ft})^2 \times [(3 \times (5.7662 \text{ kipft/ft})) + (2 \times (-0.54984 \text{ kip/ft}) \times (7 \text{ ft}))]}$$

$$p = 0.21151 \text{ kip/ft}^2$$

s - Earth pressure against the pile at distance L_e ,

$$s = \frac{6 [(2 M_o) + (H_o L_e)]}{L_e^2}$$

$$s = \frac{6 \times [(2 \times (5.7662 \text{ kipft/ft})) + ((-0.54984 \text{ kip/ft}) \times (7 \text{ ft}))]}{(7 \text{ ft})^2}$$

$$s = 0.94085 \text{ kip/ft}^2$$

Check lateral soil pressure capacity:

p_a - Allowable lateral soil pressure at depth $a/2$,

$$p_a = R \frac{a}{2}$$

$$p_a = (150 \text{ psf/ft}) \times \frac{(4.8463 \text{ ft})}{2}$$

$$p_a = 0.36347 \text{ kip/ft}^2$$

Ratio - Lateral soil capacity

$$Ratio = \frac{p}{p_a}$$

$$Ratio = \frac{(0.21151 \text{ kip/ft}^2)}{(0.36347 \text{ kip/ft}^2)}$$

$$Ratio = 0.58191$$

p_s - Allowable lateral soil pressure at depth L_e ,

$$p_s = R L_e$$

$$p_s = (150 \text{ psf/ft}) \times (7 \text{ ft})$$

$$p_s = 1.05 \text{ kip/ft}^2$$

Ratio - Lateral soil capacity

$$Ratio = \frac{s}{p_s}$$

$$Ratio = \frac{(0.94085 \text{ kip/ft}^2)}{(1.05 \text{ kip/ft}^2)}$$

$$Ratio = 0.89605$$

Status: **PASS**
Ratio: **0.580**

Status: **PASS**
Ratio: **0.900**

Considering z-direction:

$H_o = 0.011306 \text{ kip/ft}$ - Lateral force per length of pile,

$M_o = 0.030573 \text{ kipft/ft}$ - Overturning moment per length of pile,

a - Distance from resting surface to pivot point,

$$a = \frac{(4 M_o L_e) + (3 H_o L_e^2)}{(6 M_o) + (4 H_o L_e)}$$

$$a = \frac{(4 \times (0.030573 \text{ kipft/ft}) \times (7 \text{ ft})) + (3 \times (0.011306 \text{ kip/ft}) \times (7 \text{ ft})^2)}{(6 \times (0.030573 \text{ kipft/ft})) + (4 \times (0.011306 \text{ kip/ft}) \times (7 \text{ ft}))}$$

$$a = 5.036 \text{ ft}$$

p - Earth pressure against the pile at distance $a/2$ from resting surface,

$$p = \frac{0.75 [(4 M_o) + (3 H_o L_e)]^2}{L_e^2 [(3 M_o) + (2 H_o L_e)]}$$

$$p = \frac{0.75 \times [(4 \times (0.030573 \text{ kipft/ft})) + (3 \times (0.011306 \text{ kip/ft}) \times (7 \text{ ft}))]^2}{(7 \text{ ft})^2 \times [(3 \times (0.030573 \text{ kipft/ft})) + (2 \times (0.011306 \text{ kip/ft}) \times (7 \text{ ft}))]}$$

$$p = 0.0079221 \text{ kip/ft}^2$$

s - Earth pressure against the pile at distance L_e ,

$$s = \frac{6 [(2 M_o) + (H_o L_e)]}{L_e^2}$$

$$s = \frac{6 \times [(2 \times (0.030573 \text{ kipft/ft})) + ((0.011306 \text{ kip/ft}) \times (7 \text{ ft}))]}{(7 \text{ ft})^2}$$

$$s = 0.017178 \text{ kip/ft}^2$$

Check lateral soil pressure capacity:

p_a - Allowable lateral soil pressure at depth $a/2$,

$$p_a = R \frac{a}{2}$$

$$p_a = (150 \text{ psf/ft}) \times \frac{(5.036 \text{ ft})}{2}$$

$$p_a = 0.3777 \text{ kip/ft}^2$$

Ratio - Lateral soil capacity

$$Ratio = \frac{p}{p_a}$$

$$Ratio = \frac{(0.0079221 \text{ kip/ft}^2)}{(0.3777 \text{ kip/ft}^2)}$$

$$Ratio = 0.020975$$

p_s - Allowable lateral soil pressure at depth L_e ,

$$p_s = R L_e$$

$$p_s = (150 \text{ psf/ft}) \times (7 \text{ ft})$$

$$p_s = 1.05 \text{ kip/ft}^2$$

Ratio - Lateral soil capacity

$$Ratio = \frac{s}{p_s}$$

$$Ratio = \frac{(0.017178 \text{ kip/ft}^2)}{(1.05 \text{ kip/ft}^2)}$$

$$Ratio = 0.01636$$

Status: **PASS**
Ratio: **0.020**

Status: **PASS**
Ratio: **0.020**

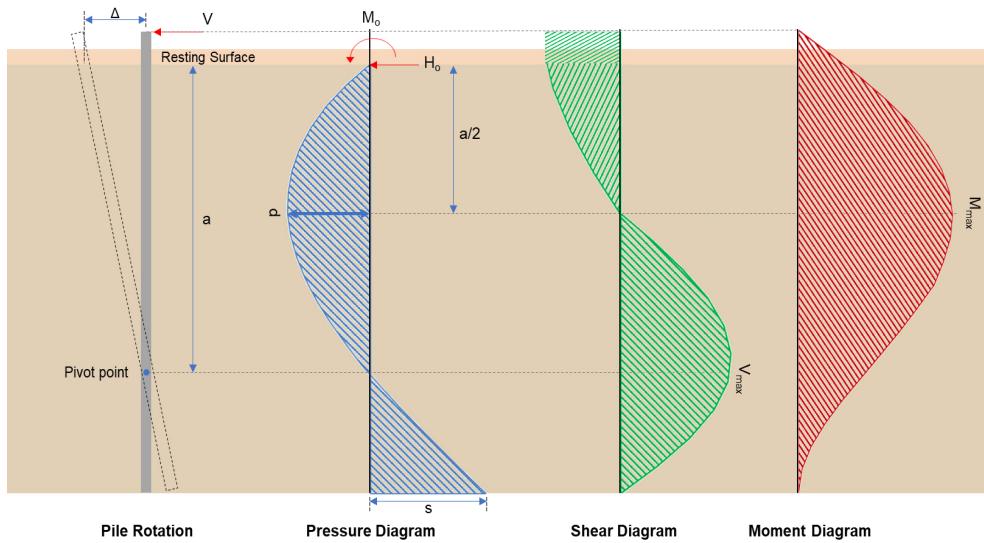

Shear force and Bending moment (x-direction, LRFD)

H_o - Lateral force per length of pile,

$$H_o = \frac{V_x}{1.57 D}$$

$$H_o = \frac{(-5.755 \text{ kip})}{1.57 \times (48 \text{ in})}$$

$$H_o = -0.9164 \text{ kip/ft}$$

M_o - Moment per length of pile,

$$M_o = \frac{M_z + (V_x H)}{1.57 D}$$

$$M_o = \frac{(60.699 \text{ kipft}) + ((-5.755 \text{ kip}) \times (0 \text{ ft}))}{1.57 \times (48 \text{ in})}$$

$$M_o = 9.6654 \text{ kipft/ft}$$

E - Distance from lateral load to resisting surface,

$$E = \frac{M_o}{H_o}$$

$$E = \frac{(9.6654 \text{ kipft/ft})}{(-0.9164 \text{ kip/ft})}$$

$$E = 10.547 \text{ ft}$$

a - Distance from resting surface to pivot point,

$$a = \frac{(4 M_o L_e) + (3 H_o L_e^2)}{(6 M_o) + (4 H_o L_e)}$$

$$a = \frac{(4 \times (9.6654 \text{ kipft/ft}) \times (7 \text{ ft})) + (3 \times (-0.9164 \text{ kip/ft}) \times (7 \text{ ft})^2)}{6 \times (9.6654 \text{ kipft/ft}) + 4 \times (-0.9164 \text{ kip/ft}) \times (7 \text{ ft})}$$

$$a = \frac{(6 \times (9.6654 \text{ kipft/ft})) + (4 \times (-0.9164 \text{ kip/ft}) \times (7 \text{ ft}))}{}$$

$$a = 4.8456 \text{ ft}$$

V_{max} - Max shear force located at depth a,

$$V_{max} = (H_o D) \left[1 - \left[3 \left(\frac{4E}{L_e} + 3 \right) \left(\frac{a}{L_e} \right)^2 \right] + \left[4 \left(\frac{3E}{L_e} + 2 \right) \left(\frac{a}{L_e} \right)^3 \right] \right]$$

$$V_{max} = ((-0.9164 \text{ kip/ft}) \times (48 \text{ in})) \times \left[1 - \left[3 \times \left(\frac{4 \times (10.547 \text{ ft})}{(7 \text{ ft})} + 3 \right) \times \left(\frac{(4.8456 \text{ ft})}{(7 \text{ ft})} \right)^2 \right] + \left[4 \times \left(\frac{3 \times (10.547 \text{ ft})}{(7 \text{ ft})} + 2 \right) \times \left(\frac{(4.8456 \text{ ft})}{(7 \text{ ft})} \right)^3 \right] \right]$$

$$V_{max} = 12.19 \text{ kip}$$

M_{max} - Max bending moment located at depth a/2,

$$M_{max} = (H_o D L_e) \left[\left(\frac{E}{L_e} + \frac{a}{2 L_e} \right) - \left[\left(\frac{4E}{L_e} + 3 \right) \left(\frac{a}{2 L_e} \right)^3 \right] + \left[\left(\frac{3E}{L_e} + 2 \right) \left(\frac{a}{2 L_e} \right)^4 \right] \right]$$

$$M_{max} = ((-0.9164 \text{ kip/ft}) \times (48 \text{ in}) \times (7 \text{ ft})) \times \left[\left(\frac{(10.547 \text{ ft})}{(7 \text{ ft})} + \frac{(4.8456 \text{ ft})}{2 \times (7 \text{ ft})} \right) - \left[\left(\frac{4 \times (10.547 \text{ ft})}{(7 \text{ ft})} + 3 \right) \times \left(\frac{(4.8456 \text{ ft})}{2 \times (7 \text{ ft})} \right)^3 \right] + \left[\left(\frac{3 \times (10.547 \text{ ft})}{(7 \text{ ft})} + 2 \right) \times \left(\frac{(4.8456 \text{ ft})}{2 \times (7 \text{ ft})} \right)^4 \right] \right]$$

$$M_{max} = 40.34 \text{ kipft}$$

Shear force and Bending moment (z-direction, LRFD)

H_o - Lateral force per length of pile,

$$H_o = \frac{V_z}{1.57 b}$$

$$H_o = \frac{(0.11 \text{ kip})}{1.57 \times (48 \text{ in})}$$

$$H_o = 0.017516 \text{ kip/ft}$$

M_o - Moment per length of pile,

$$M_o = \frac{M_x + (V_z H)}{1.57 b}$$

$$M_o = \frac{(0.297 \text{ kipft}) + ((0.11 \text{ kip}) \times (0 \text{ ft}))}{1.57 \times (48 \text{ in})}$$

$$M_o = 0.047293 \text{ kipft/ft}$$

E - Distance from lateral load to resisting surface,

$$E = \frac{M_o}{H_o}$$

$$E = \frac{(0.047293 \text{ kipft/ft})}{(0.017516 \text{ kip/ft})}$$

$$E = 2.7 \text{ ft}$$

a - Distance from resting surface to pivot point,

$$a = \frac{(4 M_o L_e) + (3 H_o L_e^2)}{(6 M_o) + (4 H_o L_e)}$$

$$a = \frac{(4 \times (0.047293 \text{ kipft/ft}) \times (7 \text{ ft})) + (3 \times (0.017516 \text{ kip/ft}) \times (7 \text{ ft})^2)}{(6 \times (0.047293 \text{ kipft/ft})) + (4 \times (0.017516 \text{ kip/ft}) \times (7 \text{ ft}))}$$

$$a = 5.0362 \text{ ft}$$

V_{max} - Max shear force located at depth a,

$$V_{max} = (H_o b) \left[1 - \left[3 \left(\frac{4E}{L_e} + 3 \right) \left(\frac{a}{L_e} \right)^2 \right] + \left[4 \left(\frac{3E}{L_e} + 2 \right) \left(\frac{a}{L_e} \right)^3 \right] \right]$$

$$V_{max} = ((0.017516 \text{ kip/ft}) \times (48 \text{ in})) \times \left[1 - \left[3 \times \left(\frac{4 \times (2.7 \text{ ft})}{(7 \text{ ft})} + 3 \right) \times \left(\frac{(5.0362 \text{ ft})}{(7 \text{ ft})} \right)^2 \right] \right. \\ \left. + \left[4 \times \left(\frac{3 \times (2.7 \text{ ft})}{(7 \text{ ft})} + 2 \right) \times \left(\frac{(5.0362 \text{ ft})}{(7 \text{ ft})} \right)^3 \right] \right]$$

$$V_{max} = 0.094689 \text{ kip}$$

M_{max} - Max bending moment located at depth $a/2$,

$$M_{max} = (H_o \ b \ L_e) \left[\left(\frac{E}{L_e} + \frac{a}{2 L_e} \right) \right. \\ \left. - \left[\left(\frac{4E}{L_e} + 3 \right) \left(\frac{a}{2 L_e} \right)^3 \right] + \left[\left(\frac{3E}{L_e} + 2 \right) \left(\frac{a}{2 L_e} \right)^4 \right] \right]$$

$$M_{max} = ((0.017516 \text{ kip/ft}) \times (48 \text{ in}) \times (7 \text{ ft})) \times \left[\left(\frac{(2.7 \text{ ft})}{(7 \text{ ft})} + \frac{(5.0362 \text{ ft})}{2 \times (7 \text{ ft})} \right) \right. \\ \left. - \left[\left(\frac{4 \times (2.7 \text{ ft})}{(7 \text{ ft})} + 3 \right) \times \left(\frac{(5.0362 \text{ ft})}{2 \times (7 \text{ ft})} \right)^3 \right] + \left[\left(\frac{3 \times (2.7 \text{ ft})}{(7 \text{ ft})} + 2 \right) \times \left(\frac{(5.0362 \text{ ft})}{2 \times (7 \text{ ft})} \right)^4 \right] \right]$$

$$M_{max} = 0.28781 \text{ kipft}$$

Minimum Reinforcement Check (LRFD)

Parameters:

$f'_{ck} = 2.5 \text{ ksi}$ - Concrete strength,

$f_{yk} = 60 \text{ ksi}$ - Longitudinal reinforcement strength,

$\phi = 0.65$ - Reduction factor for axial strength,

$\alpha = 0.8$ - Alpha factor for axial strength,

$A_g = 2304 \text{ in}^2$ - Gross area of concrete,

Longitudinal reinforcement:

Required reinforcement due to axial load, $A_{st,required}$

$A_{st,required}$

$$A_{st,required} = \text{Min} \left[\frac{\frac{P}{\phi \alpha} - (0.85 f'_{ck} A_g)}{f_{yk} - (0.85 f'_{ck})}, (0.08 A_g) \right]$$

$$A_{st,required} = \text{Min} \left[\frac{\frac{(3.597 \text{ kip})}{(0.65) \times (0.8)} - (0.85 \times (2.5 \text{ ksi}) \times (2304 \text{ in}^2))}{(60 \text{ ksi}) - (0.85 \times (2.5 \text{ ksi}))}, (0.08 \times (2304 \text{ in}^2)) \right]$$

$$A_{st,required} = -84.477 \text{ in}^2$$

A_{min} - Governing minimum reinforcement area,

$$A_{min} = \text{Max} [A_{st,required}, (0.0018 A_g)]$$

$$A_{min} = \text{Max} [(-84.477 \text{ in}^2), (0.0018 \times (2304 \text{ in}^2))]$$

$$A_{min} = 4.1472 \text{ in}^2$$

n_{rebar} - Required number of reinforcement,

$$n_{rebar} = \frac{A_{min}}{A_{rebar}}$$

$$n_{rebar} = \frac{(4.1472 \text{ in}^2)}{(0.3068 \text{ in}^2)}$$

$$n_{rebar} = 14$$

A_{st} - Actual total reinforcement area,

$$A_{st} = n_{rebar} \frac{\pi d_{bar}^2}{4}$$

$$A_{st} = (14) \times \frac{\pi \times (0.625 \text{ in})^2}{4}$$

$$A_{st} = 4.2951 \text{ in}^2$$

Ratio - Capacity

$$\text{Ratio} = \frac{A_{min}}{A_{st}}$$

$$\text{Ratio} = \frac{(4.1472 \text{ in}^2)}{(4.2951 \text{ in}^2)}$$

Table 22.4.2.1

22.4.2.2, 10.6.1.1

<p>25.2.3</p> <p>25.7.2.2</p> <p>25.7.2.1</p>	<p style="text-align: center;">$Ratio = 0.96556$</p> <p>$s_{rebar} = Max[1.5, (1.5 d_{bar})]$</p> <p>$s_{rebar} = Max[1.5, (1.5 \times (0.625 \text{ in}))]$</p> <p>$s_{rebar} = 1.5 \text{ in}$</p> <p>Ties:</p> <p>Since longitudinal reinforcement is \leq No. 10: Use #3(0.375 in)</p> <p>$s_{ties} = Min[(16 d_{bar}), (48 d_{ties}), Min(D, b)]$</p> <p>$s_{ties} = Min[(16 \times (0.625 \text{ in})), (48 \times (0.375 \text{ in})), Min((48 \text{ in}), (48 \text{ in}))]$</p> <p>$s_{ties} = 10 \text{ in}$</p> <p>Summary:</p> <p style="text-align: center;">Main reinforcement: 14 - #5 (0.625 in) Ties: #3(0.375 in) - 10 in</p>	<p>Status: PASS Ratio: 0.970</p>
<p>22.4.2.2</p>	<p>Axial Compression Strength (ACI 318-19, LRFD)</p> <p>ϕP_N - Allowable axial compressive strength</p> <p style="text-align: center;">$\phi P_N = \phi 0.80 [(0.85 f'_{ck} [A_g - A_{st}]) + (f_y A_{st})]$</p> <p style="text-align: center;">$\phi P_N = (0.65) \times 0.80 \times [(0.85 \times (2.5 \text{ ksi}) \times [(2304 \text{ in}^2) - (4.2951 \text{ in}^2)]) + ((60 \text{ ksi}) \times (4.2951 \text{ in}^2))]$</p> <p style="text-align: center;">$\phi P_N = 2675.2 \text{ kip}$</p> <p>Ratio - Capacity</p> <p style="text-align: center;">$Ratio = \frac{P}{\phi P_N}$</p> <p style="text-align: center;">$Ratio = \frac{(3.597 \text{ kip})}{(2675.2 \text{ kip})}$</p> <p style="text-align: center;">$Ratio = 0.0013446$</p>	<p>Status: PASS Ratio: 0.000</p>
<p>22.5.2.2</p> <p>22.5.5.1.3</p> <p>22.5.5.1.1</p>	<p>Shear Strength (ACI 318-19, LRFD)</p> <p>Parameters:</p> <p>$b_w = 48 \text{ in}$ - Effective width, d - Effective depth</p> <p style="text-align: center;">$d = 0.80 D$</p> <p style="text-align: center;">$d = 0.80 \times (48 \text{ in})$</p> <p style="text-align: center;">$d = 38.4 \text{ in}$</p> <p>λ_s - size effect modification factor</p> <p style="text-align: center;">$\lambda_s = MIN \left[\sqrt{\frac{2}{1 + \frac{d}{10}}}, 1 \right]$</p> <p style="text-align: center;">$\lambda_s = MIN \left[\sqrt{\frac{2}{1 + \frac{(38.4 \text{ in})}{10}}}, 1 \right]$</p> <p style="text-align: center;">$\lambda_s = 0.64282$</p> <p>The following variables were converted to be consistent with empirical formula $f'_{ck} = 2.5 \text{ ksi} \rightarrow 2500 \text{ psi}$,</p> <p>$V_{c,max}$ - Max shear strength of concrete</p> <p style="text-align: center;">$V_{c,max} = 5 \lambda_s \sqrt{f'_{ck}} b_w d$</p> <p style="text-align: center;">$V_{c,max} = 5 \times (0.64282) \times \sqrt{(2500 \text{ psi})} \times (48 \text{ in}) \times (38.4 \text{ in})$</p>	

$$V_{c,max} = 296.21 \text{ kip}$$

22.5.5.1.1(a) The following variables were converted to be consistent with empirical formula $f'_{ck} = 2.5 \text{ ksi} \rightarrow 2500 \text{ psi}$, $P = 3.597 \text{ kip} \rightarrow 3597 \text{ lbf}$,
 $V_{c,a}$ - Shear strength of concrete (a)

$$V_{c,a} = \left[2 \lambda_s \sqrt{f'_{ck} + \frac{P}{6 A_g}} \right] b_w d$$

$$V_{c,a} = \left[2 \times (0.64282) \times \sqrt{(2500 \text{ psi}) + \frac{(3597 \text{ lbf})}{6 \times (2304 \text{ in}^2)}} \right] \times (48 \text{ in}) \times (38.4 \text{ in})$$

$$V_{c,a} = 118.96 \text{ kip}$$

22.5.5.1.2 The following variables were converted to be consistent with empirical formula $f'_{ck} = 2.5 \text{ ksi} \rightarrow 2500 \text{ psi}$,
 $V_{c,b}$ - Shear strength of concrete (b)

$$V_{c,b} = \left[2 \lambda_s \sqrt{f'_{ck} + (0.05 f'_{ck})} \right] b_w d$$

$$V_{c,b} = \left[2 \times (0.64282) \times \sqrt{(2500 \text{ psi}) + (0.05 \times (2500 \text{ psi}))} \right] \times (48 \text{ in}) \times (38.4 \text{ in})$$

$$V_{c,b} = 348.89 \text{ kip}$$

V_c - Governing shear strength of concrete

$$V_c = \text{Min} [V_{c,max}, V_{c,a}, V_{c,b}]$$

$$V_c = \text{Min} [(296.21 \text{ kip}), (118.96 \text{ kip}), (348.89 \text{ kip})]$$

$$V_c = 118.96 \text{ kip}$$

22.5.5.1.2 The following variables were converted to be consistent with empirical formula $f'_{ck} = 2.5 \text{ ksi} \rightarrow 2500 \text{ psi}$,
 $V_{s,a}$ - Shear strength of steel (a)

$$V_{s,a} = 8 \sqrt{f'_{ck}} b_w d$$

$$V_{s,a} = 8 \times \sqrt{(2500 \text{ psi})} \times (48 \text{ in}) \times (38.4 \text{ in})$$

$$V_{s,a} = 737.28 \text{ kip}$$

A_v - Ties rebar area,

$$A_v = \frac{\pi d_{ties}^2}{4}$$

$$A_v = \frac{\pi \times (0.375 \text{ in})^2}{4}$$

$$A_v = 0.11045 \text{ in}^2$$

22.5.8.5.3 $V_{s,b}$ - Shear strength of steel (b)

$$V_{s,b} = \frac{2 A_v f_{yw} d}{s_{ties}}$$

$$V_{s,b} = \frac{2 \times (0.11045 \text{ in}^2) \times (60 \text{ ksi}) \times (38.4 \text{ in})}{(10 \text{ in})}$$

$$V_{s,b} = 50.894 \text{ kip}$$

V_s - Governing shear strength of steel

$$V_s = \text{MIN} [V_{s,a}, V_{s,b}]$$

$$V_s = \text{MIN} [(737.28 \text{ kip}), (50.894 \text{ kip})]$$

$$V_s = 50.894 \text{ kip}$$

22.5.1.1 ϕV_n - Allowable shear strength

$$\phi V_n = \phi (V_c + V_s)$$

$$\phi V_n = (0.65) \times ((118.96 \text{ kip}) + (50.894 \text{ kip}))$$

$$\phi V_n = 110.41 \text{ kip}$$

Considering x-direction:

V_{max} = 12.19 kip - Maximum shear force in the x-direction,

Ratio - Capacity

$$\text{Ratio} = \frac{V_{max}}{\phi V_n}$$

$$Ratio = \frac{(12.19 \text{ kip})}{(110.41 \text{ kip})}$$

$$Ratio = 0.11041$$

Status: **PASS**
Ratio: **0.110**

Considering z-direction:

$V_{max} = 0.094689 \text{ kip}$ - Maximum shear force in the z-direction,

Ratio - Capacity

$$Ratio = \frac{V_{max}}{\phi V_n}$$

$$Ratio = \frac{(0.094689 \text{ kip})}{(110.41 \text{ kip})}$$

$$Ratio = 0.00085762$$

Status: **PASS**
Ratio: **0.000**

Flexural Strength (ACI 318-19, LRFD)

S_m - Section modulus

$$S_m = \frac{b D^2}{6}$$

$$S_m = \frac{(48 \text{ in}) \times (48 \text{ in})^2}{6}$$

$$S_m = 18432 \text{ in}^3$$

$\lambda = 1$ - Concrete modification factor (Normal concrete),

Allowable flexural strength:

M_n shall be the lesser of:

$\phi M_{n,1}$

$$\phi M_{n,1} = \phi \times 5 \times \lambda \times \sqrt{f'_c} \times S_m$$

$$\phi M_{n,1} = 0.65 \times 5 \times 1 \times \sqrt{(2.5 \text{ ksi})} \times 18432.001 \text{ in}^3$$

$$\phi M_{n,1} = 249.600 \text{ kipft}$$

14.5.2.1b

$\phi M_{n,2}$

$$\phi M_{n,2} = \phi \times 0.85 \times f'_{ck} \times S_m$$

$$\phi M_{n,2} = (0.65) \times 0.85 \times (2.5 \text{ ksi}) \times (18432 \text{ in}^3)$$

$$\phi M_{n,2} = 2121.6 \text{ kipft}$$

Therefore,

ϕM_n - Allowable flexural strength,

$$\phi M_n = \text{MIN}[\phi M_{n,1}, \phi M_{n,2}]$$

$$\phi M_n = \text{MIN}[(249.6 \text{ kipft}), (2121.6 \text{ kipft})]$$

$$\phi M_n = 249.6 \text{ kipft}$$

Considering x-direction:

$M_{max} = 40.34 \text{ kipft}$ - Maximum moment in the x-direction,

Ratio - Capacity

$$Ratio = \frac{M_{max}}{\phi M_n}$$

$$Ratio = \frac{(40.34 \text{ kipft})}{(249.6 \text{ kipft})}$$

$$Ratio = 0.16162$$

Status: **PASS**
Ratio: **0.160**

Considering z-direction:

$M_{max} = 0.28781 \text{ kipft}$ - Maximum moment in the z-direction,

Ratio - Capacity

$$Ratio = \frac{M_{max}}{\phi M_n}$$

$$\text{Ratio} = \frac{(0.28781 \text{ kipft})}{(249.6 \text{ kipft})}$$

$$\text{Ratio} = 0.0011531$$

Status: **PASS**
Ratio: **0.000**