

# Your Project Calculations



Project Name: MTSOLAR\_ELKIALHKEA3E

S3D Model Link:

[https://platform.skyciv.com/structural?preload\\_name=MTSOLAR\\_ELKIALHKEA3E&preload\\_path=Shared%20Enterprise%20Folder/MT\\_Solar\\_Projects/7\\_2023](https://platform.skyciv.com/structural?preload_name=MTSOLAR_ELKIALHKEA3E&preload_path=Shared%20Enterprise%20Folder/MT_Solar_Projects/7_2023)

Public Model Link:

[https://platform.skyciv.com/structural-viewer?project\\_id=KihZzL0AI7syS7rMQSk0vWxmMYzL6T1YiDntEeZObo9XiWRCEmW4uh3mtuxL0oe](https://platform.skyciv.com/structural-viewer?project_id=KihZzL0AI7syS7rMQSk0vWxmMYzL6T1YiDntEeZObo9XiWRCEmW4uh3mtuxL0oe)

## Array Specification

Product:	Beam
Unique ID:	1P-0-8TOP-HD-84-L-4Hx3W-2EG5
Duty Classification:	HD
Module Width:	44.60 in
Module Length:	89.00in
Number of Rows:	4
Number of Columns:	3
Total Number of Modules:	12
Desired Tilt Angle:	45
Front Edge Clearance:	5
Total Array Height at Tilt:	15.57 ft
Total Frame Length:	21.50 ft
Frame Weight:	940 lbs
Array Dimensions N/S:	15.03 ft
Array Dimensions E/W:	22.50 ft
Rail Length:	180.40 in
Rail Spacing:	3.75 ft
Rail Check:	PASS (57% utilized)

## Support Specifications

Pole Size:	8in Pipe Sch 40
Pole Length above Grade:	10.32 ft
Number of Poles:	1
Pole Spacing:	0

## Foundation Specifications

Foundation Type:	Square
Foundation Dimensions:	48 x 48 in
Foundation Depth (below grade):	Pile 1: 7.00 ft
Foundation Volume:	4.148 y <sup>3</sup>
Foundation Result:	PASSED
Mount Twist:	0.000010 kip

## Site Info

Risk Category:	I
Exposure:	B
Soil Classification:	sand
Site Location:	Hopkinton, NH 03229, USA
Wind Speed:	100 mph
Snow Load:	40 psf
Design Uplift Pressure:	Multiple pressures
Design Downforce Pressure:	Multiple pressures
Design Snow Pressure:	0.010996 ksf

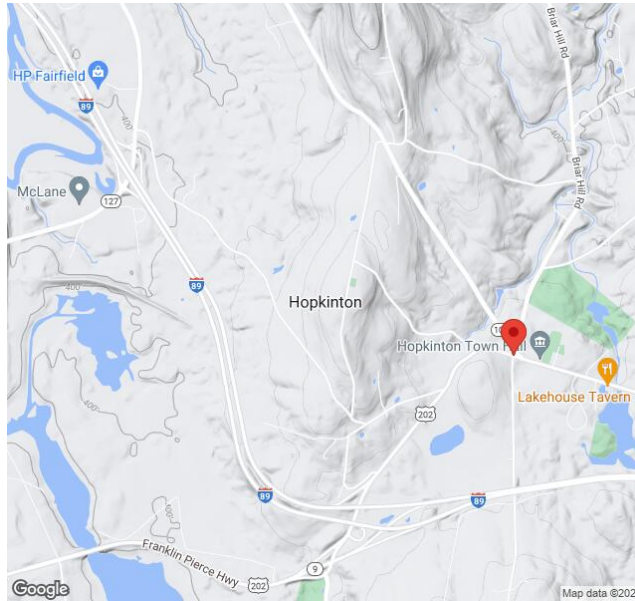

### Design Disclaimer

This software should be used for preliminary designs and should not be used as a final design unless reviewed, verified and designed by a qualified structural engineer.

### AutoDesigner Input

```
{
  "product_type": "Beam",
  "project_id": "MTSOLAR_ELKIALHKEA3E",
  "site_address": "Hopkinton, NH 03229, USA",
  "module_width": 44.6,
  "module_length": 89,
  "number_rows": 4,
  "number_columns": 3,
  "pole_mount_section": "4_40",
  "core_pipe_width": 65,
  "core_pipe_section": "2_40",
  "adjuster_section": "2_40",
  "core_beam_height": 65,
  "core_beam_section": "HSS3x2x1/8",
  "main_pipe_section": "2_12GA",
  "pole_spacing": 15,
  "tilt_angle": 45,
  "ground_clearance": 5,
  "risk_category": "I",
  "exposure_category": "B",
  "frame_duty_override": "auto",
  "pole_override": "8_40",
  "soil_type": "sand",
  "customer_foundation_override": "48_Square",
  "foundation_type": "Square",
  "foundation_size": 48,
  "isolated_foundation_thickness": 18,
  "check_rails": true,
  "wind_speed_override": 100,
  "snow_load_override": 40,
  "direct_snow_load": false,
  "add_angle_brace": false
}
```

### Design Notes:

- AISC Deflection checks are set to L/1 due to structure design intent

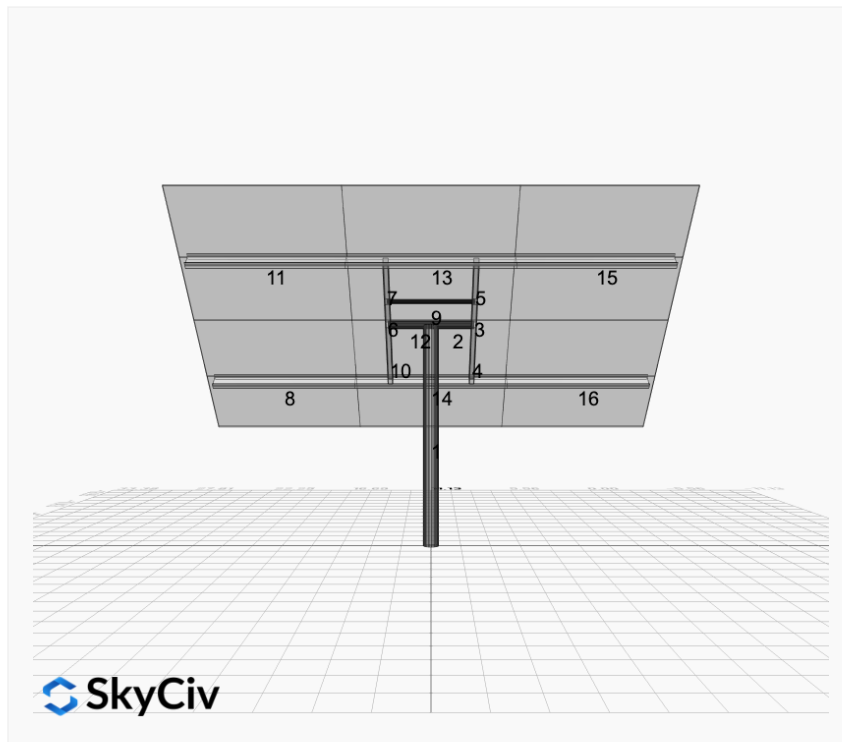

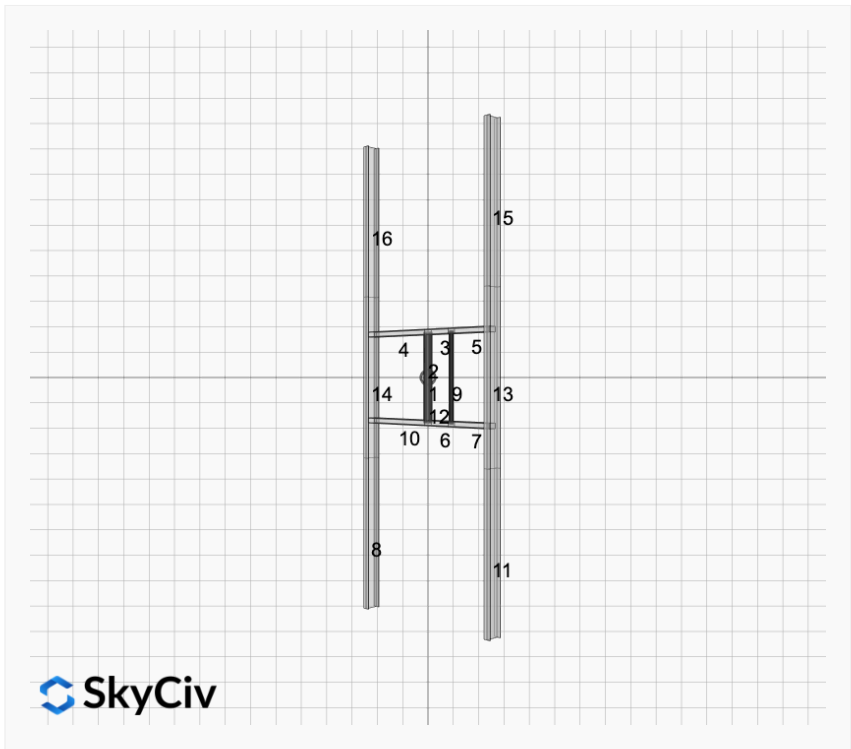
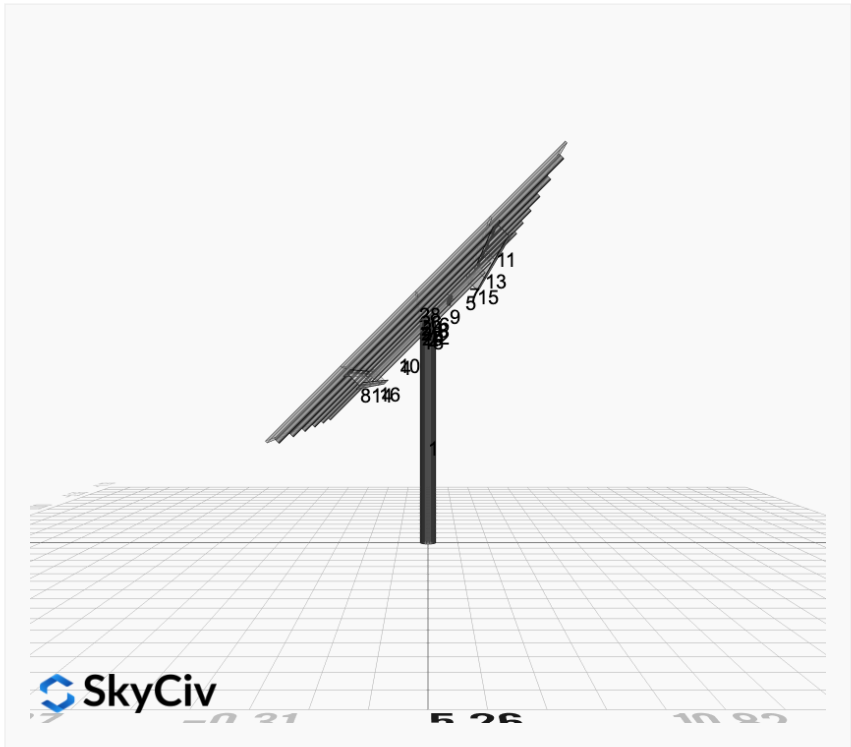

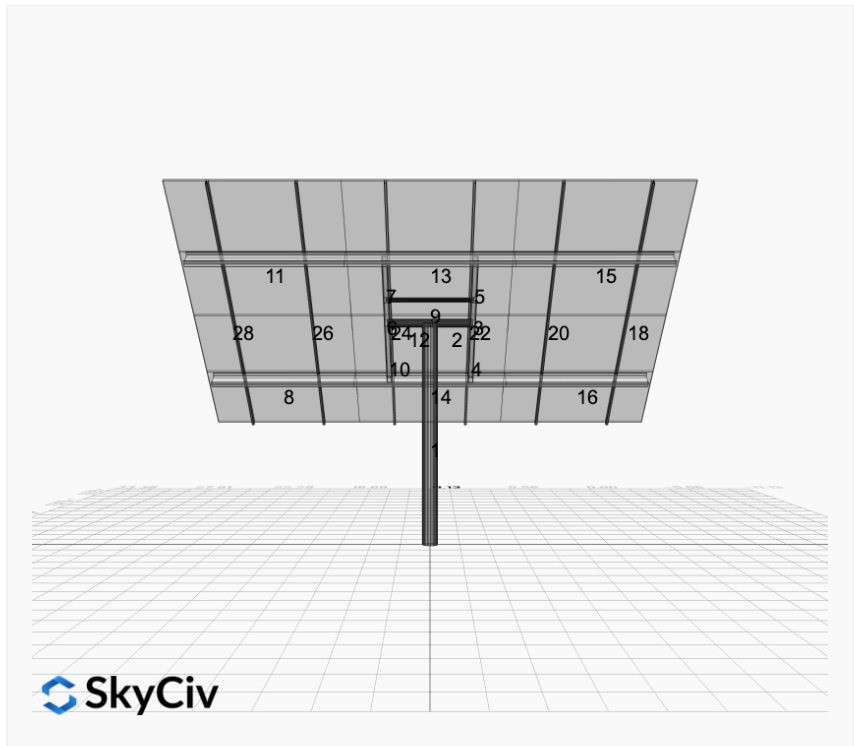
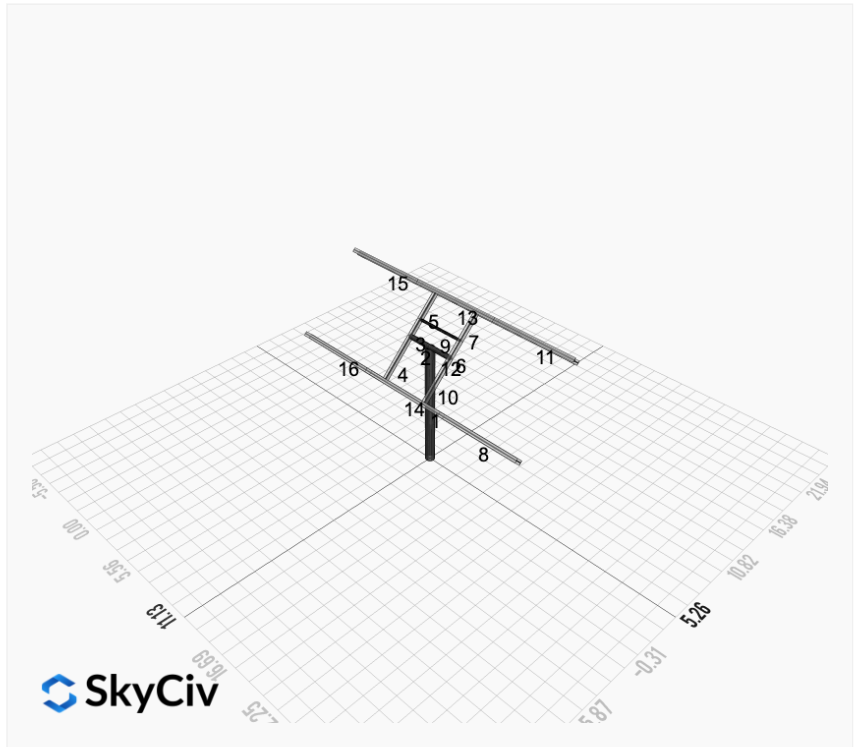

**Rail Design Check**

**Rail Length:** 15.033333333333333 ft  
**Additional Restraints Required:** None  
**Tributary Width:** 3.75 ft  
**Material:** Aluminium  
**Density:** 169 lb/ft<sup>3</sup>  
**Elasticity Modulus:** 10000 ksi  
**Fy:** 34.5 ksi  
**Fu:** 37 ksi  
**Snow (X):** 0.0292 kip/ft  
**Snow (Y):** -0.0292 kip/ft  
**Wind uplift Case A:** 0.0705 kip/ft  
**Wind uplift Case A:** 0.0705 kip/ft  
**Wind uplift Case B (X):** 0.0000 kip/ft  
**Wind uplift Case B (Y):** 0.0900 kip/ft



Result Check	Max Limit	Max Value	Utility	Status
Custom Stress Limit	34.5	19.53827136	0.566	PASS
Material Yield	34.5	19.53827136	0.566	PASS
Material Strength	37	19.53827136	0.528	PASS

**Member 1, ULS: 1. 1.4D**

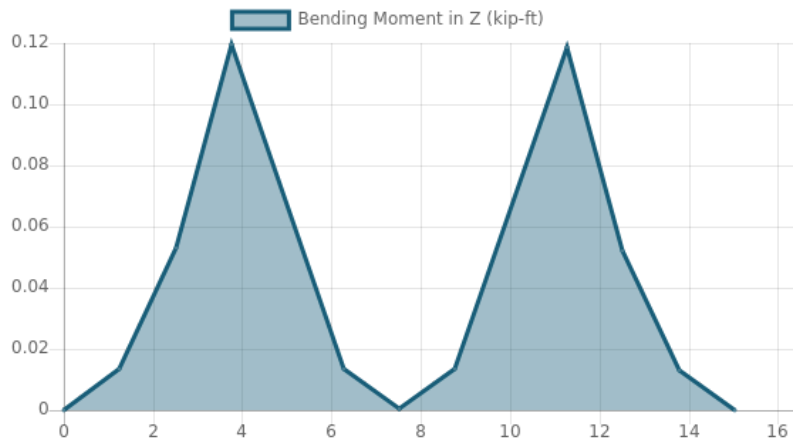

## FEM Results (Envelope Worst Case for each member)

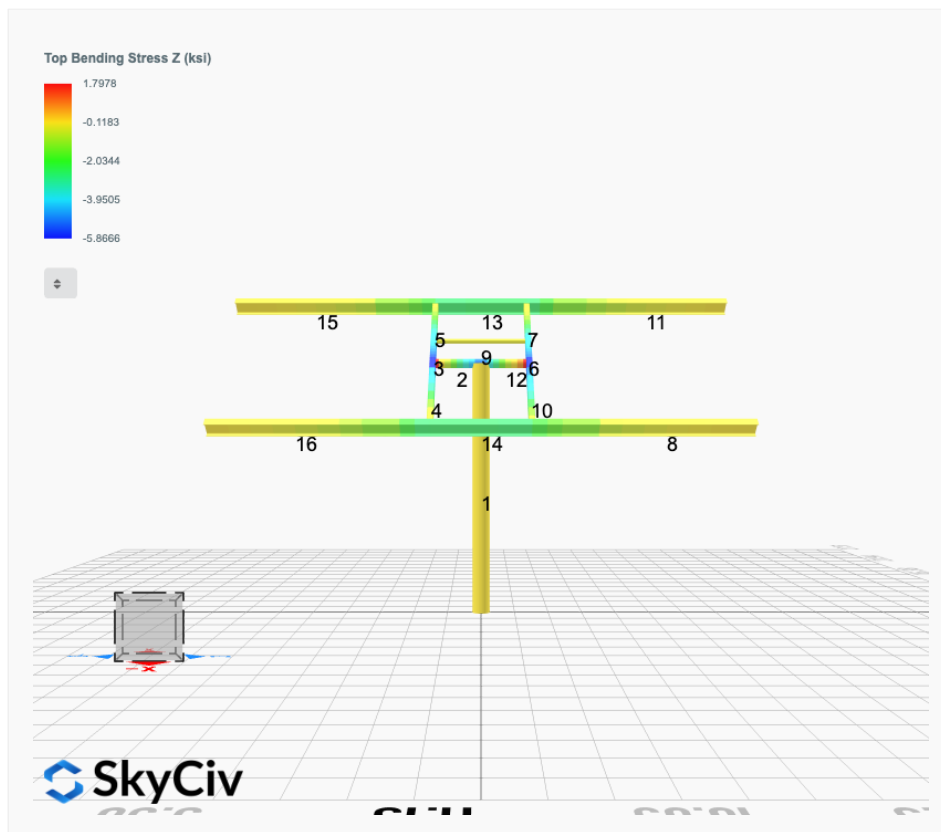
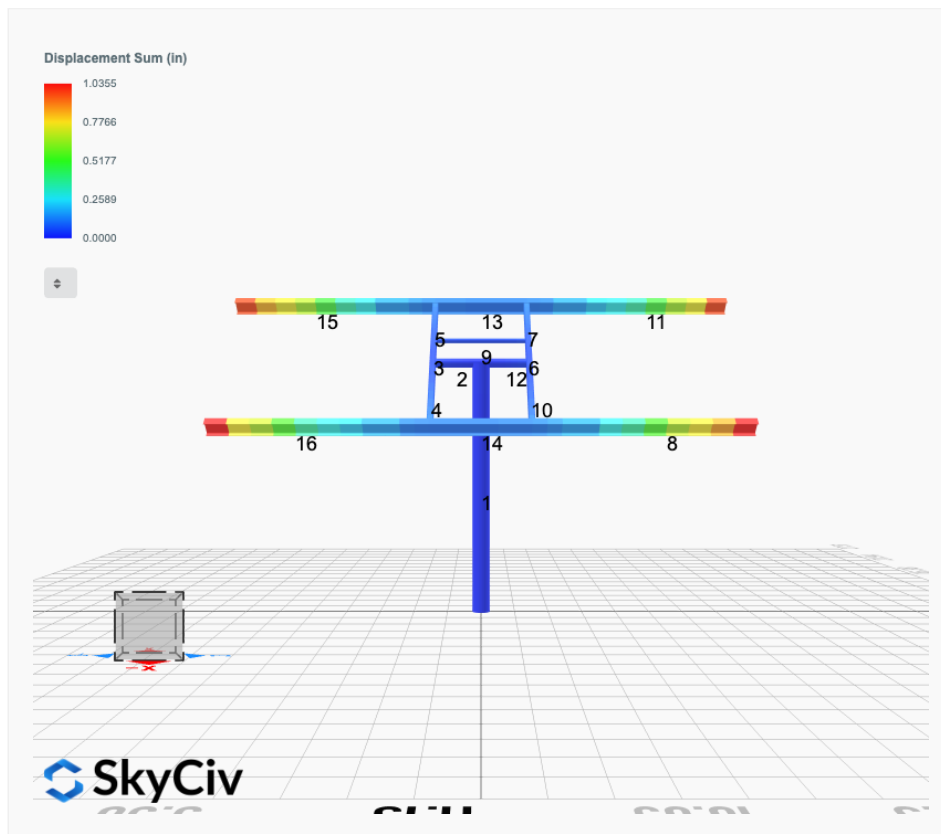

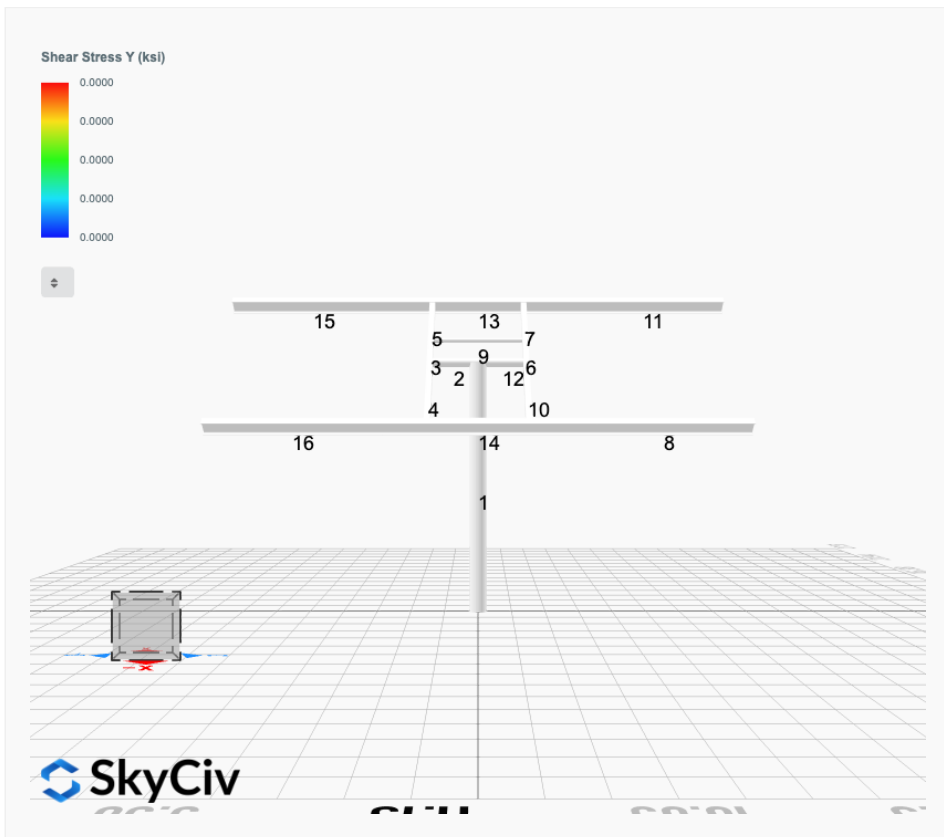
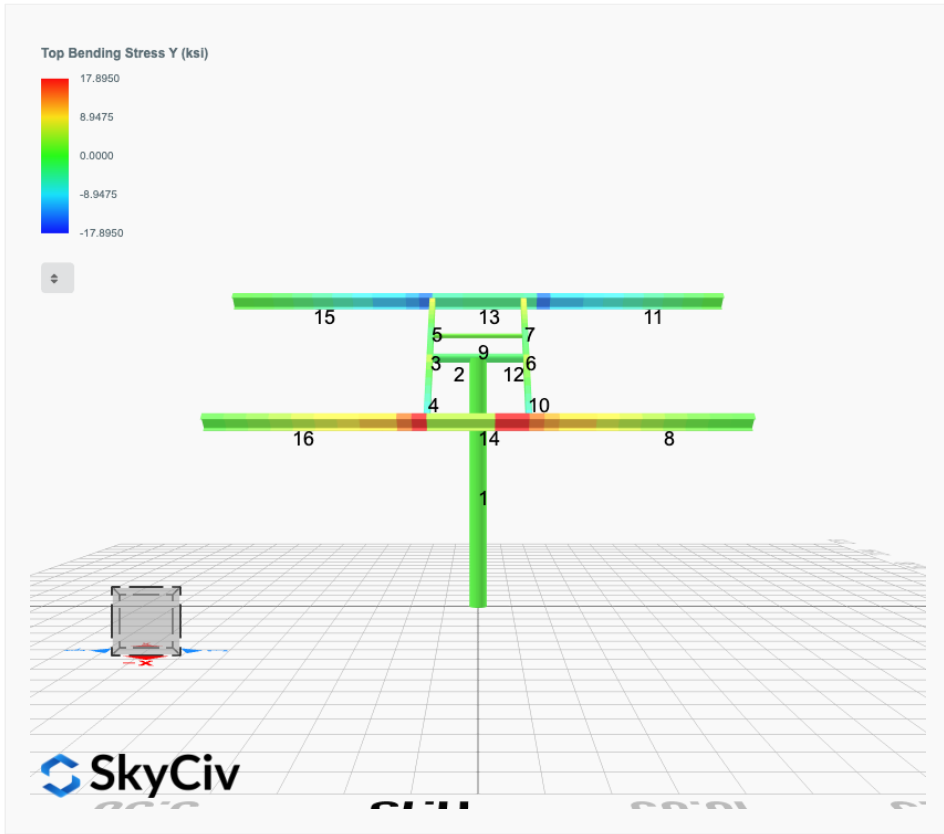

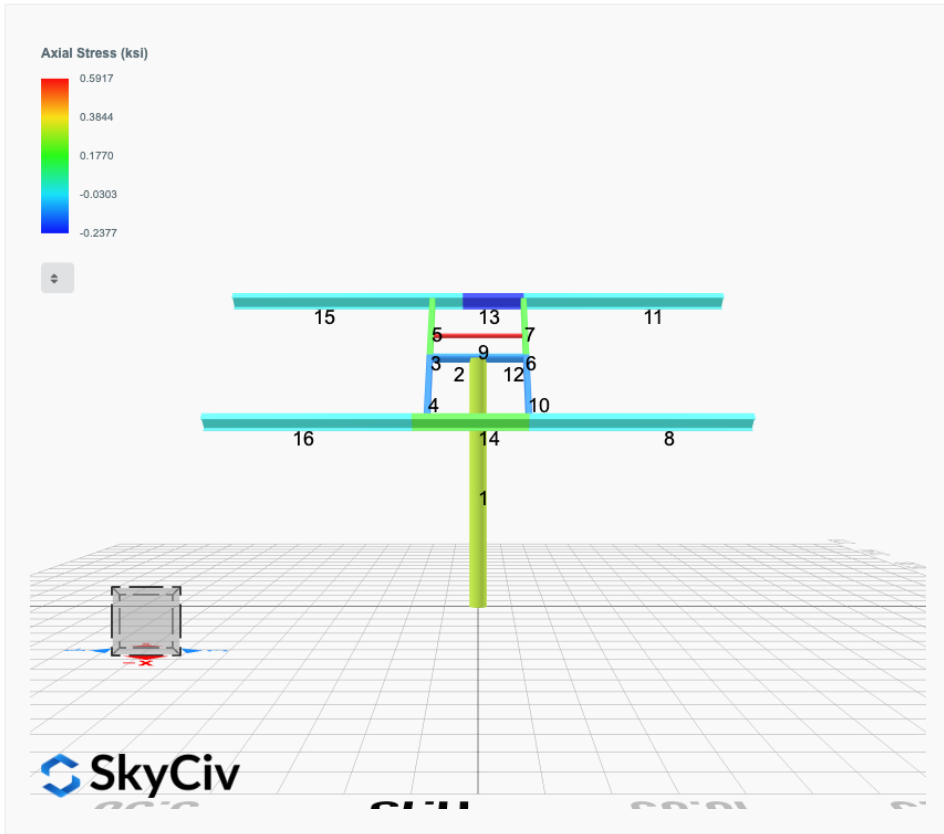

## Reaction Forces for Foundation 1 (Node ID#1), (kip, kip-ft)

### ASD Load Combination Results

Name	Fx	Fy	Fz	Mx	My	Mz
ULS: 1. D	-0.0000	2.4727	0.0000	0.0000	-0.0000	0.0235
ULS: 2. D + L	-0.0000	2.4727	0.0000	0.0000	-0.0000	0.0235
ULS: 3. D + (S or Lr or R)	-0.0000	4.9859	-0.0000	0.0000	-0.0000	0.0317
ULS: 3. D + (S or Lr or R)	-0.0000	2.4727	0.0000	0.0000	-0.0000	0.0235
ULS: 4. D + 0.75L + 0.75(S or Lr or R)	-0.0000	4.3576	0.0000	0.0000	-0.0000	0.0297
ULS: 4. D + 0.75L + 0.75(S or Lr or R)	-0.0000	2.4727	0.0000	0.0000	-0.0000	0.0235
ULS: 5b. D + 0.7E	-0.0000	2.4727	0.0000	0.0000	-0.0000	0.0235
ULS: 6b. D + 0.75L + 0.75(0.7)E + 0.75S	-0.0000	4.3576	0.0000	0.0000	-0.0000	0.0297
ULS: 8. 0.6D + 0.7E	-0.0000	1.4836	0.0000	0.0000	-0.0000	0.0141
ULS: 5a. D + 0.6W_Wind downforce Case A only	-3.5205	5.9932	0.0000	0.0000	-0.0000	38.0816
ULS: 5a. D + 0.6W_Wind downforce Case B only	-3.5205	5.9932	0.0000	0.0000	-0.0000	38.0816
ULS: 5a. D + 0.6W_Wind uplift Case A only	2.5467	-0.0740	0.0000	0.0000	-0.0000	-25.1961
ULS: 5a. D + 0.6W_Wind uplift Case B only	2.2471	0.2256	0.0000	0.0000	-0.0000	-29.2168
ULS: 6a. D + 0.75L + 0.75(0.6)W + 0.75(S or Lr or R)_Wind downforce Case A only	-2.6403	6.9979	0.0000	0.0000	-0.0000	28.5732
ULS: 6a. D + 0.75L + 0.75(0.6)W + 0.75(S or Lr or R)_Wind downforce Case B only	-2.6403	6.9979	0.0000	0.0000	-0.0000	28.5732
ULS: 6a. D + 0.75L + 0.75(0.6)W + 0.75(S or Lr or R)_Wind uplift Case A only	1.9100	2.4476	0.0000	0.0000	-0.0000	-18.8851
ULS: 6a. D + 0.75L + 0.75(0.6)W + 0.75(S or Lr or R)_Wind uplift Case B only	1.6853	2.6723	0.0000	0.0000	-0.0000	-21.9006
ULS: 6a. D + 0.75L + 0.75(0.6)W + 0.75(S or Lr or R)_Wind downforce Case A only	-2.6403	5.1130	0.0000	0.0000	-0.0000	28.5671
ULS: 6a. D + 0.75L + 0.75(0.6)W + 0.75(S or Lr or R)_Wind downforce Case B only	-2.6403	5.1130	0.0000	0.0000	-0.0000	28.5671
ULS: 6a. D + 0.75L + 0.75(0.6)W + 0.75(S or Lr or R)_Wind uplift Case A only	1.9100	0.5627	0.0000	0.0000	-0.0000	-18.8912
ULS: 6a. D + 0.75L + 0.75(0.6)W + 0.75(S or Lr or R)_Wind uplift Case B only	1.6853	0.7874	0.0000	0.0000	-0.0000	-21.9067
ULS: 7. 0.6D + 0.6W_Wind downforce Case A only	-3.5205	5.0041	0.0000	0.0000	-0.0000	38.0722
ULS: 7. 0.6D + 0.6W_Wind downforce Case B only	-3.5205	5.0041	0.0000	0.0000	-0.0000	38.0722
ULS: 7. 0.6D + 0.6W_Wind uplift Case A only	2.5467	-1.0631	0.0000	0.0000	-0.0000	-25.2055
ULS: 7. 0.6D + 0.6W_Wind uplift Case B only	2.2471	-0.7635	0.0000	0.0000	-0.0000	-29.2262

### Worst Case Reactions LRFD

These calculations are taken directly from the FEA via SkyCiv and are used in the Concrete Checks of the Foundation Module.  
Note: Worst case values are assumed as downforce wind load cases.

Result	Value (kip, kip-ft)
Axial	10.0913
Shear X	-5.8674
Shear Z	0.0000
Moment X	0.0000
Moment Y (Twist)	0.0000
Moment Z	64.2150

### Worst Case Reactions ASD

These results are taken from the worst case values in the above table and are used in the Soil Checks in the Foundation Module.  
Note: Worst case values are assumed as downforce wind load cases.

Result	Value (kip, kip-ft)
Axial	6.9979
Shear X	-3.5205
Shear Z	0.0000
Moment X	0.0000
Moment Y (Twist)	0.0000
Moment Z	38.0816

## Project Details

Design Code: AISC 360-16 LRFD  
 Provision: LRFD  
 Country: United States

User Name: sales@mtsolar.us  
 Project Name: MTSOLAR\_ELKIALHKEA3E  
 Unit System: imperial



## Design Input Information

Design Factors			
$\Phi_t$	$\Phi_c$	$\Phi_b$	$\Phi_v$
0.9	0.9	0.9	0.9

Design Materials			
ID	E (ksi)	F <sub>y</sub> (ksi)	F <sub>u</sub> (ksi)
1	29000	50	65

**Section Dimensions**

ID	Name	d (in)	t <sub>w</sub> (in)				
2	2in Pipe Sch 80	2.38	0.22				
5	4in Pipe Sch 80	4.50	0.34				
9	8in Pipe Sch 40	8.63	0.32				

ID	Name	d (in)	b (in)	t <sub>w</sub> (in)	t <sub>b</sub> (in)	r (in)	
16	HSS5x3x3/16	5.00	3.00	0.17	0.17	0.17	

ID	Name	d (in)	t <sub>w</sub> (in)	b <sub>t</sub> (in)	b <sub>b</sub> (in)	t <sub>t</sub> (in)	t <sub>b</sub> (in)	r (in)
19	W8x10	7.89	0.17	3.94	3.94	0.20	0.20	0.30

Section Properties								
ID	Name	A (in <sup>2</sup> )	J (in <sup>4</sup> )	I <sub>yp</sub> (in <sup>4</sup> )	I <sub>zp</sub> (in <sup>4</sup> )	I <sub>w</sub> (in <sup>6</sup> )	S <sub>yp</sub> (in <sup>3</sup> )	S <sub>zp</sub> (in <sup>3</sup> )
2	2in Pipe Sch 80	1.48	1.74	0.87	0.87	0.00	1.02	1.02
5	4in Pipe Sch 80	4.41	19.22	9.61	9.61	0.00	5.85	5.85



10	116.10	111.33	15.79	11.10	42.08	23.28
11	133.20	15.17	32.87	6.12	40.24	43.62
12	198.33	196.72	21.95	21.95	59.50	59.50
13	133.20	104.94	23.14	6.12	40.24	43.62
14	133.20	104.94	23.14	6.12	40.24	43.62
15	133.20	15.17	32.87	6.12	40.24	43.62
16	133.20	15.17	32.87	6.12	40.24	43.62

## Design Ratio

Member ID	P	M <sub>z</sub>	M <sub>y</sub>	V <sub>y</sub>	V <sub>z</sub>	(P,M <sub>z</sub> ,M <sub>y</sub> )	Worst LC	KL/r	δ	Status
1	0.047	0.771	0.000	0.052	0.000	0.795	#13	0.442	Not Required	Pass
2	0.009	0.377	0.278	0.082	0.049	0.657	#13	0.035	Not Required	Pass
3	0.010	0.685	0.076	0.069	0.017	0.703	#13	0.045	Not Required	Pass
4	0.010	0.619	0.281	0.062	0.056	0.712	#13	0.080	Not Required	Pass
5	0.010	0.425	0.294	0.068	0.077	0.473	#13	0.074	Not Required	Pass
6	0.010	0.685	0.076	0.069	0.017	0.703	#13	0.045	Not Required	Pass
7	0.010	0.425	0.294	0.068	0.077	0.473	#13	0.074	Not Required	Pass
8	0.000	0.179	0.420	0.042	0.017	0.566	#21	Not Required	Not Required	Pass
9	0.037	0.056	0.068	0.001	0.000	0.134	#13	0.204	Not Required	Pass
10	0.010	0.619	0.281	0.062	0.056	0.712	#13	0.080	Not Required	Pass
11	0.000	0.197	0.420	0.046	0.017	0.575	#21	Not Required	Not Required	Pass
12	0.009	0.377	0.278	0.082	0.049	0.657	#13	0.035	Not Required	Pass
13	0.013	0.441	0.656	0.058	0.021	0.996	#21	0.190	Not Required	Warn
14	0.012	0.408	0.656	0.052	0.021	0.976	#21	0.190	Not Required	Warn
15	0.000	0.197	0.420	0.046	0.017	0.575	#21	Not Required	Not Required	Pass
16	0.000	0.179	0.420	0.042	0.017	0.566	#21	Not Required	Not Required	Pass

## Definitions

$\Phi_t$	Safety factor for tensile
$\Phi_c$	Safety factor for compression
$\Phi_b$	Safety factor for flexure
$\Phi_v$	Safety factor for shear
E	Modulus of elasticity
F <sub>y</sub>	Specified minimum yield stress
F <sub>u</sub>	Specified minimum tensile strength
A	Cross-sectional area
J	Torsional constant
I <sub>yp</sub>	Moment of inertia about the Y axes
I <sub>zp</sub>	Moment of inertia about the Z axes
I <sub>w</sub>	Warping constant
S <sub>yp</sub>	Plastic section modulus about the Y axis
S <sub>zp</sub>	Plastic section modulus about the Z axis
KL	Effective length
C <sub>b</sub>	Buckling modification factor (from all load combinations)
L <sub>b</sub>	Length between braced points
LST	Limited slenderness for tension
LSC	Limited slenderness for compression
LD	Limited deflection
P <sub>n</sub>	Nominal axial strength (tension/compression)
M <sub>n</sub>	Nominal flexural strength (about Z/Y axis)
V <sub>n</sub>	Nominal shear strength (along Z/Y axis)
P	Design ratio in case of axial force
M <sub>z</sub>	Design ratio in case of bending about Z axis
M <sub>y</sub>	Design ratio in case of bending about Y axis
V <sub>y</sub>	Design ratio in case of shear along Y axis
V <sub>z</sub>	Design ratio in case of shear along Z axis
(P,M <sub>z</sub> ,M <sub>y</sub> )	Design ratio in case of axial force and bending action
KL/r	Design ratio in case of section slenderness
δ	Design ratio in case of member deflection
OK	Capacity is provided

ON  
NG

Capacity is provided  
Capacity is not provided

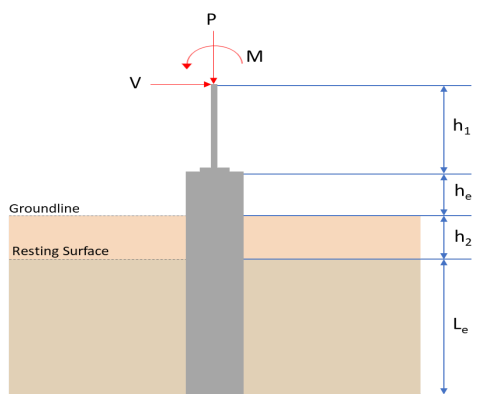
REFERENCES	CALCULATIONS	RESULTS																										
	<p><b>SkyCiv Foundation Design</b> Pile Foundation</p> <p><b>Design Information :</b> Design code : IBC 2021 (International Building Code) Unit System : Imperial</p>																											
	<p><b>Pile Input</b></p>  <p><b>Geometry</b> Pile shape: rectangular <math>b = 48</math> in - Pile width <math>D = 48</math> in - Pile depth <math>L = 7</math> ft - Total pile length <math>h_1 = 0</math> ft - Lateral load height from the top of the pile, <math>h_2 = 0</math> ft - Depth to resting surface <math>h_e = 0</math> ft - Length of pile above the ground</p> <p><b>Tabulation of Soil Parameters</b></p> <table border="1" data-bbox="414 1097 1189 1198"> <thead> <tr> <th>Layer</th> <th>Label</th> <th>Allowable Bearing Pressure (<math>q_a</math>) (psf)</th> <th>Allowable Lateral Pressure (<math>R</math>) (psf/ft)</th> </tr> </thead> <tbody> <tr> <td>1</td> <td>Sand, silty sand, clayey sand, silty gravel &amp; clayey gravel</td> <td>2000.000</td> <td>150.000</td> </tr> </tbody> </table> <p><b>Tabulation of Loads</b></p> <table border="1" data-bbox="670 1288 933 1456"> <thead> <tr> <th>Load Component</th> <th>ASD</th> <th>LRFD</th> </tr> </thead> <tbody> <tr> <td><math>P</math> (kip)</td> <td>6.998</td> <td>10.091</td> </tr> <tr> <td><math>V_x</math> (kip)</td> <td>-3.520</td> <td>-5.867</td> </tr> <tr> <td><math>V_z</math> (kip)</td> <td>0.000</td> <td>0.000</td> </tr> <tr> <td><math>M_x</math> (kipft)</td> <td>0.000</td> <td>0.000</td> </tr> <tr> <td><math>M_z</math> (kipft)</td> <td>38.082</td> <td>64.215</td> </tr> </tbody> </table> <p><b>Material Properties</b> <math>f'_{ck} = 2.5</math> ksi - Concrete strength,</p>	Layer	Label	Allowable Bearing Pressure ( $q_a$ ) (psf)	Allowable Lateral Pressure ( $R$ ) (psf/ft)	1	Sand, silty sand, clayey sand, silty gravel & clayey gravel	2000.000	150.000	Load Component	ASD	LRFD	$P$ (kip)	6.998	10.091	$V_x$ (kip)	-3.520	-5.867	$V_z$ (kip)	0.000	0.000	$M_x$ (kipft)	0.000	0.000	$M_z$ (kipft)	38.082	64.215	
Layer	Label	Allowable Bearing Pressure ( $q_a$ ) (psf)	Allowable Lateral Pressure ( $R$ ) (psf/ft)																									
1	Sand, silty sand, clayey sand, silty gravel & clayey gravel	2000.000	150.000																									
Load Component	ASD	LRFD																										
$P$ (kip)	6.998	10.091																										
$V_x$ (kip)	-3.520	-5.867																										
$V_z$ (kip)	0.000	0.000																										
$M_x$ (kipft)	0.000	0.000																										
$M_z$ (kipft)	38.082	64.215																										
	<p><b>Required depth to resist lateral loads (ASD)</b> <math>H</math> - Point of application of the lateral load</p> $H = h_1 + h_2 + h_e$ $H = (0 \text{ ft}) + (0 \text{ ft}) + (0 \text{ ft})$ $H = 0 \text{ ft}$ <p><b>Considering x-direction:</b> <math>H_o</math> - Lateral force per length of pile,</p> $H_o = \frac{V_x}{1.57 D}$ $H_o = \frac{(-3.52 \text{ kip})}{1.57 \times (48 \text{ in})}$ $H_o = -0.56051 \text{ kip/ft}$ <p><math>M_o</math> - Moment per length of pile,</p> $M_o = \frac{M_z + (V_x H)}{1.57 D}$																											

	$M_o = \frac{(38.082 \text{ kipft}) + ((-3.52 \text{ kip}) \times (0 \text{ ft}))}{1.57 \times (48 \text{ in})}$ $M_o = 6.064 \text{ kipft/ft}$ <p>Required depth of embedment in earth:</p> $L_x^3 - \left(14.14 \times \frac{H_o \times L_x}{R}\right) - \left(18.85 \times \frac{M_o}{R}\right) = 0$ <p>Solving the cubic equation:  <math>L_{e,x} = 6.4492 \text{ ft}</math> - Required depth in x-direction,</p> <p><b>Considering z-direction:</b>  <math>L_{e,z} = 0 \text{ ft}</math> - Required depth in z-direction,</p> <p><b>Minimum embedded depth required:</b>  <math>L_{e,req}</math> - Depth of pile required,</p> $L_{e,req} = \text{MAX}[L_{e,x}, L_{e,z}]$ $L_{e,req} = \text{MAX}[(6.4492 \text{ ft}), (0 \text{ ft})]$ $L_{e,req} = 6.449 \text{ ft}$ <p><math>L_e</math> - Actual embedded length of pile,</p> $L_e = L - h_e - h_2$ $L_e = (7 \text{ ft}) - (0 \text{ ft}) - (0 \text{ ft})$ $L_e = 7 \text{ ft}$ <p><b>Ratio</b> - Embedded depth</p> $\text{Ratio} = \frac{L_{e,req}}{L_e}$ $\text{Ratio} = \frac{(6.449 \text{ ft})}{(7 \text{ ft})}$ $\text{Ratio} = 0.92129$	<p>Status: <b>PASS</b>  Ratio: <b>0.920</b></p>
	<p><b>End-bearing Capacity (ASD)</b></p> <p>A - Pile cross-section area</p> $A = b D$ $A = (48 \text{ in}) \times (48 \text{ in})$ $A = 16 \text{ ft}^2$ <p>q - End-bearing pressure</p> $q = \frac{P_v}{A}$ $q = \frac{(6.998 \text{ kip})}{(16 \text{ ft}^2)}$ $q = 0.43737 \text{ kip/ft}^2$ <p><b>Check bearing capacity ratio:</b></p> <p><b>Ratio</b> - Capacity</p> $\text{Ratio} = \frac{q}{q_o}$ $\text{Ratio} = \frac{(0.43737 \text{ kip/ft}^2)}{(2000 \text{ psf})}$ $\text{Ratio} = 0.21869$	<p>Status: <b>PASS</b>  Ratio: <b>0.220</b></p>
<p>Czerniak</p>	<p><b>Lateral Soil Pressure (ASD):</b></p> <p><math>L/D</math> - Length to least lateral dimension ratio,</p> $L/D = \frac{L}{D}$ $L/D = \frac{(7 \text{ ft})}{(48 \text{ in})}$	

$$L/D = 1.75$$

Since  $L/D \leq 10$ ,

Pile is short.

**Considering x-direction:**

$H_o = -0.56051$  kip/ft - Lateral force per length of pile,

$M_o = 6.064$  kipft/ft - Overturning moment per length of pile,

$a$  - Distance from resting surface to pivot point,

$$a = \frac{(4 M_o L_e) + (3 H_o L_e^2)}{(6 M_o) + (4 H_o L_e)}$$

$$a = \frac{(4 \times (6.064 \text{ kipft/ft}) \times (7 \text{ ft})) + (3 \times (-0.56051 \text{ kip/ft}) \times (7 \text{ ft})^2)}{(6 \times (6.064 \text{ kipft/ft})) + (4 \times (-0.56051 \text{ kip/ft}) \times (7 \text{ ft}))}$$

$$a = 4.8425 \text{ ft}$$

$p$  - Earth pressure against the pile at distance  $a/2$  from resting surface,

$$p = \frac{0.75 [(4 M_o) + (3 H_o L_e)]^2}{L_e^2 [(3 M_o) + (2 H_o L_e)]}$$

$$p = \frac{0.75 \times [(4 \times (6.064 \text{ kipft/ft})) + (3 \times (-0.56051 \text{ kip/ft}) \times (7 \text{ ft}))]^2}{(7 \text{ ft})^2 \times [(3 \times (6.064 \text{ kipft/ft})) + (2 \times (-0.56051 \text{ kip/ft}) \times (7 \text{ ft}))]}$$

$$p = 0.23064 \text{ kip/ft}^2$$

$s$  - Earth pressure against the pile at distance  $L_e$ ,

$$s = \frac{6 [(2 M_o) + (H_o L_e)]}{L_e^2}$$

$$s = \frac{6 \times [(2 \times (6.064 \text{ kipft/ft})) + ((-0.56051 \text{ kip/ft}) \times (7 \text{ ft}))]}{(7 \text{ ft})^2}$$

$$s = 1.0046 \text{ kip/ft}^2$$

**Check lateral soil pressure capacity:**

$p_a$  - Allowable lateral soil pressure at depth  $a/2$ ,

$$p_a = R \frac{a}{2}$$

$$p_a = (150 \text{ psf/ft}) \times \frac{(4.8425 \text{ ft})}{2}$$

$$p_a = 0.36318 \text{ kip/ft}^2$$

*Ratio* - Lateral soil capacity

$$\text{Ratio} = \frac{p}{p_a}$$

$$\text{Ratio} = \frac{(0.23064 \text{ kip/ft}^2)}{(0.36318 \text{ kip/ft}^2)}$$

$$\text{Ratio} = 0.63506$$

$p_s$  - Allowable lateral soil pressure at depth  $L_e$ ,

$$p_s = R L_e$$

$$p_s = (150 \text{ psf/ft}) \times (7 \text{ ft})$$

$$p_s = 1.05 \text{ kip/ft}^2$$

*Ratio* - Lateral soil capacity

$$\text{Ratio} = \frac{s}{p_s}$$

$$\text{Ratio} = \frac{(1.0046 \text{ kip/ft}^2)}{(1.05 \text{ kip/ft}^2)}$$

$$\text{Ratio} = 0.95679$$

Status: **PASS**  
Ratio: **0.640**

Status: **PASS**  
Ratio: **0.960**

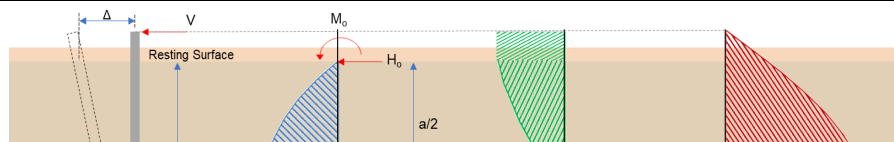

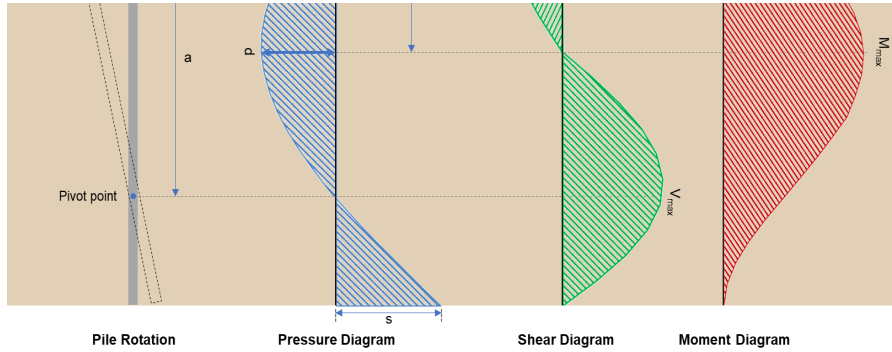

### Shear force and Bending moment (x-direction, LRFD)

$H_o$  - Lateral force per length of pile,

$$H_o = \frac{V_x}{1.57 D}$$

$$H_o = \frac{(-5.867 \text{ kip})}{1.57 \times (48 \text{ in})}$$

$$H_o = -0.93424 \text{ kip/ft}$$

$M_o$  - Moment per length of pile,

$$M_o = \frac{M_x + (V_x H)}{1.57 D}$$

$$M_o = \frac{(64.215 \text{ kipft}) + ((-5.867 \text{ kip}) \times (0 \text{ ft}))}{1.57 \times (48 \text{ in})}$$

$$M_o = 10.225 \text{ kipft/ft}$$

$E$  - Distance from lateral load to resisting surface,

$$E = \frac{M_o}{H_o}$$

$$E = \frac{(10.225 \text{ kipft/ft})}{(-0.93424 \text{ kip/ft})}$$

$$E = 10.945 \text{ ft}$$

$a$  - Distance from resting surface to pivot point,

$$a = \frac{(4 M_o L_c) + (3 H_o L_c^2)}{(6 M_o) + (4 H_o L_c)}$$

$$a = \frac{(4 \times (10.225 \text{ kipft/ft}) \times (7 \text{ ft})) + (3 \times (-0.93424 \text{ kip/ft}) \times (7 \text{ ft})^2)}{(6 \times (10.225 \text{ kipft/ft})) + (4 \times (-0.93424 \text{ kip/ft}) \times (7 \text{ ft}))}$$

$$a = 4.841 \text{ ft}$$

$V_{max}$  - Max shear force located at depth  $a$ ,

$$V_{max} = (H_o D) \left[ 1 - \left[ 3 \left( \frac{4 E}{L_c} + 3 \right) \left( \frac{a}{L_c} \right)^2 \right] + \left[ 4 \left( \frac{3 E}{L_c} + 2 \right) \left( \frac{a}{L_c} \right)^3 \right] \right]$$

$$V_{max} = ((-0.93424 \text{ kip/ft}) \times (48 \text{ in})) \times \left[ 1 - \left[ 3 \times \left( \frac{4 \times (10.945 \text{ ft})}{(7 \text{ ft})} + 3 \right) \times \left( \frac{(4.841 \text{ ft})}{(7 \text{ ft})} \right)^2 \right] + \left[ 4 \times \left( \frac{3 \times (10.945 \text{ ft})}{(7 \text{ ft})} + 2 \right) \times \left( \frac{(4.841 \text{ ft})}{(7 \text{ ft})} \right)^3 \right] \right]$$

$$V_{max} = 12.803 \text{ kip}$$

$M_{max}$  - Max bending moment located at depth  $a/2$ ,

$$M_{max} = (H_o D L_c) \left[ \left( \frac{E}{L_c} + \frac{a}{2 L_c} \right) - \left[ \left( \frac{4 E}{L_c} + 3 \right) \left( \frac{a}{2 L_c} \right)^3 \right] + \left[ \left( \frac{3 E}{L_c} + 2 \right) \left( \frac{a}{2 L_c} \right)^4 \right] \right]$$

$$M_{max} = ((-0.93424 \text{ kip/ft}) \times (48 \text{ in}) \times (7 \text{ ft})) \times \left[ \left( \frac{(10.945 \text{ ft})}{(7 \text{ ft})} + \frac{(4.841 \text{ ft})}{2 \times (7 \text{ ft})} \right) - \left[ \left( \frac{4 \times (10.945 \text{ ft})}{(7 \text{ ft})} + 3 \right) \times \left( \frac{(4.841 \text{ ft})}{2 \times (7 \text{ ft})} \right)^3 \right] + \left[ \left( \frac{3 \times (10.945 \text{ ft})}{(7 \text{ ft})} + 2 \right) \times \left( \frac{(4.841 \text{ ft})}{2 \times (7 \text{ ft})} \right)^4 \right] \right]$$

$$M_{max} = 42.44 \text{ kipft}$$

### Minimum Reinforcement Check (LRFD)

#### Parameters:

$f'_{ck} = 2.5 \text{ ksi}$  - Concrete strength,  
 $f_{yk} = 60 \text{ ksi}$  - Longitudinal reinforcement strength,  
 $\phi = 0.65$  - Reduction factor for axial strength,  
 $\alpha = 0.8$  - Alpha factor for axial strength,  
 $A_g = 2304 \text{ in}^2$  - Gross area of concrete,

Table 22.4.2.1

#### Longitudinal reinforcement:

Required reinforcement due to axial load,  $A_{st,required}$

22.4.2.2, 10.6.1.1

$A_{st,required}$

$$A_{st,required} = \text{Min} \left[ \frac{\frac{P}{\phi \alpha} - (0.85 f'_{ck} A_g)}{f_{yk} - (0.85 f'_{ck})}, (0.08 A_g) \right]$$

$$A_{st,required} = \text{Min} \left[ \frac{\frac{(10.091 \text{ kip})}{(0.65) \times (0.8)} - (0.85 \times (2.5 \text{ ksi}) \times (2304 \text{ in}^2))}{(60 \text{ ksi}) - (0.85 \times (2.5 \text{ ksi}))}, (0.08 \times (2304 \text{ in}^2)) \right]$$

$$A_{st,required} = -84.261 \text{ in}^2$$

$A_{min}$  - Governing minimum reinforcement area,

$$A_{min} = \text{Max} [A_{st,required}, (0.0018 A_g)]$$

$$A_{min} = \text{Max} [(-84.261 \text{ in}^2), (0.0018 \times (2304 \text{ in}^2))]$$

$$A_{min} = 4.1472 \text{ in}^2$$

$n_{rebar}$  - Required number of reinforcement,

$$n_{rebar} = \frac{A_{min}}{A_{rebar}}$$

$$n_{rebar} = \frac{(4.1472 \text{ in}^2)}{(0.3068 \text{ in}^2)}$$

$$n_{rebar} = 14$$

$A_{st}$  - Actual total reinforcement area,

$$A_{st} = n_{rebar} \frac{\pi d_{bar}^2}{4}$$

$$A_{st} = (14) \times \frac{\pi \times (0.625 \text{ in})^2}{4}$$

$$A_{st} = 4.2951 \text{ in}^2$$

Ratio - Capacity

$$\text{Ratio} = \frac{A_{min}}{A_{st}}$$

$$\text{Ratio} = \frac{(4.1472 \text{ in}^2)}{(4.2951 \text{ in}^2)}$$

$$\text{Ratio} = 0.96556$$

Status: **PASS**  
Ratio: **0.970**

25.2.3

$s_{rebar}$  - Minimum spacing of reinforcement,

$$s_{rebar} = \text{Max} [1.5, (1.5 d_{bar})]$$

$$s_{rebar} = \text{Max} [1.5, (1.5 \times (0.625 \text{ in}))]$$

$$s_{rebar} = 1.5 \text{ in}$$

#### Ties:

25.7.2.2 Since longitudinal reinforcement is  $\leq$  No. 10 $\emptyset$ : Use #3(0.375 in)

25.7.2.1

$s_{ties}$  - Maximum spacing of ties,

$$s_{ties} = \text{Min} [(16 d_{bar}), (48 d_{ties}), \text{Min} (D, b)]$$

$$s_{ties} = \text{Min} [(16 \times (0.625 \text{ in})), (48 \times (0.375 \text{ in})), \text{Min} ((48 \text{ in}), (48 \text{ in}))]$$

$$s_{ties} = 10 \text{ in}$$

#### Summary:

Main reinforcement: **14 - #5 (0.625 in)**

**Axial Compression Strength (ACI 318-19, LRFD)**22.4.2.2  $\phi P_N$  - Allowable axial compressive strength

$$\phi P_N = \phi 0.80 [(0.85 f'_{ck} [A_g - A_{st}] + (f_{yk} A_{st})]$$

$$\phi P_N = (0.65) \times 0.80 \times [(0.85 \times (2.5 \text{ ksi}) \times [(2304 \text{ in}^2) - (4.2951 \text{ in}^2)]) + ((60 \text{ ksi}) \times (4.2951 \text{ in}^2))]$$

$$\phi P_N = 2675.2 \text{ kip}$$

Ratio - Capacity

$$\text{Ratio} = \frac{P}{\phi P_N}$$

$$\text{Ratio} = \frac{(10.091 \text{ kip})}{(2675.2 \text{ kip})}$$

$$\text{Ratio} = 0.0037721$$

Status: **PASS**  
Ratio: **0.000****Shear Strength (ACI 318-19, LRFD)****Parameters:** $b_w = 48 \text{ in}$  - Effective width,22.5.2.2  $d$  - Effective depth

$$d = 0.80 D$$

$$d = 0.80 \times (48 \text{ in})$$

$$d = 38.4 \text{ in}$$

22.5.5.1.3  $\lambda_s$  - size effect modification factor

$$\lambda_s = \text{MIN} \left[ \sqrt{\frac{2}{1 + \frac{d}{10}}}, 1 \right]$$

$$\lambda_s = \text{MIN} \left[ \sqrt{\frac{2}{1 + \frac{(38.4 \text{ in})}{10}}}, 1 \right]$$

$$\lambda_s = 0.64282$$

The following variables were converted to be consistent with empirical formula  $f'_{ck} = 2.5 \text{ ksi} \rightarrow 2500 \text{ psi}$ ,22.5.5.1.1  $V_{c,max}$  - Max shear strength of concrete

$$V_{c,max} = 5 \lambda_s \sqrt{f'_{ck}} b_w d$$

$$V_{c,max} = 5 \times (0.64282) \times \sqrt{(2500 \text{ psi})} \times (48 \text{ in}) \times (38.4 \text{ in})$$

$$V_{c,max} = 296.21 \text{ kip}$$

The following variables were converted to be consistent with empirical formula  $f'_{ck} = 2.5 \text{ ksi} \rightarrow 2500 \text{ psi}$ ,  $P = 10.091 \text{ kip} \rightarrow 10091 \text{ lbf}$ ,22.5.5.1.1(a)  $V_{c,a}$  - Shear strength of concrete (a)

$$V_{c,a} = \left[ 2 \lambda_s \sqrt{f'_{ck}} + \frac{P}{6 A_g} \right] b_w d$$

$$V_{c,a} = \left[ 2 \times (0.64282) \times \sqrt{(2500 \text{ psi})} + \frac{(10091 \text{ lbf})}{6 \times (2304 \text{ in}^2)} \right] \times (48 \text{ in}) \times (38.4 \text{ in})$$

$$V_{c,a} = 119.83 \text{ kip}$$

The following variables were converted to be consistent with empirical formula  $f'_{ck} = 2.5 \text{ ksi} \rightarrow 2500 \text{ psi}$ ,22.5.5.1.2  $V_{c,b}$  - Shear strength of concrete (b)

$$V_{c,b} = \left[ 2 \lambda_s \sqrt{f'_{ck}} + (0.05 f'_{ck}) \right] b_w d$$

$$V_{c,b} = \left[ 2 \times (0.64282) \times \sqrt{(2500 \text{ psi})} + (0.05 \times (2500 \text{ psi})) \right] \times (48 \text{ in}) \times (38.4 \text{ in})$$

$$V_{c,b} = 348.89 \text{ kip}$$

 $V_c$  - Governing shear strength of concrete

$$V_c = \text{Min}[V_{c,max}, V_{c,a}, V_{c,b}]$$

$$V_c = \text{Min}[(296.21 \text{ kip}), (119.83 \text{ kip}), (348.89 \text{ kip})]$$

$$V_c = 119.83 \text{ kip}$$

<p>22.5.1.2</p>	<p>The following variables were converted to be consistent with empirical formula <math>f'_{ck} = 2.5 \text{ ksi} \rightarrow 2500 \text{ psi}</math>,</p> <p><math>V_{s,a}</math> - Shear strength of steel (a)</p> $V_{s,a} = 8 \sqrt{f'_{ck}} b_w d$ $V_{s,a} = 8 \times \sqrt{(2500 \text{ psi})} \times (48 \text{ in}) \times (38.4 \text{ in})$ $V_{s,a} = 737.28 \text{ kip}$ <p><math>A_v</math> - Ties rebar area,</p> $A_v = \frac{\pi d_{ties}^2}{4}$ $A_v = \frac{\pi \times (0.375 \text{ in})^2}{4}$ $A_v = 0.11045 \text{ in}^2$ <p>22.5.8.5.3 <math>V_{s,b}</math> - Shear strength of steel (b)</p> $V_{s,b} = \frac{2 A_v f_{yw} d}{s_{ties}}$ $V_{s,b} = \frac{2 \times (0.11045 \text{ in}^2) \times (60 \text{ ksi}) \times (38.4 \text{ in})}{(10 \text{ in})}$ $V_{s,b} = 50.894 \text{ kip}$ <p><math>V_s</math> - Governing shear strength of steel</p> $V_s = \text{MIN}[V_{s,a}, V_{s,b}]$ $V_s = \text{MIN}[(737.28 \text{ kip}), (50.894 \text{ kip})]$ $V_s = 50.894 \text{ kip}$ <p>22.5.1.1 <math>\phi V_n</math> - Allowable shear strength</p> $\phi V_n = \phi (V_c + V_s)$ $\phi V_n = (0.65) \times ((119.83 \text{ kip}) + (50.894 \text{ kip}))$ $\phi V_n = 110.97 \text{ kip}$ <p><b>Considering x-direction:</b></p> <p><math>V_{max} = 12.803 \text{ kip}</math> - Maximum shear force in the x-direction,  <b>Ratio</b> - Capacity</p> $\text{Ratio} = \frac{V_{max}}{\phi V_n}$ $\text{Ratio} = \frac{(12.803 \text{ kip})}{(110.97 \text{ kip})}$ $\text{Ratio} = 0.11538$	<p>Status: <b>PASS</b>  Ratio: <b>0.120</b></p>
<p>14.5.2.1b</p>	<p><b>Flexural Strength (ACI 318-19, LRFD)</b></p> <p><math>S_m</math> - Section modulus</p> $S_m = \frac{b D^2}{6}$ $S_m = \frac{(48 \text{ in}) \times (48 \text{ in})^2}{6}$ $S_m = 18432 \text{ in}^3$ <p><math>\lambda = 1</math> - Concrete modification factor (Normal concrete),  Allowable flexural strength:  <math>M_n</math> shall be the lesser of:</p> <p><math>\phi M_{n,1}</math></p> $\phi M_{n,1} = \phi \times 5 \times \lambda \times \sqrt{f'_c} \times S_m$ $\phi M_{n,1} = 0.65 \times 5 \times 1 \times \sqrt{(2.5 \text{ ksi})} \times 18432.001 \text{ in}^3$ $\phi M_{n,1} = 249.600 \text{ kipft}$ <p><math>\phi M_{n,2}</math></p> $\phi M_{n,2} = 0.85 f'_c S_m$	

$\phi M_{n,2} = \phi M_{n,1}$

$$\phi M_{n,2} = (0.65) \times 0.85 \times (2.5 \text{ ksi}) \times (18432 \text{ in}^3)$$

$$\phi M_{n,2} = 2121.6 \text{ kipft}$$

Therefore,

$\phi M_n$  - Allowable flexural strength,

$$\phi M_n = \text{MIN}[\phi M_{n,1}, \phi M_{n,2}]$$

$$\phi M_n = \text{MIN}[(249.6 \text{ kipft}), (2121.6 \text{ kipft})]$$

$$\phi M_n = 249.6 \text{ kipft}$$

**Considering x-direction:**

$M_{max} = 42.44 \text{ kipft}$  - Maximum moment in the x-direction,

*Ratio* - Capacity

$$\text{Ratio} = \frac{M_{max}}{\phi M_n}$$

$$\text{Ratio} = \frac{(42.44 \text{ kipft})}{(249.6 \text{ kipft})}$$

$$\text{Ratio} = 0.17003$$

Status: **PASS**  
Ratio: **0.170**