

Project Name: TownofCG-TownHall 5ftsquare 2ft ExpB
- V1Jb

Date: Thu Apr 10 2025

Location: 4058 County Hwy N, Cottage Grove, WI
53527, USA

Number of Modules: 16

Number of Poles: 1

Unique ID: 1P-0-6TOP-SD-84-L-4Hx4W-STRUTS-D58I

Date Sold:

Dealer: _____

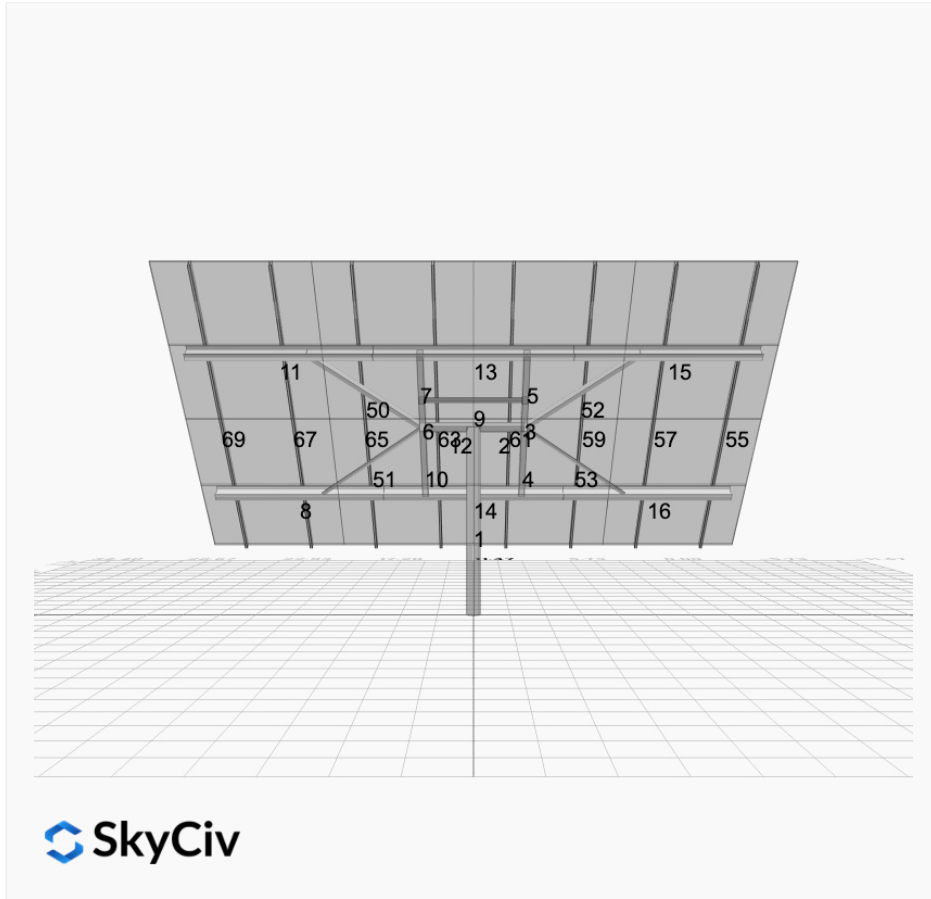

Array Dimensions N/S	15.03 ft
Array Dimensions E/W	22.93 ft
Winter Tilt Angle	46
Front Edge Clearance	2 ft

MT Solar Bill of Materials (1P-0-6TOP-SD-84-L-4Hx4W-STRUTS-D58I)

Part	Short Description	BOM Qty
MTS-PC-6	6IN Pole Cap Assembly	1
MTS-HF-SD	H-Frame Assembly-SD	1
MTS-SD-Wing-84	84IN SD Wing	4
MTS-CLAMP-HOOK-4PK	Hook Clamp	4

Rail Bill of Materials

Part	Qty
Rails (180in)	8
Rail Attachment	16
Module Mid Clamp	24

Part	Qty
Module End Clamp	16
Ground Lug	4

Site Details:

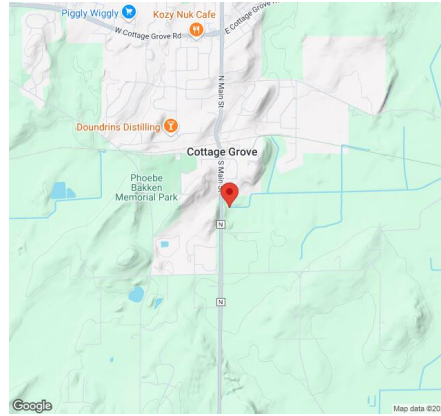

Site Address: 4058 County Hwy N, Cottage Grove, WI 53527, USA

Array Specification

Duty Classification:	SD
Module Width:	44.60 in
Module Length:	67.80in
Number of Rows:	4
Number of Columns:	4
Total Number of Modules:	16
Winter Tilt Angle:	46
Front Edge Clearance:	2
Total Array Height at Tilt:	12.81 ft
Total Frame Length:	21.50 ft
Module Info/Notes:	SIL-430 QD
Array Dimensions N/S:	15.03 ft
Array Dimensions E/W:	22.93 ft
Rail Length:	180.40 in
Rail Spacing:	2.87 ft

Support Specifications

Pole Size:	6in Pipe Sch 40
Pole Length above Grade:	7.41 ft
Number of Poles:	1
Pole Spacing:	0

Foundation Specifications

Foundation Type:	Square
Foundation Dimensions:	60 x 60 in
Foundation Depth (below grade):	Pile 1: 4.75 ft
Foundation Volume:	4.398 y ³

Site Info

Risk Category:	I
Exposure:	B
Soil Classification:	sand
Site Location:	4058 County Hwy N, Cottage Grove, WI 53527, USA
Wind Speed:	100 mph
Snow Load:	30 psf

Design Disclaimer

This software should be used for preliminary designs and should not be used as a final design unless reviewed, verified and designed by a qualified structural engineer.

AutoDesigner Input

```
{ "wind_speed_override": null, "snow_load_override": null, "direct_snow_load": false, "add_angle_brace": true, "product_type": "Beam", "designer_name": "TomLB", "designer_email": "tomlb@mwsolarpower.com", "designer_phone": "6083542063", "project_id": "TownofCG-TownHall 5ftsquare 2ft ExpB - V1Jb", "site_address": "4058 County Hwy N, Cottage Grove, WI 53527, USA", "module_info": "SIL-430 QD", "module_width": 44.6, "module_length": 67.8, "number_rows": 4, "number_columns": 4, "pole_mount_section": "4_40", "core_pipe_width": 65, "core_pipe_section": "2_40", "adjuster_section": "2_40", "core_beam_height": 65, "core_beam_section": "HSS3x2x1/8", "main_pipe_section": "2_12GA", "pole_spacing": "15", "tilt_angle": 46, "ground_clearance": 2, "risk_category": "I", "exposure_category": "B", "frame_duty_override": "auto", "pole_override": "auto", "soil_type": "sand", "customer_foundation_override": "48_Square", "foundation_type": "Square", "foundation_size": 60, "check_rails": false }
```

Design Notes:

- AISC Deflection checks are set to L/1 due to structure design intent
- Foundation Soil Parameters used in this Autodesign are all estimates, proper geotechnical reports are required to confirm soil profiles
- Wind speeds, snow loads and other site specific results are based on ASCE 7 2016
- Steel frame design checks are based on AISC 360 2016 (LRFD)

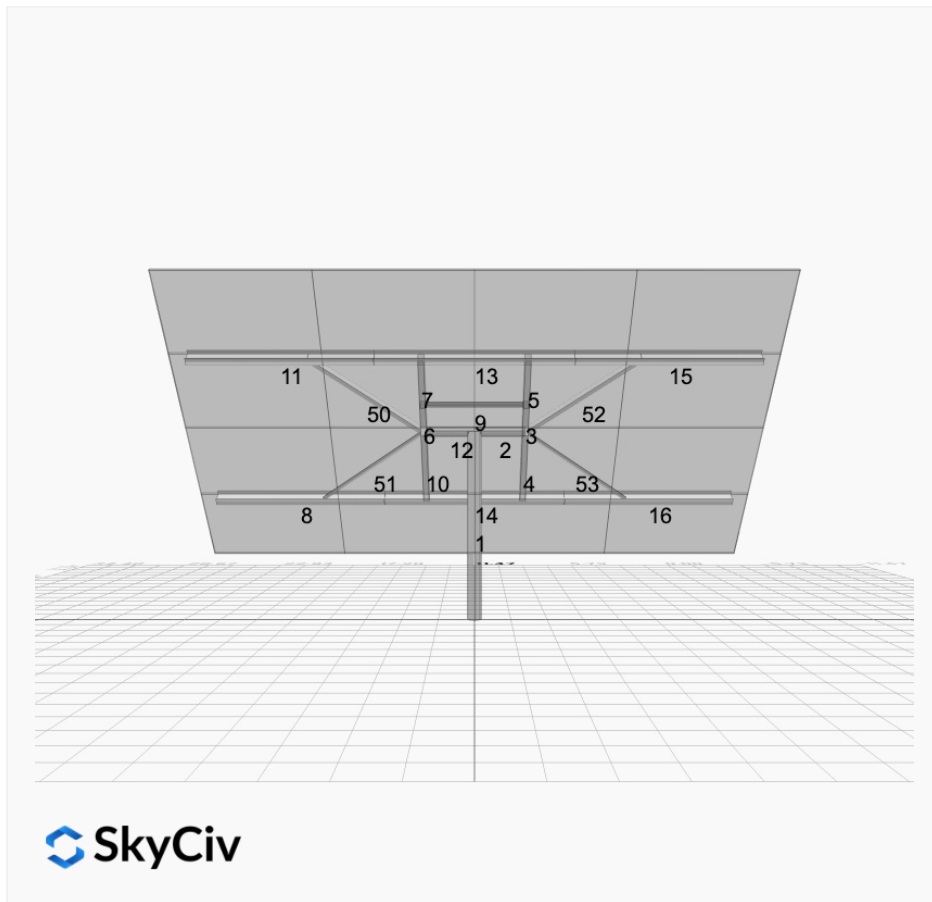

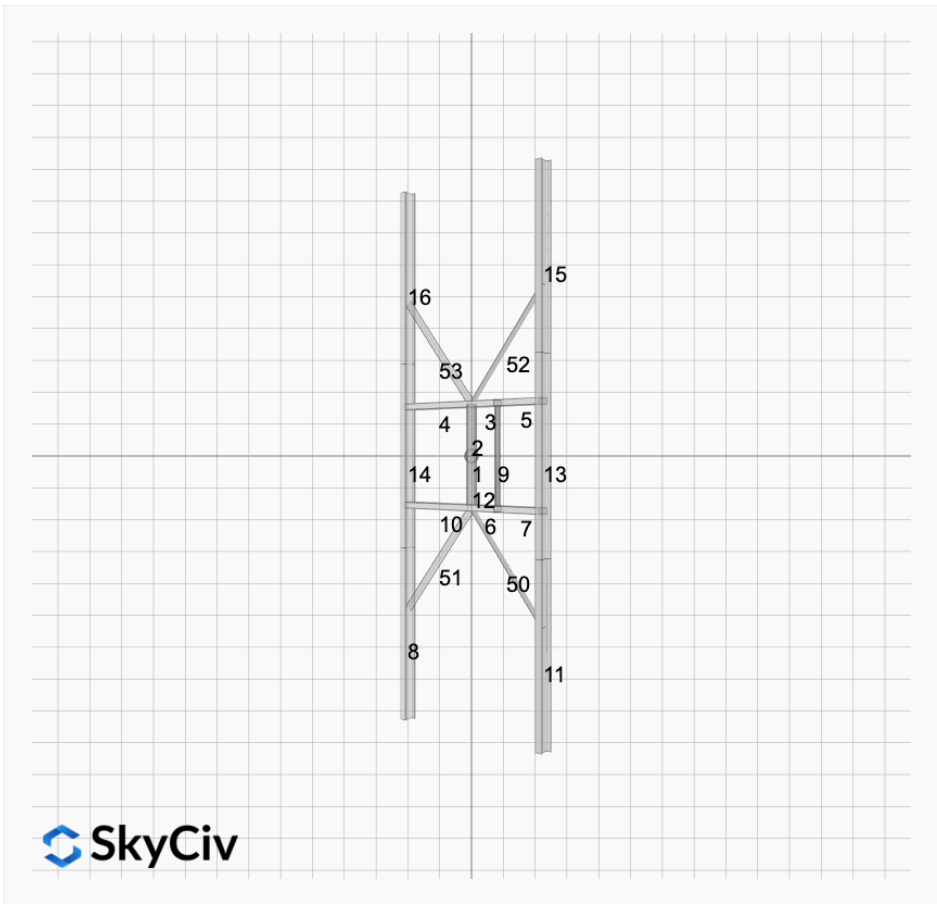
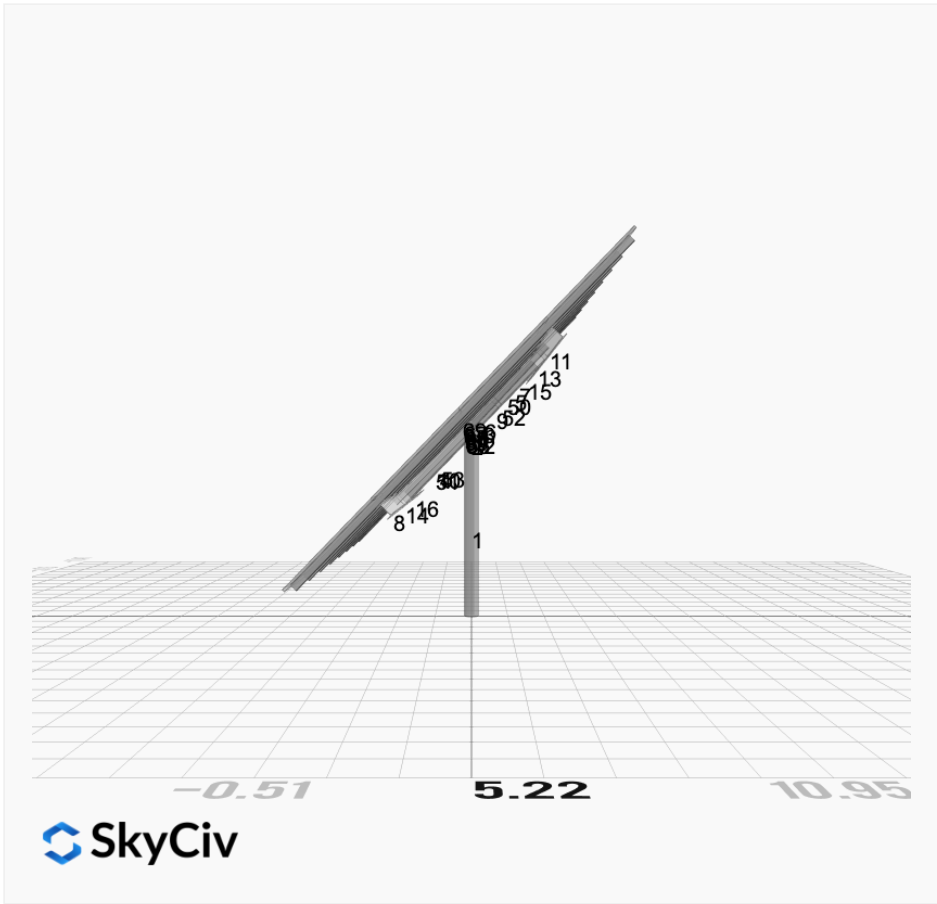

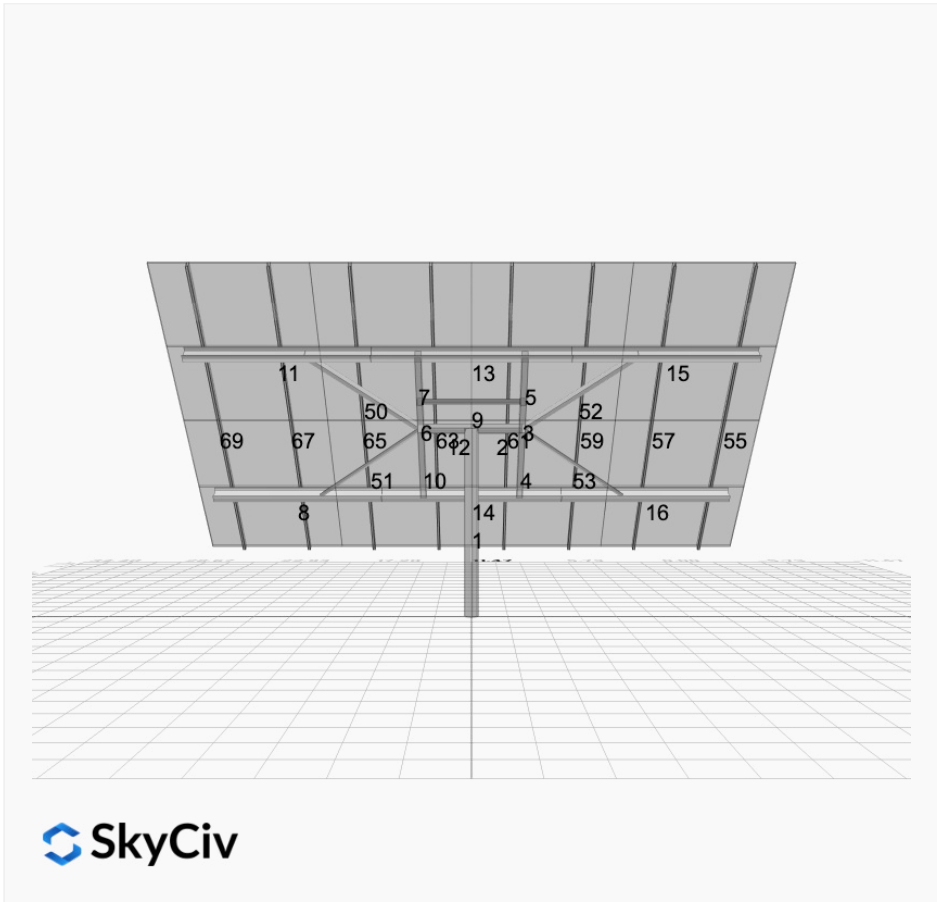
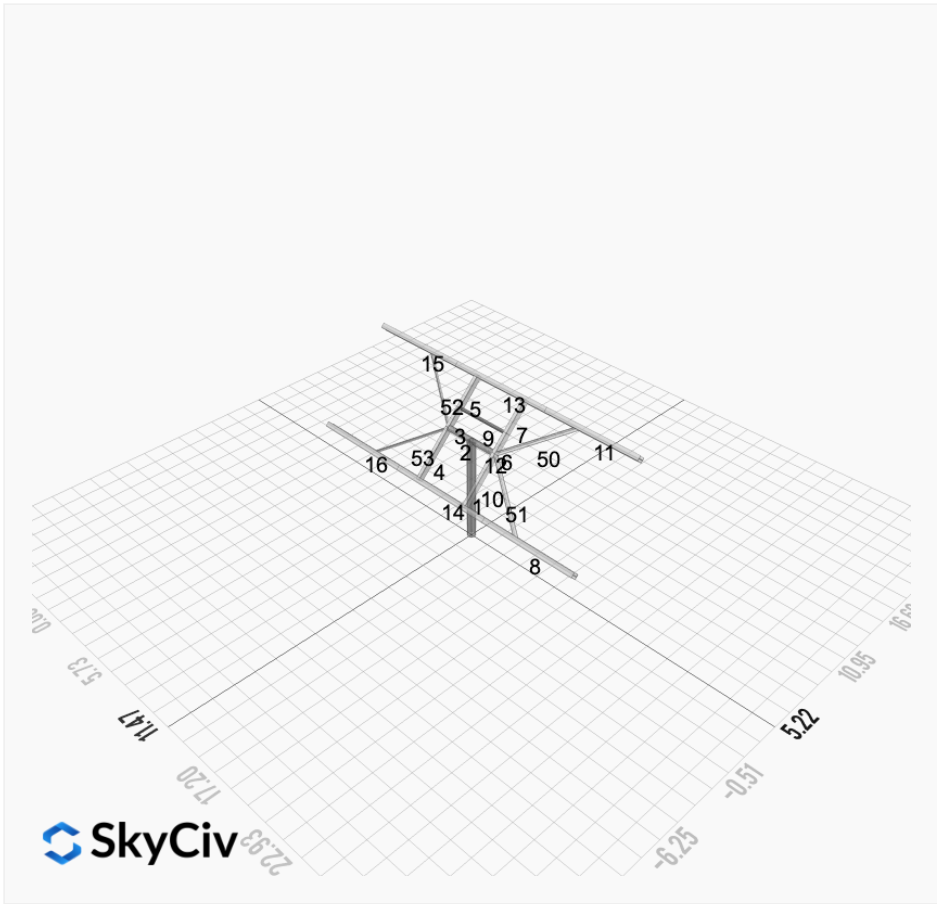

FEM Results (Envelope Worst Case for each member)

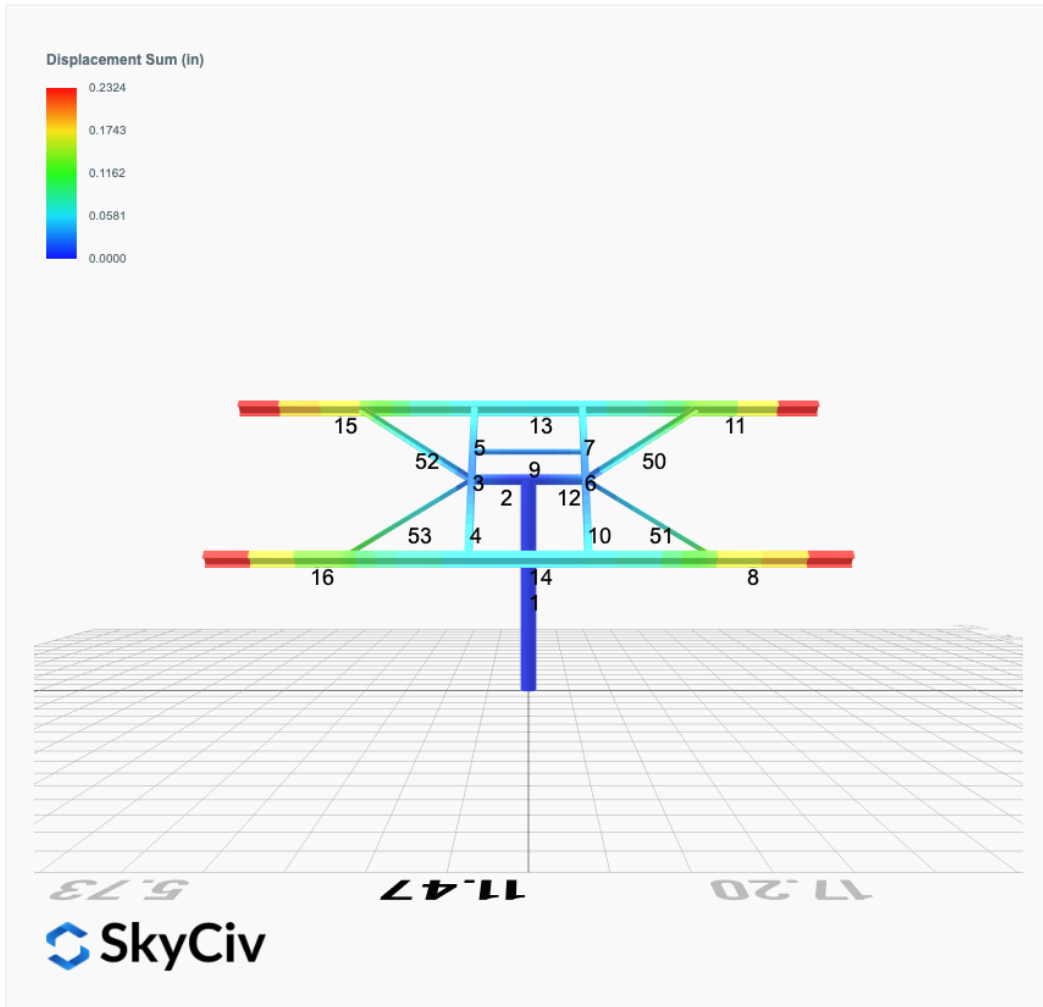

Top Bending Stress Z (ksi)

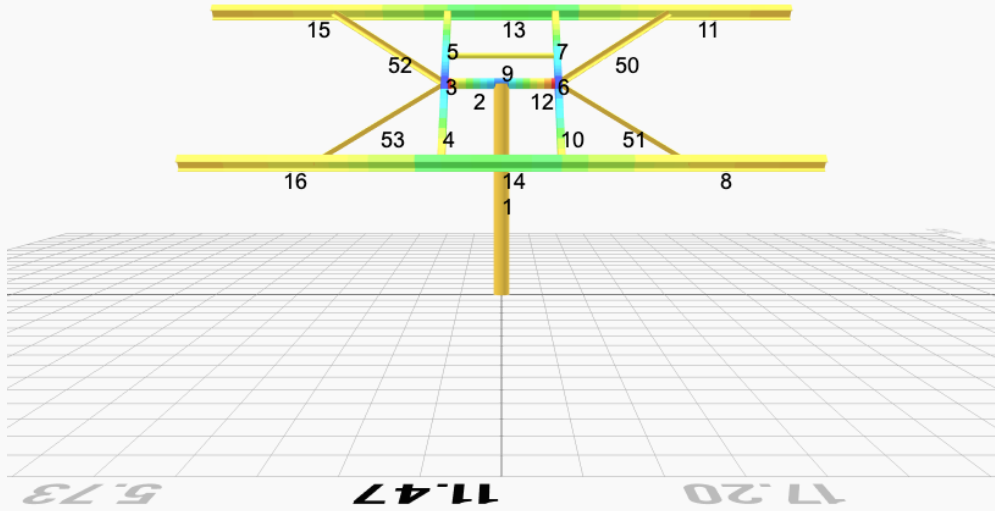
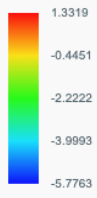

Top Bending Stress Y (ksi)

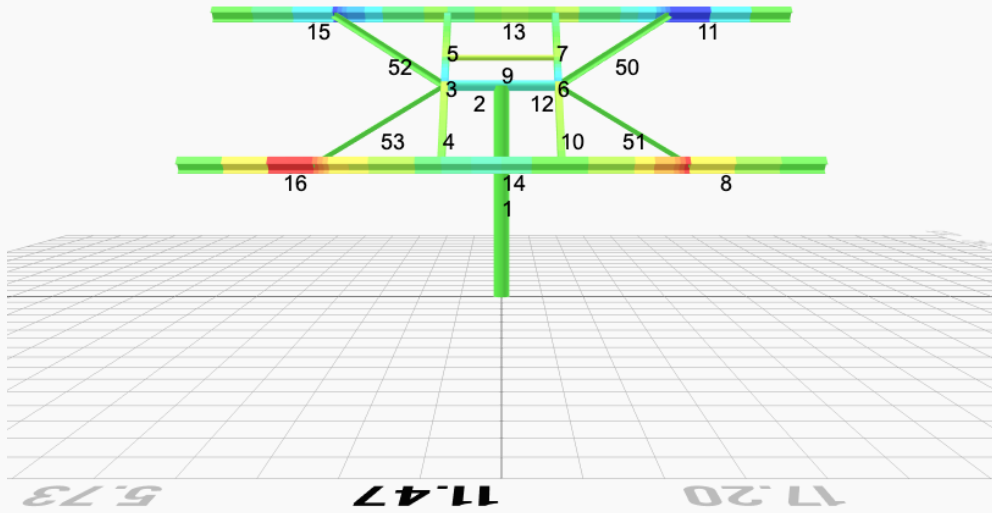

Shear Stress Y (ksi)

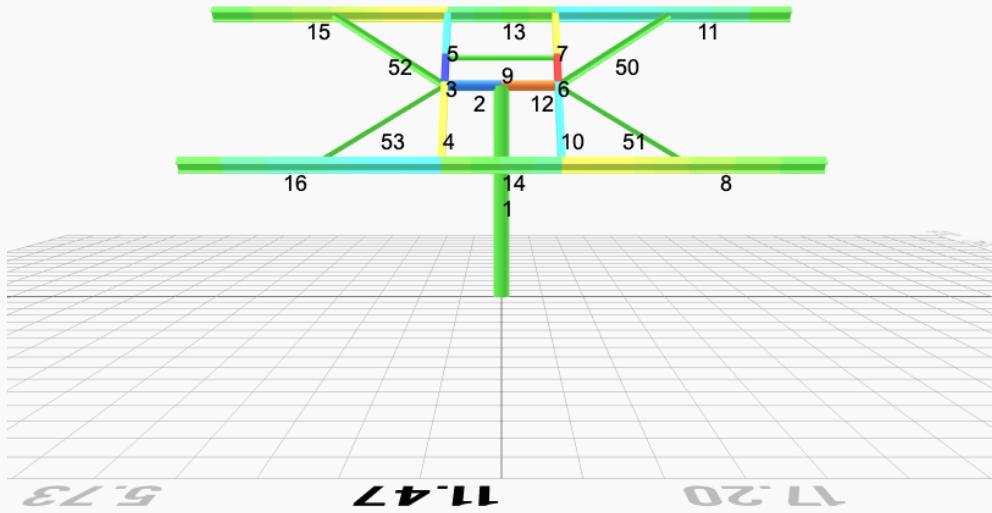

 SkyCiv

Axial Stress (ksi)

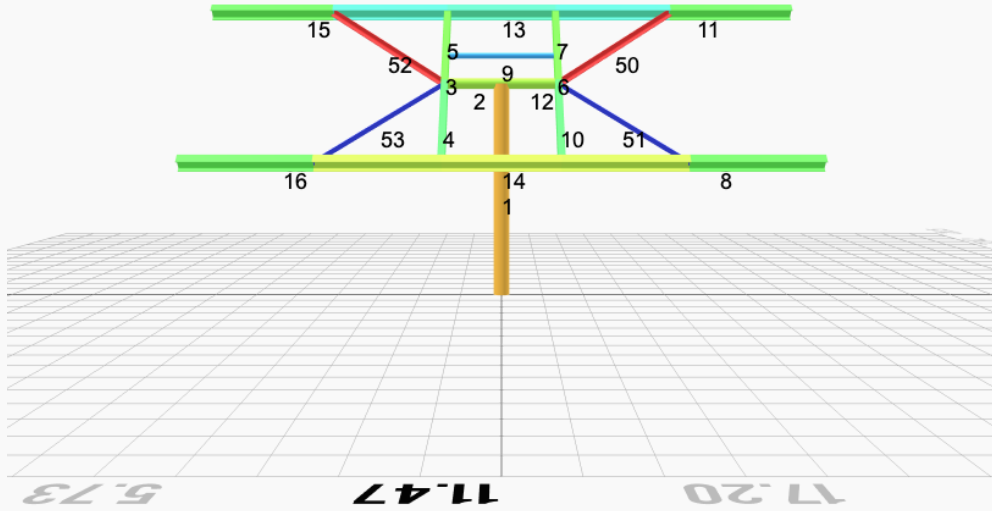
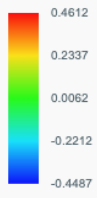

Reaction Forces for Foundation 1 (Node ID#1), (kip, kip-ft)

ASD Load Combination Results

Name	Fx	Fy	Fz	Mx	My	Mz
ULS: 1. D	0.0000	2.3708	0.0000	-0.0000	-0.0000	0.0245
ULS: 2. D + L	0.0000	2.3708	0.0000	-0.0000	-0.0000	0.0245
ULS: 3. D + (S or Lr or R)	0.0000	4.1485	0.0000	-0.0000	-0.0000	0.0358
ULS: 3. D + (S or Lr or R)	0.0000	2.3708	0.0000	-0.0000	-0.0000	0.0245
ULS: 4. D + 0.75L + 0.75(S or Lr or R)	0.0000	3.7041	0.0000	-0.0000	-0.0000	0.0330
ULS: 4. D + 0.75L + 0.75(S or Lr or R)	0.0000	2.3708	0.0000	-0.0000	-0.0000	0.0245
ULS: 5b. D + 0.7E	0.0000	2.3708	0.0000	-0.0000	-0.0000	0.0245
ULS: 6b. D + 0.75L + 0.75(0.7)E + 0.75S	0.0000	3.7041	0.0000	-0.0000	-0.0000	0.0330
ULS: 8. 0.6D + 0.7E	0.0000	1.4225	0.0000	-0.0000	-0.0000	0.0147
ULS: 5a. D + 0.6W_Wind downforce Case A only	-1.8896	4.1955	0.0000	-0.0000	-0.0000	14.1598
ULS: 5a. D + 0.6W_Wind downforce Case B only	0.0000	2.3708	0.0000	-0.0000	-0.0000	0.0245
ULS: 5a. D + 0.6W_Wind uplift Case A only	1.8896	0.5461	0.0000	-0.0000	-0.0000	-13.8360
ULS: 5a. D + 0.6W_Wind uplift Case B only	0.0000	2.3708	0.0000	-0.0000	-0.0000	0.0245
ULS: 6a. D + 0.75L + 0.75(0.6)W + 0.75(S or Lr or R)_Wind downforce Case A only	-1.4172	5.0726	0.0000	-0.0000	-0.0000	10.6345
ULS: 6a. D + 0.75L + 0.75(0.6)W + 0.75(S or Lr or R)_Wind downforce Case B only	0.0000	3.7041	0.0000	-0.0000	-0.0000	0.0330
ULS: 6a. D + 0.75L + 0.75(0.6)W + 0.75(S or Lr or R)_Wind uplift Case A only	1.4172	2.3355	0.0000	-0.0000	-0.0000	-10.3624
ULS: 6a. D + 0.75L + 0.75(0.6)W + 0.75(S or Lr or R)_Wind uplift Case B only	0.0000	3.7041	0.0000	-0.0000	-0.0000	0.0330
ULS: 6a. D + 0.75L + 0.75(0.6)W + 0.75(S or Lr or R)_Wind downforce Case A only	-1.4172	3.7394	0.0000	-0.0000	-0.0000	10.6260
ULS: 6a. D + 0.75L + 0.75(0.6)W + 0.75(S or Lr or R)_Wind downforce Case B only	0.0000	2.3708	0.0000	-0.0000	-0.0000	0.0245
ULS: 6a. D + 0.75L + 0.75(0.6)W + 0.75(S or Lr or R)_Wind uplift Case A only	1.4172	1.0022	0.0000	-0.0000	-0.0000	-10.3708
ULS: 6a. D + 0.75L + 0.75(0.6)W + 0.75(S or Lr or R)_Wind uplift Case B only	0.0000	2.3708	0.0000	-0.0000	-0.0000	0.0245
ULS: 7. 0.6D + 0.6W_Wind downforce Case A only	-1.8896	3.2472	0.0000	-0.0000	-0.0000	14.1500
ULS: 7. 0.6D + 0.6W_Wind downforce Case B only	0.0000	1.4225	0.0000	-0.0000	-0.0000	0.0147
ULS: 7. 0.6D + 0.6W_Wind uplift Case A only	1.8896	-0.4023	0.0000	-0.0000	-0.0000	-13.8458
ULS: 7. 0.6D + 0.6W_Wind uplift Case B only	0.0000	1.4225	0.0000	-0.0000	-0.0000	0.0147

Worst Case Reactions LRFD

These calculations are taken directly from the FEA via SkyCiv and are used in the Concrete Checks of the Foundation Module.

Note: Worst case values are assumed as downforce wind load cases.

Result	Value (kip, kip-ft)
Axial	7.2098
Shear X	-3.1493
Shear Z	0.0000
Moment X	-0.0010
Moment Y (Twist)	0.0005
Moment Z	23.9893

Worst Case Reactions ASD

These results are taken from the worst case values in the above table and are used in the Soil Checks in the Foundation Module.

Note: Worst case values are assumed as downforce wind load cases.

Result	Value (kip, kip-ft)
Axial	5.0726
Shear X	-1.8896
Shear Z	0.0000
Moment X	-0.0000
Moment Y (Twist)	0.0000
Moment Z	14.1598

Project Details

Design Code: AISC 360-16 LRFD
 Provision: LRFD
 Country: United States
 User Name: sales@mtsolar.us
 Unit System: imperial



Design Input Information

Design Factors			
Φ_t	Φ_c	Φ_b	Φ_v
0.9	0.9	0.9	0.9

Design Materials			
ID	E (ksi)	F _y (ksi)	F _u (ksi)
1	29000	50	65

Section Dimensions

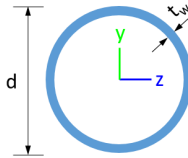

ID	Name	d (in)	t _w (in)				
1	2in Pipe Sch 40	2.38	0.15				
4	4in Pipe Sch 40	4.50	0.24				
7	6in Pipe Sch 40	6.63	0.28				

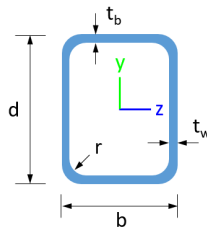

ID	Name	d (in)	b (in)	t _w (in)	t _b (in)	r (in)	
15	HSS5x3x1/8	5.00	3.00	0.12	0.12	0.12	

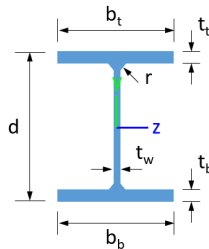

ID	Name	d (in)	t _w (in)	b _t (in)	b _b (in)	t _t (in)	t _b (in)	r (in)
18	W6x9	5.90	0.17	3.94	3.94	0.21	0.21	0.25

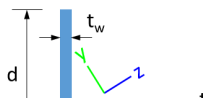

Member Design Capacity

Member ID	$\Phi_t P_n$ (kip)	$\Phi_c P_n$ (kip)	$\Phi_b M_{zn}$ (k-ft)	$\Phi_b M_{yn}$ (k-ft)	$\Phi_v V_{yn}$ (kip)	$\Phi_v V_{zn}$ (kip)
1	251.16	151.54	42.30	42.30	75.35	75.35
2	142.83	141.72	16.17	16.17	42.85	42.85
3	79.65	74.89	10.99	6.26	29.14	16.61
4	79.65	72.84	10.99	6.26	29.14	16.61
5	79.65	74.30	10.99	6.26	29.14	16.61
6	79.65	74.89	10.99	6.26	29.14	16.61
7	79.65	74.30	10.99	6.26	29.14	16.61
8	120.60	64.33	23.36	6.45	30.09	45.74
9	48.35	43.11	2.85	2.85	14.51	14.51
10	79.65	72.84	10.99	6.26	29.14	16.61
11	120.60	64.33	23.36	6.45	30.09	45.74
12	142.83	141.72	16.17	16.17	42.85	42.85
13	120.60	84.03	17.94	6.45	30.09	45.74
14	120.60	84.03	17.93	6.45	30.09	45.74
15	120.60	64.33	23.36	6.45	30.09	45.74
16	120.60	64.33	23.36	6.45	30.09	45.74
50	41.27	8.45	1.63	0.76	15.23	10.15
51	41.27	8.45	1.63	0.76	15.23	10.15
52	41.27	8.45	1.63	0.76	15.23	10.15
53	41.27	8.45	1.63	0.76	15.23	10.15

Design Ratio

Member ID	P	M _z	M _y	V _y	V _z	(P,M _z ,M _y)	Worst LC	KL/r	δ	Status
1	0.048	0.567	0.000	0.042	0.000	0.590	#13	0.416	Not Required	Pass
2	0.006	0.361	0.218	0.082	0.037	0.575	#13	0.052	Not Required	Pass
3	0.002	0.582	0.164	0.059	0.053	0.688	#13	0.044	Not Required	Pass
4	0.002	0.576	0.054	0.058	0.004	0.612	#13	0.078	Not Required	Pass
5	0.002	0.361	0.037	0.058	0.012	0.385	#13	0.073	Not Required	Pass
6	0.002	0.582	0.164	0.059	0.053	0.688	#13	0.044	Not Required	Pass
7	0.002	0.361	0.037	0.058	0.012	0.385	#13	0.073	Not Required	Pass
8	0.014	0.164	0.138	0.036	0.009	0.204	#21	0.464	Not Required	Pass
9	0.022	0.058	0.062	0.001	0.000	0.128	#13	0.132	Not Required	Pass
10	0.002	0.576	0.054	0.058	0.004	0.612	#13	0.078	Not Required	Pass
11	0.008	0.165	0.138	0.037	0.010	0.201	#21	0.309	Not Required	Pass
12	0.006	0.361	0.218	0.082	0.037	0.575	#13	0.052	Not Required	Pass
13	0.008	0.335	0.023	0.046	0.005	0.353	#13	0.177	Not Required	Pass
14	0.012	0.339	0.028	0.045	0.004	0.343	#13	0.265	Not Required	Pass
15	0.008	0.165	0.138	0.037	0.010	0.201	#21	0.309	Not Required	Pass
16	0.014	0.164	0.138	0.036	0.009	0.204	#21	0.309	Not Required	Pass
50	0.150	0.009	0.005	0.002	0.001	0.162	#21	0.783	Not Required	Pass
51	0.030	0.005	0.016	0.001	0.001	0.047	#21	0.522	Not Required	Pass
52	0.150	0.009	0.005	0.002	0.001	0.162	#23	0.783	Not Required	Pass
53	0.030	0.005	0.016	0.001	0.001	0.047	#23	0.522	Not Required	Pass

Definitions

Φ_t Safety factor for tensile

Φ_c	Safety factor for compression
Φ_b	Safety factor for flexure
Φ_v	Safety factor for shear
E	Modulus of elasticity
F_y	Specified minimum yield stress
F_u	Specified minimum tensile strength
A	Cross-sectional area
J	Torsional constant
I_{yp}	Moment of inertia about the Y axes
I_{zp}	Moment of inertia about the Z axes
I_w	Warping constant
S_{yp}	Plastic section modulus about the Y axis
S_{zp}	Plastic section modulus about the Z axis
KL	Effective length
C_b	Buckling modification factor (from all load combinations)
L_b	Length between braced points
LST	Limited slenderness for tension
LSC	Limited slenderness for compression
LD	Limited deflection
P_n	Nominal axial strength (tension/compression)
M_n	Nominal flexural strength (about Z/Y axis)
V_n	Nominal shear strength (along Z/Y axis)
P	Design ratio in case of axial force
M_z	Design ratio in case of bending about Z axis
M_y	Design ratio in case of bending about Y axis
V_y	Design ratio in case of shear along Y axis
V_z	Design ratio in case of shear along Z axis
(P, M_z, M_y)	Design ratio in case of axial force and bending action
KL/r	Design ratio in case of section slenderness
δ	Design ratio in case of member deflection
OK	Capacity is provided
NG	Capacity is not provided

REFERENCES	CALCULATIONS	RESULTS
------------	--------------	---------

SkyCiv Foundation Design

Pile Foundation

Design Information :

Design code : IBC 2021 (International Building Code)
Unit System : Imperial

Pile Input

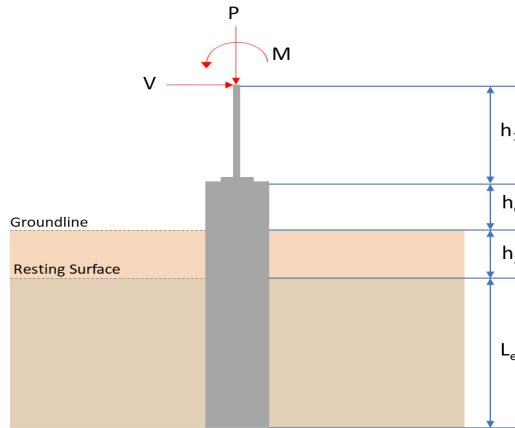

Geometry

Pile shape: rectangular

$b = 60$ in - Pile width

$D = 60$ in - Pile depth

$L = 4.75$ ft - Total pile length

$h_1 = 0$ ft - Lateral load height from the top of the pile,

$h_2 = 0$ ft - Depth to resisting surface

$h_e = 0$ ft - Length of pile above the ground

Tabulation of Soil Parameters

Layer	Label	Allowable Bearing Pressure (q_a) (psf)	Allowable Lateral Pressure (R) (psf/ft)
1	Sand, silty sand, clayey sand, silty gravel & clayey gravel	2000.000	150.000

Tabulation of Loads

Load Component	ASD	LRFD
P (kip)	5.073	7.210
V_x (kip)	-1.890	-3.149
V_z (kip)	0.000	0.000
M_x (kipft)	0.000	-0.001
M_z (kipft)	14.160	23.989

Material Properties

$f'_{ck} = 2.5$ ksi - Concrete strength.

Required depth to resist lateral loads (ASD)

H - Point of application of the lateral load

$$H = h_1 + h_2 + h_e$$

$$H = (0 \text{ ft}) + (0 \text{ ft}) + (0 \text{ ft})$$

$$H = 0 \text{ ft}$$

Considering x-direction:

H_o - Lateral force per length of pile,

$$H_o = \frac{V_x}{1.57 D}$$

$$H_o = \frac{(-1.89 \text{ kip})}{1.57 \times (60 \text{ in})}$$

$$H_o = -0.24076 \text{ kip/ft}$$

M_o - Moment per length of pile,

$$M_o = \frac{M_z + (V_x H)}{1.57 D}$$

$$M_o = \frac{(14.16 \text{ kipft}) + ((-1.89 \text{ kip}) \times (0 \text{ ft}))}{1.57 \times (60 \text{ in})}$$

$$M_o = 1.8038 \text{ kipft/ft}$$

Required depth of embedment in earth:

$$L_x^3 - \left(14.14 \times \frac{H_o \times L_x}{R}\right) - \left(18.85 \times \frac{M_o}{R}\right) = 0$$

Solving the cubic equation:

$L_{e,x} = 4.3381 \text{ ft}$ - Required depth in x-direction,

Considering z-direction:

$L_{e,z} = 0 \text{ ft}$ - Required depth in z-direction,

Minimum embedded depth required:

$L_{e,req}$ - Depth of pile required,

$$L_{e,req} = \text{MAX}[L_{e,x}, L_{e,z}]$$

$$L_{e,req} = \text{MAX}[(4.3381 \text{ ft}), (0 \text{ ft})]$$

$$L_{e,req} = 4.338 \text{ ft}$$

L_e - Actual embedded length of pile,

$$L_e = L - h_e - h_2$$

$$L_e = (4.75 \text{ ft}) - (0 \text{ ft}) - (0 \text{ ft})$$

$$L_e = 4.75 \text{ ft}$$

Ratio - Embedded depth

$$\text{Ratio} = \frac{L_{e,req}}{L_e}$$

$$\text{Ratio} = \frac{(4.338 \text{ ft})}{(4.75 \text{ ft})}$$

$$\text{Ratio} = 0.91326$$

Status: **PASS**
Ratio: **0.910**

End-bearing Capacity (ASD)

A - Pile cross-section area

$$A = b D$$

$$A = (60 \text{ in}) \times (60 \text{ in})$$

$$A = 25 \text{ ft}^2$$

q - End-bearing pressure

$$q = \frac{P_v}{A}$$

$$q = \frac{(5.073 \text{ kip})}{(25 \text{ ft}^2)}$$

$$q = 0.20292 \text{ kip/ft}^2$$

Check bearing capacity ratio:

Ratio - Capacity

$$\text{Ratio} = \frac{q}{q_a}$$

$$\text{Ratio} = \frac{(0.20292 \text{ kip/ft}^2)}{(2000 \text{ psf})}$$

$$\text{Ratio} = 0.10146$$

Status: **PASS**
Ratio: **0.100**

Czerniak

Lateral Soil Pressure (ASD):

L/D - Length to least lateral dimension ratio,

$$L/D = \frac{L}{D}$$

$$L/D = \frac{(4.75 \text{ ft})}{(60 \text{ in})}$$

$$L/D = 0.95$$

Since $L/D \leq 10$,

Pile is short.

Considering x-direction:

$H_o = -0.24076 \text{ kip/ft}$ - Lateral force per length of pile,

$M_o = 1.8038 \text{ kipft/ft}$ - Overturning moment per length of pile,

a - Distance from resting surface to pivot point,

$$a = \frac{(4 M_o L_e) + (3 H_o L_e^2)}{(6 M_o) + (4 H_o L_e)}$$

$$a = \frac{(4 \times (1.8038 \text{ kipft/ft}) \times (4.75 \text{ ft})) + (3 \times (-0.24076 \text{ kip/ft}) \times (4.75 \text{ ft})^2)}{(6 \times (1.8038 \text{ kipft/ft})) + (4 \times (-0.24076 \text{ kip/ft}) \times (4.75 \text{ ft}))}$$

$$a = 3.2843 \text{ ft}$$

p - Earth pressure against the pile at distance $a/2$ from resting surface,

$$p = \frac{0.75 [(4 M_o) + (3 H_o L_e)]^2}{L_e^2 [(3 M_o) + (2 H_o L_e)]}$$

$$p = \frac{0.75 \times [(4 \times (1.8038 \text{ kipft/ft})) + (3 \times (-0.24076 \text{ kip/ft}) \times (4.75 \text{ ft}))]^2}{(4.75 \text{ ft})^2 \times [(3 \times (1.8038 \text{ kipft/ft})) + (2 \times (-0.24076 \text{ kip/ft}) \times (4.75 \text{ ft}))]}$$

$$p = 0.15238 \text{ kip/ft}^2$$

s - Earth pressure against the pile at distance L_e ,

$$s = \frac{6 [(2 M_o) + (H_o L_e)]}{L_e^2}$$

$$s = \frac{6 \times [(2 \times (1.8038 \text{ kipft/ft})) + ((-0.24076 \text{ kip/ft}) \times (4.75 \text{ ft}))]}{(4.75 \text{ ft})^2}$$

$$s = 0.65525 \text{ kip/ft}^2$$

Check lateral soil pressure capacity:

p_a - Allowable lateral soil pressure at depth $a/2$,

$$p_a = R \frac{a}{2}$$

$$p_a = (150 \text{ psf/ft}) \times \frac{(3.2843 \text{ ft})}{2}$$

$$p_a = 0.24632 \text{ kip/ft}^2$$

Ratio - Lateral soil capacity

$$\text{Ratio} = \frac{p}{p_a}$$

$$\text{Ratio} = \frac{(0.15238 \text{ kip/ft}^2)}{(0.24632 \text{ kip/ft}^2)}$$

$$\text{Ratio} = 0.61863$$

p_s - Allowable lateral soil pressure at depth L_e ,

$$p_s = R L_e$$

$$p_s = (150 \text{ psf/ft}) \times (4.75 \text{ ft})$$

$$p_s = 0.7125 \text{ kip/ft}^2$$

Ratio - Lateral soil capacity

$$\text{Ratio} = \frac{s}{p_s}$$

$$\text{Ratio} = \frac{(0.65525 \text{ kip/ft}^2)}{(0.7125 \text{ kip/ft}^2)}$$

Status: **PASS**
Ratio: **0.620**

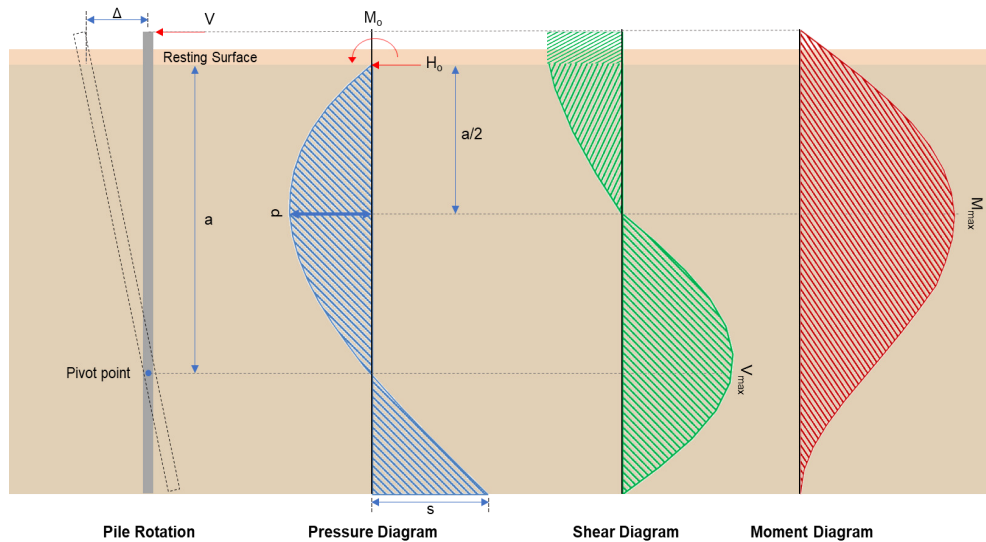
**Shear force and Bending moment (x-direction, LRFD)** H_o - Lateral force per length of pile,

$$H_o = \frac{V_x}{1.57 D}$$

$$H_o = \frac{(-3.149 \text{ kip})}{1.57 \times (60 \text{ in})}$$

$$H_o = -0.40115 \text{ kip/ft}$$

 M_o - Moment per length of pile,

$$M_o = \frac{M_z + (V_x H)}{1.57 D}$$

$$M_o = \frac{(23.989 \text{ kipft}) + ((-3.149 \text{ kip}) \times (0 \text{ ft}))}{1.57 \times (60 \text{ in})}$$

$$M_o = 3.0559 \text{ kipft/ft}$$

 E - Distance from lateral load to resisting surface,

$$E = \frac{M_o}{H_o}$$

$$E = \frac{(3.0559 \text{ kipft/ft})}{(-0.40115 \text{ kip/ft})}$$

$$E = 7.618 \text{ ft}$$

 a - Distance from resting surface to pivot point,

$$a = \frac{(4 M_o L_e) + (3 H_o L_e^2)}{(6 M_o) + (4 H_o L_e)}$$

$$a = \frac{(4 \times (3.0559 \text{ kipft/ft}) \times (4.75 \text{ ft})) + (3 \times (-0.40115 \text{ kip/ft}) \times (4.75 \text{ ft})^2)}{(6 \times (3.0559 \text{ kipft/ft})) + (4 \times (-0.40115 \text{ kip/ft}) \times (4.75 \text{ ft}))}$$

$$a = 3.2829 \text{ ft}$$

 V_{max} - Max shear force located at depth a ,

$$V_{max} = (H_o D) \left[1 - \left[3 \left(\frac{4E}{L_e} + 3 \right) \left(\frac{a}{L_e} \right)^2 \right] + \left[4 \left(\frac{3E}{L_e} + 2 \right) \left(\frac{a}{L_e} \right)^3 \right] \right]$$

$$V_{max} = ((-0.40115 \text{ kip/ft}) \times (60 \text{ in})) \times \left[1 - \left[3 \times \left(\frac{4 \times (7.618 \text{ ft})}{(4.75 \text{ ft})} + 3 \right) \times \left(\frac{(3.2829 \text{ ft})}{(4.75 \text{ ft})} \right)^2 \right] + \left[4 \times \left(\frac{3 \times (7.618 \text{ ft})}{(4.75 \text{ ft})} + 2 \right) \times \left(\frac{(3.2829 \text{ ft})}{(4.75 \text{ ft})} \right)^3 \right] \right]$$

$$V_{max} = 0.0144 \text{ kip}$$

M_{max} - Max bending moment located at depth $a/2$,

$$M_{max} = (H_o D L_e) \left[\left(\frac{E}{L_e} + \frac{a}{2 L_e} \right) - \left[\left(\frac{4E}{L_e} + 3 \right) \left(\frac{a}{2 L_e} \right)^3 + \left[\left(\frac{3E}{L_e} + 2 \right) \left(\frac{a}{2 L_e} \right)^4 \right] \right]$$

$$M_{max} = ((-0.40115 \text{ kip/ft}) \times (60 \text{ in}) \times (4.75 \text{ ft})) \times \left[\left(\frac{(7.618 \text{ ft})}{(4.75 \text{ ft})} + \frac{(3.2829 \text{ ft})}{2 \times (4.75 \text{ ft})} \right) - \left[\left(\frac{4 \times (7.618 \text{ ft})}{(4.75 \text{ ft})} + 3 \right) \times \left(\frac{(3.2829 \text{ ft})}{2 \times (4.75 \text{ ft})} \right)^3 + \left[\left(\frac{3 \times (7.618 \text{ ft})}{(4.75 \text{ ft})} + 2 \right) \times \left(\frac{(3.2829 \text{ ft})}{2 \times (4.75 \text{ ft})} \right)^4 \right] \right]$$

$$M_{max} = 15.796 \text{ kipft}$$

Shear force and Bending moment (z-direction, LRFD)

H_o - Lateral force per length of pile,

$$H_o = \frac{V_z}{1.57 b}$$

$$H_o = \frac{(0 \text{ kip})}{1.57 \times (60 \text{ in})}$$

$$H_o = 0 \text{ kip/ft}$$

M_o - Moment per length of pile,

$$M_o = \frac{M_x + (V_z H)}{1.57 b}$$

$$M_o = \frac{(0.001 \text{ kipft}) + ((0 \text{ kip}) \times (0 \text{ ft}))}{1.57 \times (60 \text{ in})}$$

$$M_o = 0.00012739 \text{ kipft/ft}$$

a - Distance from resting surface to pivot point,

$$a = \frac{(4 M_o L_e) + (3 H_o L_e^2)}{(6 M_o) + (4 H_o L_e)}$$

$$a = \frac{(4 \times (0.00012739 \text{ kipft/ft}) \times (4.75 \text{ ft})) + (3 \times (0 \text{ kip/ft}) \times (4.75 \text{ ft})^2)}{(6 \times (0.00012739 \text{ kipft/ft})) + (4 \times (0 \text{ kip/ft}) \times (4.75 \text{ ft}))}$$

$$a = 3.1667 \text{ ft}$$

V_{max} - Max shear force located at depth a ,

$$V_{max} = 12 \left(\frac{M_o b}{L_e} \right) \left(\frac{a}{L_e} - 1 \right) \left(\frac{a}{L_e} \right)^2$$

$$V_{max} = 12 \times \left(\frac{(0.00012739 \text{ kipft/ft}) \times (60 \text{ in})}{(4.75 \text{ ft})} \right) \times \left(\frac{(3.1667 \text{ ft})}{(4.75 \text{ ft})} - 1 \right) \times \left(\frac{(3.1667 \text{ ft})}{(4.75 \text{ ft})} \right)^2$$

$$V_{max} = 0.00023839 \text{ kip}$$

M_{max} - Max bending moment at depth $a/2$,

$$M_{max} = (M_o b) \left[1 - \left(4 \frac{a}{2 L_e} \right)^3 + \left(3 \frac{a}{2 L_e} \right)^4 \right]$$

$$M_{max} = ((0.00012739 \text{ kipft/ft}) \times (60 \text{ in})) \times \left[1 - \left(4 \times \frac{(3.1667 \text{ ft})}{2 \times (4.75 \text{ ft})} \right)^3 + \left(3 \times \frac{(3.1667 \text{ ft})}{2 \times (4.75 \text{ ft})} \right)^4 \right]$$

$$M_{max} = 0.00056617 \text{ kipft}$$

Minimum Reinforcement Check (LRFD)

Parameters:

$f'_{ck} = 2.5 \text{ ksi}$ - Concrete strength,
 $f_{yk} = 60 \text{ ksi}$ - Longitudinal reinforcement strength,
 $\phi = 0.65$ - Reduction factor for axial strength,
 $\alpha = 0.8$ - Alpha factor for axial strength,
 $A_g = 3600 \text{ in}^2$ - Gross area of concrete,

Longitudinal reinforcement:

Required reinforcement due to axial load, $A_{st,required}$

$A_{st,required}$

Table 22.4.2.1

22.4.2.2, 10.6.1.1

$$A_{st,required} = Min \left[\frac{\frac{V'}{\phi \alpha} - (0.85 f'_{ck} A_g)}{f_{yk} - (0.85 f'_{ck})}, (0.08 A_g) \right]$$

$$A_{st,required} = Min \left[\frac{\frac{(7.21 \text{ kip})}{(0.65) \times (0.8)} - (0.85 \times (2.5 \text{ ksi}) \times (3600 \text{ in}^2))}{(60 \text{ ksi}) - (0.85 \times (2.5 \text{ ksi}))}, (0.08 \times (3600 \text{ in}^2)) \right]$$

$$A_{st,required} = -131.94 \text{ in}^2$$

A_{min} - Governing minimum reinforcement area,

$$A_{min} = Max [A_{st,required}, (0.0018 A_g)]$$

$$A_{min} = Max [(-131.94 \text{ in}^2), (0.0018 \times (3600 \text{ in}^2))]$$

$$A_{min} = 6.48 \text{ in}^2$$

n_{rebar} - Required number of reinforcement,

$$n_{rebar} = \frac{A_{min}}{A_{rebar}}$$

$$n_{rebar} = \frac{(6.48 \text{ in}^2)}{(0.3068 \text{ in}^2)}$$

$$n_{rebar} = 22$$

A_{st} - Actual total reinforcement area,

$$A_{st} = n_{rebar} \frac{\pi d_{bar}^2}{4}$$

$$A_{st} = (22) \times \frac{\pi \times (0.625 \text{ in})^2}{4}$$

$$A_{st} = 6.7495 \text{ in}^2$$

Ratio - Capacity

$$Ratio = \frac{A_{min}}{A_{st}}$$

$$Ratio = \frac{(6.48 \text{ in}^2)}{(6.7495 \text{ in}^2)}$$

$$Ratio = 0.96007$$

Status: **PASS**
Ratio: **0.960**

25.2.3 s_{rebar} - Minimum spacing of reinforcement,

$$s_{rebar} = Max [1.5, (1.5 d_{bar})]$$

$$s_{rebar} = Max [1.5, (1.5 \times (0.625 \text{ in}))]$$

$$s_{rebar} = 1.5 \text{ in}$$

Ties:

25.7.2.2 Since longitudinal reinforcement is \leq No. 10 \emptyset : Use #3(0.375 in)

25.7.2.1 s_{ties} - Maximum spacing of ties,

$$s_{ties} = Min [(16 d_{bar}), (48 d_{ties}), Min (D, b)]$$

$$s_{ties} = Min [(16 \times (0.625 \text{ in})), (48 \times (0.375 \text{ in})), Min ((60 \text{ in}), (60 \text{ in}))]$$

$$s_{ties} = 10 \text{ in}$$

Summary:

Main reinforcement: **22 - #5 (0.625 in)**

Ties: **#3(0.375 in) - 10 in**

22.4.2.2 **Axial Compression Strength (ACI 318-19, LFRD)**

ϕP_N - Allowable axial compressive strength

$$\phi P_N = \phi 0.80 [(0.85 f'_{ck} [A_g - A_{st}]) + (f_{yk} A_{st})]$$

$$\phi P_N = (0.65) \times 0.80 \times [(0.85 \times (2.5 \text{ ksi}) \times [(3600 \text{ in}^2) - (6.7495 \text{ in}^2)]) + ((60 \text{ ksi}) \times (6.7495 \text{ in}^2))]$$

$$\phi P_N = 4181.1 \text{ kip}$$

Ratio - Capacity

$$Ratio = \frac{P}{\phi P_N}$$

$$Ratio = \frac{(7.21 \text{ kip})}{(4181.1 \text{ kip})}$$

$$Ratio = 0.0017244$$

Status: **PASS**
Ratio: **0.000**

Shear Strength (ACI 318-19, LFRD)

Parameters:

22.5.2.2 b_w = 60 in - Effective width,
 d - Effective depth

$$d = 0.80 D$$

$$d = 0.80 \times (60 \text{ in})$$

$$d = 48 \text{ in}$$

22.5.5.1.3 λ_s - size effect modification factor

$$\lambda_s = MIN \left[\sqrt{\frac{2}{1 + \frac{d}{10}}}, 1 \right]$$

$$\lambda_s = MIN \left[\sqrt{\frac{2}{1 + \frac{(48 \text{ in})}{10}}}, 1 \right]$$

$$\lambda_s = 0.58722$$

22.5.5.1.1 The following variables were converted to be consistent with empirical formula $f'_{ck} = 2.5 \text{ ksi} \rightarrow 2500 \text{ psi}$,
 $V_{c,max}$ - Max shear strength of concrete

$$V_{c,max} = 5 \lambda_s \sqrt{f'_{ck}} b_w d$$

$$V_{c,max} = 5 \times (0.58722) \times \sqrt{(2500 \text{ psi})} \times (60 \text{ in}) \times (48 \text{ in})$$

$$V_{c,max} = 422.8 \text{ kip}$$

22.5.5.1.1(a) The following variables were converted to be consistent with empirical formula $f'_{ck} = 2.5 \text{ ksi} \rightarrow 2500 \text{ psi}$, $P = 7.21 \text{ kip} \rightarrow 7210 \text{ lbf}$,
 $V_{c,a}$ - Shear strength of concrete (a)

$$V_{c,a} = \left[2 \lambda_s \sqrt{f'_{ck}} + \frac{P}{6 A_g} \right] b_w d$$

$$V_{c,a} = \left[2 \times (0.58722) \times \sqrt{(2500 \text{ psi})} + \frac{(7210 \text{ lbf})}{6 \times (3600 \text{ in}^2)} \right] \times (60 \text{ in}) \times (48 \text{ in})$$

$$V_{c,a} = 170.08 \text{ kip}$$

22.5.5.1.2 The following variables were converted to be consistent with empirical formula $f'_{ck} = 2.5 \text{ ksi} \rightarrow 2500 \text{ psi}$,
 $V_{c,b}$ - Shear strength of concrete (b)

$$V_{c,b} = \left[2 \lambda_s \sqrt{f'_{ck}} + (0.05 f'_{ck}) \right] b_w d$$

$$V_{c,b} = \left[2 \times (0.58722) \times \sqrt{(2500 \text{ psi})} + (0.05 \times (2500 \text{ psi})) \right] \times (60 \text{ in}) \times (48 \text{ in})$$

$$V_{c,b} = 529.12 \text{ kip}$$

V_c - Governing shear strength of concrete

$$V_c = MIN [V_{c,max}, V_{c,a}, V_{c,b}]$$

$$V_c = MIN [(422.8 \text{ kip}), (170.08 \text{ kip}), (529.12 \text{ kip})]$$

$$V_c = 170.08 \text{ kip}$$

22.5.1.2 The following variables were converted to be consistent with empirical formula $f'_{ck} = 2.5 \text{ ksi} \rightarrow 2500 \text{ psi}$,
 $V_{s,a}$ - Shear strength of steel (a)

$$V_{s,a} = 8 \sqrt{f'_{ck}} b_w d$$

$$V_{s,a} = 8 \times \sqrt{(2500 \text{ psi})} \times (60 \text{ in}) \times (48 \text{ in})$$

	<p style="text-align: center;">$V_{s,a} = 1152 \text{ kip}$</p> <p>$A_v$ - Ties rebar area,</p> $A_v = \frac{\pi d_{ties}^2}{4}$ $A_v = \frac{\pi \times (0.375 \text{ in})^2}{4}$ $A_v = 0.11045 \text{ in}^2$ <p>22.5.8.5.3 $V_{s,b}$ - Shear strength of steel (b)</p> $V_{s,b} = \frac{2 A_v f_{yw} d}{s_{ties}}$ $V_{s,b} = \frac{2 \times (0.11045 \text{ in}^2) \times (60 \text{ ksi}) \times (48 \text{ in})}{(10 \text{ in})}$ $V_{s,b} = 63.617 \text{ kip}$ <p>V_s - Governing shear strength of steel</p> $V_s = MIN[V_{s,a}, V_{s,b}]$ $V_s = MIN[(1152 \text{ kip}), (63.617 \text{ kip})]$ $V_s = 63.617 \text{ kip}$ <p>22.5.1.1 ϕV_n - Allowable shear strength</p> $\phi V_n = \phi (V_c + V_s)$ $\phi V_n = (0.65) \times ((170.08 \text{ kip}) + (63.617 \text{ kip}))$ $\phi V_n = 151.9 \text{ kip}$ <p>Considering x-direction:</p> <p>$V_{max} = 7.0147 \text{ kip}$ - Maximum shear force in the x-direction, Ratio - Capacity</p> $Ratio = \frac{V_{max}}{\phi V_n}$ $Ratio = \frac{(7.0147 \text{ kip})}{(151.9 \text{ kip})}$ $Ratio = 0.046178$	<p>Status: PASS Ratio: 0.050</p>
<p>14.5.2.1b</p>	<p>Flexural Strength (ACI 318-19, LRFD)</p> <p>S_m - Section modulus</p> $S_m = \frac{b D^2}{6}$ $S_m = \frac{(60 \text{ in}) \times (60 \text{ in})^2}{6}$ $S_m = 36000 \text{ in}^3$ <p>$\lambda = 1$ - Concrete modification factor (Normal concrete), Allowable flexural strength: M_n shall be the lesser of: $\phi M_{n,1}$</p> $\phi M_{n,1} = \phi \times 5 \times \lambda \times \sqrt{f'_c} \times S_m$ $\phi M_{n,1} = 0.65 \times 5 \times 1 \times \sqrt{(2.5 \text{ ksi})} \times 35999.999 \text{ in}^3$ $\phi M_{n,1} = 487.500 \text{ kipft}$ <p>$\phi M_{n,2}$</p> $\phi M_{n,2} = \phi \times 0.85 f'_c S_m$ $\phi M_{n,2} = (0.65) \times 0.85 \times (2.5 \text{ ksi}) \times (36000 \text{ in}^3)$ $\phi M_{n,2} = 4143.7 \text{ kipft}$	

Therefore,
 ϕM_n - Allowable flexural strength,

$$\phi M_n = \text{MIN}[\phi M_{n,1}, \phi M_{n,2}]$$

$$\phi M_n = \text{MIN}[(487.5 \text{ kipft}), (4143.7 \text{ kipft})]$$

$$\phi M_n = 487.5 \text{ kipft}$$

Considering x-direction:

$M_{max} = 15.796 \text{ kipft}$ - Maximum moment in the x-direction,

Ratio - Capacity

$$\text{Ratio} = \frac{M_{max}}{\phi M_n}$$

$$\text{Ratio} = \frac{(15.796 \text{ kipft})}{(487.5 \text{ kipft})}$$

$$\text{Ratio} = 0.032401$$

Status: **PASS**
Ratio: **0.030**

Considering z-direction:

$M_{max} = 0.00056617 \text{ kipft}$ - Maximum moment in the z-direction,

Ratio - Capacity

$$\text{Ratio} = \frac{M_{max}}{\phi M_n}$$

$$\text{Ratio} = \frac{(0.00056617 \text{ kipft})}{(487.5 \text{ kipft})}$$

$$\text{Ratio} = 1.1614 \times 10^{-6}$$

Status: **PASS**
Ratio: **0.000**