

Your Project Calculations



Project Name: Colorado Energy_TOP-8-Mission

S3D Model Link:
https://platform.skyciv.com/structural?preload_name=Colorado%20Energy_TOP-8-Mission&preload_path=Shared%20Enterprise%20Folder/MT_Solar_Projects/6_2023

Public Model Link:
https://platform.skyciv.com/structural-viewer?project_id=rOm1pUrpdahTkvmzoOrajoeeqXQFJZF8IQxxFsq4sKEn4zHyOYDTFCKlrxjzdNh

Array Specification

Product:	Beam
Unique ID:	1P-0-6TOP-SD-24-L-4Hx2W-9K8K
Duty Classification:	SD
Module Width:	41.50 in
Module Length:	68.80in
Number of Rows:	4
Number of Columns:	2
Total Number of Modules:	8
Desired Tilt Angle:	55
Front Edge Clearance:	5
Total Array Height at Tilt:	16.40 ft
Total Frame Length:	11.50 ft
Frame Weight:	562 lbs
Array Dimensions N/S:	14.00 ft
Array Dimensions E/W:	11.63 ft
Rail Length:	168.00 in
Rail Spacing:	2.87 ft
Rail Check:	Not Checked

Support Specifications

Pole Size:	6in Pipe Sch 40
Pole Length above Grade:	10.73 ft
Number of Poles:	1
Pole Spacing:	0

Foundation Specifications

Foundation Type:	Square
Foundation Dimensions:	48 x 48 in
Foundation Depth (below grade):	Pile 1: 3.00 ft
Foundation Volume:	1.778 y ³
Foundation Result:	PASSED
Mount Twist:	0.000000 kip

Site Info

Risk Category:	I
Exposure:	C
Soil Classification:	sand
Site Location:	1140 Devereux Rd, Glenwood Springs, CO 81601, USA
Wind Speed:	99 mph
Snow Load:	40 psf
Design Uplift Pressure:	0.000000 ksf
Design Downforce Pressure:	0.000000 ksf
Design Snow Pressure:	0.006598 ksf



Design Disclaimer

This software should be used for preliminary designs and should not be used as a final design unless reviewed, verified and designed by a qualified structural engineer.

AutoDesigner Input

```
{
  "wind_speed_override": null,
  "snow_load_override": null,
  "direct_snow_load": false,
  "product_type": "Beam",
  "project_id": "Colorado Energy_TOP-8-Mission",
  "site_address": "1140 Devereux Rd, Glenwood Springs, CO 81601, USA",
  "module_width": 41.5,
  "module_length": 68.8,
  "number_rows": 4,
  "number_columns": 2,
  "pole_mount_section": "4_40",
  "core_pipe_width": 65,
  "core_pipe_section": "2_40",
  "adjuster_section": "2_40",
  "core_beam_height": 65,
  "core_beam_section": "HSS3x2x1/8",
  "main_pipe_section": "2_12GA",
  "pole_spacing": 15,
  "tilt_angle": 55,
  "ground_clearance": 5,
  "risk_category": "I",
  "exposure_category": "C",
  "frame_duty_override": "auto",
  "pole_override": "auto",
  "soil_type": "sand",
  "foundation_type": "Square",
  "foundation_size": 48,
  "check_rails": false
}
```

Design Notes:

- AISC Deflection checks are set to L/1 due to structure design intent
- Foundation Design and Sizing is approximate only

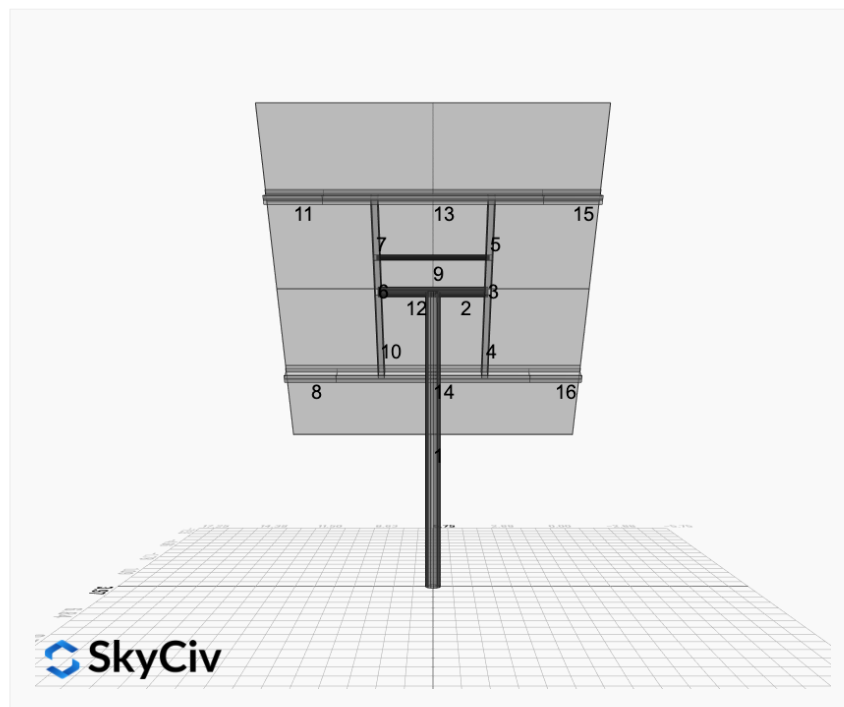

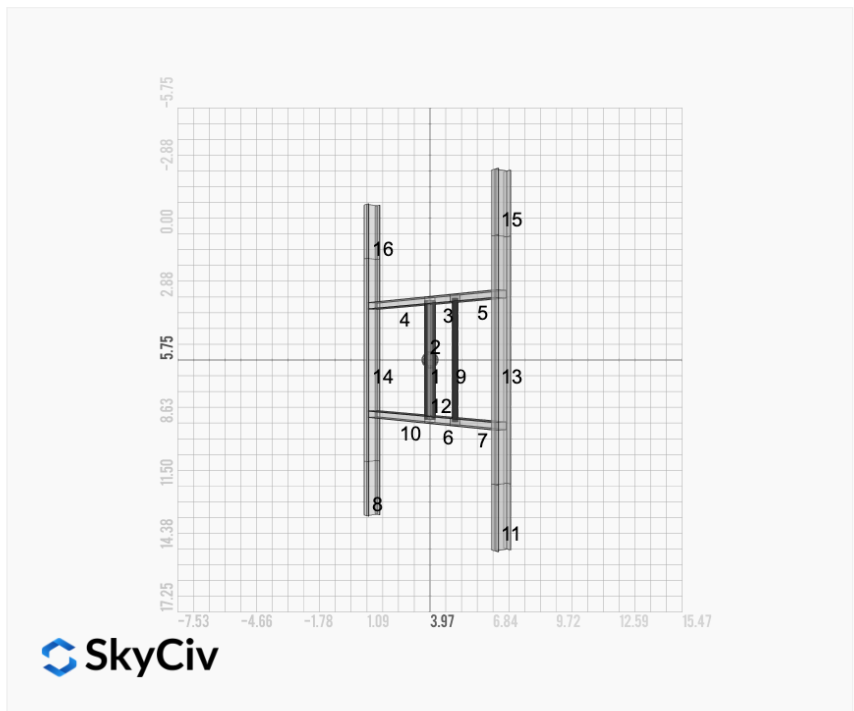
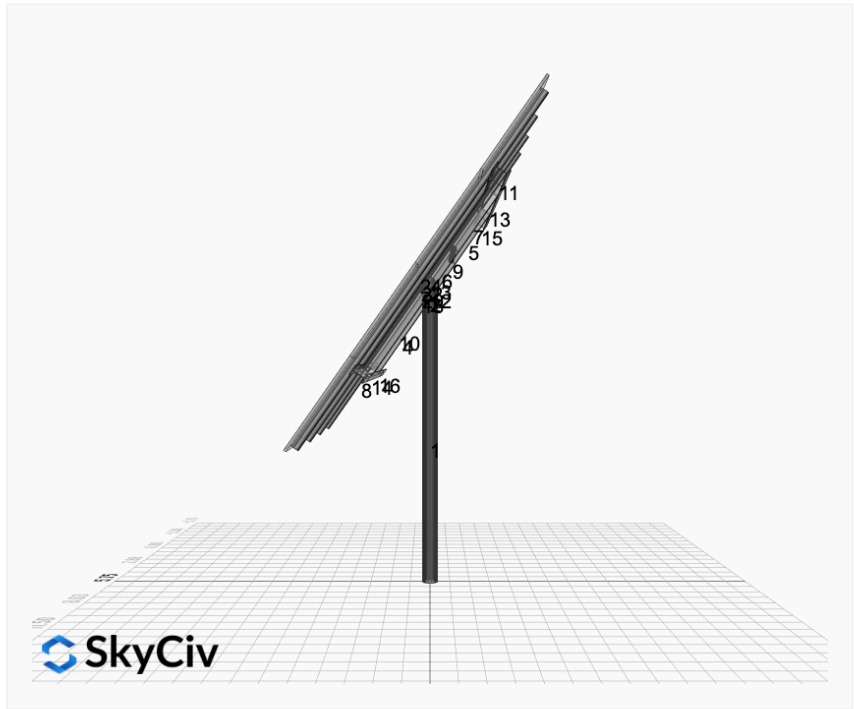

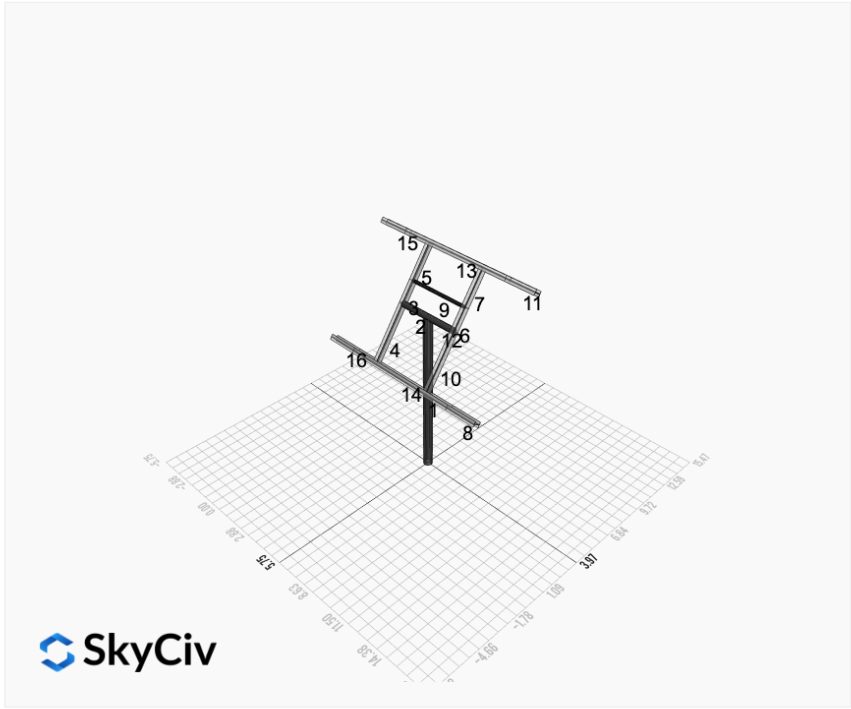

FEM Results (Envelope Worst Case for each member)

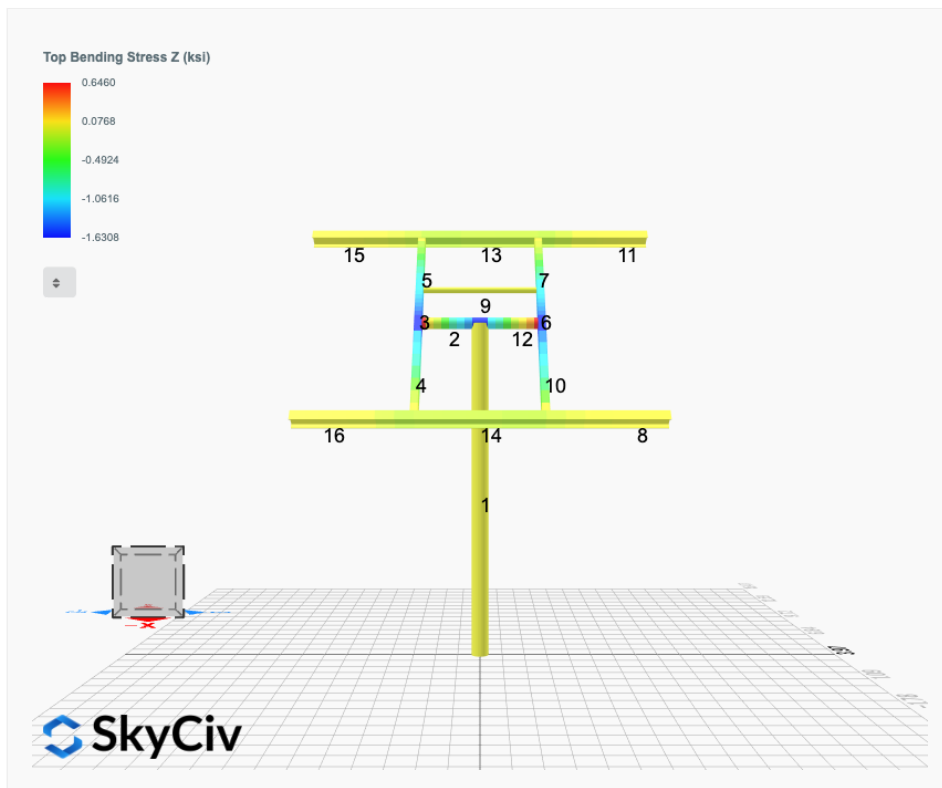
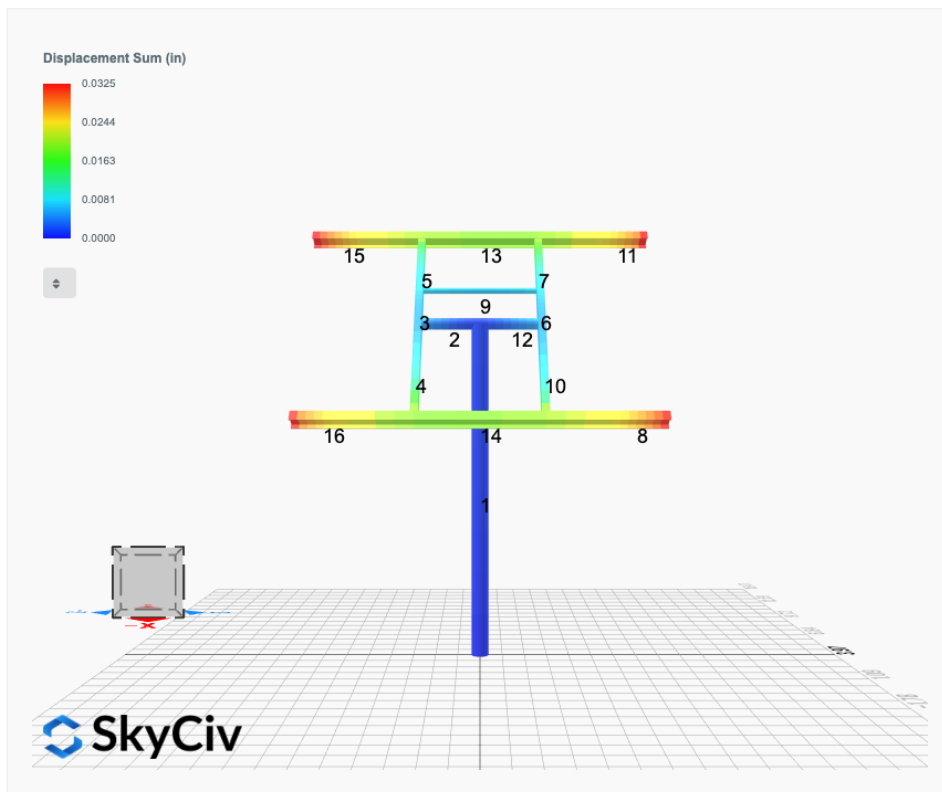

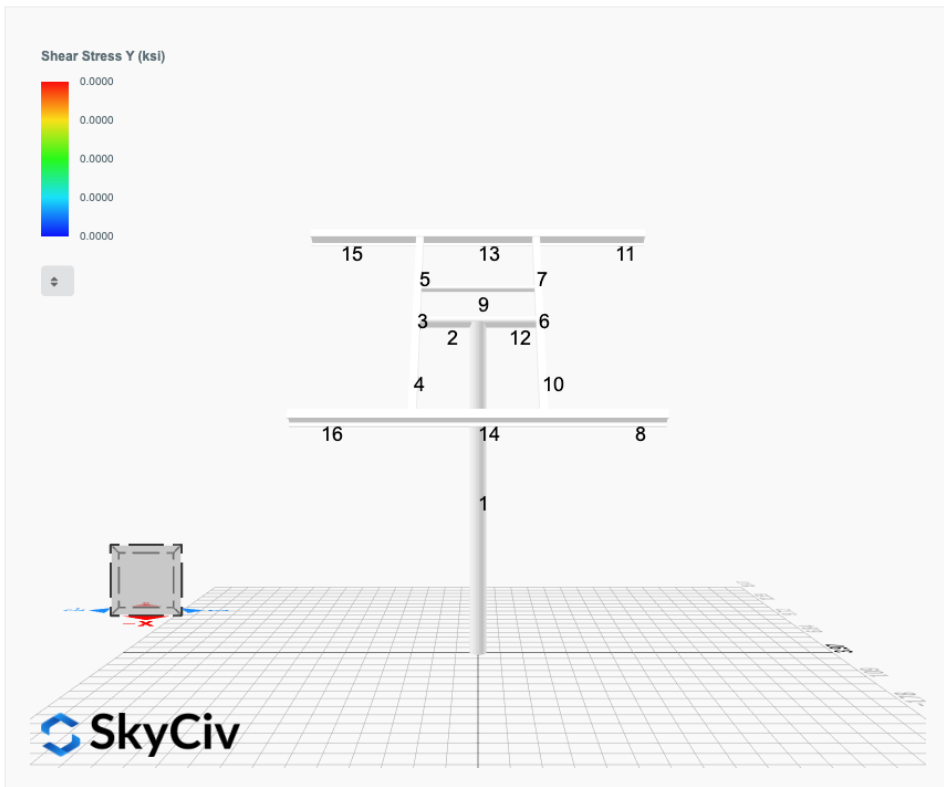
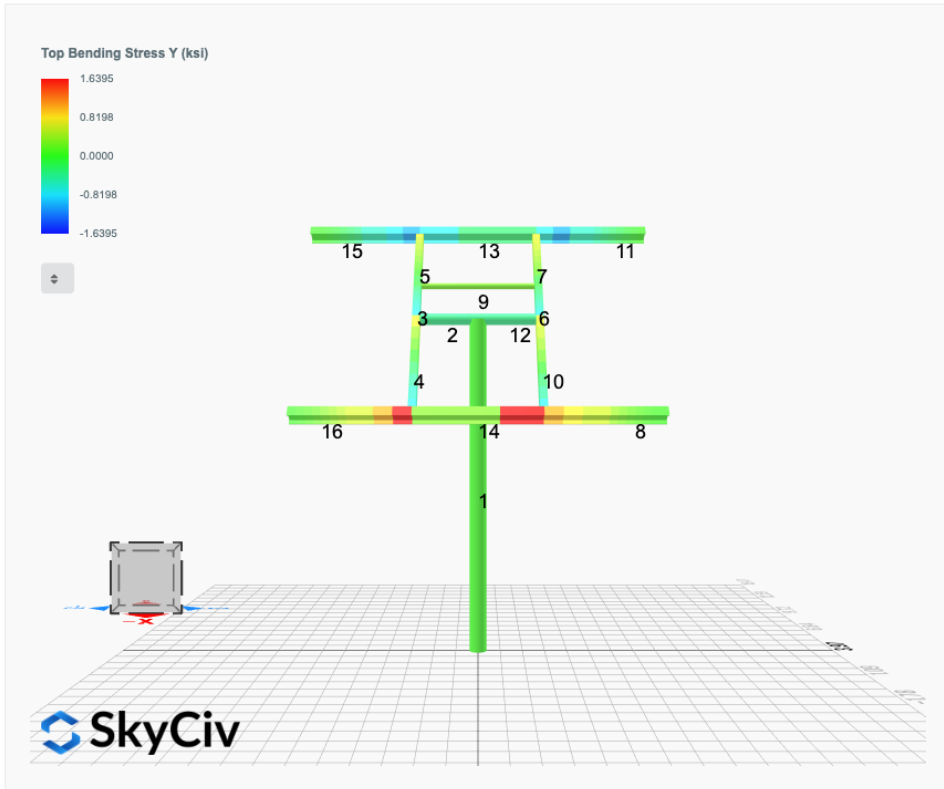

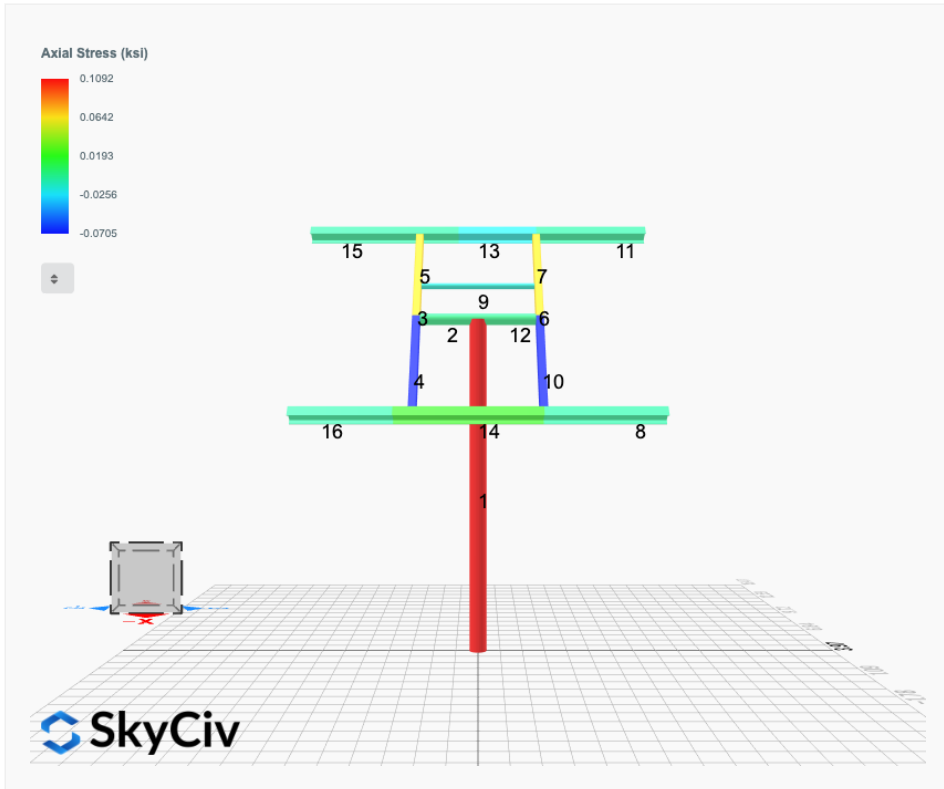

Reaction Forces for Foundation 1 (Node ID#1), (kip, kip-ft)

ASD Load Combination Results

Name	Fx	Fy	Fz	Mx	My	Mz
ULS: 1. D	-0.0000	1.3332	0.0000	0.0000	-0.0000	0.0131
ULS: 2. D + L	-0.0000	1.3332	0.0000	0.0000	-0.0000	0.0131
ULS: 3. D + (S or Lr or R)	-0.0000	1.9425	-0.0000	0.0000	-0.0000	0.0137
ULS: 3. D + (S or Lr or R)	-0.0000	1.3332	0.0000	0.0000	-0.0000	0.0131
ULS: 4. D + 0.75L + 0.75(S or Lr or R)	-0.0000	1.7902	-0.0000	0.0000	-0.0000	0.0136
ULS: 4. D + 0.75L + 0.75(S or Lr or R)	-0.0000	1.3332	0.0000	0.0000	-0.0000	0.0131
ULS: 5b. D + 0.7E	-0.0000	1.3332	0.0000	0.0000	-0.0000	0.0131
ULS: 6b. D + 0.75L + 0.75(0.7)E + 0.75S	-0.0000	1.7902	-0.0000	0.0000	-0.0000	0.0136
ULS: 8. 0.6D + 0.7E	-0.0000	0.7999	0.0000	0.0000	-0.0000	0.0078
ULS: 5a. D + 0.6W_Wind downforce Case A only	-0.0000	1.3332	0.0000	0.0000	-0.0000	0.0131
ULS: 5a. D + 0.6W_Wind downforce Case B only	-0.0000	1.3332	0.0000	0.0000	-0.0000	0.0131
ULS: 5a. D + 0.6W_Wind uplift Case A only	-0.0000	1.3332	0.0000	0.0000	-0.0000	0.0131
ULS: 5a. D + 0.6W_Wind uplift Case B only	-0.0000	1.3332	0.0000	0.0000	-0.0000	0.0131
ULS: 6a. D + 0.75L + 0.75(0.6)W + 0.75(S or Lr or R)_Wind downforce Case A only	-0.0000	1.7902	-0.0000	0.0000	-0.0000	0.0136
ULS: 6a. D + 0.75L + 0.75(0.6)W + 0.75(S or Lr or R)_Wind downforce Case B only	-0.0000	1.7902	-0.0000	0.0000	-0.0000	0.0136
ULS: 6a. D + 0.75L + 0.75(0.6)W + 0.75(S or Lr or R)_Wind uplift Case A only	-0.0000	1.7902	-0.0000	0.0000	-0.0000	0.0136
ULS: 6a. D + 0.75L + 0.75(0.6)W + 0.75(S or Lr or R)_Wind uplift Case B only	-0.0000	1.7902	-0.0000	0.0000	-0.0000	0.0136
ULS: 6a. D + 0.75L + 0.75(0.6)W + 0.75(S or Lr or R)_Wind downforce Case A only	-0.0000	1.3332	0.0000	0.0000	-0.0000	0.0131
ULS: 6a. D + 0.75L + 0.75(0.6)W + 0.75(S or Lr or R)_Wind downforce Case B only	-0.0000	1.3332	0.0000	0.0000	-0.0000	0.0131
ULS: 6a. D + 0.75L + 0.75(0.6)W + 0.75(S or Lr or R)_Wind uplift Case A only	-0.0000	1.3332	0.0000	0.0000	-0.0000	0.0131
ULS: 6a. D + 0.75L + 0.75(0.6)W + 0.75(S or Lr or R)_Wind uplift Case B only	-0.0000	1.3332	0.0000	0.0000	-0.0000	0.0131
ULS: 7. 0.6D + 0.6W_Wind downforce Case A only	-0.0000	0.7999	0.0000	0.0000	-0.0000	0.0078
ULS: 7. 0.6D + 0.6W_Wind downforce Case B only	-0.0000	0.7999	0.0000	0.0000	-0.0000	0.0078
ULS: 7. 0.6D + 0.6W_Wind uplift Case A only	-0.0000	0.7999	0.0000	0.0000	-0.0000	0.0078
ULS: 7. 0.6D + 0.6W_Wind uplift Case B only	-0.0000	0.7999	0.0000	0.0000	-0.0000	0.0078

Worst Case Reactions LRFD

These calculations are taken directly from the FEA via SkyCiv and are used in the Concrete Checks of the Foundation Module.
Note: Worst case values are assumed as downforce wind load cases.

Result	Value (kip, kip-ft)
Axial	2.5747
Shear X	-0.0000
Shear Z	-0.0000
Moment X	0.0000
Moment Y (Twist)	0.0000
Moment Z	0.0231

Worst Case Reactions ASD

These results are taken from the worst case values in the above table and are used in the Soil Checks in the Foundation Module.
Note: Worst case values are assumed as downforce wind load cases.

Result	Value (kip, kip-ft)
Axial	1.9425
Shear X	-0.0000
Shear Z	-0.0000
Moment X	0.0000
Moment Y (Twist)	0.0000
Moment Z	0.0137

Project Details

Design Code: AISC 360-16 LRFD
 Provision: LRFD
 Country: United States
 User Name: sales@mtsolar.us
 Unit System: imperial



Design Input Information

Design Factors			
Φ_t	Φ_c	Φ_b	Φ_v
0.9	0.9	0.9	0.9

Design Materials			
ID	E (ksi)	F_y (ksi)	F_u (ksi)
1	29000	50	65

Section Dimensions



ID	Name	d (in)	t_w (in)				
1	2in Pipe Sch 40	2.38	0.15				
4	4in Pipe Sch 40	4.50	0.24				
7	6in Pipe Sch 40	6.63	0.28				



ID	Name	d (in)	b (in)	t_w (in)	t_b (in)	r (in)	
15	HSS5x3x1/8	5.00	3.00	0.12	0.12	0.12	



ID	Name	d (in)	t_w (in)	b_t (in)	b_b (in)	t_t (in)	t_b (in)	r (in)
18	W6x9	5.90	0.17	3.94	3.94	0.21	0.21	0.25

Section Properties

ID	Name	A (in ²)	J (in ⁴)	I_{yp} (in ⁴)	I_{zp} (in ⁴)	I_w (in ⁶)	S_{yp} (in ³)	S_{zp} (in ³)
1	2in Pipe Sch 40	1.07	1.33	0.67	0.67	0.00	0.76	0.76
4	4in Pipe Sch 40	3.17	14.47	7.23	7.23	0.00	4.31	4.31
7	6in Pipe Sch 40	5.58	56.28	28.14	28.14	0.00	11.28	11.28

15	HSS5x3x1/8	1.77	6.02	2.75	6.03	152.35	2.07	2.93
18	W6x9	2.68	0.04	2.20	16.40	17.70	1.72	6.23

Member Properties										
Member ID	Section ID	K _z L (ft)	K _y L (ft)	L _b (ft)	C _b	L	S	T	L	D
1	7	22.54	22.54	10.73	-	3	0	0	2	0
2	4	1.30	1.30	2.00	-	3	0	0	2	0
3	15	0.92	0.92	1.42	1.19,1.19,1.19,1.18,1.19,1.19,1.19,1.19,1.19,1.19,1.19,1.19,1.19,1.19,1.18,1.18,1.18,1.18,1.19,1.19,1.19,1.19,1.19,1.19,1.19	3	0	0	2	0
4	15	2.44	2.44	3.75	1.69,1.68,1.69,1.68,1.69,1.69,1.68,1.68,1.68,1.68,1.69,1.69,1.69,1.68,1.68,1.68,1.69,1.69,1.69,1.69,1.69,1.69,1.69	3	0	0	2	0
5	15	1.52	1.52	2.33	1.68,1.68,1.68,1.67,1.68,1.68,1.68,1.68,1.68,1.68,1.68,1.68,1.68,1.67,1.67,1.67,1.67,1.68,1.68,1.68,1.68,1.68,1.68	3	0	0	2	0
6	15	0.92	0.92	1.42	1.19,1.19,1.19,1.18,1.19,1.19,1.19,1.19,1.19,1.19,1.19,1.19,1.19,1.19,1.18,1.18,1.18,1.18,1.19,1.19,1.19,1.19,1.19,1.19	3	0	0	2	0
7	15	1.52	1.52	2.33	1.68,1.68,1.68,1.67,1.68,1.68,1.68,1.68,1.68,1.68,1.68,1.68,1.68,1.67,1.67,1.67,1.67,1.68,1.68,1.68,1.68,1.68,1.68	3	0	0	2	0
8	18	4.20	4.20	2.00	2.33,2.33	3	0	0	2	0
9	1	2.60	2.60	4.00	-	3	0	0	2	0
10	15	2.44	2.44	3.75	1.69,1.68,1.69,1.68,1.69,1.69,1.68,1.68,1.68,1.68,1.69,1.69,1.69,1.68,1.68,1.68,1.69,1.69,1.69,1.69,1.69,1.69	3	0	0	2	0
11	18	4.20	4.20	2.00	2.33,2.33	3	0	0	2	0
12	4	1.30	1.30	2.00	-	3	0	0	2	0
13	18	4.88	4.00	7.50	1.09,1.09	3	0	0	2	0
14	18	4.88	4.00	7.50	1.09,1.09	3	0	0	2	0
15	18	4.20	4.20	2.00	2.33,2.33	3	0	0	2	0
16	18	4.20	4.20	2.00	2.33,2.33	3	0	0	2	0

Member Design Capacity

Member ID	$\Phi_c P_n$ (kip)	$\Phi_t P_n$ (kip)	$\Phi_b M_{zn}$ (k-ft)	$\Phi_b M_{yn}$ (k-ft)	$\Phi_v V_{yn}$ (kip)	$\Phi_v V_{zn}$ (kip)
1	251.16	86.89	42.30	42.30	75.35	75.35
2	142.83	141.72	16.17	16.17	42.85	42.85
3	79.65	74.02	10.99	4.60	29.14	16.61
4	79.65	72.01	10.99	4.60	29.14	16.61
5	79.65	73.44	10.99	4.60	29.14	16.61
6	79.65	74.02	10.99	4.60	29.14	16.61
7	79.65	73.44	10.99	4.60	29.14	16.61
8	120.60	96.18	23.36	6.45	30.09	45.74
9	48.35	43.11	2.85	2.85	14.51	14.51
10	79.65	72.01	10.99	4.60	29.14	16.61

11	120.60	96.18	23.36	6.45	30.09	45.74
12	142.83	141.72	16.17	16.17	42.85	42.85
13	120.60	98.23	19.19	6.45	30.09	45.74
14	120.60	98.23	19.19	6.45	30.09	45.74
15	120.60	96.18	23.36	6.45	30.09	45.74
16	120.60	96.18	23.36	6.45	30.09	45.74

Design Ratio

Member ID	P	M _z	M _y	V _y	V _z	(P,M _z ,M _y)	Worst LC	KL/r	δ	Status
1	0.030	0.001	0.000	0.000	0.000	0.015	#6	0.602	Not Required	Pass
2	0.000	0.102	0.017	0.027	0.000	0.120	#6	0.052	Not Required	Pass
3	0.006	0.109	0.081	0.011	0.015	0.193	#6	0.044	Not Required	Pass
4	0.006	0.108	0.075	0.011	0.011	0.181	#6	0.078	Not Required	Pass
5	0.006	0.067	0.073	0.011	0.010	0.078	#6	0.073	Not Required	Pass
6	0.006	0.109	0.081	0.011	0.015	0.193	#6	0.044	Not Required	Pass
7	0.006	0.067	0.073	0.011	0.010	0.078	#6	0.073	Not Required	Pass
8	0.000	0.005	0.024	0.004	0.003	0.028	#6	Not Required	Not Required	Pass
9	0.002	0.005	0.011	0.001	0.000	0.017	#6	0.132	Not Required	Pass
10	0.006	0.108	0.075	0.011	0.011	0.181	#6	0.078	Not Required	Pass
11	0.000	0.005	0.024	0.004	0.003	0.028	#6	Not Required	Not Required	Pass
12	0.000	0.102	0.017	0.027	0.000	0.120	#6	0.052	Not Required	Pass
13	0.001	0.022	0.084	0.007	0.006	0.103	#6	0.177	Not Required	Pass
14	0.002	0.023	0.084	0.007	0.006	0.103	#6	0.177	Not Required	Pass
15	0.000	0.005	0.024	0.004	0.003	0.028	#6	Not Required	Not Required	Pass
16	0.000	0.005	0.024	0.004	0.003	0.028	#6	Not Required	Not Required	Pass

Definitions

Φ _t	Safety factor for tensile
Φ _c	Safety factor for compression
Φ _b	Safety factor for flexure
Φ _v	Safety factor for shear
E	Modulus of elasticity
F _y	Specified minimum yield stress
F _u	Specified minimum tensile strength
A	Cross-sectional area
J	Torsional constant
I _{yp}	Moment of inertia about the Y axes
I _{zp}	Moment of inertia about the Z axes
I _w	Warping constant
S _{yp}	Plastic section modulus about the Y axis
S _{zp}	Plastic section modulus about the Z axis
KL	Effective length
C _b	Buckling modification factor (from all load combinations)
L _b	Length between braced points
LST	Limited slenderness for tension
LSC	Limited slenderness for compression
LD	Limited deflection
P _n	Nominal axial strength (tension/compression)
M _n	Nominal flexural strength (about Z/Y axis)
V _n	Nominal shear strength (along Z/Y axis)
P	Design ratio in case of axial force
M _z	Design ratio in case of bending about Z axis
M _y	Design ratio in case of bending about Y axis
V _y	Design ratio in case of shear along Y axis
V _z	Design ratio in case of shear along Z axis
(P,M _z ,M _y)	Design ratio in case of axial force and bending action
KL/r	Design ratio in case of section slenderness
δ	Design ratio in case of member deflection
OK	Capacity is provided
NG	Capacity is not provided

Capacity is not provided

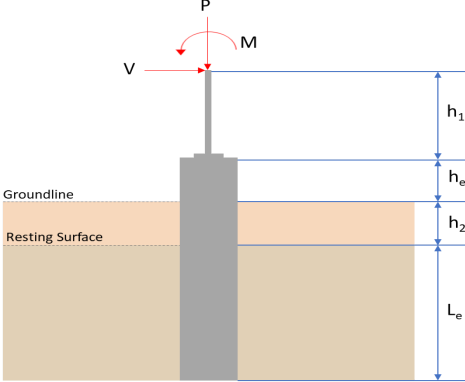
REFERENCES	CALCULATIONS	RESULTS																										
	<p>SkyCiv Foundation Design Pile Foundation</p> <p>Design Information : Design code : IBC 2021 (International Building Code) Unit System : Imperial</p>																											
	<p>Pile Input</p>  <p>Geometry</p> <p>Pile shape: rectangular $b = 48$ in - Pile width $D = 48$ in - Pile depth $L = 3$ ft - Total pile length $h_1 = 0$ ft - Lateral load height from the top of the pile, $h_2 = 0$ ft - Depth to resting surface $h_e = 0$ ft - Length of pile above the ground</p> <p>Tabulation of Soil Parameters</p> <table border="1" data-bbox="416 1102 1193 1191"> <thead> <tr> <th>Layer</th> <th>Label</th> <th>Allowable Bearing Pressure (q_a) (psf)</th> <th>Allowable Lateral Pressure (R) (psf/ft)</th> </tr> </thead> <tbody> <tr> <td>1</td> <td>Sand, silty sand, clayey sand, silty gravel & clayey gravel</td> <td>2000.000</td> <td>150.000</td> </tr> </tbody> </table> <p>Tabulation of Loads</p> <table border="1" data-bbox="676 1288 935 1458"> <thead> <tr> <th>Load Component</th> <th>ASD</th> <th>LRFD</th> </tr> </thead> <tbody> <tr> <td>P (kip)</td> <td>1.943</td> <td>2.575</td> </tr> <tr> <td>V_x (kip)</td> <td>0.000</td> <td>0.000</td> </tr> <tr> <td>V_z (kip)</td> <td>0.000</td> <td>0.000</td> </tr> <tr> <td>M_x (kipft)</td> <td>0.000</td> <td>0.000</td> </tr> <tr> <td>M_z (kipft)</td> <td>0.014</td> <td>0.023</td> </tr> </tbody> </table> <p>Material Properties</p> <p>$f'_{ck} = 2.5$ ksi - Concrete strength,</p>	Layer	Label	Allowable Bearing Pressure (q_a) (psf)	Allowable Lateral Pressure (R) (psf/ft)	1	Sand, silty sand, clayey sand, silty gravel & clayey gravel	2000.000	150.000	Load Component	ASD	LRFD	P (kip)	1.943	2.575	V_x (kip)	0.000	0.000	V_z (kip)	0.000	0.000	M_x (kipft)	0.000	0.000	M_z (kipft)	0.014	0.023	
Layer	Label	Allowable Bearing Pressure (q_a) (psf)	Allowable Lateral Pressure (R) (psf/ft)																									
1	Sand, silty sand, clayey sand, silty gravel & clayey gravel	2000.000	150.000																									
Load Component	ASD	LRFD																										
P (kip)	1.943	2.575																										
V_x (kip)	0.000	0.000																										
V_z (kip)	0.000	0.000																										
M_x (kipft)	0.000	0.000																										
M_z (kipft)	0.014	0.023																										
	<p>Required depth to resist lateral loads (ASD)</p> <p>H - Point of application of the lateral load</p> $H = h_1 + h_2 + h_e$ $H = (0 \text{ ft}) + (0 \text{ ft}) + (0 \text{ ft})$ $H = 0 \text{ ft}$ <p>Considering x-direction:</p> <p>H_o - Lateral force per length of pile,</p> $H_o = \frac{V_x}{1.57 D}$ $H_o = \frac{(0 \text{ kip})}{1.57 \times (48 \text{ in})}$ $H_o = 0 \text{ kip/ft}$ <p>M_o - Moment per length of pile,</p> $M_o = \frac{M_z + (V_x H)}{1.57 D}$																											

$$M_o = \frac{(0.014 \text{ kipft}) + ((0 \text{ kip}) \times (0 \text{ ft}))}{1.57 \times (48 \text{ in})}$$

$$M_o = 0.0022293 \text{ kipft/ft}$$

L_e - Required depth of embedment in earth,

$$L_e = 2.29 \sqrt[3]{\frac{M_o}{R}}$$

$$L_e = 2.29 \times \sqrt[3]{\frac{(0.0022293 \text{ kipft/ft})}{(150 \text{ psf/ft})}}$$

$$L_e = 0.56303 \text{ ft}$$

Considering z-direction:

$L_{e,z} = 0 \text{ ft}$ - Required depth in z-direction,

Minimum embedded depth required:

$L_{e,req}$ - Depth of pile required,

$$L_{e,req} = \text{MAX}[L_e, L_{e,z}]$$

$$L_{e,req} = \text{MAX}[(0.56303 \text{ ft}), (0 \text{ ft})]$$

$$L_{e,req} = 0.563 \text{ ft}$$

L_e - Actual embedded length of pile,

$$L_e = L - h_e - h_2$$

$$L_e = (3 \text{ ft}) - (0 \text{ ft}) - (0 \text{ ft})$$

$$L_e = 3 \text{ ft}$$

Ratio - Embedded depth

$$\text{Ratio} = \frac{L_{e,req}}{L_e}$$

$$\text{Ratio} = \frac{(0.563 \text{ ft})}{(3 \text{ ft})}$$

$$\text{Ratio} = 0.18767$$

Status: **PASS**
Ratio: **0.190**

End-bearing Capacity (ASD)

A - Pile cross-section area

$$A = b D$$

$$A = (48 \text{ in}) \times (48 \text{ in})$$

$$A = 16 \text{ ft}^2$$

q - End-bearing pressure

$$q = \frac{P_v}{A}$$

$$q = \frac{(1.943 \text{ kip})}{(16 \text{ ft}^2)}$$

$$q = 0.12144 \text{ kip/ft}^2$$

Check bearing capacity ratio:

Ratio - Capacity

$$\text{Ratio} = \frac{q}{q_a}$$

$$\text{Ratio} = \frac{(0.12144 \text{ kip/ft}^2)}{(2000 \text{ psf})}$$

$$\text{Ratio} = 0.060719$$

Status: **PASS**
Ratio: **0.060**

Czerniak

Lateral Soil Pressure (ASD):

L/D - Length to least lateral dimension ratio,

$$L/D = \frac{L}{D}$$

$$L/D = \frac{(3 \text{ ft})}{(48 \text{ in})}$$

$$L/D = 0.75$$

Since $L/D \leq 10$,

Pile is short.

Considering x-direction:

$H_o = 0 \text{ kip/ft}$ - Lateral force per length of pile,

$M_o = 0.0022293 \text{ kipft/ft}$ - Overturning moment per length of pile,

a - Distance from resting surface to pivot point,

$$a = \frac{(4 M_o L_e) + (3 H_o L_e^2)}{(6 M_o) + (4 H_o L_e)}$$

$$a = \frac{(4 \times (0.0022293 \text{ kipft/ft}) \times (3 \text{ ft})) + (3 \times (0 \text{ kip/ft}) \times (3 \text{ ft})^2)}{(6 \times (0.0022293 \text{ kipft/ft})) + (4 \times (0 \text{ kip/ft}) \times (3 \text{ ft}))}$$

$$a = 2 \text{ ft}$$

p - Earth pressure against the pile at distance $a/2$ from resting surface,

$$p = \frac{0.75 [(4 M_o) + (3 H_o L_e)]^2}{L_e^2 [(3 M_o) + (2 H_o L_e)]}$$

$$p = \frac{0.75 \times [(4 \times (0.0022293 \text{ kipft/ft})) + (3 \times (0 \text{ kip/ft}) \times (3 \text{ ft}))]^2}{(3 \text{ ft})^2 \times [(3 \times (0.0022293 \text{ kipft/ft})) + (2 \times (0 \text{ kip/ft}) \times (3 \text{ ft}))]}$$

$$p = 0.0009908 \text{ kip/ft}^2$$

s - Earth pressure against the pile at distance L_e ,

$$s = \frac{6 [(2 M_o) + (H_o L_e)]}{L_e^2}$$

$$s = \frac{6 \times [(2 \times (0.0022293 \text{ kipft/ft})) + ((0 \text{ kip/ft}) \times (3 \text{ ft}))]}{(3 \text{ ft})^2}$$

$$s = 0.0029724 \text{ kip/ft}^2$$

Check lateral soil pressure capacity:

p_a - Allowable lateral soil pressure at depth $a/2$,

$$p_a = R \frac{a}{2}$$

$$p_a = (150 \text{ psf/ft}) \times \frac{(2 \text{ ft})}{2}$$

$$p_a = 0.15 \text{ kip/ft}^2$$

Ratio - Lateral soil capacity

$$\text{Ratio} = \frac{p}{p_a}$$

$$\text{Ratio} = \frac{(0.0009908 \text{ kip/ft}^2)}{(0.15 \text{ kip/ft}^2)}$$

$$\text{Ratio} = 0.0066053$$

Status: **PASS**
Ratio: **0.010**

p_s - Allowable lateral soil pressure at depth L_e ,

$$p_s = R L_e$$

$$p_s = (150 \text{ psf/ft}) \times (3 \text{ ft})$$

$$p_s = 0.45 \text{ kip/ft}^2$$

Ratio - Lateral soil capacity

$$\text{Ratio} = \frac{s}{p_s}$$

$$\text{Ratio} = \frac{(0.0029724 \text{ kip/ft}^2)}{(0.45 \text{ kip/ft}^2)}$$

$$\text{Ratio} = 0.0066053$$

Status: **PASS**
Ratio: **0.010**



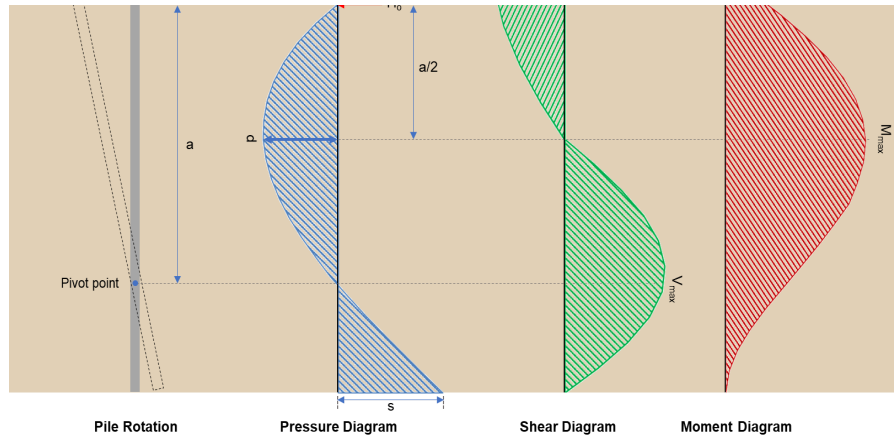

Shear force and Bending moment (x-direction, LRFD)

H_o - Lateral force per length of pile,

$$H_o = \frac{V_x}{1.57 D}$$

$$H_o = \frac{(0 \text{ kip})}{1.57 \times (48 \text{ in})}$$

$$H_o = 0 \text{ kip/ft}$$

M_o - Moment per length of pile,

$$M_o = \frac{M_z + (V_x H)}{1.57 D}$$

$$M_o = \frac{(0.023 \text{ kipft}) + ((0 \text{ kip}) \times (0 \text{ ft}))}{1.57 \times (48 \text{ in})}$$

$$M_o = 0.0036624 \text{ kipft/ft}$$

a - Distance from resting surface to pivot point,

$$a = \frac{(4 M_o L_c) + (3 H_o L_c^2)}{(6 M_o) + (4 H_o L_c)}$$

$$a = \frac{(4 \times (0.0036624 \text{ kipft/ft}) \times (3 \text{ ft})) + (3 \times (0 \text{ kip/ft}) \times (3 \text{ ft})^2)}{(6 \times (0.0036624 \text{ kipft/ft})) + (4 \times (0 \text{ kip/ft}) \times (3 \text{ ft}))}$$

$$a = 2 \text{ ft}$$

V_{max} - Max shear force located at depth a ,

$$V_{max} = 12 \left(\frac{M_o D}{L_c} \right) \left(\frac{a}{L_c} - 1 \right) \left(\frac{a}{L_c} \right)^2$$

$$V_{max} = 12 \times \left(\frac{(0.0036624 \text{ kipft/ft}) \times (48 \text{ in})}{(3 \text{ ft})} \right) \times \left(\frac{(2 \text{ ft})}{(3 \text{ ft})} - 1 \right) \times \left(\frac{(2 \text{ ft})}{(3 \text{ ft})} \right)^2$$

$$V_{max} = 0.0086813 \text{ kip}$$

M_{max} - Max bending moment at depth $a/2$,

$$M_{max} = (M_o D) \left[1 - \left(4 \frac{a}{2 L_c} \right)^3 + \left(3 \frac{a}{2 L_c} \right)^4 \right]$$

$$M_{max} = ((0.0036624 \text{ kipft/ft}) \times (48 \text{ in})) \times \left[1 - \left(4 \times \frac{(2 \text{ ft})}{2 \times (3 \text{ ft})} \right)^3 + \left(3 \times \frac{(2 \text{ ft})}{2 \times (3 \text{ ft})} \right)^4 \right]$$

$$M_{max} = 0.013022 \text{ kipft}$$

Minimum Reinforcement Check (LRFD)

Parameters:

- $f'_{ck} = 2.5 \text{ ksi}$ - Concrete strength,
- $f_{yk} = 60 \text{ ksi}$ - Longitudinal reinforcement strength,
- $\phi = 0.65$ - Reduction factor for axial strength,
- $\alpha = 0.8$ - Alpha factor for axial strength,
- $A_g = 2304 \text{ in}^2$ - Gross area of concrete,

Longitudinal reinforcement:

Required reinforcement due to axial load, $A_{st,required}$
 $A_{st,required}$

Table 22.4.2.1

22.4.2.2, 10.6.1.1

	$A_{st,required} = Min \left[\frac{\phi \alpha \sum J_{ck}^{2.9g}}{f_{yk} - (0.85 f'_{ck})}, (0.08 A_g) \right]$ $A_{st,required} = Min \left[\frac{\frac{(2.575 \text{ kip})}{(0.65) \times (0.8)} - (0.85 \times (2.5 \text{ ksi}) \times (2304 \text{ in}^2))}{(60 \text{ ksi}) - (0.85 \times (2.5 \text{ ksi}))}, (0.08 \times (2304 \text{ in}^2)) \right]$ $A_{st,required} = -84.511 \text{ in}^2$ <p><i>A_{min}</i> - Governing minimum reinforcement area,</p> $A_{min} = Max [A_{st,required}, (0.0018 A_g)]$ $A_{min} = Max [(-84.511 \text{ in}^2), (0.0018 \times (2304 \text{ in}^2))]$ $A_{min} = 4.1472 \text{ in}^2$ <p><i>n_{rebar}</i> - Required number of reinforcement,</p> $n_{rebar} = \frac{A_{min}}{A_{rebar}}$ $n_{rebar} = \frac{(4.1472 \text{ in}^2)}{(0.3068 \text{ in}^2)}$ $n_{rebar} = 14$ <p><i>A_{st}</i> - Actual total reinforcement area,</p> $A_{st} = n_{rebar} \frac{\pi d_{bar}^2}{4}$ $A_{st} = (14) \times \frac{\pi \times (0.625 \text{ in})^2}{4}$ $A_{st} = 4.2951 \text{ in}^2$ <p><i>Ratio</i> - Capacity</p> $Ratio = \frac{A_{min}}{A_{st}}$ $Ratio = \frac{(4.1472 \text{ in}^2)}{(4.2951 \text{ in}^2)}$ $Ratio = 0.96556$ <p>25.2.3 <i>s_{rebar}</i> - Minimum spacing of reinforcement,</p> $s_{rebar} = Max [1.5, (1.5 d_{bar})]$ $s_{rebar} = Max [1.5, (1.5 \times (0.625 \text{ in}))]$ $s_{rebar} = 1.5 \text{ in}$ <p>Ties:</p> <p>25.7.2.2 Since longitudinal reinforcement is ≤ No. 10Ø: Use #3(0.375 in)</p> <p>25.7.2.1 <i>s_{ties}</i> - Maximum spacing of ties,</p> $s_{ties} = Min [(16 d_{bar}), (48 d_{ties}), Min (D, b)]$ $s_{ties} = Min [(16 \times (0.625 \text{ in})), (48 \times (0.375 \text{ in})), Min ((48 \text{ in}), (48 \text{ in}))]$ $s_{ties} = 10 \text{ in}$ <p>Summary:</p> <p style="text-align: center;">Main reinforcement: 14 - #5 (0.625 in) Ties: #3(0.375 in) - 10 in</p>	<p>Status: PASS Ratio: 0.970</p>
<p>22.4.2.2</p>	<p>Axial Compression Strength (ACI 318-19, LRFD)</p> <p><i>φP_N</i> - Allowable axial compressive strength</p> $\phi P_N = \phi 0.80 [(0.85 f'_{ck} [A_g - A_{st}]) + (f_{yk} A_{st})]$ $\phi P_N = (0.65) \times 0.80 \times [(0.85 \times (2.5 \text{ ksi}) \times [(2304 \text{ in}^2) - (4.2951 \text{ in}^2)]) + ((60 \text{ ksi}) \times (4.2951 \text{ in}^2))]$ $\phi P_N = 2675.2 \text{ kip}$ <p><i>Ratio</i> - Capacity</p> $Ratio = \frac{P}{\phi P_N}$	

$$Ratio = \frac{(2.575 \text{ kip})}{(2675.2 \text{ kip})}$$

$$Ratio = 0.00096255$$

Status: **PASS**
Ratio: **0.000**

Shear Strength (ACI 318-19, LRFD)

Parameters:

22.5.2.2 $b_w = 48 \text{ in}$ - Effective width,
 d - Effective depth

$$d = 0.80 D$$

$$d = 0.80 \times (48 \text{ in})$$

$$d = 38.4 \text{ in}$$

22.5.5.1.3 λ_s - size effect modification factor

$$\lambda_s = MIN \left[\sqrt{\frac{2}{1 + \frac{d}{10}}}, 1 \right]$$

$$\lambda_s = MIN \left[\sqrt{\frac{2}{1 + \frac{(38.4 \text{ in})}{10}}}, 1 \right]$$

$$\lambda_s = 0.64282$$

22.5.5.1.1 The following variables were converted to be consistent with empirical formula $f'_{ck} = 2.5 \text{ ksi} \rightarrow 2500 \text{ psi}$,
 $V_{c,max}$ - Max shear strength of concrete

$$V_{c,max} = 5 \lambda_s \sqrt{f'_{ck}} b_w d$$

$$V_{c,max} = 5 \times (0.64282) \times \sqrt{(2500 \text{ psi})} \times (48 \text{ in}) \times (38.4 \text{ in})$$

$$V_{c,max} = 296.21 \text{ kip}$$

22.5.5.1.1(a) The following variables were converted to be consistent with empirical formula $f'_{ck} = 2.5 \text{ ksi} \rightarrow 2500 \text{ psi}$, $P = 2.575 \text{ kip} \rightarrow 2575 \text{ lbf}$,
 $V_{c,a}$ - Shear strength of concrete (a)

$$V_{c,a} = \left[2 \lambda_s \sqrt{f'_{ck}} + \frac{P}{6 A_g} \right] b_w d$$

$$V_{c,a} = \left[2 \times (0.64282) \times \sqrt{(2500 \text{ psi})} + \frac{(2575 \text{ lbf})}{6 \times (2304 \text{ in}^2)} \right] \times (48 \text{ in}) \times (38.4 \text{ in})$$

$$V_{c,a} = 118.83 \text{ kip}$$

22.5.5.1.2 The following variables were converted to be consistent with empirical formula $f'_{ck} = 2.5 \text{ ksi} \rightarrow 2500 \text{ psi}$,
 $V_{c,b}$ - Shear strength of concrete (b)

$$V_{c,b} = \left[2 \lambda_s \sqrt{f'_{ck}} + (0.05 f'_{ck}) \right] b_w d$$

$$V_{c,b} = \left[2 \times (0.64282) \times \sqrt{(2500 \text{ psi})} + (0.05 \times (2500 \text{ psi})) \right] \times (48 \text{ in}) \times (38.4 \text{ in})$$

$$V_{c,b} = 348.89 \text{ kip}$$

V_c - Governing shear strength of concrete

$$V_c = Min[V_{c,max}, V_{c,a}, V_{c,b}]$$

$$V_c = Min[(296.21 \text{ kip}), (118.83 \text{ kip}), (348.89 \text{ kip})]$$

$$V_c = 118.83 \text{ kip}$$

22.5.1.2 The following variables were converted to be consistent with empirical formula $f'_{ck} = 2.5 \text{ ksi} \rightarrow 2500 \text{ psi}$,
 $V_{s,a}$ - Shear strength of steel (a)

$$V_{s,a} = 8 \sqrt{f'_{ck}} b_w d$$

$$V_{s,a} = 8 \times \sqrt{(2500 \text{ psi})} \times (48 \text{ in}) \times (38.4 \text{ in})$$

$$V_{s,a} = 737.28 \text{ kip}$$

A_v - Ties rebar area,

$$A_v = \frac{\pi d_{ties}^2}{4}$$

$$A_v = \pi \times (0.375 \text{ in})^2$$

<p>22.5.8.5.3 $V_{s,b}$ - Shear strength of steel (b)</p>	$A_v = \frac{A_v}{4}$ $A_v = 0.11045 \text{ in}^2$ $V_{s,b} = \frac{2 A_v f_{ywk} d}{s_{ties}}$ $V_{s,b} = \frac{2 \times (0.11045 \text{ in}^2) \times (60 \text{ ksi}) \times (38.4 \text{ in})}{(10 \text{ in})}$ $V_{s,b} = 50.894 \text{ kip}$ <p>V_s - Governing shear strength of steel</p> $V_s = \text{MIN}[V_{s,a}, V_{s,b}]$ $V_s = \text{MIN}[(737.28 \text{ kip}), (50.894 \text{ kip})]$ $V_s = 50.894 \text{ kip}$	
<p>22.5.1.1 ϕV_n - Allowable shear strength</p>	$\phi V_n = \phi (V_c + V_s)$ $\phi V_n = (0.65) \times ((118.83 \text{ kip}) + (50.894 \text{ kip}))$ $\phi V_n = 110.32 \text{ kip}$	
	<p>Flexural Strength (ACI 318-19, LFRD)</p> <p>S_m - Section modulus</p> $S_m = \frac{b D^2}{6}$ $S_m = \frac{(48 \text{ in}) \times (48 \text{ in})^2}{6}$ $S_m = 18432 \text{ in}^3$ <p>$\lambda = 1$ - Concrete modification factor (Normal concrete), Allowable flexural strength: M_n shall be the lesser of:</p> <p>$\phi M_{n,1}$</p> $\phi M_{n,1} = \phi \times 5 \times \lambda \times \sqrt{f'_c} \times S_m$ $\phi M_{n,1} = 0.65 \times 5 \times 1 \times \sqrt{2.5 \text{ ksi}} \times 18432.001 \text{ in}^3$ $\phi M_{n,1} = 249.600 \text{ kipft}$ <p>$\phi M_{n,2}$</p> $\phi M_{n,2} = \phi \times 0.85 f'_c S_m$ $\phi M_{n,2} = (0.65) \times 0.85 \times (2.5 \text{ ksi}) \times (18432 \text{ in}^3)$ $\phi M_{n,2} = 2121.6 \text{ kipft}$ <p>Therefore, ϕM_n - Allowable flexural strength,</p> $\phi M_n = \text{MIN}[\phi M_{n,1}, \phi M_{n,2}]$ $\phi M_n = \text{MIN}[(249.6 \text{ kipft}), (2121.6 \text{ kipft})]$ $\phi M_n = 249.6 \text{ kipft}$ <p>Considering x-direction:</p> <p>$M_{max} = 0.013022 \text{ kipft}$ - Maximum moment in the x-direction, Ratio - Capacity</p> $\text{Ratio} = \frac{M_{max}}{\phi M_n}$ $\text{Ratio} = \frac{(0.013022 \text{ kipft})}{(249.6 \text{ kipft})}$ $\text{Ratio} = 0.000052171$	<p>Status: PASS Ratio: 0.000</p>

