

Your Project Calculations



Project Name: MTSOLAR_E1E0CG8K9BKF

S3D Model Link:

https://platform.skyciv.com/structural?preload_name=MTSOLAR_E1E0CG8K9BKF&preload_path=Shared%20Enterprise%20Folder/MT_Solar_Projects/6_2023

Public Model Link:

https://platform.skyciv.com/structural-viewer?project_id=v6qeowGdEUWmVnMshubDxIlvzVRIDVXNCoGWNiQXGO62fdHtr06cvHyYIm1IGKpV

Array Specification

Product:	Beam
Unique ID:	1P-0-10TOP-XD-57-L-4Hx3W-CLIG
Duty Classification:	XD
Module Width:	41.00 in
Module Length:	69.00in
Number of Rows:	4
Number of Columns:	3
Total Number of Modules:	12
Desired Tilt Angle:	45
Front Edge Clearance:	4
Total Array Height at Tilt:	13.72 ft
Total Frame Length:	17.00 ft
Frame Weight:	1040 lbs
Array Dimensions N/S:	13.83 ft
Array Dimensions E/W:	17.50 ft
Rail Length:	166.00 in
Rail Spacing:	2.88 ft
Rail Check:	Not Checked

Support Specifications

Pole Size:	10in Pipe Sch 40
Pole Length above Grade:	8.89 ft
Number of Poles:	1
Pole Spacing:	0

Foundation Specifications

Foundation Type:	Square
Foundation Dimensions:	48 x 48 in
Foundation Depth (below grade):	Pile 1: 6.75 ft
Foundation Volume:	4.000 y ³
Foundation Result:	PASSED
Mount Twist:	0.000005 kip

Site Info

Risk Category:	I
Exposure:	C
Soil Classification:	sand
Site Location:	908 Moody Mountain Rd, Lincolnville, ME 04849, USA
Wind Speed:	102 mph
Snow Load:	60 psf
Design Uplift Pressure:	Multiple pressures
Design Downforce Pressure:	Multiple pressures
Design Snow Pressure:	0.016495 ksf



Design Disclaimer

This software should be used for preliminary designs and should not be used as a final design unless reviewed, verified and designed by a qualified structural engineer.

AutoDesigner Input

```
{
  "wind_speed_override": null,
  "snow_load_override": null,
  "direct_snow_load": false,
  "product_type": "Beam",
  "project_id": "MTSOLAR_E1E0C G8K9BKF",
  "site_address": "908 Moody Mountain Rd, Lincolnville, ME 04849, USA",
  "module_width": 41,
  "module_length": 69,
  "number_rows": 4,
  "number_columns": 3,
  "pole_mount_section": "4_40",
  "core_pipe_width": 65,
  "core_pipe_section": "2_40",
  "adjuster_section": "2_40",
  "core_beam_height": 65,
  "core_beam_section": "HSS3x2x1/8",
  "main_pipe_section": "2_12GA",
  "pole_spacing": 15,
  "tilt_angle": 45,
  "ground_clearance": 4,
  "risk_category": "I",
  "exposure_category": "C",
  "frame_duty_override": "auto",
  "pole_override": "auto",
  "soil_type": "sand",
  "foundation_type": "Square",
  "foundation_size": 48,
  "check_rails": false
}
```

Design Notes:

- AISC Deflection checks are set to L/1 due to structure design intent
- Foundation Design and Sizing is approximate only

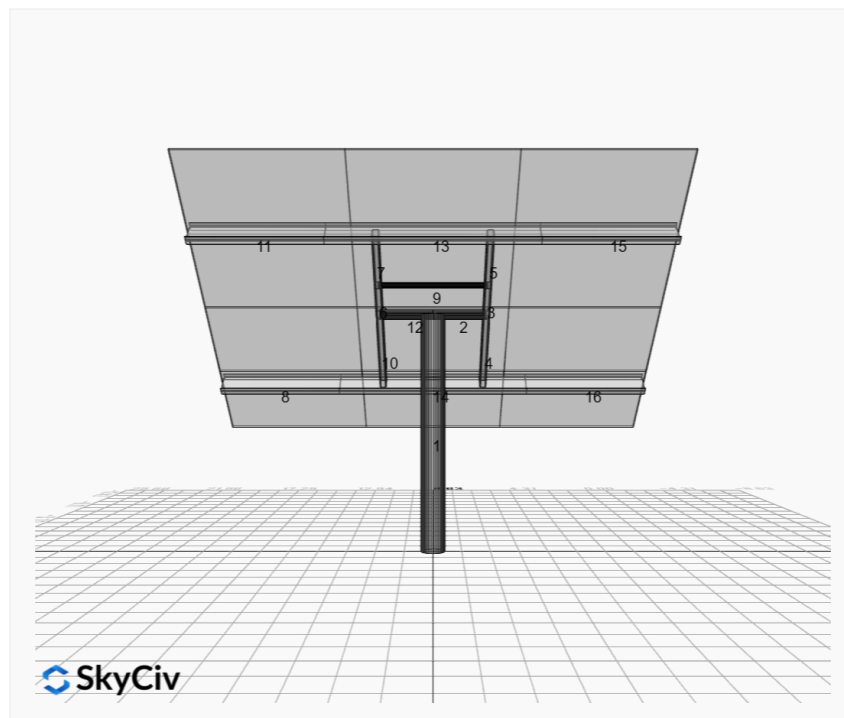

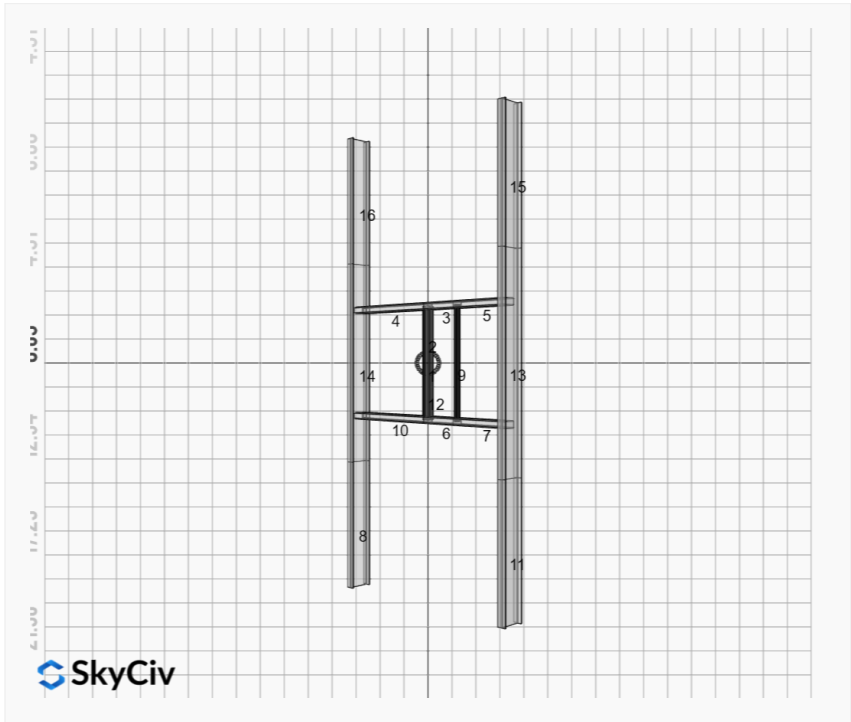
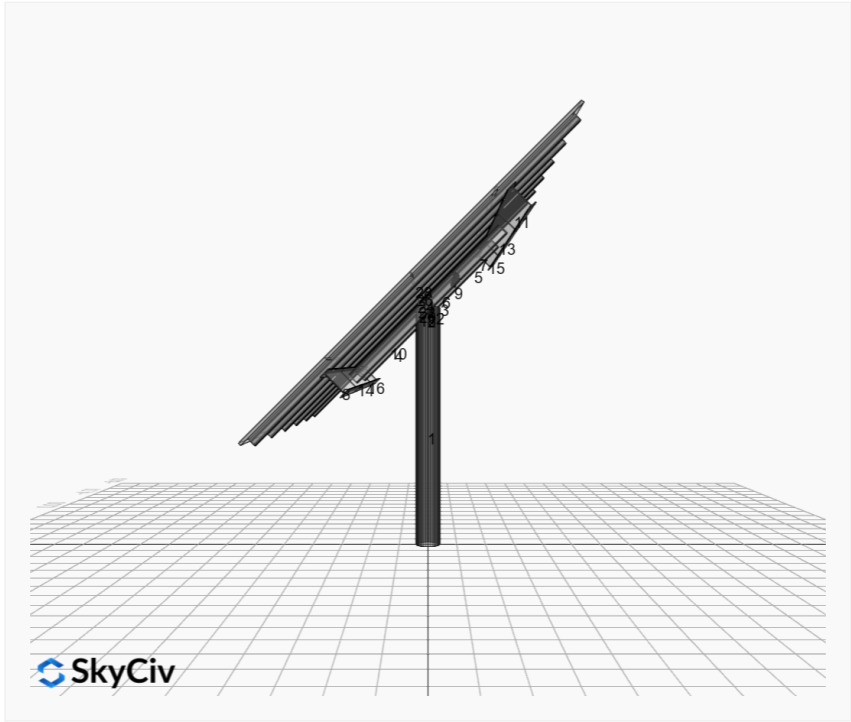

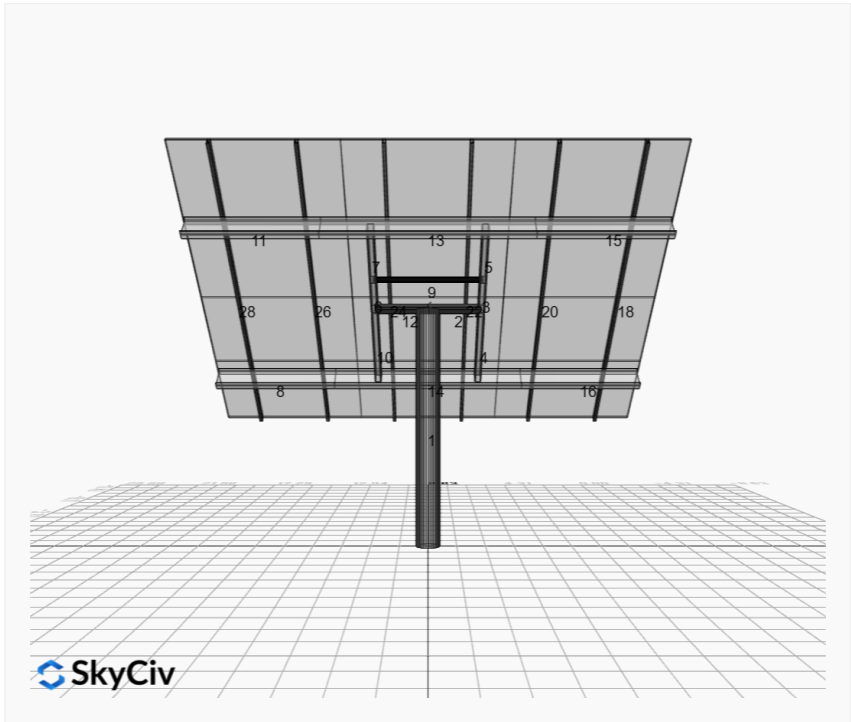
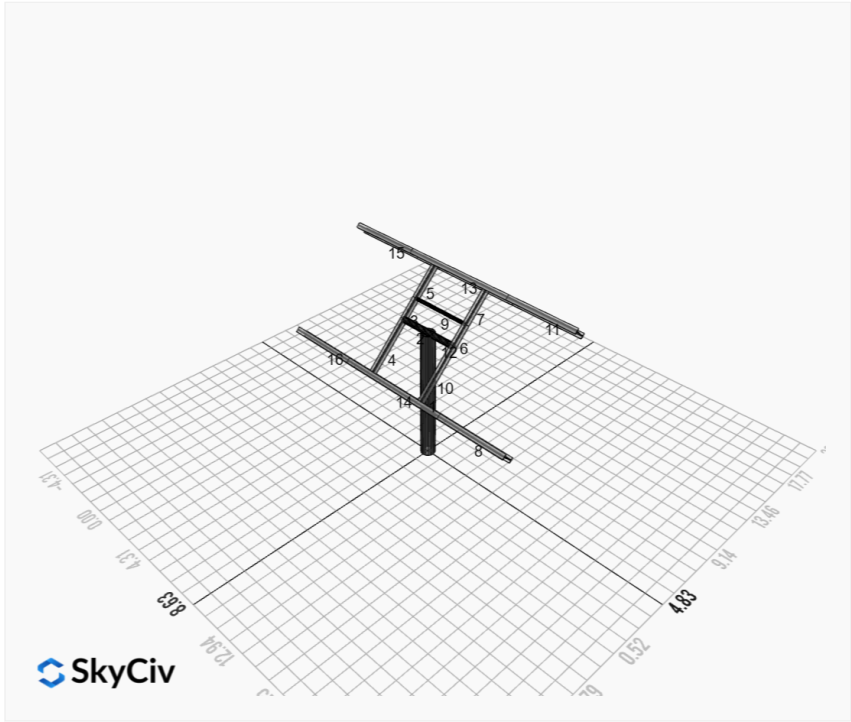

FEM Results (Envelope Worst Case for each member)

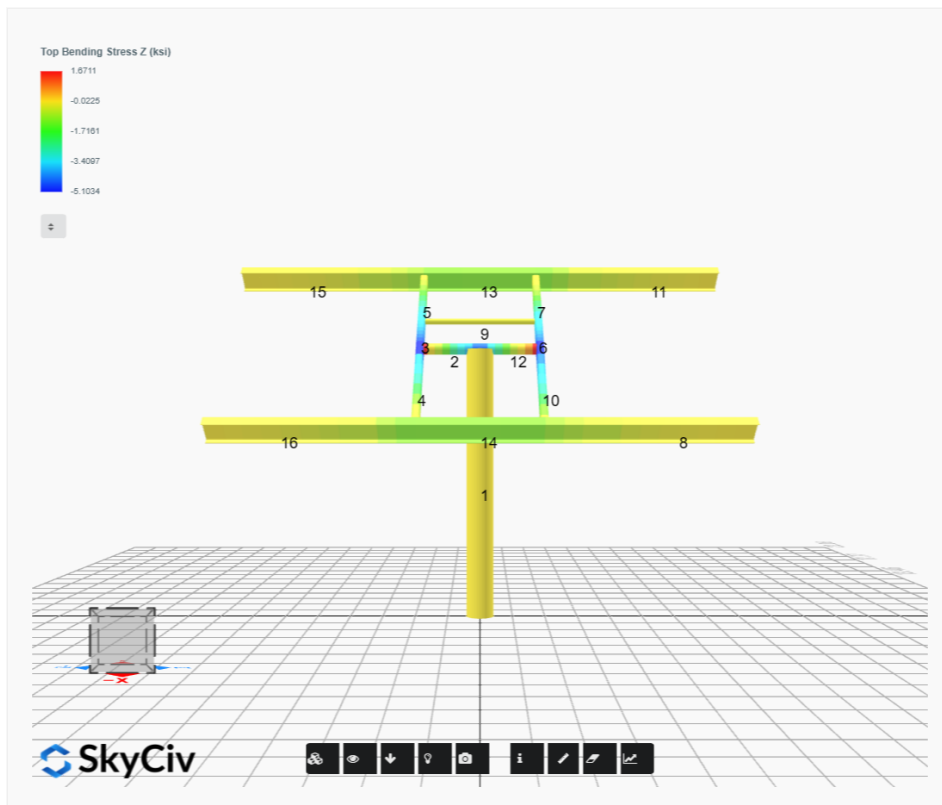
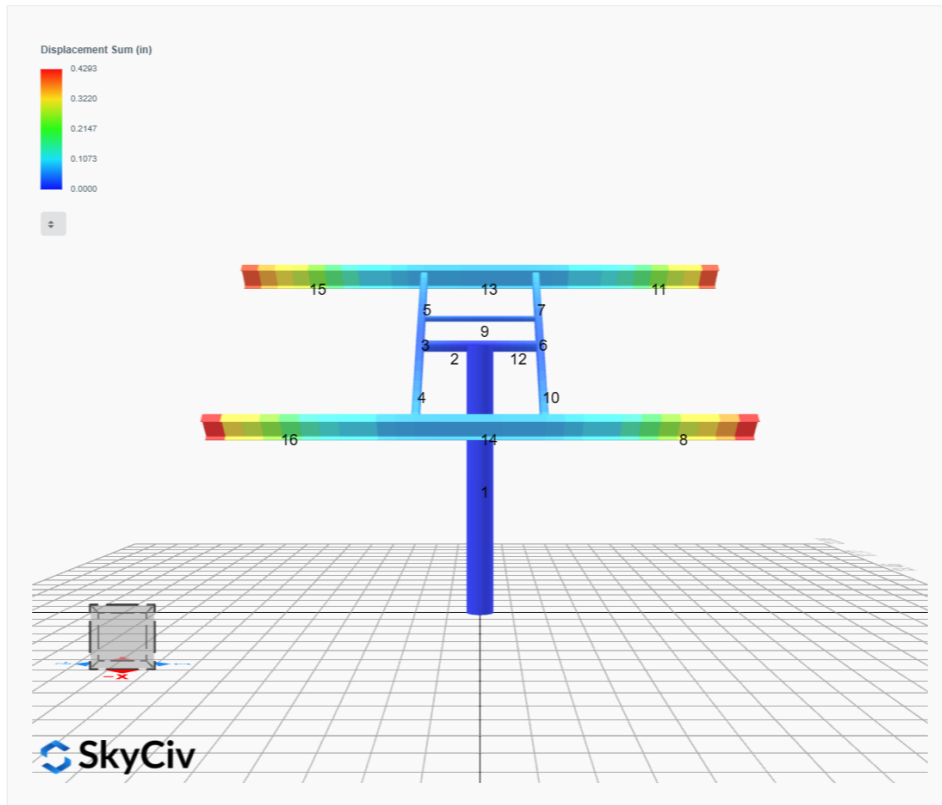

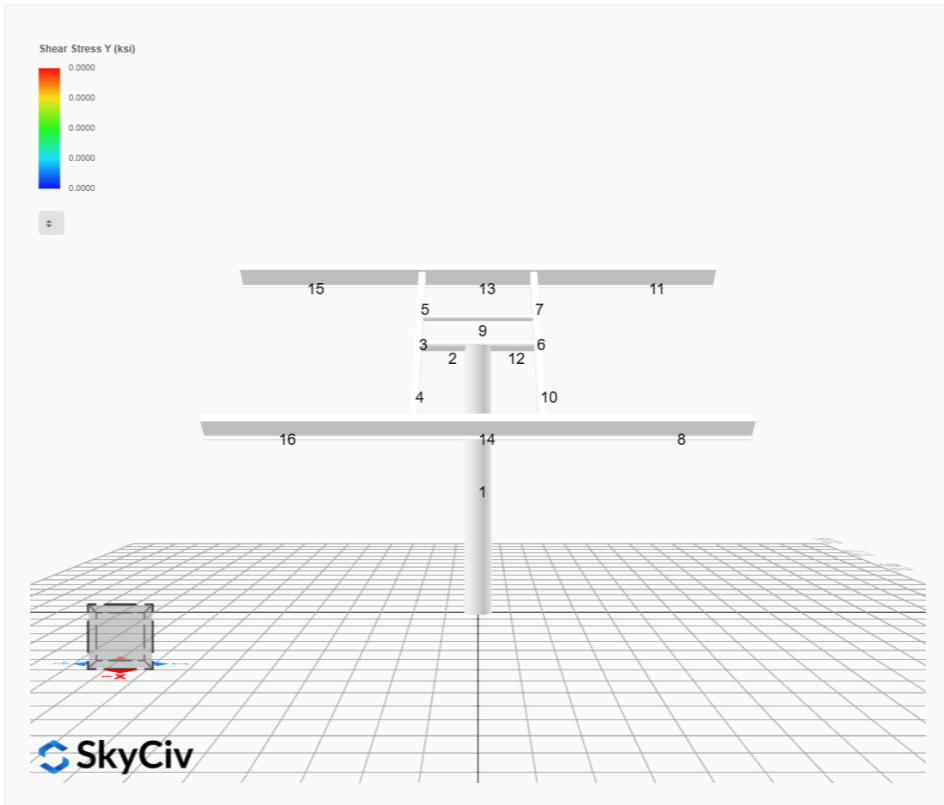
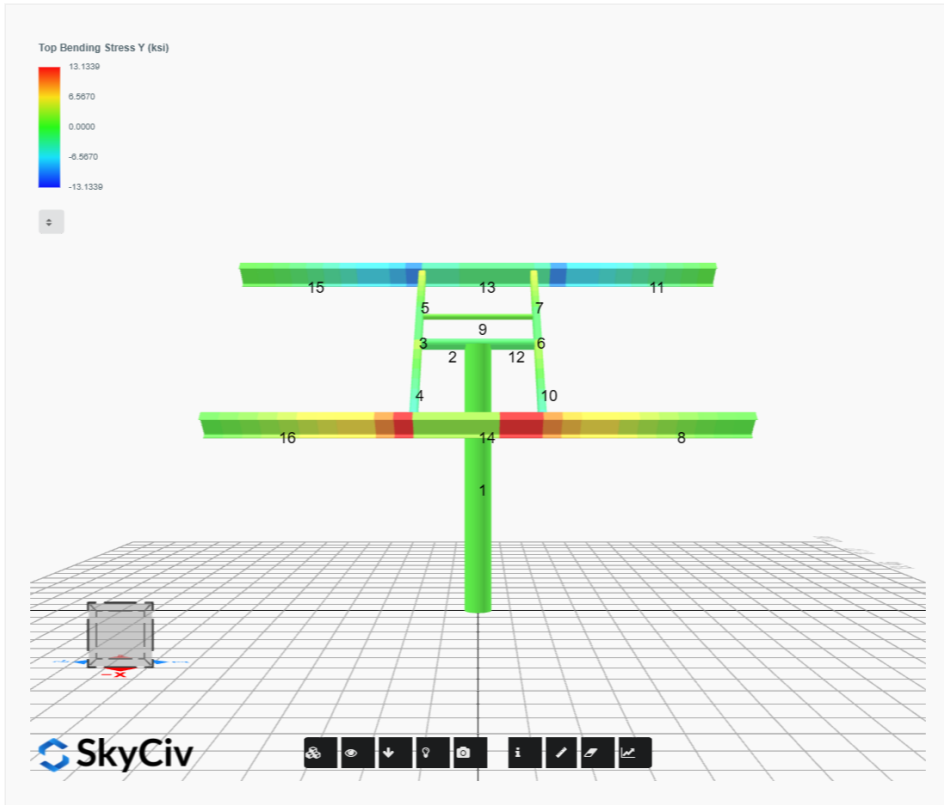

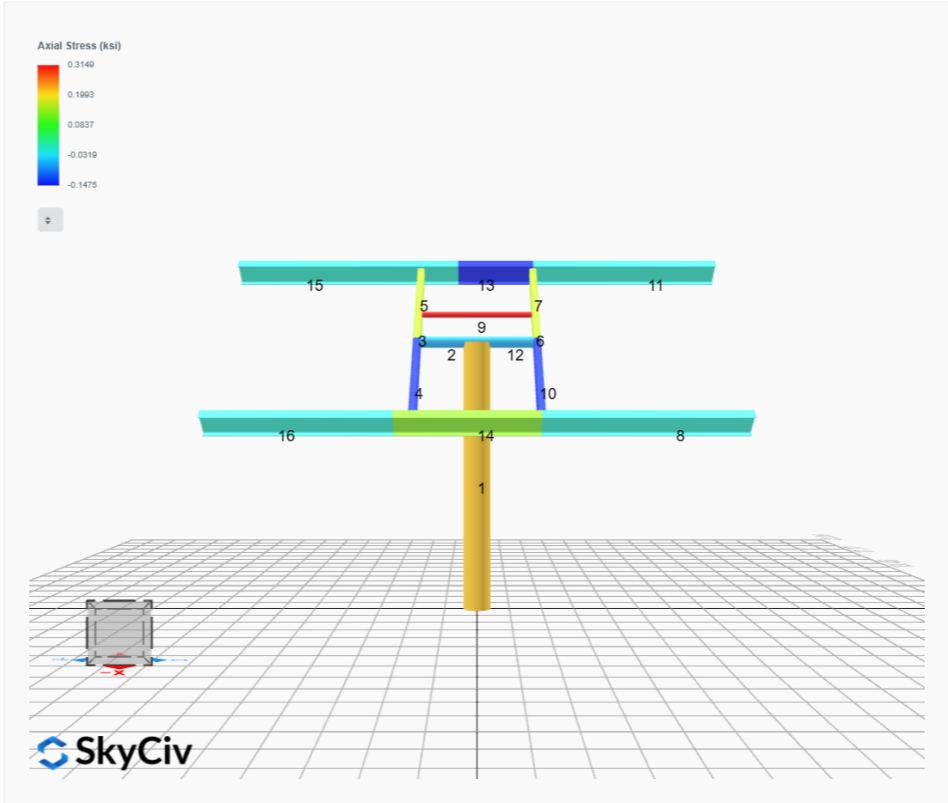

Reaction Forces for Foundation 1 (Node ID#1), (kip, kip-ft)

ASD Load Combination Results

Name	Fx	Fy	Fz	Mx	My	Mz
ULS: 1. D	-0.0000	2.1888	-0.0000	0.0000	-0.0000	0.0244
ULS: 2. D + L	-0.0000	2.1888	-0.0000	0.0000	-0.0000	0.0244
ULS: 3. D + (S or Lr or R)	0.0000	4.9317	-0.0000	0.0000	-0.0000	0.0321
ULS: 3. D + (S or Lr or R)	-0.0000	2.1888	-0.0000	0.0000	-0.0000	0.0244
ULS: 4. D + 0.75L + 0.75(S or Lr or R)	0.0000	4.2459	-0.0000	0.0000	-0.0000	0.0301
ULS: 4. D + 0.75L + 0.75(S or Lr or R)	-0.0000	2.1888	-0.0000	0.0000	-0.0000	0.0244
ULS: 5b. D + 0.7E	-0.0000	2.1888	-0.0000	0.0000	-0.0000	0.0244
ULS: 6b. D + 0.75L + 0.75(0.7)E + 0.75S	0.0000	4.2459	-0.0000	0.0000	-0.0000	0.0301
ULS: 8. 0.6D + 0.7E	-0.0000	1.3133	-0.0000	0.0000	-0.0000	0.0146
ULS: 5a. D + 0.6W_Wind downforce Case A only	-3.9059	6.0947	0.0000	0.0000	-0.0000	36.2688
ULS: 5a. D + 0.6W_Wind downforce Case B only	-3.9059	6.0947	0.0000	0.0000	-0.0000	36.2688
ULS: 5a. D + 0.6W_Wind uplift Case A only	2.8255	-0.6367	-0.0000	0.0000	-0.0000	-24.1247
ULS: 5a. D + 0.6W_Wind uplift Case B only	2.4931	-0.3043	-0.0000	0.0000	-0.0000	-29.0828
ULS: 6a. D + 0.75L + 0.75(0.6)W + 0.75(S or Lr or R)_Wind downforce Case A only	-2.9294	7.1754	-0.0000	0.0000	-0.0000	27.2135
ULS: 6a. D + 0.75L + 0.75(0.6)W + 0.75(S or Lr or R)_Wind downforce Case B only	-2.9294	7.1754	-0.0000	0.0000	-0.0000	27.2135
ULS: 6a. D + 0.75L + 0.75(0.6)W + 0.75(S or Lr or R)_Wind uplift Case A only	2.1192	2.1268	-0.0000	0.0000	-0.0000	-18.0816
ULS: 6a. D + 0.75L + 0.75(0.6)W + 0.75(S or Lr or R)_Wind uplift Case B only	1.8698	2.3761	-0.0000	0.0000	-0.0000	-21.8002
ULS: 6a. D + 0.75L + 0.75(0.6)W + 0.75(S or Lr or R)_Wind downforce Case A only	-2.9294	5.1182	0.0000	0.0000	-0.0000	27.2077
ULS: 6a. D + 0.75L + 0.75(0.6)W + 0.75(S or Lr or R)_Wind downforce Case B only	-2.9294	5.1182	0.0000	0.0000	-0.0000	27.2077
ULS: 6a. D + 0.75L + 0.75(0.6)W + 0.75(S or Lr or R)_Wind uplift Case A only	2.1192	0.0697	-0.0000	0.0000	-0.0000	-18.0874
ULS: 6a. D + 0.75L + 0.75(0.6)W + 0.75(S or Lr or R)_Wind uplift Case B only	1.8698	0.3190	-0.0000	0.0000	-0.0000	-21.8060
ULS: 7. 0.6D + 0.6W_Wind downforce Case A only	-3.9059	5.2192	0.0000	0.0000	-0.0000	36.2591
ULS: 7. 0.6D + 0.6W_Wind downforce Case B only	-3.9059	5.2192	0.0000	0.0000	-0.0000	36.2591
ULS: 7. 0.6D + 0.6W_Wind uplift Case A only	2.8255	-1.5122	-0.0000	0.0000	-0.0000	-24.1344
ULS: 7. 0.6D + 0.6W_Wind uplift Case B only	2.4931	-1.1798	-0.0000	0.0000	-0.0000	-29.0926

Worst Case Reactions LRFD

These calculations are taken directly from the FEA via SkyCiv and are used in the Concrete Checks of the Foundation Module.
Note: Worst case values are assumed as downforce wind load cases.

Result	Value (kip, kip-ft)
Axial	10.5078
Shear X	-6.5098
Shear Z	0.0000
Moment X	0.0000
Moment Y (Twist)	0.0000
Moment Z	60.6944

Worst Case Reactions ASD

These results are taken from the worst case values in the above table and are used in the Soil Checks in the Foundation Module.
Note: Worst case values are assumed as downforce wind load cases.

Result	Value (kip, kip-ft)
Axial	7.1754
Shear X	-3.9059
Shear Z	-0.0000
Moment X	0.0000
Moment Y (Twist)	0.0000
Moment Z	36.2688

Project Details

Design Code: AISC 360-16 LRFD
 Provision: LRFD
 Country: United States

User Name: sales@mtsolar.us
 Project Name: MTSOLAR_E1E0CG8K9BKF
 Unit System: imperial



Design Input Information

Design Factors			
Φ_t	Φ_c	Φ_b	Φ_v
0.9	0.9	0.9	0.9

Design Materials			
ID	E (ksi)	F _y (ksi)	F _u (ksi)
1	29000	50	65

Section Dimensions

ID	Name	d (in)	t _w (in)				
3	2in Pipe Sch 120	2.38	0.25				
6	4in Pipe Sch 120	4.50	0.44				
11	10in Pipe Sch 40	10.75	0.36				

ID	Name	d (in)	b (in)	t _w (in)	t _b (in)	r (in)	
17	HSS5x3x1/4	5.00	3.00	0.23	0.23	0.23	

ID	Name	d (in)	t _w (in)	b _t (in)	b _b (in)	t _t (in)	t _b (in)	r (in)
20	W10x12	9.87	0.19	3.96	3.96	0.21	0.21	0.30

Section Properties								
ID	Name	A (in ²)	J (in ⁴)	I _{yp} (in ⁴)	I _{zp} (in ⁴)	I _w (in ⁶)	S _{yp} (in ³)	S _{zp} (in ³)
3	2in Pipe Sch 120	1.67	1.91	0.96	0.96	0.00	1.13	1.13
6	4in Pipe Sch 120	5.58	23.29	11.64	11.64	0.00	7.24	7.24

10	151.65	145.15	20.17	14.14	54.12	28.95
11	159.30	34.37	46.90	6.46	56.26	44.91
12	251.01	248.88	27.16	27.16	75.30	75.30
13	159.30	116.35	31.48	6.46	56.26	44.91
14	159.30	116.35	30.87	6.46	56.26	44.91
15	159.30	34.37	46.90	6.46	56.26	44.91
16	159.30	34.37	46.90	6.46	56.26	44.91

Design Ratio

Member ID	P	M _z	M _y	V _y	V _z	(P,M _z ,M _y)	Worst LC	KL/r	δ	Status
1	0.026	0.411	0.000	0.040	0.000	0.424	#13	0.305	Not Required	Pass
2	0.004	0.308	0.231	0.067	0.043	0.541	#13	0.036	Not Required	Pass
3	0.008	0.567	0.039	0.057	0.001	0.591	#13	0.046	Not Required	Pass
4	0.008	0.511	0.152	0.051	0.032	0.563	#13	0.082	Not Required	Pass
5	0.008	0.352	0.157	0.056	0.041	0.374	#13	0.076	Not Required	Pass
6	0.008	0.567	0.039	0.057	0.001	0.591	#13	0.046	Not Required	Pass
7	0.008	0.352	0.157	0.056	0.041	0.374	#13	0.076	Not Required	Pass
8	0.000	0.077	0.227	0.027	0.014	0.289	#21	Not Required	Not Required	Pass
9	0.017	0.041	0.046	0.001	0.000	0.091	#13	0.206	Not Required	Pass
10	0.008	0.511	0.152	0.051	0.032	0.563	#13	0.082	Not Required	Pass
11	0.000	0.085	0.227	0.030	0.014	0.293	#21	Not Required	Not Required	Pass
12	0.004	0.308	0.231	0.067	0.043	0.541	#13	0.036	Not Required	Pass
13	0.007	0.254	0.426	0.041	0.019	0.610	#21	0.204	Not Required	Pass
14	0.008	0.234	0.426	0.037	0.019	0.598	#21	0.204	Not Required	Pass
15	0.000	0.085	0.227	0.030	0.014	0.293	#21	Not Required	Not Required	Pass
16	0.000	0.077	0.227	0.027	0.014	0.289	#21	Not Required	Not Required	Pass

Definitions

Φ_t	Safety factor for tensile
Φ_c	Safety factor for compression
Φ_b	Safety factor for flexure
Φ_v	Safety factor for shear
E	Modulus of elasticity
F _y	Specified minimum yield stress
F _u	Specified minimum tensile strength
A	Cross-sectional area
J	Torsional constant
I _{yp}	Moment of inertia about the Y axes
I _{zp}	Moment of inertia about the Z axes
I _w	Warping constant
S _{yp}	Plastic section modulus about the Y axis
S _{zp}	Plastic section modulus about the Z axis
KL	Effective length
C _b	Buckling modification factor (from all load combinations)
L _b	Length between braced points
LST	Limited slenderness for tension
LSC	Limited slenderness for compression
LD	Limited deflection
P _n	Nominal axial strength (tension/compression)
M _n	Nominal flexural strength (about Z/Y axis)
V _n	Nominal shear strength (along Z/Y axis)
P	Design ratio in case of axial force
M _z	Design ratio in case of bending about Z axis
M _y	Design ratio in case of bending about Y axis
V _y	Design ratio in case of shear along Y axis
V _z	Design ratio in case of shear along Z axis
(P,M _z ,M _y)	Design ratio in case of axial force and bending action
KL/r	Design ratio in case of section slenderness
δ	Design ratio in case of member deflection
OK	Capacity is provided

ON
NG

Capacity is provided
Capacity is not provided

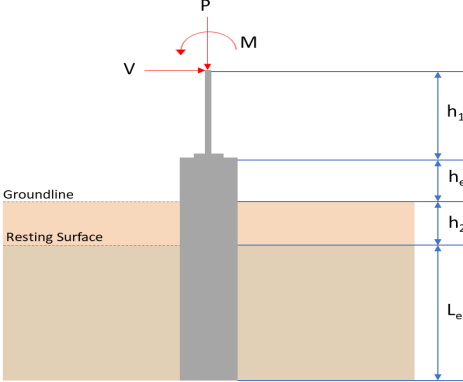
REFERENCES	CALCULATIONS	RESULTS																										
	<p>SkyCiv Foundation Design Pile Foundation</p> <p>Design Information : Design code : IBC 2021 (International Building Code) Unit System : Imperial</p>																											
	<p>Pile Input</p>  <p>Geometry Pile shape: rectangular $b = 48$ in - Pile width $D = 48$ in - Pile depth $L = 6.75$ ft - Total pile length $h_1 = 0$ ft - Lateral load height from the top of the pile, $h_2 = 0$ ft - Depth to resting surface $h_e = 0$ ft - Length of pile above the ground</p> <p>Tabulation of Soil Parameters</p> <table border="1" data-bbox="416 1102 1193 1191"> <thead> <tr> <th>Layer</th> <th>Label</th> <th>Allowable Bearing Pressure (q_a) (psf)</th> <th>Allowable Lateral Pressure (R) (psf/ft)</th> </tr> </thead> <tbody> <tr> <td>1</td> <td>Sand, silty sand, clayey sand, silty gravel & clayey gravel</td> <td>2000.000</td> <td>150.000</td> </tr> </tbody> </table> <p>Tabulation of Loads</p> <table border="1" data-bbox="676 1288 933 1458"> <thead> <tr> <th>Load Component</th> <th>ASD</th> <th>LRFD</th> </tr> </thead> <tbody> <tr> <td>P (kip)</td> <td>7.175</td> <td>10.508</td> </tr> <tr> <td>V_x (kip)</td> <td>-3.906</td> <td>-6.510</td> </tr> <tr> <td>V_z (kip)</td> <td>0.000</td> <td>0.000</td> </tr> <tr> <td>M_x (kipft)</td> <td>0.000</td> <td>0.000</td> </tr> <tr> <td>M_z (kipft)</td> <td>36.269</td> <td>60.694</td> </tr> </tbody> </table> <p>Material Properties $f'_{ck} = 3$ ksi - Concrete strength,</p>	Layer	Label	Allowable Bearing Pressure (q_a) (psf)	Allowable Lateral Pressure (R) (psf/ft)	1	Sand, silty sand, clayey sand, silty gravel & clayey gravel	2000.000	150.000	Load Component	ASD	LRFD	P (kip)	7.175	10.508	V_x (kip)	-3.906	-6.510	V_z (kip)	0.000	0.000	M_x (kipft)	0.000	0.000	M_z (kipft)	36.269	60.694	
Layer	Label	Allowable Bearing Pressure (q_a) (psf)	Allowable Lateral Pressure (R) (psf/ft)																									
1	Sand, silty sand, clayey sand, silty gravel & clayey gravel	2000.000	150.000																									
Load Component	ASD	LRFD																										
P (kip)	7.175	10.508																										
V_x (kip)	-3.906	-6.510																										
V_z (kip)	0.000	0.000																										
M_x (kipft)	0.000	0.000																										
M_z (kipft)	36.269	60.694																										
	<p>Required depth to resist lateral loads (ASD) H - Point of application of the lateral load</p> $H = h_1 + h_2 + h_e$ $H = (0 \text{ ft}) + (0 \text{ ft}) + (0 \text{ ft})$ $H = 0 \text{ ft}$ <p>Considering x-direction: H_o - Lateral force per length of pile,</p> $H_o = \frac{V_x}{1.57 D}$ $H_o = \frac{(-3.906 \text{ kip})}{1.57 \times (48 \text{ in})}$ $H_o = -0.62197 \text{ kip/ft}$ <p>M_o - Moment per length of pile,</p> $M_o = \frac{M_z + (V_x H)}{1.57 D}$																											

$$M_o = \frac{(36.269 \text{ kipft}) + ((-3.906 \text{ kip}) \times (0 \text{ ft}))}{1.57 \times (48 \text{ in})}$$

$$M_o = 5.7753 \text{ kipft/ft}$$

Required depth of embedment in earth:

$$L_x^3 - \left(14.14 \times \frac{H_o \times L_x}{R}\right) - \left(18.85 \times \frac{M_o}{R}\right) = 0$$

Solving the cubic equation:

$$L_{e,x} = 6.1494 \text{ ft} - \text{Required depth in x-direction,}$$

Considering z-direction:

$$L_{e,z} = 0 \text{ ft} - \text{Required depth in z-direction,}$$

Minimum embedded depth required:

$L_{e,req}$ - Depth of pile required,

$$L_{e,req} = \text{MAX}[L_{e,x}, L_{e,z}]$$

$$L_{e,req} = \text{MAX}[(6.1494 \text{ ft}), (0 \text{ ft})]$$

$$L_{e,req} = 6.149 \text{ ft}$$

L_e - Actual embedded length of pile,

$$L_e = L - h_e - h_2$$

$$L_e = (6.75 \text{ ft}) - (0 \text{ ft}) - (0 \text{ ft})$$

$$L_e = 6.75 \text{ ft}$$

Ratio - Embedded depth

$$\text{Ratio} = \frac{L_{e,req}}{L_e}$$

$$\text{Ratio} = \frac{(6.149 \text{ ft})}{(6.75 \text{ ft})}$$

$$\text{Ratio} = 0.91096$$

Status: **PASS**
Ratio: **0.910**

End-bearing Capacity (ASD)

A - Pile cross-section area

$$A = b D$$

$$A = (48 \text{ in}) \times (48 \text{ in})$$

$$A = 16 \text{ ft}^2$$

q - End-bearing pressure

$$q = \frac{P_v}{A}$$

$$q = \frac{(7.175 \text{ kip})}{(16 \text{ ft}^2)}$$

$$q = 0.44844 \text{ kip/ft}^2$$

Check bearing capacity ratio:

Ratio - Capacity

$$\text{Ratio} = \frac{q}{q_o}$$

$$\text{Ratio} = \frac{(0.44844 \text{ kip/ft}^2)}{(2000 \text{ psf})}$$

$$\text{Ratio} = 0.22422$$

Status: **PASS**
Ratio: **0.220**

Czerniak

Lateral Soil Pressure (ASD):

L/D - Length to least lateral dimension ratio,

$$L/D = \frac{L}{D}$$

$$L/D = \frac{(6.75 \text{ ft})}{(48 \text{ in})}$$

$$L/D = 1.6875$$

Since $L/D \leq 10$,

Pile is short.

Considering x-direction:

$H_o = -0.62197$ kip/ft - Lateral force per length of pile,

$M_o = 5.7753$ kipft/ft - Overturning moment per length of pile,

a - Distance from resting surface to pivot point,

$$a = \frac{(4 M_o L_e) + (3 H_o L_e^2)}{(6 M_o) + (4 H_o L_e)}$$

$$a = \frac{(4 \times (5.7753 \text{ kipft/ft}) \times (6.75 \text{ ft})) + (3 \times (-0.62197 \text{ kip/ft}) \times (6.75 \text{ ft})^2)}{(6 \times (5.7753 \text{ kipft/ft})) + (4 \times (-0.62197 \text{ kip/ft}) \times (6.75 \text{ ft}))}$$

$$a = 4.6836 \text{ ft}$$

p - Earth pressure against the pile at distance $a/2$ from resting surface,

$$p = \frac{0.75 [(4 M_o) + (3 H_o L_e)]^2}{L_e^2 [(3 M_o) + (2 H_o L_e)]}$$

$$p = \frac{0.75 \times [(4 \times (5.7753 \text{ kipft/ft})) + (3 \times (-0.62197 \text{ kip/ft}) \times (6.75 \text{ ft}))]^2}{(6.75 \text{ ft})^2 \times [(3 \times (5.7753 \text{ kipft/ft})) + (2 \times (-0.62197 \text{ kip/ft}) \times (6.75 \text{ ft}))]}$$

$$p = 0.20349 \text{ kip/ft}^2$$

s - Earth pressure against the pile at distance L_e ,

$$s = \frac{6 [(2 M_o) + (H_o L_e)]}{L_e^2}$$

$$s = \frac{6 \times [(2 \times (5.7753 \text{ kipft/ft})) + ((-0.62197 \text{ kip/ft}) \times (6.75 \text{ ft}))]}{(6.75 \text{ ft})^2}$$

$$s = 0.96821 \text{ kip/ft}^2$$

Check lateral soil pressure capacity:

p_a - Allowable lateral soil pressure at depth $a/2$,

$$p_a = R \frac{a}{2}$$

$$p_a = (150 \text{ psf/ft}) \times \frac{(4.6836 \text{ ft})}{2}$$

$$p_a = 0.35127 \text{ kip/ft}^2$$

Ratio - Lateral soil capacity

$$\text{Ratio} = \frac{p}{p_a}$$

$$\text{Ratio} = \frac{(0.20349 \text{ kip/ft}^2)}{(0.35127 \text{ kip/ft}^2)}$$

$$\text{Ratio} = 0.57929$$

p_s - Allowable lateral soil pressure at depth L_e ,

$$p_s = R L_e$$

$$p_s = (150 \text{ psf/ft}) \times (6.75 \text{ ft})$$

$$p_s = 1.0125 \text{ kip/ft}^2$$

Ratio - Lateral soil capacity

$$\text{Ratio} = \frac{s}{p_s}$$

$$\text{Ratio} = \frac{(0.96821 \text{ kip/ft}^2)}{(1.0125 \text{ kip/ft}^2)}$$

$$\text{Ratio} = 0.95625$$

Status: **PASS**
Ratio: **0.580**

Status: **PASS**
Ratio: **0.960**

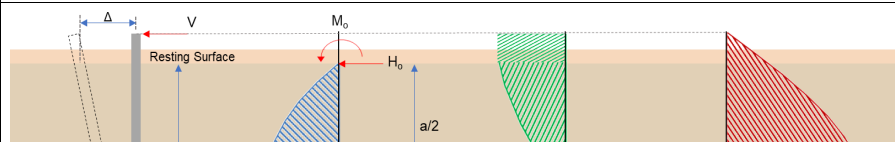



Shear force and Bending moment (x-direction, LRFD)

H_o - Lateral force per length of pile,

$$H_o = \frac{V_x}{1.57 D}$$

$$H_o = \frac{(-6.51 \text{ kip})}{1.57 \times (48 \text{ in})}$$

$$H_o = -1.0366 \text{ kip/ft}$$

M_o - Moment per length of pile,

$$M_o = \frac{M_x + (V_x H)}{1.57 D}$$

$$M_o = \frac{(60.694 \text{ kipft}) + ((-6.51 \text{ kip}) \times (0 \text{ ft}))}{1.57 \times (48 \text{ in})}$$

$$M_o = 9.6646 \text{ kipft/ft}$$

E - Distance from lateral load to resisting surface,

$$E = \frac{M_o}{H_o}$$

$$E = \frac{(9.6646 \text{ kipft/ft})}{(-1.0366 \text{ kip/ft})}$$

$$E = 9.3232 \text{ ft}$$

a - Distance from resting surface to pivot point,

$$a = \frac{(4 M_o L_c) + (3 H_o L_c^2)}{(6 M_o) + (4 H_o L_c)}$$

$$a = \frac{(4 \times (9.6646 \text{ kipft/ft}) \times (6.75 \text{ ft})) + (3 \times (-1.0366 \text{ kip/ft}) \times (6.75 \text{ ft})^2)}{(6 \times (9.6646 \text{ kipft/ft})) + (4 \times (-1.0366 \text{ kip/ft}) \times (6.75 \text{ ft}))}$$

$$a = 4.6831 \text{ ft}$$

V_{max} - Max shear force located at depth a ,

$$V_{max} = (H_o D) \left[1 - \left[3 \left(\frac{4 E}{L_c} + 3 \right) \left(\frac{a}{L_c} \right)^2 \right] + \left[4 \left(\frac{3 E}{L_c} + 2 \right) \left(\frac{a}{L_c} \right)^3 \right] \right]$$

$$V_{max} = ((-1.0366 \text{ kip/ft}) \times (48 \text{ in})) \times \left[1 - \left[3 \times \left(\frac{4 \times (9.3232 \text{ ft})}{(6.75 \text{ ft})} + 3 \right) \times \left(\frac{(4.6831 \text{ ft})}{(6.75 \text{ ft})} \right)^2 \right] + \left[4 \times \left(\frac{3 \times (9.3232 \text{ ft})}{(6.75 \text{ ft})} + 2 \right) \times \left(\frac{(4.6831 \text{ ft})}{(6.75 \text{ ft})} \right)^3 \right] \right]$$

$$V_{max} = 12.868 \text{ kip}$$

M_{max} - Max bending moment located at depth $a/2$,

$$M_{max} = (H_o D L_c) \left[\left(\frac{E}{L_c} + \frac{a}{2 L_c} \right) - \left[\left(\frac{4 E}{L_c} + 3 \right) \left(\frac{a}{2 L_c} \right)^3 \right] + \left[\left(\frac{3 E}{L_c} + 2 \right) \left(\frac{a}{2 L_c} \right)^4 \right] \right]$$

$$M_{max} = ((-1.0366 \text{ kip/ft}) \times (48 \text{ in}) \times (6.75 \text{ ft})) \times \left[\left(\frac{(9.3232 \text{ ft})}{(6.75 \text{ ft})} + \frac{(4.6831 \text{ ft})}{2 \times (6.75 \text{ ft})} \right) - \left[\left(\frac{4 \times (9.3232 \text{ ft})}{(6.75 \text{ ft})} + 3 \right) \times \left(\frac{(4.6831 \text{ ft})}{2 \times (6.75 \text{ ft})} \right)^3 \right] + \left[\left(\frac{3 \times (9.3232 \text{ ft})}{(6.75 \text{ ft})} + 2 \right) \times \left(\frac{(4.6831 \text{ ft})}{2 \times (6.75 \text{ ft})} \right)^4 \right] \right]$$

$$M_{max} = 40.898 \text{ kipft}$$

Minimum Reinforcement Check (LRFD)

Parameters:

$f'_{ck} = 3 \text{ ksi}$ - Concrete strength,
 $f_{yk} = 60 \text{ ksi}$ - Longitudinal reinforcement strength,
 $\phi = 0.65$ - Reduction factor for axial strength,
 $\alpha = 0.8$ - Alpha factor for axial strength,
 $A_g = 2304 \text{ in}^2$ - Gross area of concrete,

Table 22.4.2.1

Longitudinal reinforcement:

Required reinforcement due to axial load, $A_{st,required}$

22.4.2.2, 10.6.1.1

$A_{st,required}$

$$A_{st,required} = \text{Min} \left[\frac{\frac{P}{\phi \alpha} - (0.85 f'_{ck} A_g)}{f_{yk} - (0.85 f'_{ck})}, (0.08 A_g) \right]$$

$$A_{st,required} = \text{Min} \left[\frac{\frac{(10.508 \text{ kip})}{(0.65) \times (0.8)} - (0.85 \times (3 \text{ ksi}) \times (2304 \text{ in}^2))}{(60 \text{ ksi}) - (0.85 \times (3 \text{ ksi}))}, (0.08 \times (2304 \text{ in}^2)) \right]$$

$$A_{st,required} = -101.91 \text{ in}^2$$

A_{min} - Governing minimum reinforcement area,

$$A_{min} = \text{Max} [A_{st,required}, (0.0018 A_g)]$$

$$A_{min} = \text{Max} [(-101.91 \text{ in}^2), (0.0018 \times (2304 \text{ in}^2))]$$

$$A_{min} = 4.1472 \text{ in}^2$$

n_{rebar} - Required number of reinforcement,

$$n_{rebar} = \frac{A_{min}}{A_{rebar}}$$

$$n_{rebar} = \frac{(4.1472 \text{ in}^2)}{(0.3068 \text{ in}^2)}$$

$$n_{rebar} = 14$$

A_{st} - Actual total reinforcement area,

$$A_{st} = n_{rebar} \frac{\pi d_{bar}^2}{4}$$

$$A_{st} = (14) \times \frac{\pi \times (0.625 \text{ in})^2}{4}$$

$$A_{st} = 4.2951 \text{ in}^2$$

Ratio - Capacity

$$\text{Ratio} = \frac{A_{min}}{A_{st}}$$

$$\text{Ratio} = \frac{(4.1472 \text{ in}^2)}{(4.2951 \text{ in}^2)}$$

$$\text{Ratio} = 0.96556$$

Status: **PASS**
Ratio: **0.970**

25.2.3

s_{rebar} - Minimum spacing of reinforcement,

$$s_{rebar} = \text{Max} [1.5, (1.5 d_{bar})]$$

$$s_{rebar} = \text{Max} [1.5, (1.5 \times (0.625 \text{ in}))]$$

$$s_{rebar} = 1.5 \text{ in}$$

Ties:

25.7.2.2 Since longitudinal reinforcement is \leq No. 10: Use #3(0.375 in)

25.7.2.1

s_{ties} - Maximum spacing of ties,

$$s_{ties} = \text{Min} [(16 d_{bar}), (48 d_{ties}), \text{Min} (D, b)]$$

$$s_{ties} = \text{Min} [(16 \times (0.625 \text{ in})), (48 \times (0.375 \text{ in})), \text{Min} ((48 \text{ in}), (48 \text{ in}))]$$

$$s_{ties} = 10 \text{ in}$$

Summary:

Main reinforcement: **14 - #5 (0.625 in)**

Axial Compression Strength (ACI 318-19, LRFD)22.4.2.2 ϕP_N - Allowable axial compressive strength

$$\phi P_N = \phi 0.80 [(0.85 f'_{ck} [A_g - A_{st}]) + (f_{yk} A_{st})]$$

$$\phi P_N = (0.65) \times 0.80 \times [(0.85 \times (3 \text{ ksi}) \times [(2304 \text{ in}^2) - (4.2951 \text{ in}^2)]) + ((60 \text{ ksi}) \times (4.2951 \text{ in}^2))]$$

$$\phi P_N = 3183.4 \text{ kip}$$

Ratio - Capacity

$$\text{Ratio} = \frac{P}{\phi P_N}$$

$$\text{Ratio} = \frac{(10.508 \text{ kip})}{(3183.4 \text{ kip})}$$

$$\text{Ratio} = 0.0033009$$

Status: **PASS**
Ratio: **0.000****Shear Strength (ACI 318-19, LRFD)****Parameters:** $b_w = 48 \text{ in}$ - Effective width,22.5.2.2 d - Effective depth

$$d = 0.80 D$$

$$d = 0.80 \times (48 \text{ in})$$

$$d = 38.4 \text{ in}$$

22.5.5.1.3 λ_s - size effect modification factor

$$\lambda_s = \text{MIN} \left[\sqrt{\frac{2}{1 + \frac{d}{10}}}, 1 \right]$$

$$\lambda_s = \text{MIN} \left[\sqrt{\frac{2}{1 + \frac{(38.4 \text{ in})}{10}}}, 1 \right]$$

$$\lambda_s = 0.64282$$

The following variables were converted to be consistent with empirical formula $f'_{ck} = 3 \text{ ksi} \rightarrow 3000 \text{ psi}$,22.5.5.1.1 $V_{c,max}$ - Max shear strength of concrete

$$V_{c,max} = 5 \lambda_s \sqrt{f'_{ck}} b_w d$$

$$V_{c,max} = 5 \times (0.64282) \times \sqrt{(3000 \text{ psi})} \times (48 \text{ in}) \times (38.4 \text{ in})$$

$$V_{c,max} = 324.49 \text{ kip}$$

The following variables were converted to be consistent with empirical formula $f'_{ck} = 3 \text{ ksi} \rightarrow 3000 \text{ psi}$, $P = 10.508 \text{ kip} \rightarrow 10508 \text{ lbf}$,22.5.5.1.1(a) $V_{c,a}$ - Shear strength of concrete (a)

$$V_{c,a} = \left[2 \lambda_s \sqrt{f'_{ck}} + \frac{P}{6 A_g} \right] b_w d$$

$$V_{c,a} = \left[2 \times (0.64282) \times \sqrt{(3000 \text{ psi})} + \frac{(10508 \text{ lbf})}{6 \times (2304 \text{ in}^2)} \right] \times (48 \text{ in}) \times (38.4 \text{ in})$$

$$V_{c,a} = 131.2 \text{ kip}$$

The following variables were converted to be consistent with empirical formula $f'_{ck} = 3 \text{ ksi} \rightarrow 3000 \text{ psi}$,22.5.5.1.2 $V_{c,b}$ - Shear strength of concrete (b)

$$V_{c,b} = \left[2 \lambda_s \sqrt{f'_{ck}} + (0.05 f'_{ck}) \right] b_w d$$

$$V_{c,b} = \left[2 \times (0.64282) \times \sqrt{(3000 \text{ psi})} + (0.05 \times (3000 \text{ psi})) \right] \times (48 \text{ in}) \times (38.4 \text{ in})$$

$$V_{c,b} = 406.27 \text{ kip}$$

 V_c - Governing shear strength of concrete

$$V_c = \text{Min}[V_{c,max}, V_{c,a}, V_{c,b}]$$

$$V_c = \text{Min}[(324.49 \text{ kip}), (131.2 \text{ kip}), (406.27 \text{ kip})]$$

$$V_c = 131.2 \text{ kip}$$

<p>22.5.1.2</p>	<p>The following variables were converted to be consistent with empirical formula $f'_{ck} = 3 \text{ ksi} \rightarrow 3000 \text{ psi}$.</p> <p>$V_{s,a}$ - Shear strength of steel (a)</p> $V_{s,a} = 8 \sqrt{f'_{ck}} b_w d$ $V_{s,a} = 8 \times \sqrt{(3000 \text{ psi})} \times (48 \text{ in}) \times (38.4 \text{ in})$ $V_{s,a} = 807.65 \text{ kip}$ <p>A_v - Ties rebar area,</p> $A_v = \frac{\pi d_{ties}^2}{4}$ $A_v = \frac{\pi \times (0.375 \text{ in})^2}{4}$ $A_v = 0.11045 \text{ in}^2$ <p>22.5.8.5.3 $V_{s,b}$ - Shear strength of steel (b)</p> $V_{s,b} = \frac{2 A_v f_{ywk} d}{s_{ties}}$ $V_{s,b} = \frac{2 \times (0.11045 \text{ in}^2) \times (60 \text{ ksi}) \times (38.4 \text{ in})}{(10 \text{ in})}$ $V_{s,b} = 50.894 \text{ kip}$ <p>V_s - Governing shear strength of steel</p> $V_s = \text{MIN}[V_{s,a}, V_{s,b}]$ $V_s = \text{MIN}[(807.65 \text{ kip}), (50.894 \text{ kip})]$ $V_s = 50.894 \text{ kip}$ <p>22.5.1.1 ϕV_n - Allowable shear strength</p> $\phi V_n = \phi (V_c + V_s)$ $\phi V_n = (0.65) \times ((131.2 \text{ kip}) + (50.894 \text{ kip}))$ $\phi V_n = 118.36 \text{ kip}$ <p>Considering x-direction:</p> <p>$V_{max} = 12.868 \text{ kip}$ - Maximum shear force in the x-direction, Ratio - Capacity</p> $\text{Ratio} = \frac{V_{max}}{\phi V_n}$ $\text{Ratio} = \frac{(12.868 \text{ kip})}{(118.36 \text{ kip})}$ $\text{Ratio} = 0.10872$	<p>Status: PASS Ratio: 0.110</p>
<p>14.5.2.1b</p>	<p>Flexural Strength (ACI 318-19, LRFD)</p> <p>S_m - Section modulus</p> $S_m = \frac{b D^2}{6}$ $S_m = \frac{(48 \text{ in}) \times (48 \text{ in})^2}{6}$ $S_m = 18432 \text{ in}^3$ <p>$\lambda = 1$ - Concrete modification factor (Normal concrete), Allowable flexural strength: M_n shall be the lesser of:</p> <p>$\phi M_{n,1}$</p> $\phi M_{n,1} = \phi \times 5 \times \lambda \times \sqrt{f'_c} \times S_m$ $\phi M_{n,1} = 0.65 \times 5 \times 1 \times \sqrt{(3 \text{ ksi})} \times 18432.001 \text{ in}^3$ $\phi M_{n,1} = 273.423 \text{ kipft}$ <p>$\phi M_{n,2}$</p> $\phi M_{n,2} = 0.85 f'_c S_m$	

$$\phi M_{n,z} = \phi S_x F_y$$

$$\phi M_{n,z} = (0.65) \times 0.85 \times (3 \text{ ksi}) \times (18432 \text{ in}^3)$$

$$\phi M_{n,z} = 2545.9 \text{ kipft}$$

Therefore,

ϕM_n - Allowable flexural strength,

$$\phi M_n = \text{MIN}[\phi M_{n,1}, \phi M_{n,2}]$$

$$\phi M_n = \text{MIN}[(273.42 \text{ kipft}), (2545.9 \text{ kipft})]$$

$$\phi M_n = 273.42 \text{ kipft}$$

Considering x-direction:

$M_{max} = 40.898 \text{ kipft}$ - Maximum moment in the x-direction,

Ratio - Capacity

$$\text{Ratio} = \frac{M_{max}}{\phi M_n}$$

$$\text{Ratio} = \frac{(40.898 \text{ kipft})}{(273.42 \text{ kipft})}$$

$$\text{Ratio} = 0.14958$$

Status: **PASS**
Ratio: **0.150**