

Project Name: Theodosakis **Date:** Tue Jul 15 2025
Location: 136 W Deer Vista Ln, Heber City, UT 84032, USA **Number of Modules:** 15
Unique ID: 2P-17-6TOP-SD-24-L-3Hx5W-0986 **Number of Poles:** 2
Dealer: _____ **Date Sold:** _____

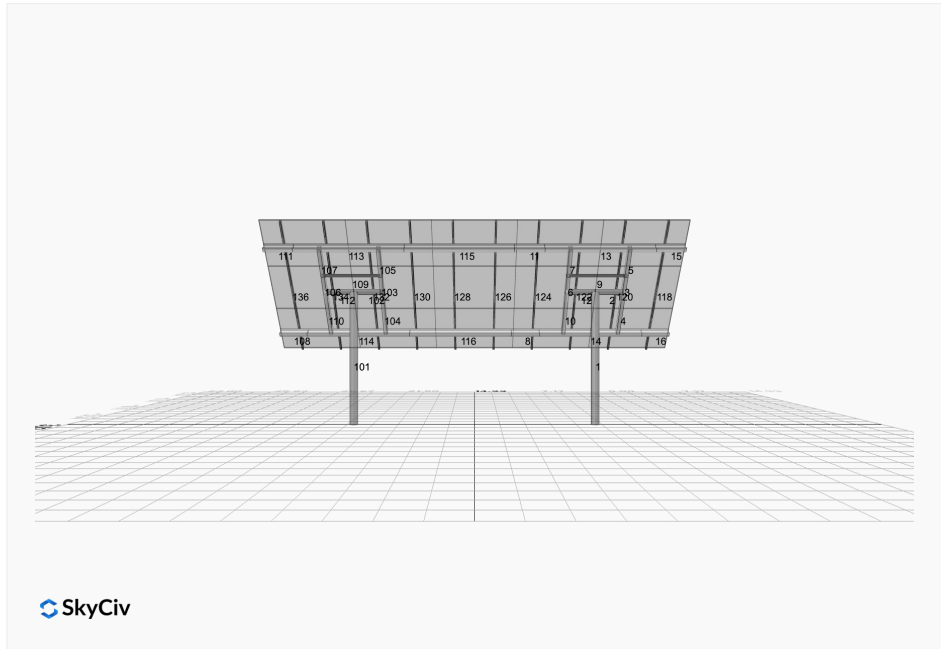

Array Dimensions N/S	11.29 ft
Array Dimensions E/W	28.67 ft
Winter Tilt Angle	50
Front Edge Clearance	5 ft

MT Solar Bill of Materials (2P-17-6TOP-SD-24-L-3Hx5W-0986)

Part	Short Description	BOM Qty
MTS-PC-6	6IN Pole Cap Assembly	2
MTS-HF-SD	H-Frame Assembly-SD	2
MTS-SD-Wing-24	24IN SD Wing	4
MTS-SD-Splice-57	57IN SD Splice	4
MTS-CLAMP-HOOK-4PK	Hook Clamp	5

Rail Bill of Materials

Part	Qty
Rails (135in)	10
Rail Attachment	20
Module Mid Clamp	20
Module End Clamp	20
Ground Lug	5

Site Details:

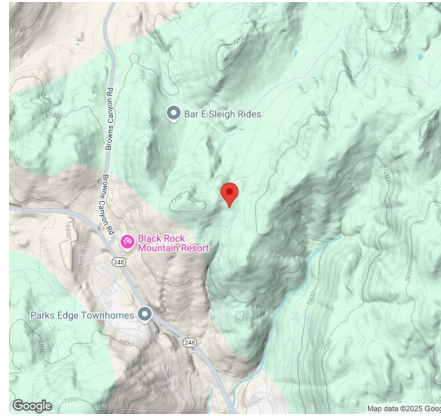

Site Address: 136 W Deer Vista Ln, Heber City, UT 84032, USA

Array Specification

Duty Classification:	SD
Module Width:	44.65 in
Module Length:	67.80in
Number of Rows:	3
Number of Columns:	5
Total Number of Modules:	15
Winter Tilt Angle:	50
Front Edge Clearance:	5
Total Array Height at Tilt:	13.65 ft
Total Frame Length:	28.50 ft
Module Info/Notes:	Hyundai 435W
Array Dimensions N/S:	11.29 ft
Array Dimensions E/W:	28.67 ft
Rail Length:	135.45 in
Rail Spacing:	2.87 ft

Support Specifications

Pole Size:	6in Pipe Sch 40
Pole Length above Grade:	9.32 ft
Number of Poles:	2
Pole Spacing:	17 ft

Foundation Specifications

Foundation Type:	Square
Foundation Dimensions:	48 x 48 in
Foundation Depth (below grade):	Pile 1: 5.25 ft Pile 2: 5.25 ft
Foundation Volume:	6.222 y ³

Site Info

Risk Category:	I
Exposure:	C
Soil Classification:	sand
Site Location:	136 W Deer Vista Ln, Heber City, UT 84032, USA
Wind Speed:	115 mph
Snow Load:	60 psf

Design Disclaimer

This software should be used for preliminary designs and should not be used as a final design unless reviewed, verified and designed by a qualified structural engineer.

AutoDesigner Input

```
{ "product_type": "Beam", "designer_name": "John Conde", "designer_email": "john@alpenglenergy.com", "designer_phone": "2024124357", "project_id": "Theodosakis", "site_address": "136 W Deer Vista Ln, Heber City, UT 84032, USA", "module_info": "Hyundai 435W", "module_width": 44.65, "module_length": 67.8, "number_rows": 3, "number_columns": 5, "pole_mount_section": "4_40", "core_pipe_width": 65, "core_pipe_section": "2_40", "adjuster_section": "2_40", "core_beam_height": 65, "core_beam_section": "HSS3x2x1/8", "main_pipe_section": "2_12GA", "pole_spacing": 15, "tilt_angle": 50, "ground_clearance": 5, "risk_category": "I", "exposure_category": "C", "frame_duty_override": "auto", "pole_override": "auto", "soil_type": "sand", "customer_foundation_override": "48_Square", "foundation_type": "Square", "foundation_size": 48, "check_rails": false, "wind_speed_override": 115, "snow_load_override": 60, "direct_snow_load": false, "add_angle_brace": false }
```

Design Notes:

- AISC Deflection checks are set to L/1 due to structure design intent
- Foundation Soil Parameters used in this Autodesign are all estimates, proper geotechnical reports are required to confirm soil profiles
- Wind speeds, snow loads and other site specific results are based on ASCE 7 2016
- Steel frame design checks are based on AISC 360 2016 (LRFD)
- Foundation Design and Sizing is approximate only

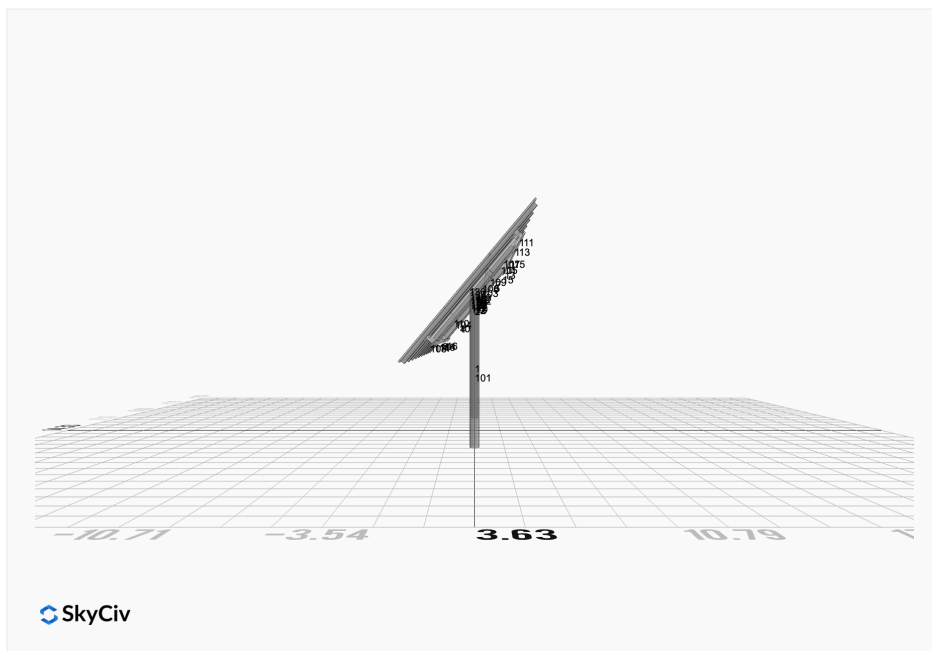
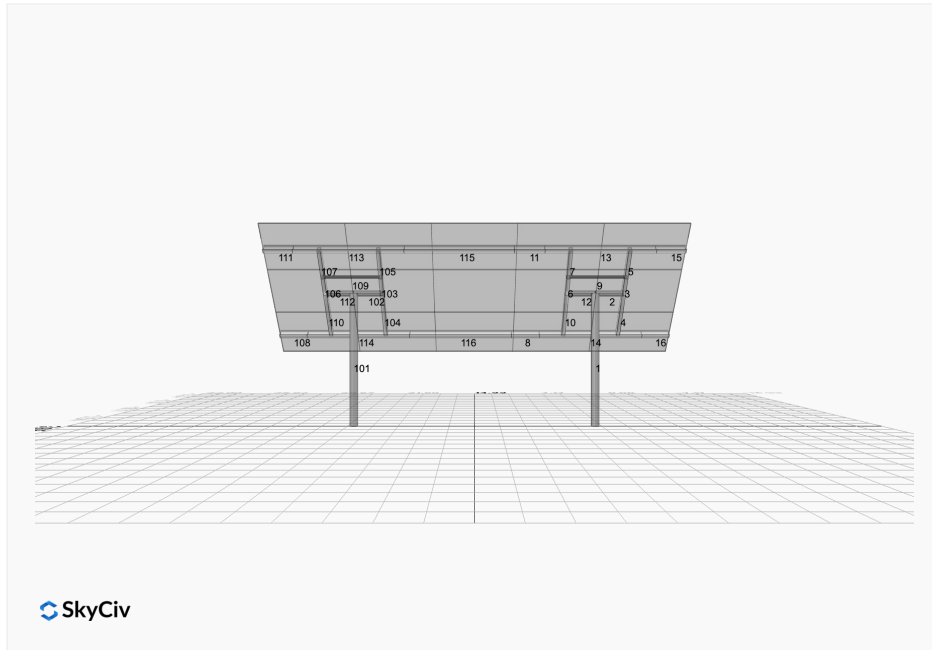

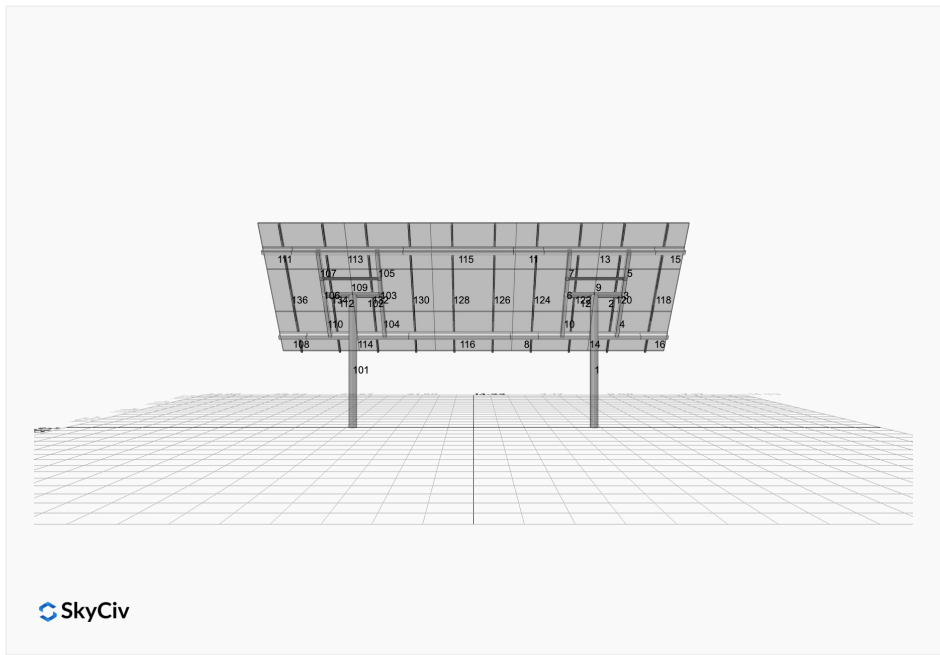
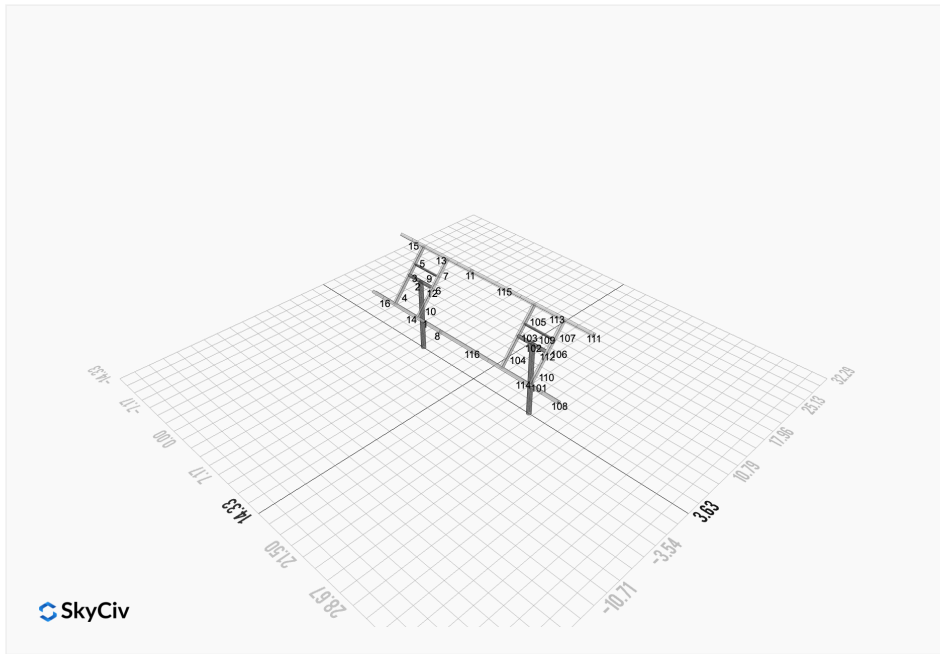
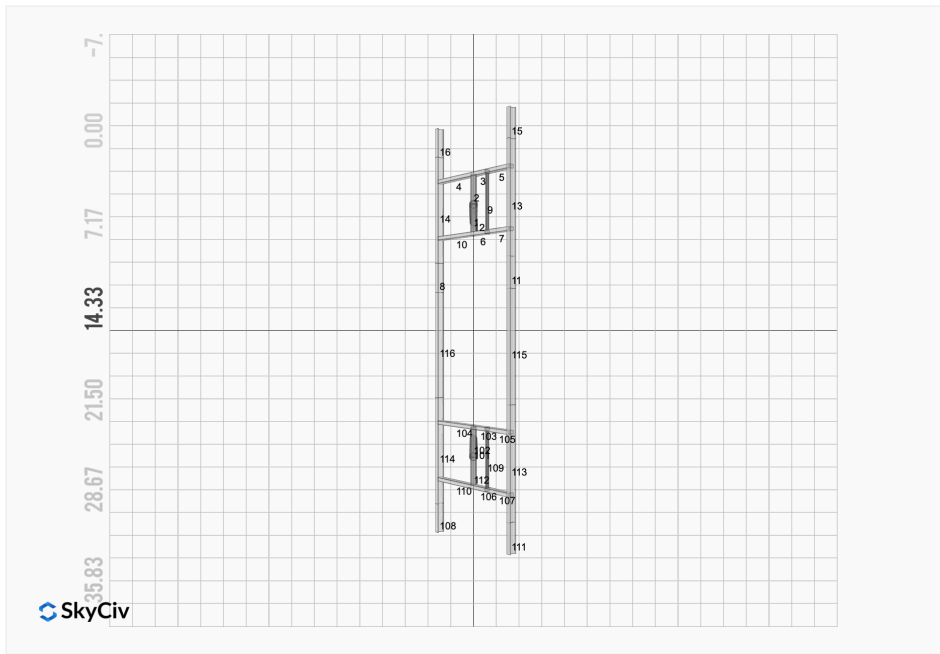

FEM Results (Envelope Worst Case for each member)

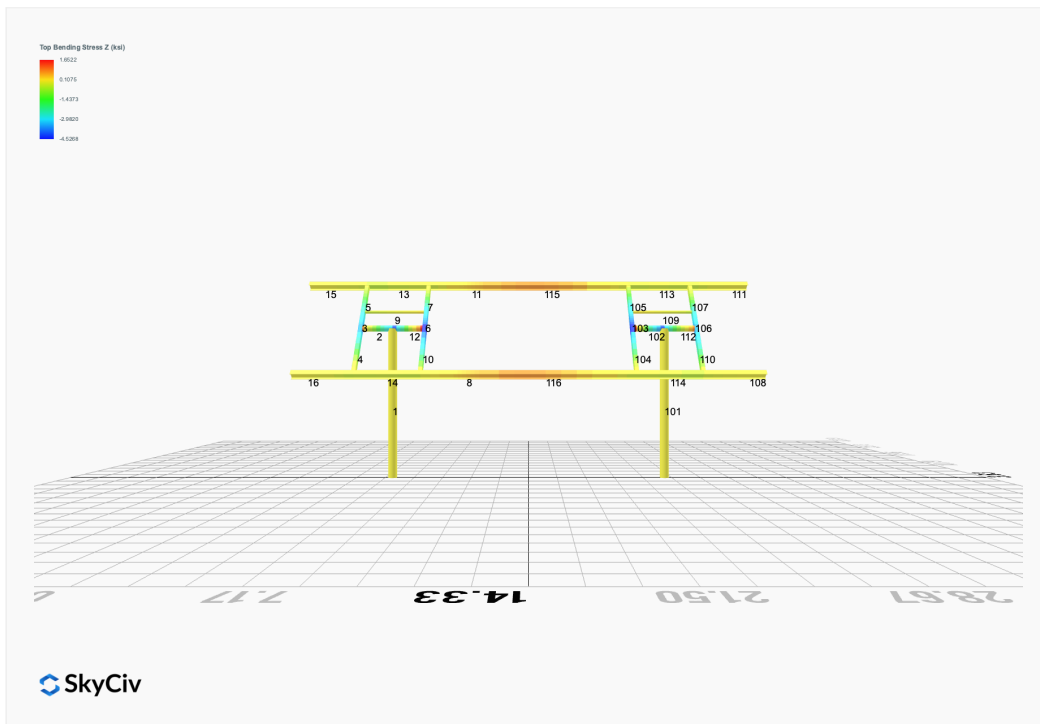
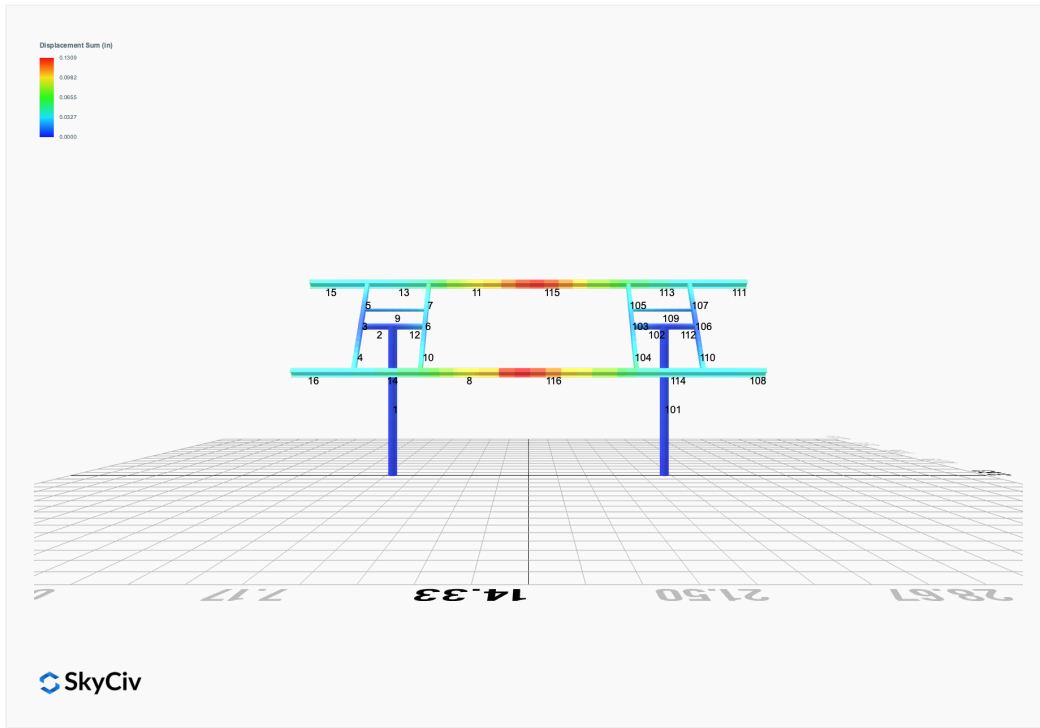

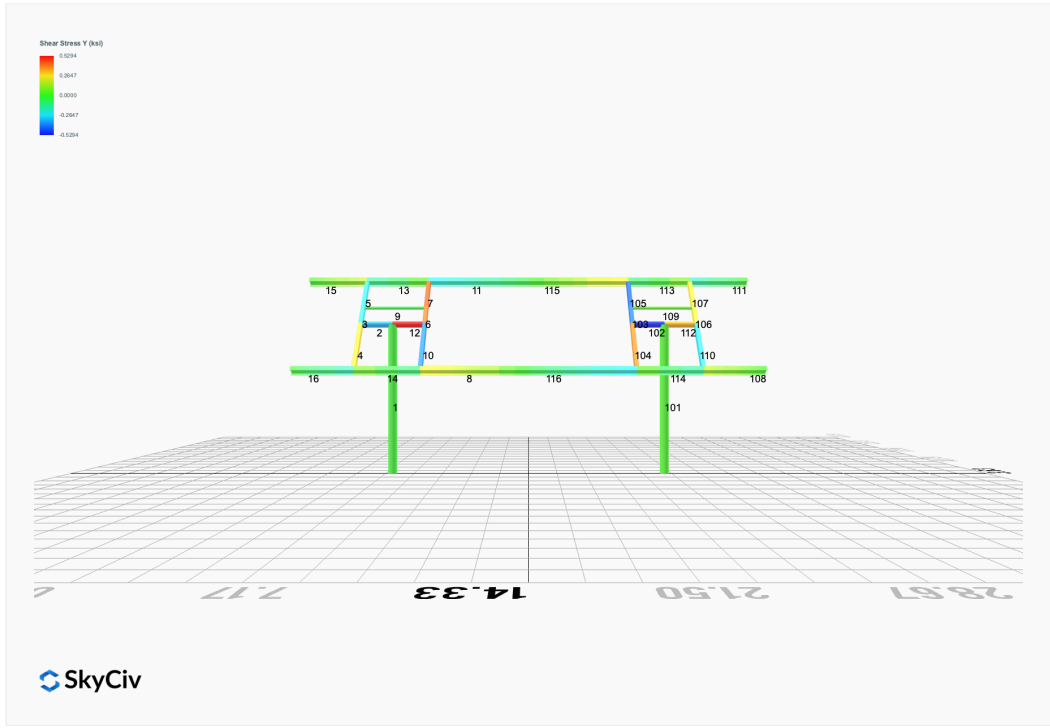
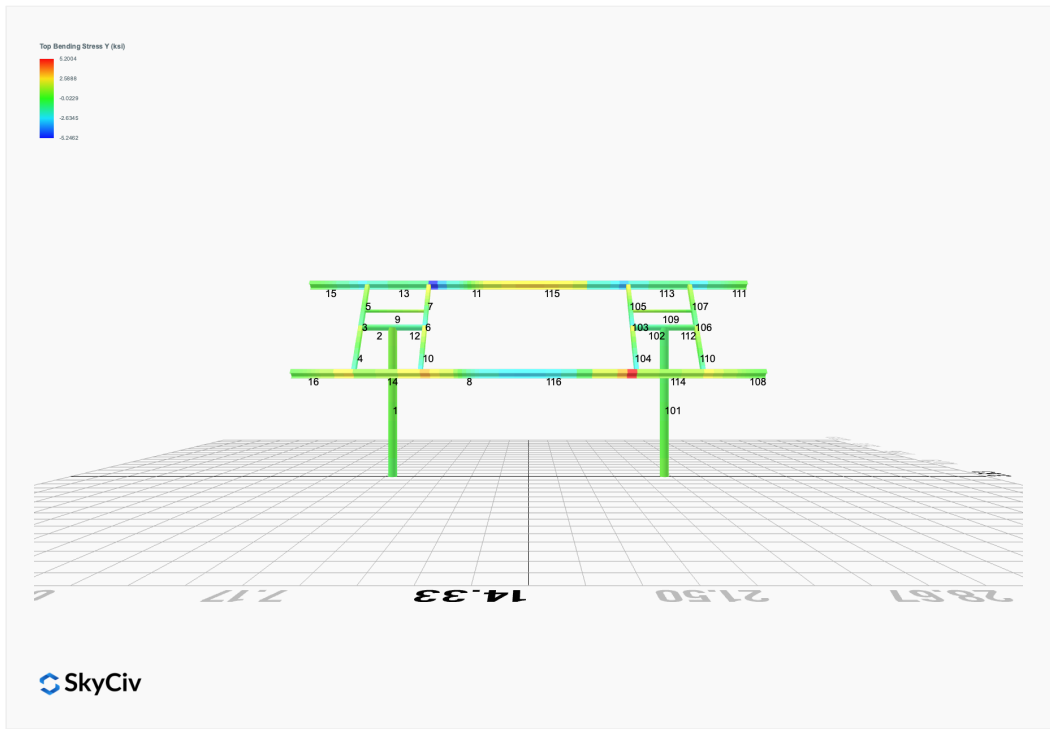

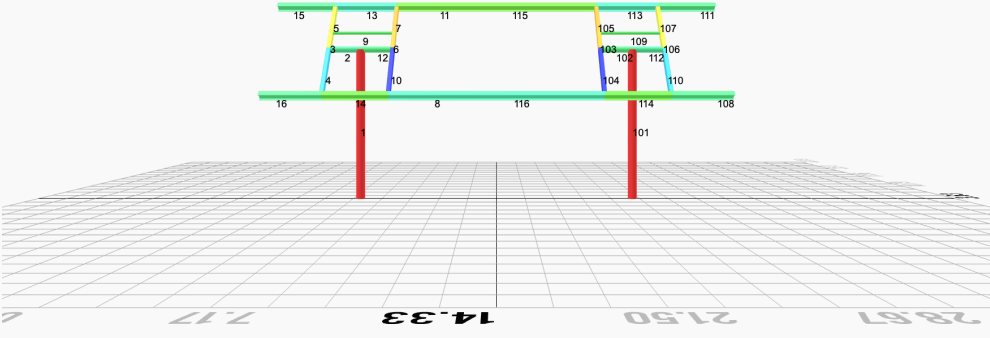

Reaction Forces for Foundation 1 (Node ID#1), (kip, kip-ft)

ASD Load Combination Results

Name	Fx	Fy	Fz	Mx	My	Mz
ULS: 1. D	0.0000	1.3823	0.0393	0.1115	-0.0379	0.0147
ULS: 2. D + L	0.0000	1.3823	0.0393	0.1115	-0.0379	0.0147
ULS: 3. D + (S or Lr or R)	0.0000	2.7466	0.0902	0.2560	-0.0873	0.0181
ULS: 3. D + (S or Lr or R)	0.0000	1.3823	0.0393	0.1115	-0.0379	0.0147
ULS: 4. D + 0.75L + 0.75(S or Lr or R)	0.0000	2.4055	0.0775	0.2198	-0.0750	0.0173
ULS: 4. D + 0.75L + 0.75(S or Lr or R)	0.0000	1.3823	0.0393	0.1115	-0.0379	0.0147
ULS: 5b. D + 0.7E	0.0000	1.3823	0.0393	0.1115	-0.0379	0.0147
ULS: 6b. D + 0.75L + 0.75(0.7)E + 0.75S	0.0000	2.4055	0.0775	0.2198	-0.0750	0.0173
ULS: 8. 0.6D + 0.7E	0.0000	0.8294	0.0236	0.0669	-0.0228	0.0088
ULS: 5a. D + 0.6W_Wind downforce Case A only	-1.5923	2.7184	0.1168	0.3206	-0.2890	15.0314
ULS: 5a. D + 0.6W_Wind downforce Case B only	0.0000	1.3823	0.0393	0.1115	-0.0379	0.0147
ULS: 5a. D + 0.6W_Wind uplift Case A only	1.5923	0.0462	-0.0381	-0.0969	0.2131	-14.6638
ULS: 5a. D + 0.6W_Wind uplift Case B only	0.0000	1.3823	0.0393	0.1115	-0.0379	0.0147
ULS: 6a. D + 0.75L + 0.75(0.6)W + 0.75(S or Lr or R)_Wind downforce Case A only	-1.1942	3.4076	0.1356	0.3767	-0.2633	11.2798
ULS: 6a. D + 0.75L + 0.75(0.6)W + 0.75(S or Lr or R)_Wind downforce Case B only	0.0000	2.4055	0.0775	0.2198	-0.0750	0.0173
ULS: 6a. D + 0.75L + 0.75(0.6)W + 0.75(S or Lr or R)_Wind uplift Case A only	1.1942	1.4035	0.0194	0.0636	0.1133	-10.9916
ULS: 6a. D + 0.75L + 0.75(0.6)W + 0.75(S or Lr or R)_Wind uplift Case B only	0.0000	2.4055	0.0775	0.2198	-0.0750	0.0173
ULS: 6a. D + 0.75L + 0.75(0.6)W + 0.75(S or Lr or R)_Wind downforce Case A only	-1.1942	2.3843	0.0974	0.2683	-0.2262	11.2772
ULS: 6a. D + 0.75L + 0.75(0.6)W + 0.75(S or Lr or R)_Wind downforce Case B only	0.0000	1.3823	0.0393	0.1115	-0.0379	0.0147
ULS: 6a. D + 0.75L + 0.75(0.6)W + 0.75(S or Lr or R)_Wind uplift Case A only	1.1942	0.3802	-0.0188	-0.0448	0.1504	-10.9942
ULS: 6a. D + 0.75L + 0.75(0.6)W + 0.75(S or Lr or R)_Wind uplift Case B only	0.0000	1.3823	0.0393	0.1115	-0.0379	0.0147
ULS: 7. 0.6D + 0.6W_Wind downforce Case A only	-1.5923	2.1654	0.1011	0.2760	-0.2738	15.0255
ULS: 7. 0.6D + 0.6W_Wind downforce Case B only	0.0000	0.8294	0.0236	0.0669	-0.0228	0.0088
ULS: 7. 0.6D + 0.6W_Wind uplift Case A only	1.5923	-0.5067	-0.0538	-0.1415	0.2283	-14.6697
ULS: 7. 0.6D + 0.6W_Wind uplift Case B only	0.0000	0.8294	0.0236	0.0669	-0.0228	0.0088

Worst Case Reactions LRFD

These calculations are taken directly from the FEA via SkyCiv and are used in the Concrete Checks of the Foundation Module.

Note: Worst case values are assumed as downforce wind load cases.

Result	Value (kip, kip-ft)
Axial	4.9550
Shear X	-2.6538
Shear Z	0.2017
Moment X	0.5548
Moment Y (Twist)	0.4877
Moment Z	25.3815

Worst Case Reactions ASD

These results are taken from the worst case values in the above table and are used in the Soil Checks in the Foundation Module.

Note: Worst case values are assumed as downforce wind load cases.

Result	Value (kip, kip-ft)
Axial	3.4076
Shear X	-1.5923
Shear Z	0.1356
Moment X	0.3767
Moment Y (Twist)	0.2890
Moment Z	15.0314

Reaction Forces for Foundation 2 (Node ID#101), (kip, kip-ft)

ASD Load Combination Results

Name	Fx	Fy	Fz	Mx	My	Mz
ULS: 1. D	-0.0000	1.3823	-0.0393	-0.1115	0.0379	0.0147
ULS: 2. D + L	-0.0000	1.3823	-0.0393	-0.1115	0.0379	0.0147
ULS: 3. D + (S or Lr or R)	-0.0000	2.7466	-0.0902	-0.2560	0.0873	0.0182
ULS: 3. D + (S or Lr or R)	-0.0000	1.3823	-0.0393	-0.1115	0.0379	0.0147
ULS: 4. D + 0.75L + 0.75(S or Lr or R)	-0.0000	2.4055	-0.0775	-0.2198	0.0750	0.0173

Name	Fx	Fy	Fz	Mx	My	Mz
ULS: 4. D + 0.75L + 0.75(S or Lr or R)	-0.0000	1.3823	-0.0393	-0.1115	0.0379	0.0147
ULS: 5b. D + 0.7E	-0.0000	1.3823	-0.0393	-0.1115	0.0379	0.0147
ULS: 6b. D + 0.75L + 0.75(0.7)E + 0.75S	-0.0000	2.4055	-0.0775	-0.2198	0.0750	0.0173
ULS: 8. 0.6D + 0.7E	-0.0000	0.8294	-0.0236	-0.0669	0.0228	0.0088
ULS: 5a. D + 0.6W_Wind downforce Case A only	-1.5923	2.7184	-0.1168	-0.3206	0.2890	15.0314
ULS: 5a. D + 0.6W_Wind downforce Case B only	-0.0000	1.3823	-0.0393	-0.1115	0.0379	0.0147
ULS: 5a. D + 0.6W_Wind uplift Case A only	1.5923	0.0462	0.0381	0.0969	-0.2131	-14.6638
ULS: 5a. D + 0.6W_Wind uplift Case B only	-0.0000	1.3823	-0.0393	-0.1115	0.0379	0.0147
ULS: 6a. D + 0.75L + 0.75(0.6)W + 0.75(S or Lr or R)_Wind downforce Case A only	-1.1942	3.4076	-0.1356	-0.3767	0.2633	11.2798
ULS: 6a. D + 0.75L + 0.75(0.6)W + 0.75(S or Lr or R)_Wind downforce Case B only	-0.0000	2.4055	-0.0775	-0.2198	0.0750	0.0173
ULS: 6a. D + 0.75L + 0.75(0.6)W + 0.75(S or Lr or R)_Wind uplift Case A only	1.1942	1.4035	-0.0194	-0.0636	-0.1133	-10.9916
ULS: 6a. D + 0.75L + 0.75(0.6)W + 0.75(S or Lr or R)_Wind uplift Case B only	-0.0000	2.4055	-0.0775	-0.2198	0.0750	0.0173
ULS: 6a. D + 0.75L + 0.75(0.6)W + 0.75(S or Lr or R)_Wind downforce Case A only	-1.1942	2.3843	-0.0974	-0.2683	0.2262	11.2772
ULS: 6a. D + 0.75L + 0.75(0.6)W + 0.75(S or Lr or R)_Wind downforce Case B only	-0.0000	1.3823	-0.0393	-0.1115	0.0379	0.0147
ULS: 6a. D + 0.75L + 0.75(0.6)W + 0.75(S or Lr or R)_Wind uplift Case A only	1.1942	0.3802	0.0188	0.0448	-0.1503	-10.9941
ULS: 6a. D + 0.75L + 0.75(0.6)W + 0.75(S or Lr or R)_Wind uplift Case B only	-0.0000	1.3823	-0.0393	-0.1115	0.0379	0.0147
ULS: 7. 0.6D + 0.6W_Wind downforce Case A only	-1.5923	2.1654	-0.1011	-0.2760	0.2738	15.0255
ULS: 7. 0.6D + 0.6W_Wind downforce Case B only	-0.0000	0.8294	-0.0236	-0.0669	0.0228	0.0088
ULS: 7. 0.6D + 0.6W_Wind uplift Case A only	1.5923	-0.5067	0.0538	0.1415	-0.2283	-14.6697
ULS: 7. 0.6D + 0.6W_Wind uplift Case B only	-0.0000	0.8294	-0.0236	-0.0669	0.0228	0.0088

Worst Case Reactions LRFD

These calculations are taken directly from the FEA via SkyCiv and are used in the Concrete Checks of the Foundation Module.
Note: Worst case values are assumed as downforce wind load cases.

Result	Value (kip, kip-ft)
Axial	4.9550
Shear X	-2.6538
Shear Z	-0.2017
Moment X	-0.5549
Moment Y (Twist)	0.4875
Moment Z	25.3821

Worst Case Reactions ASD

These results are taken from the worst case values in the above table and are used in the Soil Checks in the Foundation Module.
Note: Worst case values are assumed as downforce wind load cases.

Result	Value (kip, kip-ft)
Axial	3.4076
Shear X	-1.5923
Shear Z	-0.1356
Moment X	-0.3767
Moment Y (Twist)	0.2890
Moment Z	15.0314

Project Details

Design Code: AISC 360-16 LRFD
 Provision: LRFD
 Country: United States
 User Name: sales@mtsolar.us
 Unit System: imperial



Design Input Information

Design Factors			
Φ_t	Φ_c	Φ_b	Φ_v
0.9	0.9	0.9	0.9

Design Materials			
ID	E (ksi)	F_y (ksi)	F_u (ksi)
1	29000	50	65

Section Dimensions

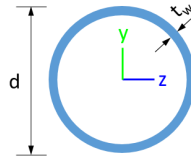

ID	Name	d (in)	t_w (in)				
1	2in Pipe Sch 40	2.38	0.15				
4	4in Pipe Sch 40	4.50	0.24				
7	6in Pipe Sch 40	6.63	0.28				

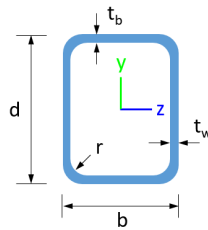

ID	Name	d (in)	b (in)	t_w (in)	t_b (in)	r (in)	
15	HSS5x3x1/8	5.00	3.00	0.12	0.12	0.12	

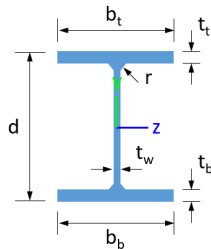

ID	Name	d (in)	t_w (in)	b_t (in)	b_b (in)	t_t (in)	t_b (in)	r (in)
18	W6x9	5.90	0.17	3.94	3.94	0.21	0.21	0.25

Section Properties

ID	Name	A (in ²)	J (in ⁴)	I_{yp} (in ⁴)	I_{zp} (in ⁴)	I_w (in ⁶)	S_{yp} (in ³)	S_{zp} (in ³)
----	------	----------------------	----------------------	-----------------------------	-----------------------------	--------------------------	-----------------------------	-----------------------------

1	2in Pipe Sch 40	1.07	1.33	0.67	0.67	0.00	0.76	0.76
4	4in Pipe Sch 40	3.17	14.47	7.23	7.23	0.00	4.31	4.31
7	6in Pipe Sch 40	5.58	56.28	28.14	28.14	0.00	11.28	11.28
15	HSS5x3x1/8	1.77	6.02	2.75	6.03	0.51	2.07	2.93
18	W6x9	2.68	0.04	2.20	16.40	17.70	1.72	6.23

Member Properties

Member ID	Section ID	K _z L (ft)	K _y L (ft)	L _b (ft)	C _b	LS T	LS C	L D
1	7	19.58	19.58	9.32	-	30	20	1
2	4	1.30	1.30	2.00	-	30	20	1
3	15	0.92	0.92	1.42	1.19,1.18,1.19,1.18,1.18,1.19,1.18,1.18,1.17,1.18,1.18,1.19,1.17,1.19,1.18,1.18,1.19,1.18,1.18,1.19,1.1	30	20	1
4	15	2.44	2.44	3.75	1.69,1.68,1.69,1.68,1.68,1.69,1.67,1.68,1.66,1.68,1.67,1.69,1.66,1.69,1.67,1.68,1.71,1.68,1.67,1.69,1.6	30	20	1
5	15	1.52	1.52	2.33	1.68,1.67,1.68,1.67,1.68,1.68,1.67,1.67,1.66,1.67,1.67,1.68,1.66,1.68,1.67,1.67,1.69,1.67,1.67,1.68,1.6	30	20	1
6	15	0.92	0.92	1.42	1.19,1.19,1.19,1.18,1.19,1.19,1.18,1.19,1.18,1.19,1.18,1.19,1.18,1.20,1.18,1.18,1.19,1.1	30	20	1
7	15	1.52	1.52	2.33	1.68,1.67,1.68,1.67,1.68,1.68,1.67,1.67,1.66,1.67,1.67,1.68,1.66,1.68,1.67,1.67,1.69,1.67,1.67,1.68,1.6	30	20	1
8	18	1.33	1.33	2.05	1.29,1.29,1.29,1.29,1.29,1.29,1.28,1.29,1.27,1.29,1.28,1.29,1.27,1.29,1.28,1.29,1.36,1.29,1.28,1.29,1.2	30	20	1
9	1	2.60	2.60	4.00	-	30	20	1
10	15	2.44	2.44	3.75	1.69,1.68,1.69,1.67,1.68,1.69,1.67,1.68,1.66,1.68,1.67,1.69,1.66,1.69,1.67,1.67,1.70,1.67,1.67,1.69,1.6	30	20	1
11	18	1.33	1.33	2.05	1.29,1.29,1.29,1.29,1.29,1.29,1.28,1.29,1.27,1.29,1.28,1.29,1.28,1.29,1.29,1.29,1.37,1.29,1.28,1.29,1.2	30	20	1
12	4	1.30	1.30	2.00	-	30	20	1
13	18	4.88	4.00	7.50	1.23,1.23,1.23,1.23,1.23,1.23,1.25,1.23,1.28,1.23,1.25,1.23,1.27,1.23,1.24,1.23,1.14,1.23,1.25,1.23,1.2	30	20	1
14	18	4.88	4.00	7.50	1.22,1.22,1.22,1.22,1.22,1.22,1.24,1.22,1.27,1.22,1.25,1.22,1.26,1.22,1.24,1.22,1.13,1.22,1.24,1.22,1.2	30	20	1
15	18	4.20	4.20	2.00	2.33,2.33,2.33,2.33,2.33,2.33,2.33,2.33,2.33,2.33,2.33,2.33,2.33,2.33,2.33,2.33,2.33,2.33,2.33,2.3	30	20	1
16	18	4.20	4.20	2.00	2.33,2.33,2.33,2.33,2.33,2.33,2.33,2.33,2.33,2.33,2.33,2.33,2.33,2.33,2.33,2.33,2.33,2.33,2.3	30	20	1
101	7	19.58	19.58	9.32	-	30	20	1
102	4	1.30	1.30	2.00	-	30	20	1
103	15	0.92	0.92	1.42	1.19,1.19,1.19,1.18,1.19,1.19,1.18,1.19,1.18,1.19,1.18,1.19,1.18,1.19,1.18,1.20,1.18,1.18,1.19,1.1	30	20	1
104	15	2.44	2.44	3.75	1.69,1.68,1.69,1.67,1.68,1.69,1.67,1.68,1.66,1.68,1.67,1.69,1.66,1.69,1.67,1.67,1.70,1.67,1.67,1.69,1.6	30	20	1
105	15	1.52	1.52	2.33	1.68,1.67,1.68,1.67,1.68,1.68,1.67,1.67,1.66,1.67,1.67,1.68,1.66,1.68,1.67,1.67,1.69,1.67,1.67,1.68,1.6	30	20	1
106	15	0.92	0.92	1.42	1.19,1.18,1.19,1.18,1.18,1.19,1.18,1.18,1.17,1.18,1.18,1.19,1.17,1.19,1.18,1.18,1.19,1.18,1.19,1.1	30	20	1
107	15	1.52	1.52	2.33	1.68,1.67,1.68,1.67,1.68,1.68,1.67,1.67,1.66,1.67,1.67,1.68,1.66,1.68,1.67,1.67,1.69,1.67,1.67,1.68,1.6	30	20	1
108	18	4.20	4.20	2.00	2.33,2.33,2.33,2.33,2.33,2.33,2.33,2.33,2.33,2.33,2.33,2.33,2.33,2.33,2.33,2.33,2.33,2.33,2.3	30	20	1
109	1	2.60	2.60	4.00	-	30	20	1
110	15	2.44	2.44	3.75	1.69,1.68,1.69,1.68,1.68,1.69,1.67,1.68,1.66,1.68,1.67,1.69,1.66,1.69,1.67,1.68,1.71,1.68,1.67,1.69,1.6	30	20	1
111	18	4.20	4.20	2.00	2.33,2.33,2.33,2.33,2.33,2.33,2.33,2.33,2.33,2.33,2.33,2.33,2.33,2.33,2.33,2.33,2.33,2.33,2.3	30	20	1
112	4	1.30	1.30	2.00	-	30	20	1

113	18	4.88	4.00	7.50	1.23,1.23,1.23,1.23,1.23,1.23,1.25,1.23,1.28,1.23,1.25,1.23,1.27,1.23,1.24,1.23,1.14,1.23,1.25,1.23,1.29,1.23,1.25,1.23,1.27,1.23	300	200	1
114	18	4.88	4.00	7.50	1.22,1.22,1.22,1.22,1.22,1.22,1.24,1.22,1.27,1.22,1.25,1.22,1.26,1.22,1.24,1.22,1.13,1.22,1.24,1.22,1.28,1.22,1.25,1.22,1.26,1.22	300	200	1
115	18	4.84	4.84	7.45	1.09,1.09,1.09,1.09,1.09,1.09,1.09,1.09,1.08,1.09,1.09,1.09,1.08,1.09,1.09,1.09,1.10,1.09,1.09,1.09,1.08,1.09,1.09,1.09,1.08,1.09	300	200	1
116	18	4.84	4.84	7.45	1.09,1.09,1.09,1.09,1.09,1.09,1.08,1.09,1.08,1.09,1.08,1.09,1.08,1.09,1.09,1.09,1.10,1.09,1.09,1.09,1.08,1.09,1.09,1.09,1.08,1.09	300	200	1

Member Design Capacity

Member ID	$\Phi_t P_n$ (kip)	$\Phi_c P_n$ (kip)	$\Phi_b M_{zn}$ (k-ft)	$\Phi_b M_{yn}$ (k-ft)	$\Phi_v V_{yn}$ (kip)	$\Phi_v V_{zn}$ (kip)
1	251.16	112.80	42.30	42.30	75.35	75.35
2	142.83	141.72	16.17	16.17	42.85	42.85
3	79.65	74.89	10.99	6.26	29.14	16.61
4	79.65	72.84	10.99	6.26	29.14	16.61
5	79.65	74.30	10.99	6.26	29.14	16.61
6	79.65	74.89	10.99	6.26	29.14	16.61
7	79.65	74.30	10.99	6.26	29.14	16.61
8	120.60	115.40	23.36	6.45	30.09	45.74
9	48.35	43.11	2.85	2.85	14.51	14.51
10	79.65	72.84	10.99	6.26	29.14	16.61
11	120.60	115.40	23.36	6.45	30.09	45.74
12	142.83	141.72	16.17	16.17	42.85	42.85
13	120.60	84.03	20.09	6.45	30.09	45.74
14	120.60	84.03	19.91	6.45	30.09	45.74
15	120.60	96.18	23.36	6.45	30.09	45.74
16	120.60	96.18	23.36	6.45	30.09	45.74
101	251.16	112.80	42.30	42.30	75.35	75.35
102	142.83	141.72	16.17	16.17	42.85	42.85
103	79.65	74.89	10.99	6.26	29.14	16.61
104	79.65	72.84	10.99	6.26	29.14	16.61
105	79.65	74.30	10.99	6.26	29.14	16.61
106	79.65	74.89	10.99	6.26	29.14	16.61
107	79.65	74.30	10.99	6.26	29.14	16.61
108	120.60	96.18	23.36	6.45	30.09	45.74
109	48.35	43.11	2.85	2.85	14.51	14.51
110	79.65	72.84	10.99	6.26	29.14	16.61
111	120.60	96.18	23.36	6.45	30.09	45.74
112	142.83	141.72	16.17	16.17	42.85	42.85
113	120.60	84.03	20.11	6.45	30.09	45.74
114	120.60	84.03	19.88	6.45	30.09	45.74
115	120.60	84.26	19.13	6.45	30.09	45.74
116	120.60	84.26	19.12	6.45	30.09	45.74

Design Ratio

Member ID	P	M_z	M_y	V_y	V_z	(P, M_z , M_y)	Worst LC	KL/r	δ	Status
1	0.044	0.600	0.031	0.035	0.003	0.633	#13	0.523	Not Required	Pass
2	0.001	0.185	0.146	0.046	0.030	0.323	#13	0.052	Not Required	Pass
3	0.008	0.370	0.052	0.037	0.010	0.398	#13	0.044	Not Required	Pass
4	0.007	0.368	0.080	0.037	0.016	0.427	#13	0.078	Not Required	Pass

5	0.007	0.230	0.061	0.037	0.011	0.233	#13	0.073	Not Required	Pass
6	0.011	0.449	0.116	0.046	0.026	0.523	#13	0.044	Not Required	Pass
7	0.011	0.278	0.144	0.045	0.028	0.299	#13	0.073	Not Required	Pass
8	0.002	0.087	0.061	0.026	0.010	0.134	#21	0.088	Not Required	Pass
9	0.001	0.027	0.052	0.002	0.002	0.072	#13	0.198	Not Required	Pass
10	0.011	0.447	0.137	0.045	0.025	0.489	#13	0.078	Not Required	Pass
11	0.002	0.087	0.061	0.026	0.010	0.133	#21	0.088	Not Required	Pass
12	0.001	0.263	0.177	0.064	0.034	0.435	#13	0.052	Not Required	Pass
13	0.003	0.066	0.192	0.036	0.013	0.228	#21	0.265	Not Required	Pass
14	0.003	0.068	0.190	0.036	0.013	0.224	#21	0.177	Not Required	Pass
15	0.000	0.014	0.029	0.011	0.004	0.041	#21	Not Required	Not Required	Pass
16	0.000	0.014	0.029	0.011	0.004	0.041	#21	Not Required	Not Required	Pass
101	0.044	0.600	0.031	0.035	0.003	0.633	#13	0.523	Not Required	Pass
102	0.001	0.263	0.177	0.064	0.034	0.435	#13	0.052	Not Required	Pass
103	0.011	0.449	0.116	0.046	0.026	0.523	#13	0.044	Not Required	Pass
104	0.011	0.447	0.137	0.045	0.025	0.489	#13	0.078	Not Required	Pass
105	0.011	0.278	0.144	0.045	0.028	0.299	#13	0.073	Not Required	Pass
106	0.008	0.370	0.052	0.037	0.010	0.398	#13	0.044	Not Required	Pass
107	0.007	0.230	0.061	0.037	0.011	0.233	#13	0.073	Not Required	Pass
108	0.000	0.014	0.029	0.011	0.004	0.041	#21	Not Required	Not Required	Pass
109	0.001	0.027	0.052	0.002	0.002	0.072	#13	0.198	Not Required	Pass
110	0.007	0.368	0.080	0.037	0.016	0.427	#13	0.078	Not Required	Pass
111	0.000	0.014	0.029	0.011	0.004	0.041	#21	Not Required	Not Required	Pass
112	0.001	0.185	0.146	0.046	0.030	0.323	#13	0.052	Not Required	Pass
113	0.003	0.066	0.192	0.036	0.013	0.228	#21	0.177	Not Required	Pass
114	0.003	0.068	0.190	0.036	0.013	0.224	#21	0.265	Not Required	Pass
115	0.003	0.137	0.114	0.026	0.010	0.227	#21	0.321	Not Required	Pass
116	0.002	0.138	0.114	0.026	0.010	0.228	#21	0.321	Not Required	Pass

Definitions

Φ_t	Safety factor for tensile
Φ_c	Safety factor for compression
Φ_b	Safety factor for flexure
Φ_v	Safety factor for shear
E	Modulus of elasticity
F_y	Specified minimum yield stress
F_u	Specified minimum tensile strength
A	Cross-sectional area
J	Torsional constant
I_{yp}	Moment of inertia about the Y axes
I_{zp}	Moment of inertia about the Z axes
I_w	Warping constant
S_{yp}	Plastic section modulus about the Y axis
S_{zp}	Plastic section modulus about the Z axis
KL	Effective length
C_b	Buckling modification factor (from all load combinations)
L_b	Length between braced points
LST	Limited slenderness for tension
LSC	Limited slenderness for compression
LD	Limited deflection
P_n	Nominal axial strength (tension/compression)
M_n	Nominal flexural strength (about Z/Y axis)
V_n	Nominal shear strength (along Z/Y axis)
P	Design ratio in case of axial force
M_z	Design ratio in case of bending about Z axis
M_y	Design ratio in case of bending about Y axis
V_y	Design ratio in case of shear along Y axis
V_z	Design ratio in case of shear along Z axis

(P,M _z ,M _y)	Design ratio in case of axial force and bending action
KL/r	Design ratio in case of section slenderness
δ	Design ratio in case of member deflection
OK	Capacity is provided
NG	Capacity is not provided

REFERENCES	CALCULATIONS	RESULTS
------------	--------------	---------

SkyCiv Foundation Design

Pile Foundation

Design Information :

Design code : IBC 2021 (International Building Code)
Unit System : Imperial

Pile Input

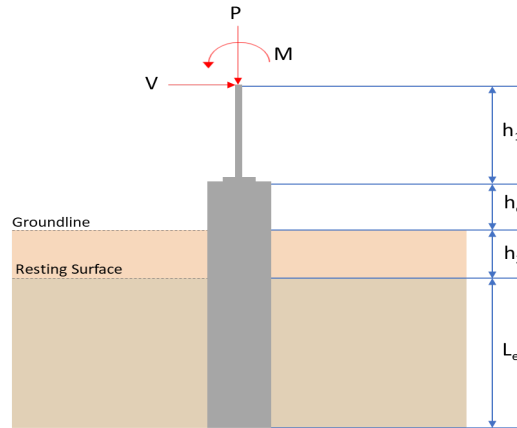

Geometry

Pile shape: rectangular

$b = 48$ in - Pile width

$D = 48$ in - Pile depth

$L = 5.25$ ft - Total pile length

$h_1 = 0$ ft - Lateral load height from the top of the pile,

$h_2 = 0$ ft - Depth to resisting surface

$h_e = 0$ ft - Length of pile above the ground

Tabulation of Soil Parameters

Layer	Label	Allowable Bearing Pressure (q_a) (psf)	Allowable Lateral Pressure (R) (psf/ft)
1	Sand, silty sand, clayey sand, silty gravel & clayey gravel	2000.000	150.000

Tabulation of Loads

Load Component	ASD	LRFD
P (kip)	3.408	4.955
V_x (kip)	-1.592	-2.654
V_z (kip)	0.136	0.202
M_x (kipft)	0.377	0.555
M_z (kipft)	15.031	25.382

Material Properties

$f'_{ck} = 2.5$ ksi - Concrete strength.

Required depth to resist lateral loads (ASD)

H - Point of application of the lateral load

$$H = h_1 + h_2 + h_e$$

$$H = (0 \text{ ft}) + (0 \text{ ft}) + (0 \text{ ft})$$

$$H = 0 \text{ ft}$$

Considering x-direction:

H_o - Lateral force per length of pile,

$$H_o = \frac{V_x}{1.57 D}$$

$$H_o = \frac{(-1.592 \text{ kip})}{1.57 \times (48 \text{ in})}$$

$$H_o = -0.2535 \text{ kip/ft}$$

M_o - Moment per length of pile,

$$M_o = \frac{M_z + (V_x H)}{1.57 D}$$

$$M_o = \frac{(15.031 \text{ kipft}) + ((-1.592 \text{ kip}) \times (0 \text{ ft}))}{1.57 \times (48 \text{ in})}$$

$$M_o = 2.3935 \text{ kipft/ft}$$

Required depth of embedment in earth:

$$L_e^3 - \left(14.14 \times \frac{H_o \times L_x}{R} \right) - \left(18.85 \times \frac{M_o}{R} \right) = 0$$

Solving the cubic equation:

$L_{e,x} = 4.892 \text{ ft}$ - Required depth in x-direction,

Considering z-direction:

H_o - Lateral force per length of pile,

$$H_o = \frac{V_z}{1.57 b}$$

$$H_o = \frac{(0.136 \text{ kip})}{1.57 \times (48 \text{ in})}$$

$$H_o = 0.021656 \text{ kip/ft}$$

M_o - Moment per length of pile,

$$M_o = \frac{M_x + (V_z H)}{1.57 b}$$

$$M_o = \frac{(0.377 \text{ kipft}) + ((0.136 \text{ kip}) \times (0 \text{ ft}))}{1.57 \times (48 \text{ in})}$$

$$M_o = 0.060032 \text{ kipft/ft}$$

Required depth of embedment in earth:

$$L_e^3 - \left(14.14 \times \frac{H_o \times L_z}{R} \right) - \left(18.85 \times \frac{M_o}{R} \right) = 0$$

Solving the cubic equation:

$L_{e,z} = 1.9422 \text{ ft}$ - Required depth in z-direction,

Minimum embedded depth required:

$L_{e,req}$ - Depth of pile required,

$$L_{e,req} = \text{MAX}[L_{e,x}, L_{e,z}]$$

$$L_{e,req} = \text{MAX}[(4.892 \text{ ft}), (1.9422 \text{ ft})]$$

$$L_{e,req} = 4.892 \text{ ft}$$

L_e - Actual embedded length of pile,

$$L_e = L - h_e - h_2$$

$$L_e = (5.25 \text{ ft}) - (0 \text{ ft}) - (0 \text{ ft})$$

$$L_e = 5.25 \text{ ft}$$

Ratio - Embedded depth

$$\text{Ratio} = \frac{L_{e,req}}{L_e}$$

$$\text{Ratio} = \frac{(4.892 \text{ ft})}{(5.25 \text{ ft})}$$

$$\text{Ratio} = 0.93181$$

Status: **PASS**
Ratio: **0.930**

End-bearing Capacity (ASD)

A - Pile cross-section area

$$A = b D$$

$$A = (48 \text{ in}) \times (48 \text{ in})$$

$$A = 16 \text{ ft}^2$$

q - End-bearing pressure

$$q = \frac{P_v}{A}$$

$$q = \frac{(3.408 \text{ kip})}{(16 \text{ ft}^2)}$$

$$q = 0.213 \text{ kip/ft}^2$$

Check bearing capacity ratio:

Ratio - Capacity

$$\text{Ratio} = \frac{q}{q_a}$$

$$\text{Ratio} = \frac{(0.213 \text{ kip/ft}^2)}{(2000 \text{ psf})}$$

$$\text{Ratio} = 0.1065$$

Status: **PASS**
Ratio: **0.110**

Czerniak

Lateral Soil Pressure (ASD):

L/D - Length to least lateral dimension ratio,

$$L/D = \frac{L}{D}$$

$$L/D = \frac{(5.25 \text{ ft})}{(48 \text{ in})}$$

$$L/D = 1.3125$$

Since $L/D \leq 10$,

Pile is short.

Considering x-direction:

$H_o = -0.2535 \text{ kip/ft}$ - Lateral force per length of pile,

$M_o = 2.3935 \text{ kipft/ft}$ - Overturning moment per length of pile,

a - Distance from resting surface to pivot point,

$$a = \frac{(4 M_o L_e) + (3 H_o L_e^2)}{(6 M_o) + (4 H_o L_e)}$$

$$a = \frac{(4 \times (2.3935 \text{ kipft/ft}) \times (5.25 \text{ ft})) + (3 \times (-0.2535 \text{ kip/ft}) \times (5.25 \text{ ft})^2)}{(6 \times (2.3935 \text{ kipft/ft})) + (4 \times (-0.2535 \text{ kip/ft}) \times (5.25 \text{ ft}))}$$

$$a = 3.6183 \text{ ft}$$

p - Earth pressure against the pile at distance $a/2$ from resting surface,

$$p = \frac{0.75 [(4 M_o) + (3 H_o L_e)]^2}{L_e^2 [(3 M_o) + (2 H_o L_e)]}$$

$$p = \frac{0.75 \times [(4 \times (2.3935 \text{ kipft/ft})) + (3 \times (-0.2535 \text{ kip/ft}) \times (5.25 \text{ ft}))]^2}{(5.25 \text{ ft})^2 \times [(3 \times (2.3935 \text{ kipft/ft})) + (2 \times (-0.2535 \text{ kip/ft}) \times (5.25 \text{ ft}))]}$$

$$p = 0.18758 \text{ kip/ft}^2$$

s - Earth pressure against the pile at distance L_e ,

$$s = \frac{6 [(2 M_o) + (H_o L_e)]}{L_e^2}$$

$$s = \frac{6 \times [(2 \times (2.3935 \text{ kipft/ft})) + ((-0.2535 \text{ kip/ft}) \times (5.25 \text{ ft}))]}{(5.25 \text{ ft})^2}$$

$$s = 0.75234 \text{ kip/ft}^2$$

Check lateral soil pressure capacity:

p_a - Allowable lateral soil pressure at depth $a/2$,

$$p_a = R \frac{a}{2}$$

$$p_a = (150 \text{ psf/ft}) \times \frac{(3.6183 \text{ ft})}{2}$$

$$p_a = 0.27137 \text{ kip/ft}^2$$

Ratio - Lateral soil capacity

$$Ratio = \frac{p}{p_a}$$

$$Ratio = \frac{(0.18758 \text{ kip/ft}^2)}{(0.27137 \text{ kip/ft}^2)}$$

$$Ratio = 0.69123$$

p_s - Allowable lateral soil pressure at depth L_e ,

$$p_s = R L_e$$

$$p_s = (150 \text{ psf/ft}) \times (5.25 \text{ ft})$$

$$p_s = 0.7875 \text{ kip/ft}^2$$

Ratio - Lateral soil capacity

$$Ratio = \frac{s}{p_s}$$

$$Ratio = \frac{(0.75234 \text{ kip/ft}^2)}{(0.7875 \text{ kip/ft}^2)}$$

$$Ratio = 0.95535$$

Status: **PASS**
Ratio: **0.690**

Status: **PASS**
Ratio: **0.960**

Considering z-direction:

$H_o = 0.021656 \text{ kip/ft}$ - Lateral force per length of pile,

$M_o = 0.060032 \text{ kipft/ft}$ - Overturning moment per length of pile,

a - Distance from resting surface to pivot point,

$$a = \frac{(4 M_o L_e) + (3 H_o L_e^2)}{(6 M_o) + (4 H_o L_e)}$$

$$a = \frac{(4 \times (0.060032 \text{ kipft/ft}) \times (5.25 \text{ ft})) + (3 \times (0.021656 \text{ kip/ft}) \times (5.25 \text{ ft})^2)}{(6 \times (0.060032 \text{ kipft/ft})) + (4 \times (0.021656 \text{ kip/ft}) \times (5.25 \text{ ft}))}$$

$$a = 3.7441 \text{ ft}$$

p - Earth pressure against the pile at distance $a/2$ from resting surface,

$$p = \frac{0.75 [(4 M_o) + (3 H_o L_e)]^2}{L_e^2 [(3 M_o) + (2 H_o L_e)]}$$

$$p = \frac{0.75 \times [(4 \times (0.060032 \text{ kipft/ft})) + (3 \times (0.021656 \text{ kip/ft}) \times (5.25 \text{ ft}))]^2}{(5.25 \text{ ft})^2 \times [(3 \times (0.060032 \text{ kipft/ft})) + (2 \times (0.021656 \text{ kip/ft}) \times (5.25 \text{ ft}))]}$$

$$p = 0.022558 \text{ kip/ft}^2$$

s - Earth pressure against the pile at distance L_e ,

$$s = \frac{6 [(2 M_o) + (H_o L_e)]}{L_e^2}$$

$$s = \frac{6 \times [(2 \times (0.060032 \text{ kipft/ft})) + ((0.021656 \text{ kip/ft}) \times (5.25 \text{ ft}))]}{(5.25 \text{ ft})^2}$$

$$s = 0.050886 \text{ kip/ft}^2$$

Check lateral soil pressure capacity:

p_a - Allowable lateral soil pressure at depth $a/2$,

$$p_a = R \frac{a}{2}$$

$$p_a = (150 \text{ psf/ft}) \times \frac{(3.7441 \text{ ft})}{2}$$

$$p_a = 0.28081 \text{ kip/ft}^2$$

Ratio - Lateral soil capacity

$$Ratio = \frac{p}{p_a}$$

$$Ratio = \frac{(0.022558 \text{ kip/ft}^2)}{(0.28081 \text{ kip/ft}^2)}$$

$$Ratio = 0.080331$$

p_s - Allowable lateral soil pressure at depth L_e ,

$$p_s = R L_e$$

$$p_s = (150 \text{ psf/ft}) \times (5.25 \text{ ft})$$

$$p_s = 0.7875 \text{ kip/ft}^2$$

Ratio - Lateral soil capacity

$$Ratio = \frac{s}{p_s}$$

$$Ratio = \frac{(0.050886 \text{ kip/ft}^2)}{(0.7875 \text{ kip/ft}^2)}$$

$$Ratio = 0.064617$$

Status: **PASS**
Ratio: **0.080**

Status: **PASS**
Ratio: **0.060**

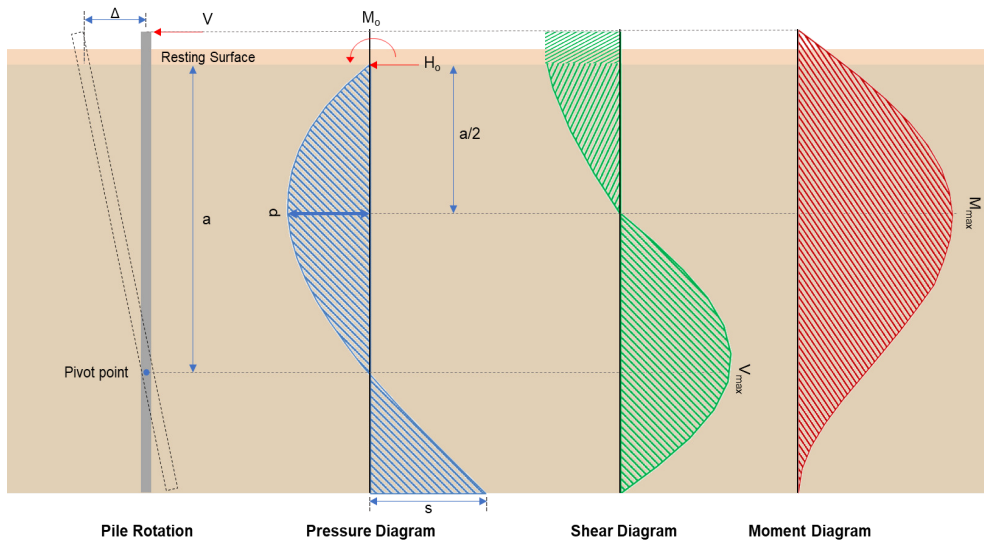

Shear force and Bending moment (x-direction, LRFD)

H_o - Lateral force per length of pile,

$$H_o = \frac{V_x}{1.57 D}$$

$$H_o = \frac{(-2.654 \text{ kip})}{1.57 \times (48 \text{ in})}$$

$$H_o = -0.42261 \text{ kip/ft}$$

M_o - Moment per length of pile,

$$M_o = \frac{M_z + (V_x H)}{1.57 D}$$

$$M_o = \frac{(25.382 \text{ kipft}) + ((-2.654 \text{ kip}) \times (0 \text{ ft}))}{1.57 \times (48 \text{ in})}$$

$$M_o = 4.0417 \text{ kipft/ft}$$

E - Distance from lateral load to resisting surface,

$$E = \frac{M_o}{H_o}$$

$$E = \frac{(4.0417 \text{ kipft/ft})}{(-0.42261 \text{ kip/ft})}$$

$$E = 9.5637 \text{ ft}$$

a - Distance from resting surface to pivot point,

$$a = \frac{(4 M_o L_e) + (3 H_o L_e^2)}{(6 M_o) + (4 H_o L_e)}$$

$$a = \frac{(4 \times (4.0417 \text{ kipft/ft}) \times (5.25 \text{ ft})) + (3 \times (-0.42261 \text{ kip/ft}) \times (5.25 \text{ ft})^2)}{(6 \times (4.0417 \text{ kipft/ft})) + (4 \times (-0.42261 \text{ kip/ft}) \times (5.25 \text{ ft}))}$$

$$a = \frac{(-0.42261 \text{ kip/ft}) \times (48 \text{ in})}{(6 \times (4.0417 \text{ kipft/ft})) + (4 \times (-0.42261 \text{ kip/ft}) \times (5.25 \text{ ft}))}$$

$$a = 3.6172 \text{ ft}$$

V_{max} - Max shear force located at depth a,

$$V_{max} = (H_o D) \left[1 - \left[3 \left(\frac{4E}{L_e} + 3 \right) \left(\frac{a}{L_e} \right)^2 \right] + \left[4 \left(\frac{3E}{L_e} + 2 \right) \left(\frac{a}{L_e} \right)^3 \right] \right]$$

$$V_{max} = ((-0.42261 \text{ kip/ft}) \times (48 \text{ in})) \times \left[1 - \left[3 \times \left(\frac{4 \times (9.5637 \text{ ft})}{(5.25 \text{ ft})} + 3 \right) \times \left(\frac{(3.6172 \text{ ft})}{(5.25 \text{ ft})} \right)^2 \right] + \left[4 \times \left(\frac{3 \times (9.5637 \text{ ft})}{(5.25 \text{ ft})} + 2 \right) \times \left(\frac{(3.6172 \text{ ft})}{(5.25 \text{ ft})} \right)^3 \right] \right]$$

$$V_{max} = 6.5643 \text{ kip}$$

M_{max} - Max bending moment located at depth a/2,

$$M_{max} = (H_o D L_e) \left[\left(\frac{E}{L_e} + \frac{a}{2 L_e} \right) - \left[\left(\frac{4E}{L_e} + 3 \right) \left(\frac{a}{2 L_e} \right)^3 \right] + \left[\left(\frac{3E}{L_e} + 2 \right) \left(\frac{a}{2 L_e} \right)^4 \right] \right]$$

$$M_{max} = ((-0.42261 \text{ kip/ft}) \times (48 \text{ in}) \times (5.25 \text{ ft})) \times \left[\left(\frac{(9.5637 \text{ ft})}{(5.25 \text{ ft})} + \frac{(3.6172 \text{ ft})}{2 \times (5.25 \text{ ft})} \right) - \left[\left(\frac{4 \times (9.5637 \text{ ft})}{(5.25 \text{ ft})} + 3 \right) \times \left(\frac{(3.6172 \text{ ft})}{2 \times (5.25 \text{ ft})} \right)^3 \right] + \left[\left(\frac{3 \times (9.5637 \text{ ft})}{(5.25 \text{ ft})} + 2 \right) \times \left(\frac{(3.6172 \text{ ft})}{2 \times (5.25 \text{ ft})} \right)^4 \right] \right]$$

$$M_{max} = 16.425 \text{ kipft}$$

Shear force and Bending moment (z-direction, LRFD)

H_o - Lateral force per length of pile,

$$H_o = \frac{V_z}{1.57 b}$$

$$H_o = \frac{(0.202 \text{ kip})}{1.57 \times (48 \text{ in})}$$

$$H_o = 0.032166 \text{ kip/ft}$$

M_o - Moment per length of pile,

$$M_o = \frac{M_x + (V_z H)}{1.57 b}$$

$$M_o = \frac{(0.555 \text{ kipft}) + ((0.202 \text{ kip}) \times (0 \text{ ft}))}{1.57 \times (48 \text{ in})}$$

$$M_o = 0.088376 \text{ kipft/ft}$$

E - Distance from lateral load to resisting surface,

$$E = \frac{M_o}{H_o}$$

$$E = \frac{(0.088376 \text{ kipft/ft})}{(0.032166 \text{ kip/ft})}$$

$$E = 2.7475 \text{ ft}$$

a - Distance from resting surface to pivot point,

$$a = \frac{(4 M_o L_e) + (3 H_o L_e^2)}{(6 M_o) + (4 H_o L_e)}$$

$$a = \frac{(4 \times (0.088376 \text{ kipft/ft}) \times (5.25 \text{ ft})) + (3 \times (0.032166 \text{ kip/ft}) \times (5.25 \text{ ft})^2)}{(6 \times (0.088376 \text{ kipft/ft})) + (4 \times (0.032166 \text{ kip/ft}) \times (5.25 \text{ ft}))}$$

$$a = 3.7451 \text{ ft}$$

V_{max} - Max shear force located at depth a,

$$V_{max} = (H_o b) \left[1 - \left[3 \left(\frac{4E}{L_e} + 3 \right) \left(\frac{a}{L_e} \right)^2 \right] + \left[4 \left(\frac{3E}{L_e} + 2 \right) \left(\frac{a}{L_e} \right)^3 \right] \right]$$

$$V_{max} = ((0.032166 \text{ kip/ft}) \times (48 \text{ in})) \times \left[1 - \left[3 \times \left(\frac{4 \times (2.7475 \text{ ft})}{(5.25 \text{ ft})} + 3 \right) \times \left(\frac{(3.7451 \text{ ft})}{(5.25 \text{ ft})} \right)^2 \right] \right. \\ \left. + \left[4 \times \left(\frac{3 \times (2.7475 \text{ ft})}{(5.25 \text{ ft})} + 2 \right) \times \left(\frac{(3.7451 \text{ ft})}{(5.25 \text{ ft})} \right)^3 \right] \right]$$

$$V_{max} = 0.20481 \text{ kip}$$

M_{max} - Max bending moment located at depth $a/2$,

$$M_{max} = (H_o \cdot b \cdot L_e) \left[\left(\frac{E}{L_e} + \frac{a}{2 L_e} \right) \right. \\ \left. - \left[\left(\frac{4E}{L_e} + 3 \right) \left(\frac{a}{2 L_e} \right)^3 \right] + \left[\left(\frac{3E}{L_e} + 2 \right) \left(\frac{a}{2 L_e} \right)^4 \right] \right]$$

$$M_{max} = ((0.032166 \text{ kip/ft}) \times (48 \text{ in}) \times (5.25 \text{ ft})) \times \left[\left(\frac{(2.7475 \text{ ft})}{(5.25 \text{ ft})} + \frac{(3.7451 \text{ ft})}{2 \times (5.25 \text{ ft})} \right) \right. \\ \left. - \left[\left(\frac{4 \times (2.7475 \text{ ft})}{(5.25 \text{ ft})} + 3 \right) \times \left(\frac{(3.7451 \text{ ft})}{2 \times (5.25 \text{ ft})} \right)^3 \right] + \left[\left(\frac{3 \times (2.7475 \text{ ft})}{(5.25 \text{ ft})} + 2 \right) \times \left(\frac{(3.7451 \text{ ft})}{2 \times (5.25 \text{ ft})} \right)^4 \right] \right]$$

$$M_{max} = 0.47735 \text{ kipft}$$

Minimum Reinforcement Check (LRFD)

Parameters:

$f'_{ck} = 2.5 \text{ ksi}$ - Concrete strength,

$f_{yk} = 60 \text{ ksi}$ - Longitudinal reinforcement strength,

$\phi = 0.65$ - Reduction factor for axial strength,

$\alpha = 0.8$ - Alpha factor for axial strength,

$A_g = 2304 \text{ in}^2$ - Gross area of concrete,

Longitudinal reinforcement:

Required reinforcement due to axial load, $A_{st,required}$

$A_{st,required}$

$$A_{st,required} = \text{Min} \left[\frac{\frac{P}{\phi \alpha} - (0.85 f'_{ck} A_g)}{f_{yk} - (0.85 f'_{ck})}, (0.08 A_g) \right]$$

$$A_{st,required} = \text{Min} \left[\frac{\frac{(4.955 \text{ kip})}{(0.65) \times (0.8)} - (0.85 \times (2.5 \text{ ksi}) \times (2304 \text{ in}^2))}{(60 \text{ ksi}) - (0.85 \times (2.5 \text{ ksi}))}, (0.08 \times (2304 \text{ in}^2)) \right]$$

$$A_{st,required} = -84.431 \text{ in}^2$$

A_{min} - Governing minimum reinforcement area,

$$A_{min} = \text{Max} [A_{st,required}, (0.0018 A_g)]$$

$$A_{min} = \text{Max} [(-84.431 \text{ in}^2), (0.0018 \times (2304 \text{ in}^2))]$$

$$A_{min} = 4.1472 \text{ in}^2$$

n_{rebar} - Required number of reinforcement,

$$n_{rebar} = \frac{A_{min}}{A_{rebar}}$$

$$n_{rebar} = \frac{(4.1472 \text{ in}^2)}{(0.3068 \text{ in}^2)}$$

$$n_{rebar} = 14$$

A_{st} - Actual total reinforcement area,

$$A_{st} = n_{rebar} \frac{\pi d_{bar}^2}{4}$$

$$A_{st} = (14) \times \frac{\pi \times (0.625 \text{ in})^2}{4}$$

$$A_{st} = 4.2951 \text{ in}^2$$

Ratio - Capacity

$$\text{Ratio} = \frac{A_{min}}{A_{st}}$$

$$\text{Ratio} = \frac{(4.1472 \text{ in}^2)}{(4.2951 \text{ in}^2)}$$

Table 22.4.2.1

22.4.2.2, 10.6.1.1

<p>25.2.3</p> <p>25.7.2.2</p> <p>25.7.2.1</p>	<p style="text-align: center;">$Ratio = 0.96556$</p> <p>$s_{rebar} = Max[1.5, (1.5 d_{bar})]$</p> <p>$s_{rebar} = Max[1.5, (1.5 \times (0.625 \text{ in}))]$</p> <p>$s_{rebar} = 1.5 \text{ in}$</p> <p>Ties:</p> <p>Since longitudinal reinforcement is \leq No. 10ø: Use #3(0.375 in)</p> <p>$s_{ties} = Min[(16 d_{bar}), (48 d_{ties}), Min(D, b)]$</p> <p>$s_{ties} = Min[(16 \times (0.625 \text{ in})), (48 \times (0.375 \text{ in})), Min((48 \text{ in}), (48 \text{ in}))]$</p> <p>$s_{ties} = 10 \text{ in}$</p> <p>Summary:</p> <p style="text-align: center;">Main reinforcement: 14 - #5 (0.625 in) Ties: #3(0.375 in) - 10 in</p>	<p>Status: PASS Ratio: 0.970</p>
<p>22.4.2.2</p>	<p>Axial Compression Strength (ACI 318-19, LRFD)</p> <p>ϕP_N - Allowable axial compressive strength</p> <p style="text-align: center;">$\phi P_N = \phi 0.80 [(0.85 f'_{ck} [A_g - A_{st}]) + (f_y k A_{st})]$</p> <p style="text-align: center;">$\phi P_N = (0.65) \times 0.80 \times [(0.85 \times (2.5 \text{ ksi}) \times [(2304 \text{ in}^2) - (4.2951 \text{ in}^2)]) + ((60 \text{ ksi}) \times (4.2951 \text{ in}^2))]$</p> <p style="text-align: center;">$\phi P_N = 2675.2 \text{ kip}$</p> <p>Ratio - Capacity</p> <p style="text-align: center;">$Ratio = \frac{P}{\phi P_N}$</p> <p style="text-align: center;">$Ratio = \frac{(4.955 \text{ kip})}{(2675.2 \text{ kip})}$</p> <p style="text-align: center;">$Ratio = 0.0018522$</p>	<p>Status: PASS Ratio: 0.000</p>
<p>22.5.2.2</p> <p>22.5.5.1.3</p> <p>22.5.5.1.1</p>	<p>Shear Strength (ACI 318-19, LRFD)</p> <p>Parameters:</p> <p>$b_w = 48 \text{ in}$ - Effective width, d - Effective depth</p> <p style="text-align: center;">$d = 0.80 D$</p> <p style="text-align: center;">$d = 0.80 \times (48 \text{ in})$</p> <p style="text-align: center;">$d = 38.4 \text{ in}$</p> <p>λ_s - size effect modification factor</p> <p style="text-align: center;">$\lambda_s = MIN \left[\sqrt{\frac{2}{1 + \frac{d}{10}}}, 1 \right]$</p> <p style="text-align: center;">$\lambda_s = MIN \left[\sqrt{\frac{2}{1 + \frac{(38.4 \text{ in})}{10}}}, 1 \right]$</p> <p style="text-align: center;">$\lambda_s = 0.64282$</p> <p>The following variables were converted to be consistent with empirical formula $f'_{ck} = 2.5 \text{ ksi} \rightarrow 2500 \text{ psi}$,</p> <p>$V_{c,max}$ - Max shear strength of concrete</p> <p style="text-align: center;">$V_{c,max} = 5 \lambda_s \sqrt{f'_{ck}} b_w d$</p> <p style="text-align: center;">$V_{c,max} = 5 \times (0.64282) \times \sqrt{(2500 \text{ psi})} \times (48 \text{ in}) \times (38.4 \text{ in})$</p>	

$$V_{c,max} = 296.21 \text{ kip}$$

22.5.5.1.1(a) The following variables were converted to be consistent with empirical formula $f'_{ck} = 2.5 \text{ ksi} \rightarrow 2500 \text{ psi}$, $P = 4.955 \text{ kip} \rightarrow 4955 \text{ lbf}$,
 $V_{c,a}$ - Shear strength of concrete (a)

$$V_{c,a} = \left[2 \lambda_s \sqrt{f'_{ck} + \frac{P}{6 A_g}} \right] b_w d$$

$$V_{c,a} = \left[2 \times (0.64282) \times \sqrt{(2500 \text{ psi}) + \frac{(4955 \text{ lbf})}{6 \times (2304 \text{ in}^2)}} \right] \times (48 \text{ in}) \times (38.4 \text{ in})$$

$$V_{c,a} = 119.15 \text{ kip}$$

22.5.5.1.2 The following variables were converted to be consistent with empirical formula $f'_{ck} = 2.5 \text{ ksi} \rightarrow 2500 \text{ psi}$,
 $V_{c,b}$ - Shear strength of concrete (b)

$$V_{c,b} = \left[2 \lambda_s \sqrt{f'_{ck} + (0.05 f'_{ck})} \right] b_w d$$

$$V_{c,b} = \left[2 \times (0.64282) \times \sqrt{(2500 \text{ psi}) + (0.05 \times (2500 \text{ psi}))} \right] \times (48 \text{ in}) \times (38.4 \text{ in})$$

$$V_{c,b} = 348.89 \text{ kip}$$

V_c - Governing shear strength of concrete

$$V_c = \text{Min}[V_{c,max}, V_{c,a}, V_{c,b}]$$

$$V_c = \text{Min}[(296.21 \text{ kip}), (119.15 \text{ kip}), (348.89 \text{ kip})]$$

$$V_c = 119.15 \text{ kip}$$

22.5.5.1.2 The following variables were converted to be consistent with empirical formula $f'_{ck} = 2.5 \text{ ksi} \rightarrow 2500 \text{ psi}$,
 $V_{s,a}$ - Shear strength of steel (a)

$$V_{s,a} = 8 \sqrt{f'_{ck}} b_w d$$

$$V_{s,a} = 8 \times \sqrt{(2500 \text{ psi})} \times (48 \text{ in}) \times (38.4 \text{ in})$$

$$V_{s,a} = 737.28 \text{ kip}$$

A_v - Ties rebar area,

$$A_v = \frac{\pi d_{ties}^2}{4}$$

$$A_v = \frac{\pi \times (0.375 \text{ in})^2}{4}$$

$$A_v = 0.11045 \text{ in}^2$$

22.5.8.5.3 $V_{s,b}$ - Shear strength of steel (b)

$$V_{s,b} = \frac{2 A_v f_{yw} d}{s_{ties}}$$

$$V_{s,b} = \frac{2 \times (0.11045 \text{ in}^2) \times (60 \text{ ksi}) \times (38.4 \text{ in})}{(10 \text{ in})}$$

$$V_{s,b} = 50.894 \text{ kip}$$

V_s - Governing shear strength of steel

$$V_s = \text{MIN}[V_{s,a}, V_{s,b}]$$

$$V_s = \text{MIN}[(737.28 \text{ kip}), (50.894 \text{ kip})]$$

$$V_s = 50.894 \text{ kip}$$

22.5.1.1 ϕV_n - Allowable shear strength

$$\phi V_n = \phi (V_c + V_s)$$

$$\phi V_n = (0.65) \times ((119.15 \text{ kip}) + (50.894 \text{ kip}))$$

$$\phi V_n = 110.53 \text{ kip}$$

Considering x-direction:

$V_{max} = 6.5643 \text{ kip}$ - Maximum shear force in the x-direction,

$Ratio$ - Capacity

$$Ratio = \frac{V_{max}}{\phi V_n}$$

$$Ratio = \frac{(6.5643 \text{ kip})}{(110.53 \text{ kip})}$$

$$Ratio = 0.059391$$

Status: **PASS**
Ratio: **0.060**

Considering z-direction:

$V_{max} = 0.20481 \text{ kip}$ - Maximum shear force in the z-direction,
 $Ratio$ - Capacity

$$Ratio = \frac{V_{max}}{\phi V_n}$$

$$Ratio = \frac{(0.20481 \text{ kip})}{(110.53 \text{ kip})}$$

$$Ratio = 0.0018531$$

Status: **PASS**
Ratio: **0.000**

Flexural Strength (ACI 318-19, LRFD)

S_m - Section modulus

$$S_m = \frac{b D^2}{6}$$

$$S_m = \frac{(48 \text{ in}) \times (48 \text{ in})^2}{6}$$

$$S_m = 18432 \text{ in}^3$$

$\lambda = 1$ - Concrete modification factor (Normal concrete),

Allowable flexural strength:

M_n shall be the lesser of:

$\phi M_{n,1}$

$$\phi M_{n,1} = \phi \times 5 \times \lambda \times \sqrt{f'_c} \times S_m$$

$$\phi M_{n,1} = 0.65 \times 5 \times 1 \times \sqrt{(2.5 \text{ ksi})} \times 18432.001 \text{ in}^3$$

$$\phi M_{n,1} = 249.600 \text{ kipft}$$

14.5.2.1b

$\phi M_{n,2}$

$$\phi M_{n,2} = \phi \times 0.85 \times f'_c \times S_m$$

$$\phi M_{n,2} = (0.65) \times 0.85 \times (2.5 \text{ ksi}) \times (18432 \text{ in}^3)$$

$$\phi M_{n,2} = 2121.6 \text{ kipft}$$

Therefore,

ϕM_n - Allowable flexural strength,

$$\phi M_n = \text{MIN}[\phi M_{n,1}, \phi M_{n,2}]$$

$$\phi M_n = \text{MIN}[(249.6 \text{ kipft}), (2121.6 \text{ kipft})]$$

$$\phi M_n = 249.6 \text{ kipft}$$

Considering x-direction:

$M_{max} = 16.425 \text{ kipft}$ - Maximum moment in the x-direction,

$Ratio$ - Capacity

$$Ratio = \frac{M_{max}}{\phi M_n}$$

$$Ratio = \frac{(16.425 \text{ kipft})}{(249.6 \text{ kipft})}$$

$$Ratio = 0.065805$$

Status: **PASS**
Ratio: **0.070**

Considering z-direction:

$M_{max} = 0.47735 \text{ kipft}$ - Maximum moment in the z-direction,

$Ratio$ - Capacity

$$Ratio = \frac{M_{max}}{\phi M_n}$$

$$Ratio = \frac{(0.47735 \text{ kipft})}{(249.6 \text{ kipft})}$$

$$Ratio = 0.0019124$$

Status: **PASS**
Ratio: **0.000**

REFERENCES	CALCULATIONS	RESULTS
------------	--------------	---------

SkyCiv Foundation Design

Pile Foundation

Design Information :

Design code : IBC 2021 (International Building Code)
Unit System : Imperial

Pile Input

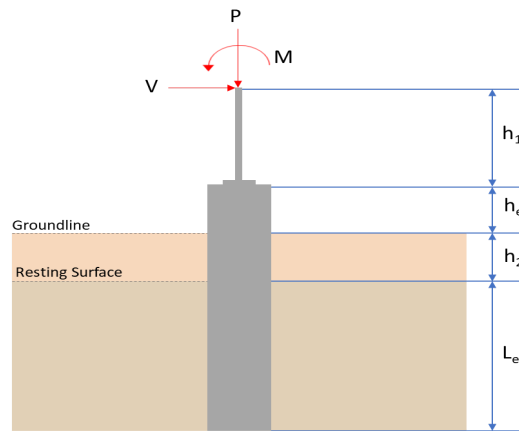

Geometry

Pile shape: rectangular

$b = 48$ in - Pile width

$D = 48$ in - Pile depth

$L = 5.25$ ft - Total pile length

$h_1 = 0$ ft - Lateral load height from the top of the pile,

$h_2 = 0$ ft - Depth to resisting surface

$h_e = 0$ ft - Length of pile above the ground

Tabulation of Soil Parameters

Layer	Label	Allowable Bearing Pressure (q_a) (psf)	Allowable Lateral Pressure (R) (psf/ft)
1	Sand, silty sand, clayey sand, silty gravel & clayey gravel	2000.000	150.000

Tabulation of Loads

Load Component	ASD	LRFD
P (kip)	3.408	4.955
V_x (kip)	-1.592	-2.654
V_z (kip)	-0.136	-0.202
M_x (kipft)	-0.377	-0.555
M_z (kipft)	15.031	25.382

Material Properties

$f'_{ck} = 2.5$ ksi - Concrete strength.

Required depth to resist lateral loads (ASD)

H - Point of application of the lateral load

$$H = h_1 + h_2 + h_e$$

$$H = (0 \text{ ft}) + (0 \text{ ft}) + (0 \text{ ft})$$

$$H = 0 \text{ ft}$$

Considering x-direction:

H_o - Lateral force per length of pile,

$$H_o = \frac{V_x}{1.57 D}$$

$$H_o = \frac{(-1.592 \text{ kip})}{1.57 \times (48 \text{ in})}$$

$$H_o = -0.2535 \text{ kip/ft}$$

M_o - Moment per length of pile,

$$M_o = \frac{M_z + (V_x H)}{1.57 D}$$

$$M_o = \frac{(15.031 \text{ kipft}) + ((-1.592 \text{ kip}) \times (0 \text{ ft}))}{1.57 \times (48 \text{ in})}$$

$$M_o = 2.3935 \text{ kipft/ft}$$

Required depth of embedment in earth:

$$L_x^3 - \left(14.14 \times \frac{H_o \times L_x}{R} \right) - \left(18.85 \times \frac{M_o}{R} \right) = 0$$

Solving the cubic equation:

$L_{e,x} = 4.892 \text{ ft}$ - Required depth in x-direction,

Considering z-direction:

H_o - Lateral force per length of pile,

$$H_o = \frac{V_z}{1.57 b}$$

$$H_o = \frac{(-0.136 \text{ kip})}{1.57 \times (48 \text{ in})}$$

$$H_o = -0.021656 \text{ kip/ft}$$

M_o - Moment per length of pile,

$$M_o = \frac{M_x + (V_z H)}{1.57 b}$$

$$M_o = \frac{(0.377 \text{ kipft}) + ((-0.136 \text{ kip}) \times (0 \text{ ft}))}{1.57 \times (48 \text{ in})}$$

$$M_o = 0.060032 \text{ kipft/ft}$$

Required depth of embedment in earth:

$$L_z^3 - \left(14.14 \times \frac{H_o \times L_z}{R} \right) - \left(18.85 \times \frac{M_o}{R} \right) = 0$$

Solving the cubic equation:

$L_{e,z} = 1.4327 \text{ ft}$ - Required depth in z-direction,

Minimum embedded depth required:

$L_{e,req}$ - Depth of pile required,

$$L_{e,req} = \text{MAX}[L_{e,x}, L_{e,z}]$$

$$L_{e,req} = \text{MAX}[(4.892 \text{ ft}), (1.4327 \text{ ft})]$$

$$L_{e,req} = 4.892 \text{ ft}$$

L_e - Actual embedded length of pile,

$$L_e = L - h_e - h_2$$

$$L_e = (5.25 \text{ ft}) - (0 \text{ ft}) - (0 \text{ ft})$$

$$L_e = 5.25 \text{ ft}$$

Ratio - Embedded depth

$$\text{Ratio} = \frac{L_{e,req}}{L_e}$$

$$\text{Ratio} = \frac{(4.892 \text{ ft})}{(5.25 \text{ ft})}$$

$$\text{Ratio} = 0.93181$$

Status: **PASS**
Ratio: **0.930**

End-bearing Capacity (ASD)

A - Pile cross-section area

$$A = b D$$

$$A = (48 \text{ in}) \times (48 \text{ in})$$

$$A = 16 \text{ ft}^2$$

q - End-bearing pressure

$$q = \frac{P_v}{A}$$

$$q = \frac{(3.408 \text{ kip})}{(16 \text{ ft}^2)}$$

$$q = 0.213 \text{ kip/ft}^2$$

Check bearing capacity ratio:

Ratio - Capacity

$$\text{Ratio} = \frac{q}{q_a}$$

$$\text{Ratio} = \frac{(0.213 \text{ kip/ft}^2)}{(2000 \text{ psf})}$$

$$\text{Ratio} = 0.1065$$

Status: **PASS**
Ratio: **0.110**

Czerniak

Lateral Soil Pressure (ASD):

L/D - Length to least lateral dimension ratio,

$$L/D = \frac{L}{D}$$

$$L/D = \frac{(5.25 \text{ ft})}{(48 \text{ in})}$$

$$L/D = 1.3125$$

Since $L/D \leq 10$,

Pile is short.

Considering x-direction:

$H_o = -0.2535 \text{ kip/ft}$ - Lateral force per length of pile,

$M_o = 2.3935 \text{ kipft/ft}$ - Overturning moment per length of pile,

a - Distance from resting surface to pivot point,

$$a = \frac{(4 M_o L_e) + (3 H_o L_e^2)}{(6 M_o) + (4 H_o L_e)}$$

$$a = \frac{(4 \times (2.3935 \text{ kipft/ft}) \times (5.25 \text{ ft})) + (3 \times (-0.2535 \text{ kip/ft}) \times (5.25 \text{ ft})^2)}{(6 \times (2.3935 \text{ kipft/ft})) + (4 \times (-0.2535 \text{ kip/ft}) \times (5.25 \text{ ft}))}$$

$$a = 3.6183 \text{ ft}$$

p - Earth pressure against the pile at distance $a/2$ from resting surface,

$$p = \frac{0.75 [(4 M_o) + (3 H_o L_e)]^2}{L_e^2 [(3 M_o) + (2 H_o L_e)]}$$

$$p = \frac{0.75 \times [(4 \times (2.3935 \text{ kipft/ft})) + (3 \times (-0.2535 \text{ kip/ft}) \times (5.25 \text{ ft}))]^2}{(5.25 \text{ ft})^2 \times [(3 \times (2.3935 \text{ kipft/ft})) + (2 \times (-0.2535 \text{ kip/ft}) \times (5.25 \text{ ft}))]}$$

$$p = 0.18758 \text{ kip/ft}^2$$

s - Earth pressure against the pile at distance L_e ,

$$s = \frac{6 [(2 M_o) + (H_o L_e)]}{L_e^2}$$

$$s = \frac{6 \times [(2 \times (2.3935 \text{ kipft/ft})) + ((-0.2535 \text{ kip/ft}) \times (5.25 \text{ ft}))]}{(5.25 \text{ ft})^2}$$

$$s = 0.75234 \text{ kip/ft}^2$$

Check lateral soil pressure capacity:

p_a - Allowable lateral soil pressure at depth $a/2$,

$$p_a = R \frac{a}{2}$$

$$p_a = (150 \text{ psf/ft}) \times \frac{(3.6183 \text{ ft})}{2}$$

$$p_a = 0.27137 \text{ kip/ft}^2$$

Ratio - Lateral soil capacity

$$Ratio = \frac{p}{p_a}$$

$$Ratio = \frac{(0.18758 \text{ kip/ft}^2)}{(0.27137 \text{ kip/ft}^2)}$$

$$Ratio = 0.69123$$

p_s - Allowable lateral soil pressure at depth L_e ,

$$p_s = R L_e$$

$$p_s = (150 \text{ psf/ft}) \times (5.25 \text{ ft})$$

$$p_s = 0.7875 \text{ kip/ft}^2$$

Ratio - Lateral soil capacity

$$Ratio = \frac{s}{p_s}$$

$$Ratio = \frac{(0.75234 \text{ kip/ft}^2)}{(0.7875 \text{ kip/ft}^2)}$$

$$Ratio = 0.95535$$

Status: **PASS**
Ratio: **0.690**

Status: **PASS**
Ratio: **0.960**

Considering z-direction:

$H_o = -0.021656 \text{ kip/ft}$ - Lateral force per length of pile,

$M_o = 0.060032 \text{ kipft/ft}$ - Overturning moment per length of pile,

a - Distance from resting surface to pivot point,

$$a = \frac{(4 M_o L_e) + (3 H_o L_e^2)}{(6 M_o) + (4 H_o L_e)}$$

$$a = \frac{(4 \times (0.060032 \text{ kipft/ft}) \times (5.25 \text{ ft})) + (3 \times (-0.021656 \text{ kip/ft}) \times (5.25 \text{ ft})^2)}{(6 \times (0.060032 \text{ kipft/ft})) + (4 \times (-0.021656 \text{ kip/ft}) \times (5.25 \text{ ft}))}$$

$$a = 3.7441 \text{ ft}$$

p - Earth pressure against the pile at distance $a/2$ from resting surface,

$$p = \frac{0.75 [(4 M_o) + (3 H_o L_e)]^2}{L_e^2 [(3 M_o) + (2 H_o L_e)]}$$

$$p = \frac{0.75 \times [(4 \times (0.060032 \text{ kipft/ft})) + (3 \times (-0.021656 \text{ kip/ft}) \times (5.25 \text{ ft}))]^2}{(5.25 \text{ ft})^2 \times [(3 \times (0.060032 \text{ kipft/ft})) + (2 \times (-0.021656 \text{ kip/ft}) \times (5.25 \text{ ft}))]}$$

$$p = -0.0058642 \text{ kip/ft}^2$$

s - Earth pressure against the pile at distance L_e ,

$$s = \frac{6 [(2 M_o) + (H_o L_e)]}{L_e^2}$$

$$s = \frac{6 \times [(2 \times (0.060032 \text{ kipft/ft})) + ((-0.021656 \text{ kip/ft}) \times (5.25 \text{ ft}))]}{(5.25 \text{ ft})^2}$$

$$s = 0.0013865 \text{ kip/ft}^2$$

Check lateral soil pressure capacity:

p_a - Allowable lateral soil pressure at depth $a/2$,

$$p_a = R \frac{a}{2}$$

$$p_a = (150 \text{ psf/ft}) \times \frac{(3.7441 \text{ ft})}{2}$$

$$p_a = 0.28081 \text{ kip/ft}^2$$

Ratio - Lateral soil capacity

$$Ratio = \frac{p}{p_a}$$

$$Ratio = \frac{(-0.0058642 \text{ kip/ft}^2)}{(0.28081 \text{ kip/ft}^2)}$$

$$Ratio = -0.020883$$

Status: **PASS**
Ratio: **-0.020**

p_s - Allowable lateral soil pressure at depth L_e ,

$$p_s = R L_e$$

$$p_s = (150 \text{ psf/ft}) \times (5.25 \text{ ft})$$

$$p_s = 0.7875 \text{ kip/ft}^2$$

Ratio - Lateral soil capacity

$$Ratio = \frac{s}{p_s}$$

$$Ratio = \frac{(0.0013865 \text{ kip/ft}^2)}{(0.7875 \text{ kip/ft}^2)}$$

$$Ratio = 0.0017607$$

Status: **PASS**
Ratio: **0.000**

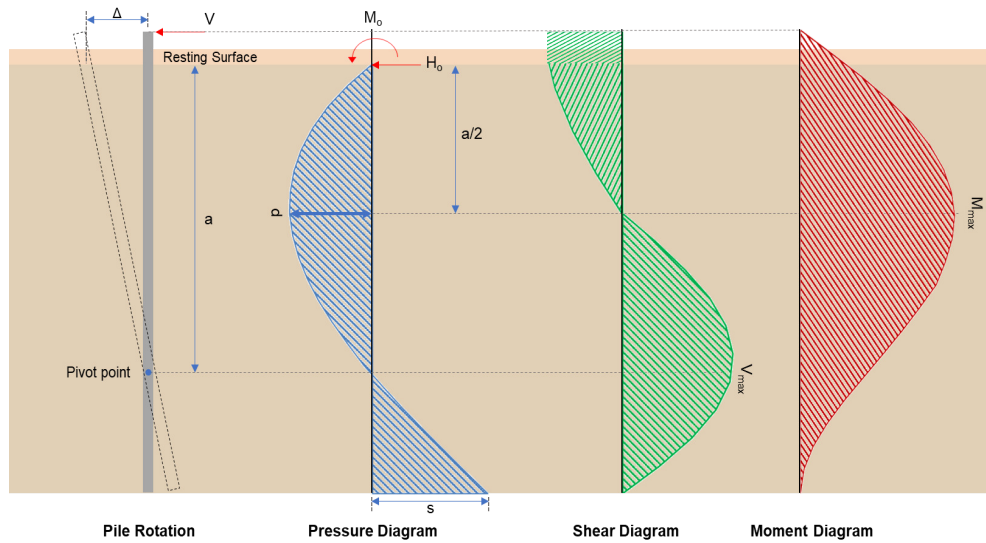

Shear force and Bending moment (x-direction, LRFD)

H_o - Lateral force per length of pile,

$$H_o = \frac{V_x}{1.57 D}$$

$$H_o = \frac{(-2.654 \text{ kip})}{1.57 \times (48 \text{ in})}$$

$$H_o = -0.42261 \text{ kip/ft}$$

M_o - Moment per length of pile,

$$M_o = \frac{M_z + (V_x H)}{1.57 D}$$

$$M_o = \frac{(25.382 \text{ kipft}) + ((-2.654 \text{ kip}) \times (0 \text{ ft}))}{1.57 \times (48 \text{ in})}$$

$$M_o = 4.0417 \text{ kipft/ft}$$

E - Distance from lateral load to resisting surface,

$$E = \frac{M_o}{H_o}$$

$$E = \frac{(4.0417 \text{ kipft/ft})}{(-0.42261 \text{ kip/ft})}$$

$$E = 9.5637 \text{ ft}$$

a - Distance from resting surface to pivot point,

$$a = \frac{(4 M_o L_e) + (3 H_o L_e^2)}{(6 M_o) + (4 H_o L_e)}$$

$$a = \frac{(4 \times (4.0417 \text{ kipft/ft}) \times (5.25 \text{ ft})) + (3 \times (-0.42261 \text{ kip/ft}) \times (5.25 \text{ ft})^2)}{(6 \times (4.0417 \text{ kipft/ft})) + (4 \times (-0.42261 \text{ kip/ft}) \times (5.25 \text{ ft}))}$$

$$a = \frac{(-0.42261 \text{ kip/ft}) \times (48 \text{ in})}{(6 \times (4.0417 \text{ kipft/ft})) + (4 \times (-0.42261 \text{ kip/ft}) \times (5.25 \text{ ft}))}$$

$$a = 3.6172 \text{ ft}$$

V_{max} - Max shear force located at depth a,

$$V_{max} = (H_o D) \left[1 - \left[3 \left(\frac{4E}{L_e} + 3 \right) \left(\frac{a}{L_e} \right)^2 \right] + \left[4 \left(\frac{3E}{L_e} + 2 \right) \left(\frac{a}{L_e} \right)^3 \right] \right]$$

$$V_{max} = ((-0.42261 \text{ kip/ft}) \times (48 \text{ in})) \times \left[1 - \left[3 \times \left(\frac{4 \times (9.5637 \text{ ft})}{(5.25 \text{ ft})} + 3 \right) \times \left(\frac{(3.6172 \text{ ft})}{(5.25 \text{ ft})} \right)^2 \right] + \left[4 \times \left(\frac{3 \times (9.5637 \text{ ft})}{(5.25 \text{ ft})} + 2 \right) \times \left(\frac{(3.6172 \text{ ft})}{(5.25 \text{ ft})} \right)^3 \right] \right]$$

$$V_{max} = 6.5643 \text{ kip}$$

M_{max} - Max bending moment located at depth a/2,

$$M_{max} = (H_o D L_e) \left[\left(\frac{E}{L_e} + \frac{a}{2 L_e} \right) - \left[\left(\frac{4E}{L_e} + 3 \right) \left(\frac{a}{2 L_e} \right)^3 \right] + \left[\left(\frac{3E}{L_e} + 2 \right) \left(\frac{a}{2 L_e} \right)^4 \right] \right]$$

$$M_{max} = ((-0.42261 \text{ kip/ft}) \times (48 \text{ in}) \times (5.25 \text{ ft})) \times \left[\left(\frac{(9.5637 \text{ ft})}{(5.25 \text{ ft})} + \frac{(3.6172 \text{ ft})}{2 \times (5.25 \text{ ft})} \right) - \left[\left(\frac{4 \times (9.5637 \text{ ft})}{(5.25 \text{ ft})} + 3 \right) \times \left(\frac{(3.6172 \text{ ft})}{2 \times (5.25 \text{ ft})} \right)^3 \right] + \left[\left(\frac{3 \times (9.5637 \text{ ft})}{(5.25 \text{ ft})} + 2 \right) \times \left(\frac{(3.6172 \text{ ft})}{2 \times (5.25 \text{ ft})} \right)^4 \right] \right]$$

$$M_{max} = 16.425 \text{ kipft}$$

Shear force and Bending moment (z-direction, LRFD)

H_o - Lateral force per length of pile,

$$H_o = \frac{V_z}{1.57 b}$$

$$H_o = \frac{(-0.202 \text{ kip})}{1.57 \times (48 \text{ in})}$$

$$H_o = -0.032166 \text{ kip/ft}$$

M_o - Moment per length of pile,

$$M_o = \frac{M_x + (V_z H)}{1.57 b}$$

$$M_o = \frac{(0.555 \text{ kipft}) + ((-0.202 \text{ kip}) \times (0 \text{ ft}))}{1.57 \times (48 \text{ in})}$$

$$M_o = 0.088376 \text{ kipft/ft}$$

E - Distance from lateral load to resisting surface,

$$E = \frac{M_o}{H_o}$$

$$E = \frac{(0.088376 \text{ kipft/ft})}{(-0.032166 \text{ kip/ft})}$$

$$E = 2.7475 \text{ ft}$$

a - Distance from resting surface to pivot point,

$$a = \frac{(4 M_o L_e) + (3 H_o L_e^2)}{(6 M_o) + (4 H_o L_e)}$$

$$a = \frac{(4 \times (0.088376 \text{ kipft/ft}) \times (5.25 \text{ ft})) + (3 \times (-0.032166 \text{ kip/ft}) \times (5.25 \text{ ft})^2)}{(6 \times (0.088376 \text{ kipft/ft})) + (4 \times (-0.032166 \text{ kip/ft}) \times (5.25 \text{ ft}))}$$

$$a = 3.7451 \text{ ft}$$

V_{max} - Max shear force located at depth a,

$$V_{max} = (H_o b) \left[1 - \left[3 \left(\frac{4E}{L_e} + 3 \right) \left(\frac{a}{L_e} \right)^2 \right] + \left[4 \left(\frac{3E}{L_e} + 2 \right) \left(\frac{a}{L_e} \right)^3 \right] \right]$$

$$V_{max} = ((-0.032166 \text{ kip/ft}) \times (48 \text{ in})) \times \left[1 - \left[3 \times \left(\frac{4 \times (2.7475 \text{ ft})}{(5.25 \text{ ft})} + 3 \right) \times \left(\frac{(3.7451 \text{ ft})}{(5.25 \text{ ft})} \right)^2 \right] \right. \\ \left. + \left[4 \times \left(\frac{3 \times (2.7475 \text{ ft})}{(5.25 \text{ ft})} + 2 \right) \times \left(\frac{(3.7451 \text{ ft})}{(5.25 \text{ ft})} \right)^3 \right] \right]$$

$$V_{max} = 0.20481 \text{ kip}$$

M_{max} - Max bending moment located at depth $a/2$,

$$M_{max} = (H_o \cdot b \cdot L_e) \left[\left(\frac{E}{L_e} + \frac{a}{2 L_e} \right) \right. \\ \left. - \left[\left(\frac{4E}{L_e} + 3 \right) \left(\frac{a}{2 L_e} \right)^3 \right] + \left[\left(\frac{3E}{L_e} + 2 \right) \left(\frac{a}{2 L_e} \right)^4 \right] \right]$$

$$M_{max} = ((-0.032166 \text{ kip/ft}) \times (48 \text{ in}) \times (5.25 \text{ ft})) \times \left[\left(\frac{(2.7475 \text{ ft})}{(5.25 \text{ ft})} + \frac{(3.7451 \text{ ft})}{2 \times (5.25 \text{ ft})} \right) \right. \\ \left. - \left[\left(\frac{4 \times (2.7475 \text{ ft})}{(5.25 \text{ ft})} + 3 \right) \times \left(\frac{(3.7451 \text{ ft})}{2 \times (5.25 \text{ ft})} \right)^3 \right] + \left[\left(\frac{3 \times (2.7475 \text{ ft})}{(5.25 \text{ ft})} + 2 \right) \times \left(\frac{(3.7451 \text{ ft})}{2 \times (5.25 \text{ ft})} \right)^4 \right] \right]$$

$$M_{max} = 0.47735 \text{ kipft}$$

Minimum Reinforcement Check (LRFD)

Parameters:

$f'_{ck} = 2.5 \text{ ksi}$ - Concrete strength,

$f_{yk} = 60 \text{ ksi}$ - Longitudinal reinforcement strength,

$\phi = 0.65$ - Reduction factor for axial strength,

$\alpha = 0.8$ - Alpha factor for axial strength,

$A_g = 2304 \text{ in}^2$ - Gross area of concrete,

Longitudinal reinforcement:

Required reinforcement due to axial load, $A_{st,required}$

$A_{st,required}$

$$A_{st,required} = \text{Min} \left[\frac{\frac{P}{\phi \alpha} - (0.85 f'_{ck} A_g)}{f_{yk} - (0.85 f'_{ck})}, (0.08 A_g) \right]$$

$$A_{st,required} = \text{Min} \left[\frac{\frac{(4.955 \text{ kip})}{(0.65) \times (0.8)} - (0.85 \times (2.5 \text{ ksi}) \times (2304 \text{ in}^2))}{(60 \text{ ksi}) - (0.85 \times (2.5 \text{ ksi}))}, (0.08 \times (2304 \text{ in}^2)) \right]$$

$$A_{st,required} = -84.431 \text{ in}^2$$

A_{min} - Governing minimum reinforcement area,

$$A_{min} = \text{Max} [A_{st,required}, (0.0018 A_g)]$$

$$A_{min} = \text{Max} [(-84.431 \text{ in}^2), (0.0018 \times (2304 \text{ in}^2))]$$

$$A_{min} = 4.1472 \text{ in}^2$$

n_{rebar} - Required number of reinforcement,

$$n_{rebar} = \frac{A_{min}}{A_{rebar}}$$

$$n_{rebar} = \frac{(4.1472 \text{ in}^2)}{(0.3068 \text{ in}^2)}$$

$$n_{rebar} = 14$$

A_{st} - Actual total reinforcement area,

$$A_{st} = n_{rebar} \frac{\pi d_{bar}^2}{4}$$

$$A_{st} = (14) \times \frac{\pi \times (0.625 \text{ in})^2}{4}$$

$$A_{st} = 4.2951 \text{ in}^2$$

Ratio - Capacity

$$\text{Ratio} = \frac{A_{min}}{A_{st}}$$

$$\text{Ratio} = \frac{(4.1472 \text{ in}^2)}{(4.2951 \text{ in}^2)}$$

Table 22.4.2.1

22.4.2.2, 10.6.1.1

<p>25.2.3</p> <p>25.7.2.2</p> <p>25.7.2.1</p>	<p style="text-align: center;">$Ratio = 0.96556$</p> <p>$s_{rebar} = Max[1.5, (1.5 d_{bar})]$</p> <p>$s_{rebar} = Max[1.5, (1.5 \times (0.625 \text{ in}))]$</p> <p>$s_{rebar} = 1.5 \text{ in}$</p> <p>Ties:</p> <p>Since longitudinal reinforcement is \leq No. 10ø: Use #3(0.375 in)</p> <p>$s_{ties} = Min[(16 d_{bar}), (48 d_{ties}), Min(D, b)]$</p> <p>$s_{ties} = Min[(16 \times (0.625 \text{ in})), (48 \times (0.375 \text{ in})), Min((48 \text{ in}), (48 \text{ in}))]$</p> <p>$s_{ties} = 10 \text{ in}$</p> <p>Summary:</p> <p style="text-align: center;">Main reinforcement: 14 - #5 (0.625 in) Ties: #3(0.375 in) - 10 in</p>	<p>Status: PASS Ratio: 0.970</p>
<p>22.4.2.2</p>	<p>Axial Compression Strength (ACI 318-19, LRFD)</p> <p>ϕP_N - Allowable axial compressive strength</p> <p style="text-align: center;">$\phi P_N = \phi 0.80 [(0.85 f'_{ck} [A_g - A_{st}]) + (f_y A_{st})]$</p> <p style="text-align: center;">$\phi P_N = (0.65) \times 0.80 \times [(0.85 \times (2.5 \text{ ksi}) \times [(2304 \text{ in}^2) - (4.2951 \text{ in}^2)]) + ((60 \text{ ksi}) \times (4.2951 \text{ in}^2))]$</p> <p style="text-align: center;">$\phi P_N = 2675.2 \text{ kip}$</p> <p>Ratio - Capacity</p> <p style="text-align: center;">$Ratio = \frac{P}{\phi P_N}$</p> <p style="text-align: center;">$Ratio = \frac{(4.955 \text{ kip})}{(2675.2 \text{ kip})}$</p> <p style="text-align: center;">$Ratio = 0.0018522$</p>	<p>Status: PASS Ratio: 0.000</p>
<p>22.5.2.2</p> <p>22.5.5.1.3</p> <p>22.5.5.1.1</p>	<p>Shear Strength (ACI 318-19, LRFD)</p> <p>Parameters:</p> <p>$b_w = 48 \text{ in}$ - Effective width, d - Effective depth</p> <p style="text-align: center;">$d = 0.80 D$</p> <p style="text-align: center;">$d = 0.80 \times (48 \text{ in})$</p> <p style="text-align: center;">$d = 38.4 \text{ in}$</p> <p>λ_s - size effect modification factor</p> <p style="text-align: center;">$\lambda_s = MIN \left[\sqrt{\frac{2}{1 + \frac{d}{10}}}, 1 \right]$</p> <p style="text-align: center;">$\lambda_s = MIN \left[\sqrt{\frac{2}{1 + \frac{(38.4 \text{ in})}{10}}}, 1 \right]$</p> <p style="text-align: center;">$\lambda_s = 0.64282$</p> <p>The following variables were converted to be consistent with empirical formula $f'_{ck} = 2.5 \text{ ksi} \rightarrow 2500 \text{ psi}$,</p> <p>$V_{c,max}$ - Max shear strength of concrete</p> <p style="text-align: center;">$V_{c,max} = 5 \lambda_s \sqrt{f'_{ck}} b_w d$</p> <p style="text-align: center;">$V_{c,max} = 5 \times (0.64282) \times \sqrt{(2500 \text{ psi})} \times (48 \text{ in}) \times (38.4 \text{ in})$</p>	

$$V_{c,max} = 296.21 \text{ kip}$$

22.5.5.1.1(a) The following variables were converted to be consistent with empirical formula $f'_{ck} = 2.5 \text{ ksi} \rightarrow 2500 \text{ psi}$, $P = 4.955 \text{ kip} \rightarrow 4955 \text{ lbf}$,
 $V_{c,a}$ - Shear strength of concrete (a)

$$V_{c,a} = \left[2 \lambda_s \sqrt{f'_{ck} + \frac{P}{6 A_g}} \right] b_w d$$

$$V_{c,a} = \left[2 \times (0.64282) \times \sqrt{(2500 \text{ psi}) + \frac{(4955 \text{ lbf})}{6 \times (2304 \text{ in}^2)}} \right] \times (48 \text{ in}) \times (38.4 \text{ in})$$

$$V_{c,a} = 119.15 \text{ kip}$$

22.5.5.1.2 The following variables were converted to be consistent with empirical formula $f'_{ck} = 2.5 \text{ ksi} \rightarrow 2500 \text{ psi}$,
 $V_{c,b}$ - Shear strength of concrete (b)

$$V_{c,b} = \left[2 \lambda_s \sqrt{f'_{ck} + (0.05 f'_{ck})} \right] b_w d$$

$$V_{c,b} = \left[2 \times (0.64282) \times \sqrt{(2500 \text{ psi}) + (0.05 \times (2500 \text{ psi}))} \right] \times (48 \text{ in}) \times (38.4 \text{ in})$$

$$V_{c,b} = 348.89 \text{ kip}$$

V_c - Governing shear strength of concrete

$$V_c = \text{Min}[V_{c,max}, V_{c,a}, V_{c,b}]$$

$$V_c = \text{Min}[(296.21 \text{ kip}), (119.15 \text{ kip}), (348.89 \text{ kip})]$$

$$V_c = 119.15 \text{ kip}$$

22.5.5.1.2 The following variables were converted to be consistent with empirical formula $f'_{ck} = 2.5 \text{ ksi} \rightarrow 2500 \text{ psi}$,
 $V_{s,a}$ - Shear strength of steel (a)

$$V_{s,a} = 8 \sqrt{f'_{ck}} b_w d$$

$$V_{s,a} = 8 \times \sqrt{(2500 \text{ psi})} \times (48 \text{ in}) \times (38.4 \text{ in})$$

$$V_{s,a} = 737.28 \text{ kip}$$

A_v - Ties rebar area,

$$A_v = \frac{\pi d_{ties}^2}{4}$$

$$A_v = \frac{\pi \times (0.375 \text{ in})^2}{4}$$

$$A_v = 0.11045 \text{ in}^2$$

22.5.8.5.3 $V_{s,b}$ - Shear strength of steel (b)

$$V_{s,b} = \frac{2 A_v f_{yw} d}{s_{ties}}$$

$$V_{s,b} = \frac{2 \times (0.11045 \text{ in}^2) \times (60 \text{ ksi}) \times (38.4 \text{ in})}{(10 \text{ in})}$$

$$V_{s,b} = 50.894 \text{ kip}$$

V_s - Governing shear strength of steel

$$V_s = \text{MIN}[V_{s,a}, V_{s,b}]$$

$$V_s = \text{MIN}[(737.28 \text{ kip}), (50.894 \text{ kip})]$$

$$V_s = 50.894 \text{ kip}$$

22.5.1.1 ϕV_n - Allowable shear strength

$$\phi V_n = \phi (V_c + V_s)$$

$$\phi V_n = (0.65) \times ((119.15 \text{ kip}) + (50.894 \text{ kip}))$$

$$\phi V_n = 110.53 \text{ kip}$$

Considering x-direction:

$V_{max} = 6.5643 \text{ kip}$ - Maximum shear force in the x-direction,

$Ratio$ - Capacity

$$Ratio = \frac{V_{max}}{\phi V_n}$$

$$Ratio = \frac{(6.5643 \text{ kip})}{(110.53 \text{ kip})}$$

$$Ratio = 0.059391$$

Considering z-direction:

$V_{max} = 0.20481 \text{ kip}$ - Maximum shear force in the z-direction,

$Ratio$ - Capacity

$$Ratio = \frac{V_{max}}{\phi V_n}$$

$$Ratio = \frac{(0.20481 \text{ kip})}{(110.53 \text{ kip})}$$

$$Ratio = 0.0018531$$

Status: **PASS**
Ratio: **0.060**

Status: **PASS**
Ratio: **0.000**

Flexural Strength (ACI 318-19, LRFD)

S_m - Section modulus

$$S_m = \frac{b D^2}{6}$$

$$S_m = \frac{(48 \text{ in}) \times (48 \text{ in})^2}{6}$$

$$S_m = 18432 \text{ in}^3$$

$\lambda = 1$ - Concrete modification factor (Normal concrete),

Allowable flexural strength:

M_n shall be the lesser of:

$\phi M_{n,1}$

$$\phi M_{n,1} = \phi \times 5 \times \lambda \times \sqrt{f'_c} \times S_m$$

$$\phi M_{n,1} = 0.65 \times 5 \times 1 \times \sqrt{(2.5 \text{ ksi})} \times 18432.001 \text{ in}^3$$

$$\phi M_{n,1} = 249.600 \text{ kipft}$$

14.5.2.1b

$\phi M_{n,2}$

$$\phi M_{n,2} = \phi \times 0.85 \times f'_c \times S_m$$

$$\phi M_{n,2} = (0.65) \times 0.85 \times (2.5 \text{ ksi}) \times (18432 \text{ in}^3)$$

$$\phi M_{n,2} = 2121.6 \text{ kipft}$$

Therefore,

ϕM_n - Allowable flexural strength,

$$\phi M_n = \text{MIN}[\phi M_{n,1}, \phi M_{n,2}]$$

$$\phi M_n = \text{MIN}[(249.6 \text{ kipft}), (2121.6 \text{ kipft})]$$

$$\phi M_n = 249.6 \text{ kipft}$$

Considering x-direction:

$M_{max} = 16.425 \text{ kipft}$ - Maximum moment in the x-direction,

$Ratio$ - Capacity

$$Ratio = \frac{M_{max}}{\phi M_n}$$

$$Ratio = \frac{(16.425 \text{ kipft})}{(249.6 \text{ kipft})}$$

$$Ratio = 0.065805$$

Status: **PASS**
Ratio: **0.070**

Considering z-direction:

$M_{max} = 0.47735 \text{ kipft}$ - Maximum moment in the z-direction,

$Ratio$ - Capacity

$$Ratio = \frac{M_{max}}{\phi M_n}$$

$$\text{Ratio} = \frac{(0.47735 \text{ kipft})}{(249.6 \text{ kipft})}$$

$$\text{Ratio} = 0.0019124$$

Status: **PASS**
Ratio: **0.000**