

# Your Project Calculations



Project Name: RES Wasilla

S3D Model Link:

[https://platform.skyciv.com/structural?preload\\_name=RES%20Wasilla&preload\\_path=Shared%20Enterprise%20Folder/MT\\_Solar\\_Projects/7\\_2023](https://platform.skyciv.com/structural?preload_name=RES%20Wasilla&preload_path=Shared%20Enterprise%20Folder/MT_Solar_Projects/7_2023)

Public Model Link:

[https://platform.skyciv.com/structural-viewer?project\\_id=i4qKdYZHYzp\)2glO2gd6M8nj8TMTTr56Phrs3RPjTMHGp430dWNHzsMaUiuCkihWV](https://platform.skyciv.com/structural-viewer?project_id=i4qKdYZHYzp)2glO2gd6M8nj8TMTTr56Phrs3RPjTMHGp430dWNHzsMaUiuCkihWV)

## Array Specification

<b>Product:</b>	Beam
<b>Unique ID:</b>	1P-0-10TOP-HD-72-L-4Hx3W-J5KI
<b>Duty Classification:</b>	HD
<b>Module Width:</b>	41.30 in
<b>Module Length:</b>	83.90in
<b>Number of Rows:</b>	4
<b>Number of Columns:</b>	3
<b>Total Number of Modules:</b>	12
<b>Desired Tilt Angle:</b>	60
<b>Front Edge Clearance:</b>	8
<b>Total Array Height at Tilt:</b>	19.99 ft
<b>Total Frame Length:</b>	19.50 ft
<b>Frame Weight:</b>	1173 lbs
<b>Array Dimensions N/S:</b>	13.93 ft
<b>Array Dimensions E/W:</b>	21.23 ft
<b>Rail Length:</b>	167.20 in
<b>Rail Spacing:</b>	3.50 ft
<b>Rail Check:</b>	Not Checked

## Support Specifications

<b>Pole Size:</b>	10in Pipe Sch 40
<b>Pole Length above Grade:</b>	14.03 ft
<b>Number of Poles:</b>	1
<b>Pole Spacing:</b>	0

## Foundation Specifications

<b>Foundation Type:</b>	Round
<b>Foundation Dimensions:</b>	Ø36 in
<b>Foundation Depth (below grade):</b>	Pile 1: 15.00 ft
<b>Foundation Volume:</b>	3.927 y <sup>3</sup>
<b>Foundation Result:</b>	<b>FAILED</b> Try increasing foundation size and/or type and re-running foundation design check on right panel.
<b>Mount Twist:</b>	0.000009 kip

## Site Info

<b>Risk Category:</b>	I
<b>Exposure:</b>	C
<b>Soil Classification:</b>	sand
<b>Site Location:</b>	Talkeetna, AK 99676, USA
<b>Wind Speed:</b>	108 mph
<b>Snow Load:</b>	120 psf
<b>Design Uplift Pressure:</b>	0.027277 ksf
<b>Design Downforce Pressure:</b>	-0.027277 ksf
<b>Design Snow Pressure:</b>	0.013196 ksf



### Design Disclaimer

This software should be used for preliminary designs and should not be used as a final design unless reviewed, verified and designed by a qualified structural engineer.

### AutoDesigner Input

```
{
  "wind_speed_override": null,
  "snow_load_override": null,
  "direct_snow_load": false,
  "product_type": "Beam",
  "project_id": "RES Wasilla",
  "site_address": "Talkeetna, AK 99676, USA",
  "module_width": 41.3,
  "module_length": 83.9,
  "number_rows": 4,
  "number_columns": 3,
  "pole_mount_section": "4_40",
  "core_pipe_width": 65,
  "core_pipe_section": "2_40",
  "adjuster_section": "2_40",
  "core_beam_height": 65,
  "core_beam_section": "HSS3x2x1/8",
  "main_pipe_section": "2_12GA",
  "pole_spacing": "15",
  "tilt_angle": 60,
  "ground_clearance": 8,
  "risk_category": "I",
  "exposure_category": "C",
  "frame_duty_override": "auto",
  "pole_override": "10_40",
  "soil_type": "sand",
  "customer_foundation_override": "36_Round",
  "foundation_type": "Round",
  "foundation_size": 36,
  "check_rails": false
}
```

### Design Notes:

- AISC Deflection checks are set to L/1 due to structure design intent
- Foundation Design and Sizing is approximate only

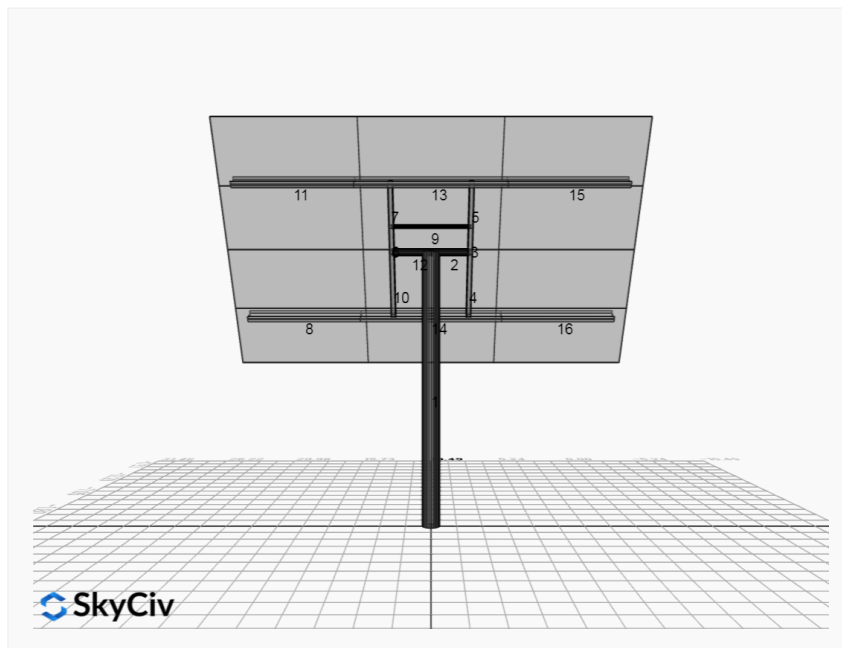

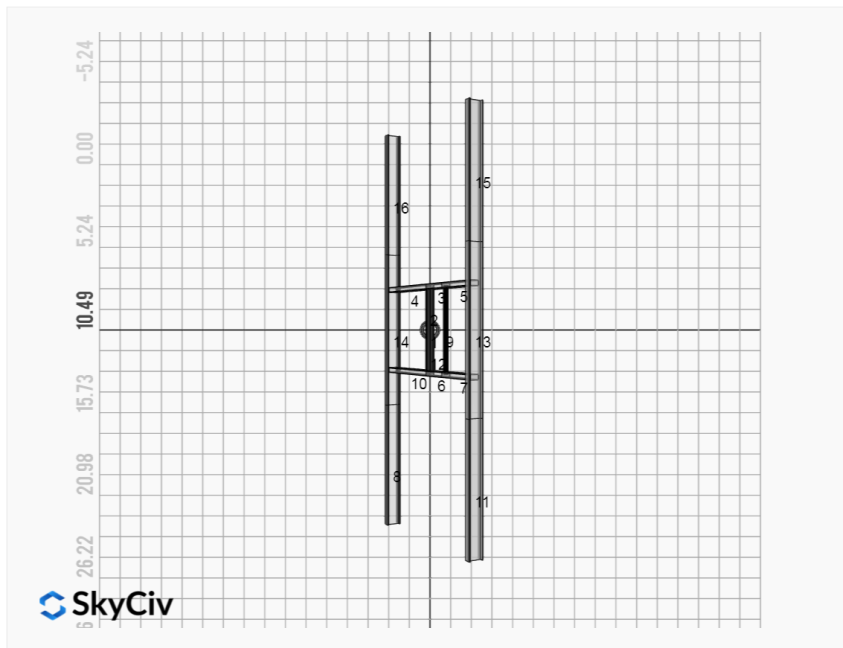
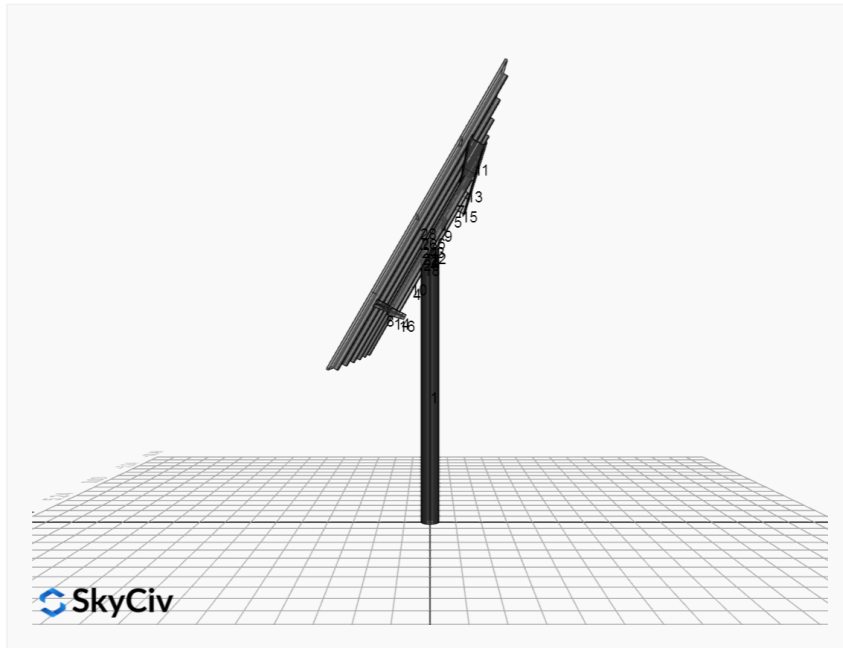

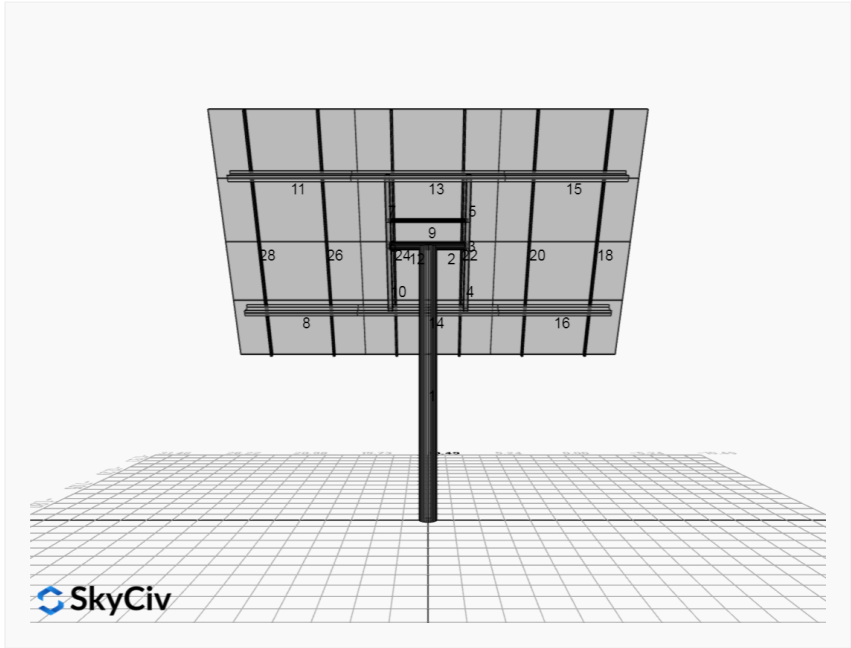
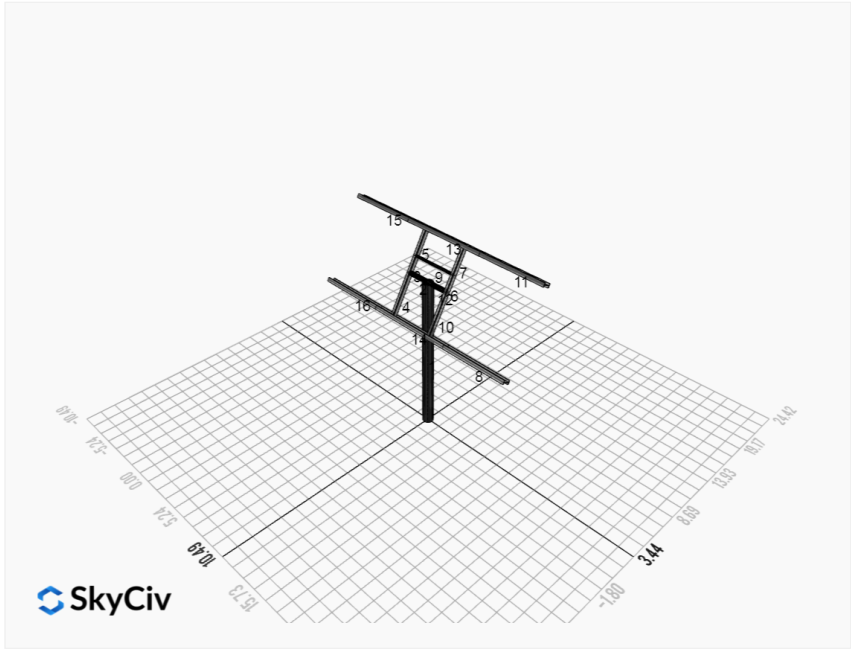

## FEM Results (Envelope Worst Case for each member)

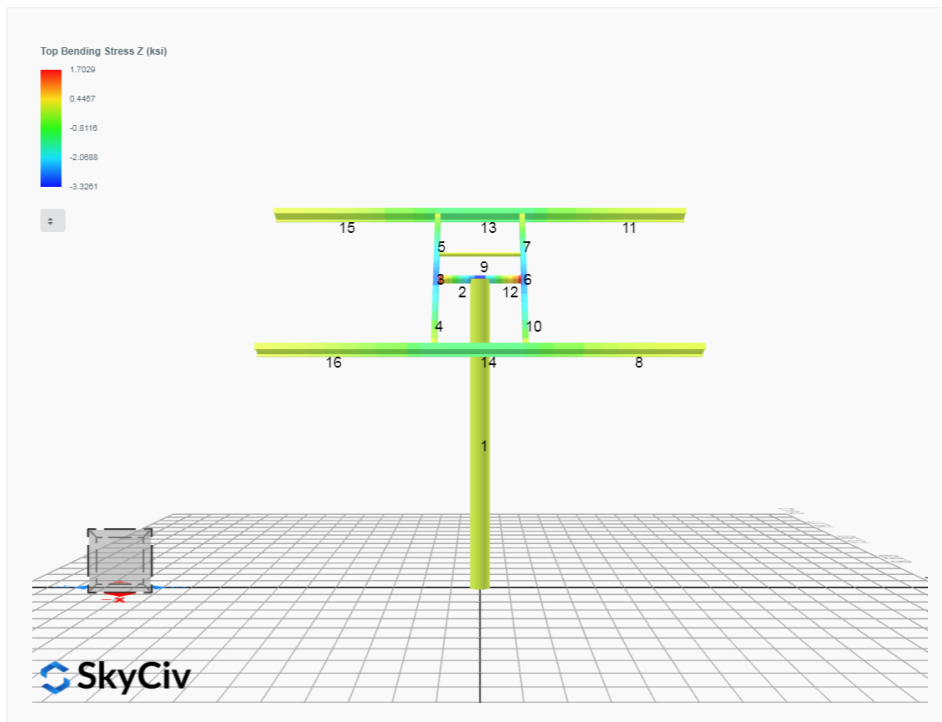
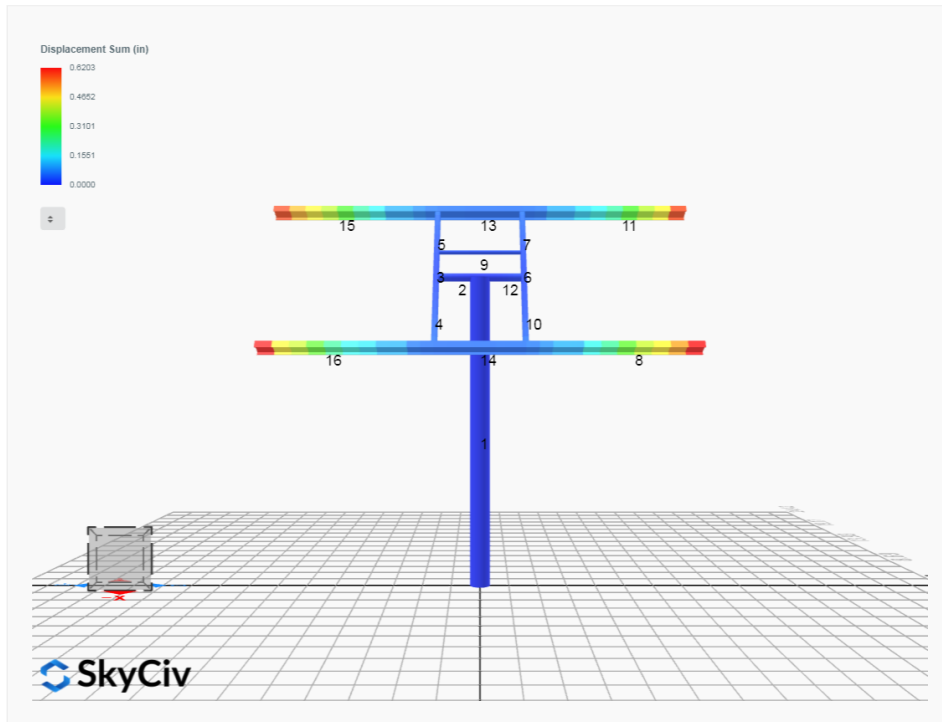

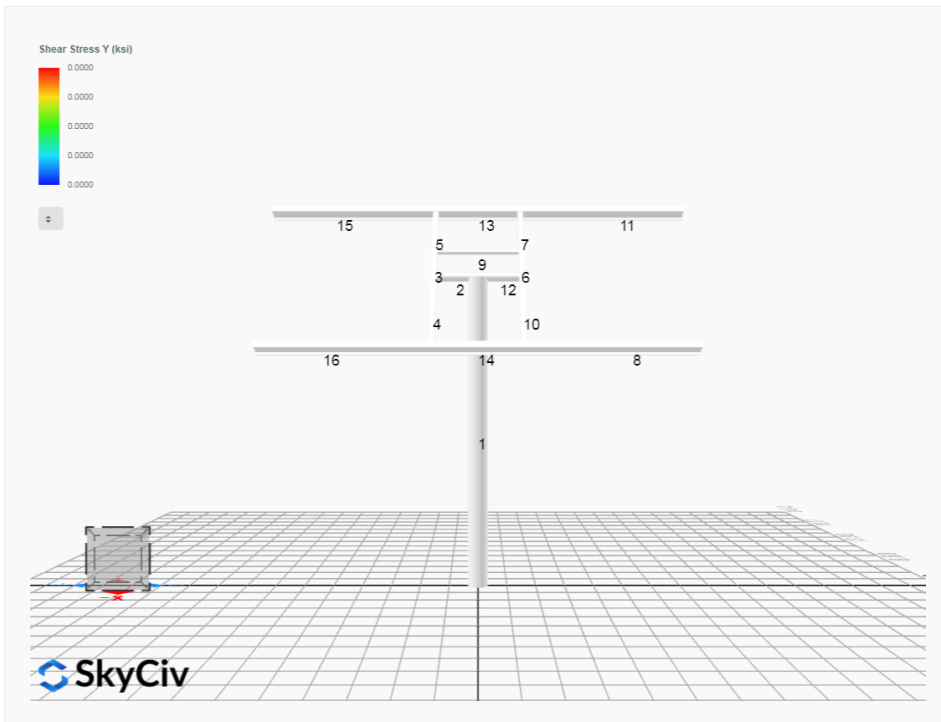
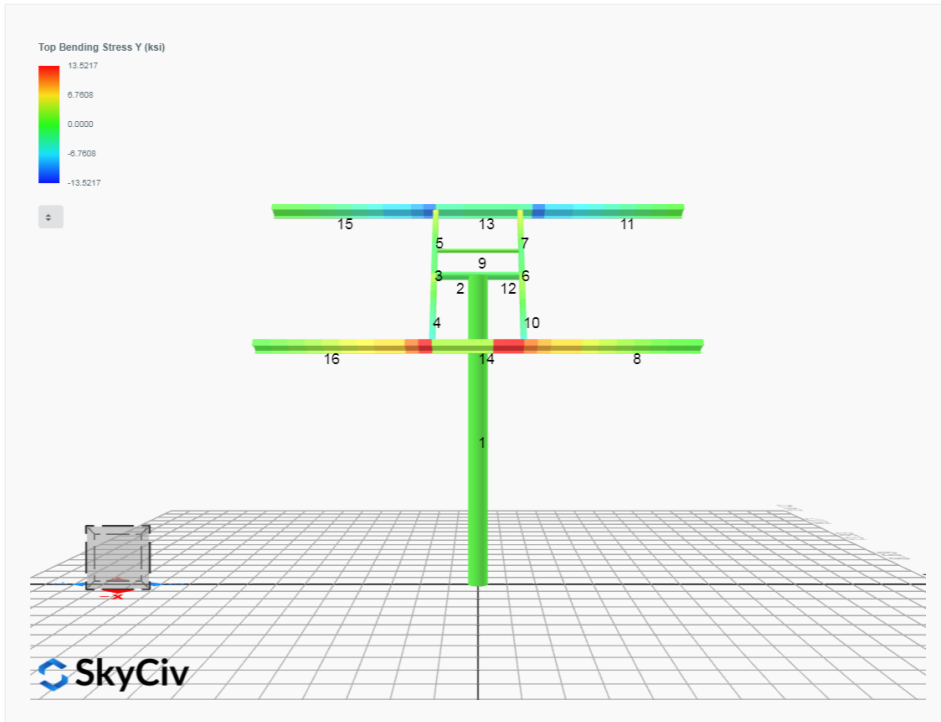

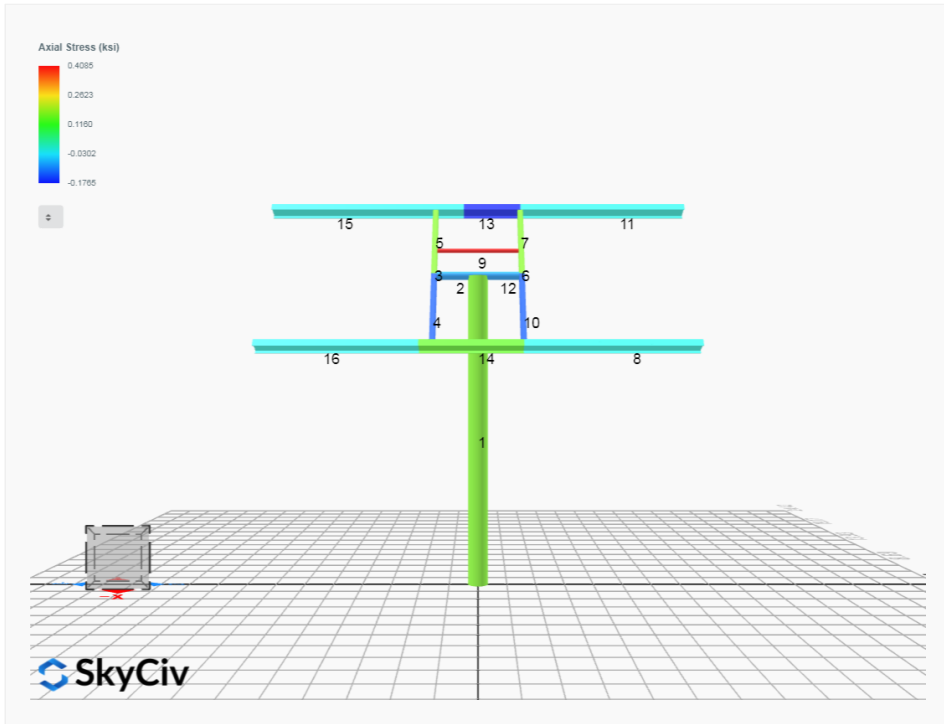

## Reaction Forces for Foundation 1 (Node ID#1), (kip, kip-ft)

### ASD Load Combination Results

Name	Fx	Fy	Fz	Mx	My	Mz
ULS: 1. D	-0.0000	2.5362	0.0000	0.0000	-0.0000	0.0166
ULS: 2. D + L	-0.0000	2.5362	0.0000	0.0000	-0.0000	0.0166
ULS: 3. D + (S or Lr or R)	-0.0000	4.3288	-0.0000	0.0000	-0.0000	0.0202
ULS: 3. D + (S or Lr or R)	-0.0000	2.5362	0.0000	0.0000	-0.0000	0.0166
ULS: 4. D + 0.75L + 0.75(S or Lr or R)	-0.0000	3.8807	-0.0000	0.0000	-0.0000	0.0193
ULS: 4. D + 0.75L + 0.75(S or Lr or R)	-0.0000	2.5362	0.0000	0.0000	-0.0000	0.0166
ULS: 5b. D + 0.7E	-0.0000	2.5362	0.0000	0.0000	-0.0000	0.0166
ULS: 6b. D + 0.75L + 0.75(0.7)E + 0.75S	-0.0000	3.8807	-0.0000	0.0000	-0.0000	0.0193
ULS: 8. 0.6D + 0.7E	-0.0000	1.5217	0.0000	0.0000	-0.0000	0.0100
ULS: 5a. D + 0.6W_Wind downforce Case A only	-4.1916	4.9562	-0.0000	0.0000	-0.0000	59.3252
ULS: 5a. D + 0.6W_Wind downforce Case B only	-0.0000	2.5362	0.0000	0.0000	-0.0000	0.0166
ULS: 5a. D + 0.6W_Wind uplift Case A only	4.1916	0.1161	-0.0000	0.0000	-0.0000	-58.3296
ULS: 5a. D + 0.6W_Wind uplift Case B only	-0.0000	2.5362	0.0000	0.0000	-0.0000	0.0166
ULS: 6a. D + 0.75L + 0.75(0.6)W + 0.75(S or Lr or R)_Wind downforce Case A only	-3.1437	5.6957	-0.0000	0.0000	-0.0000	44.5007
ULS: 6a. D + 0.75L + 0.75(0.6)W + 0.75(S or Lr or R)_Wind downforce Case B only	-0.0000	3.8807	-0.0000	0.0000	-0.0000	0.0193
ULS: 6a. D + 0.75L + 0.75(0.6)W + 0.75(S or Lr or R)_Wind uplift Case A only	3.1437	2.0656	-0.0000	0.0000	-0.0000	-43.7404
ULS: 6a. D + 0.75L + 0.75(0.6)W + 0.75(S or Lr or R)_Wind uplift Case B only	-0.0000	3.8807	-0.0000	0.0000	-0.0000	0.0193
ULS: 6a. D + 0.75L + 0.75(0.6)W + 0.75(S or Lr or R)_Wind downforce Case A only	-3.1437	4.3512	-0.0000	0.0000	-0.0000	44.4980
ULS: 6a. D + 0.75L + 0.75(0.6)W + 0.75(S or Lr or R)_Wind downforce Case B only	-0.0000	2.5362	0.0000	0.0000	-0.0000	0.0166
ULS: 6a. D + 0.75L + 0.75(0.6)W + 0.75(S or Lr or R)_Wind uplift Case A only	3.1437	0.7212	-0.0000	0.0000	-0.0000	-43.7431
ULS: 6a. D + 0.75L + 0.75(0.6)W + 0.75(S or Lr or R)_Wind uplift Case B only	-0.0000	2.5362	0.0000	0.0000	-0.0000	0.0166
ULS: 7. 0.6D + 0.6W_Wind downforce Case A only	-4.1916	3.9418	-0.0000	0.0000	-0.0000	59.3186
ULS: 7. 0.6D + 0.6W_Wind downforce Case B only	-0.0000	1.5217	0.0000	0.0000	-0.0000	0.0100
ULS: 7. 0.6D + 0.6W_Wind uplift Case A only	4.1916	-0.8983	-0.0000	0.0000	-0.0000	-58.3363
ULS: 7. 0.6D + 0.6W_Wind uplift Case B only	-0.0000	1.5217	0.0000	0.0000	-0.0000	0.0100

### Worst Case Reactions LRFD

These calculations are taken directly from the FEA via SkyCiv and are used in the Concrete Checks of the Foundation Module.  
Note: Worst case values are assumed as downforce wind load cases.

Result	Value (kip, kip-ft)
Axial	7.9732
Shear X	-6.9861
Shear Z	0.0000
Moment X	0.0000
Moment Y (Twist)	0.0000
Moment Z	99.7401

### Worst Case Reactions ASD

These results are taken from the worst case values in the above table and are used in the Soil Checks in the Foundation Module.  
Note: Worst case values are assumed as downforce wind load cases.

Result	Value (kip, kip-ft)
Axial	5.6957
Shear X	-4.1916
Shear Z	-0.0000
Moment X	0.0000
Moment Y (Twist)	0.0000
Moment Z	59.3252

## Project Details

Design Code: AISC 360-16 LRFD  
 Provision: LRFD  
 Country: United States

User Name: sales@mtsolar.us  
 Project Name: RES Wasilla  
 Unit System: imperial



## Design Input Information

Design Factors			
$\Phi_t$	$\Phi_c$	$\Phi_b$	$\Phi_v$
0.9	0.9	0.9	0.9

Design Materials			
ID	E (ksi)	F <sub>y</sub> (ksi)	F <sub>u</sub> (ksi)
1	29000	50	65

**Section Dimensions**

ID	Name	d (in)	t <sub>w</sub> (in)				
2	2in Pipe Sch 80	2.38	0.22				
5	4in Pipe Sch 80	4.50	0.34				
11	10in Pipe Sch 40	10.75	0.36				

ID	Name	d (in)	b (in)	t <sub>w</sub> (in)	t <sub>b</sub> (in)	r (in)	
16	HSS5x3x3/16	5.00	3.00	0.17	0.17	0.17	

ID	Name	d (in)	t <sub>w</sub> (in)	b <sub>t</sub> (in)	b <sub>b</sub> (in)	t <sub>t</sub> (in)	t <sub>b</sub> (in)	r (in)
19	W8x10	7.89	0.17	3.94	3.94	0.20	0.20	0.30

Section Properties								
ID	Name	A (in <sup>2</sup> )	J (in <sup>4</sup> )	I <sub>yp</sub> (in <sup>4</sup> )	I <sub>zp</sub> (in <sup>4</sup> )	I <sub>w</sub> (in <sup>6</sup> )	S <sub>yp</sub> (in <sup>3</sup> )	S <sub>zp</sub> (in <sup>3</sup> )
2	2in Pipe Sch 80	1.48	1.74	0.87	0.87	0.00	1.02	1.02
5	4in Pipe Sch 80	4.41	19.22	9.61	9.61	0.00	5.85	5.85



10	116.10	111.33	15.79	11.10	42.08	23.28
11	133.20	20.65	32.87	6.12	40.24	43.62
12	198.33	196.72	21.95	21.95	59.50	59.50
13	133.20	104.94	23.37	6.12	40.24	43.62
14	133.20	104.94	23.37	6.12	40.24	43.62
15	133.20	20.65	32.87	6.12	40.24	43.62
16	133.20	20.65	32.87	6.12	40.24	43.62

## Design Ratio

Member ID	P	M <sub>z</sub>	M <sub>y</sub>	V <sub>y</sub>	V <sub>z</sub>	(P,M <sub>z</sub> ,M <sub>y</sub> )	Worst LC	KL/r	δ	Status
1	0.029	0.675	0.000	0.043	0.000	0.690	#13	0.481	Not Required	Pass
2	0.006	0.266	0.312	0.061	0.059	0.580	#13	0.035	Not Required	Pass
3	0.010	0.576	0.059	0.057	0.008	0.601	#13	0.045	Not Required	Pass
4	0.010	0.573	0.230	0.057	0.046	0.658	#13	0.080	Not Required	Pass
5	0.010	0.357	0.240	0.057	0.062	0.398	#13	0.074	Not Required	Pass
6	0.010	0.576	0.059	0.057	0.008	0.601	#13	0.045	Not Required	Pass
7	0.010	0.357	0.240	0.057	0.062	0.398	#13	0.074	Not Required	Pass
8	0.000	0.134	0.325	0.037	0.015	0.417	#21	Not Required	Not Required	Pass
9	0.028	0.032	0.066	0.001	0.000	0.104	#13	0.204	Not Required	Pass
10	0.010	0.573	0.230	0.057	0.046	0.658	#13	0.080	Not Required	Pass
11	0.000	0.134	0.325	0.037	0.015	0.417	#21	Not Required	Not Required	Pass
12	0.006	0.266	0.312	0.061	0.059	0.580	#13	0.035	Not Required	Pass
13	0.011	0.325	0.542	0.047	0.020	0.757	#21	0.190	Not Required	Pass
14	0.010	0.329	0.542	0.047	0.020	0.757	#21	0.190	Not Required	Pass
15	0.000	0.134	0.325	0.037	0.015	0.417	#21	Not Required	Not Required	Pass
16	0.000	0.134	0.325	0.037	0.015	0.417	#21	Not Required	Not Required	Pass

## Definitions

$\Phi_t$	Safety factor for tensile
$\Phi_c$	Safety factor for compression
$\Phi_b$	Safety factor for flexure
$\Phi_v$	Safety factor for shear
E	Modulus of elasticity
F <sub>y</sub>	Specified minimum yield stress
F <sub>u</sub>	Specified minimum tensile strength
A	Cross-sectional area
J	Torsional constant
I <sub>yp</sub>	Moment of inertia about the Y axes
I <sub>zp</sub>	Moment of inertia about the Z axes
I <sub>w</sub>	Warping constant
S <sub>yp</sub>	Plastic section modulus about the Y axis
S <sub>zp</sub>	Plastic section modulus about the Z axis
KL	Effective length
C <sub>b</sub>	Buckling modification factor (from all load combinations)
L <sub>b</sub>	Length between braced points
LST	Limited slenderness for tension
LSC	Limited slenderness for compression
LD	Limited deflection
P <sub>n</sub>	Nominal axial strength (tension/compression)
M <sub>n</sub>	Nominal flexural strength (about Z/Y axis)
V <sub>n</sub>	Nominal shear strength (along Z/Y axis)
P	Design ratio in case of axial force
M <sub>z</sub>	Design ratio in case of bending about Z axis
M <sub>y</sub>	Design ratio in case of bending about Y axis
V <sub>y</sub>	Design ratio in case of shear along Y axis
V <sub>z</sub>	Design ratio in case of shear along Z axis
(P,M <sub>z</sub> ,M <sub>y</sub> )	Design ratio in case of axial force and bending action
KL/r	Design ratio in case of section slenderness
δ	Design ratio in case of member deflection
OK	Capacity is provided

ON  
NG

Capacity is provided  
Capacity is not provided

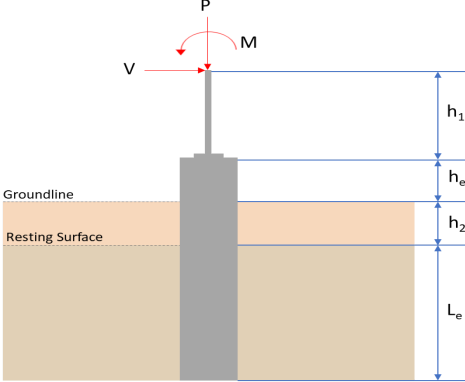
REFERENCES	CALCULATIONS	RESULTS																										
	<p><b>SkyCiv Foundation Design</b> Pile Foundation</p> <p><b>Design Information :</b> Design code : IBC 2021 (International Building Code) Unit System : Imperial</p>																											
	<p><b>Pile Input</b></p>  <p><b>Geometry</b> Pile shape: round <math>D = 36</math> in - Pile diameter <math>L = 15</math> ft - Total pile length <math>h_1 = 0</math> ft - Lateral load height from the top of the pile, <math>h_2 = 0</math> ft - Depth to resisting surface <math>h_e = 0</math> ft - Length of pile above the ground</p> <p><b>Tabulation of Soil Parameters</b></p> <table border="1" data-bbox="416 1079 1193 1171"> <thead> <tr> <th>Layer</th> <th>Label</th> <th>Allowable Bearing Pressure (<math>q_a</math>) (psf)</th> <th>Allowable Lateral Pressure (<math>R</math>) (psf/ft)</th> </tr> </thead> <tbody> <tr> <td>1</td> <td>Sand, silty sand, clayey sand, silty gravel &amp; clayey gravel</td> <td>2000.000</td> <td>150.000</td> </tr> </tbody> </table> <p><b>Tabulation of Loads</b></p> <table border="1" data-bbox="676 1265 935 1435"> <thead> <tr> <th>Load Component</th> <th>ASD</th> <th>LRFD</th> </tr> </thead> <tbody> <tr> <td><math>P</math> (kip)</td> <td>5.696</td> <td>7.973</td> </tr> <tr> <td><math>V_x</math> (kip)</td> <td>-4.192</td> <td>-6.986</td> </tr> <tr> <td><math>V_z</math> (kip)</td> <td>0.000</td> <td>0.000</td> </tr> <tr> <td><math>M_x</math> (kipft)</td> <td>0.000</td> <td>0.000</td> </tr> <tr> <td><math>M_z</math> (kipft)</td> <td>59.325</td> <td>99.740</td> </tr> </tbody> </table> <p><b>Material Properties</b> <math>f'_{ck} = 2.5</math> ksi - Concrete strength,</p>	Layer	Label	Allowable Bearing Pressure ( $q_a$ ) (psf)	Allowable Lateral Pressure ( $R$ ) (psf/ft)	1	Sand, silty sand, clayey sand, silty gravel & clayey gravel	2000.000	150.000	Load Component	ASD	LRFD	$P$ (kip)	5.696	7.973	$V_x$ (kip)	-4.192	-6.986	$V_z$ (kip)	0.000	0.000	$M_x$ (kipft)	0.000	0.000	$M_z$ (kipft)	59.325	99.740	
Layer	Label	Allowable Bearing Pressure ( $q_a$ ) (psf)	Allowable Lateral Pressure ( $R$ ) (psf/ft)																									
1	Sand, silty sand, clayey sand, silty gravel & clayey gravel	2000.000	150.000																									
Load Component	ASD	LRFD																										
$P$ (kip)	5.696	7.973																										
$V_x$ (kip)	-4.192	-6.986																										
$V_z$ (kip)	0.000	0.000																										
$M_x$ (kipft)	0.000	0.000																										
$M_z$ (kipft)	59.325	99.740																										
	<p><b>Required depth to resist lateral loads (ASD)</b> <math>H</math> - Point of application of the lateral load</p> $H = h_1 + h_2 + h_e$ $H = (0 \text{ ft}) + (0 \text{ ft}) + (0 \text{ ft})$ $H = 0 \text{ ft}$ <p><b>Considering x-direction:</b> <math>H_o</math> - Lateral force per length of pile,</p> $H_o = \frac{V_x}{D}$ $H_o = \frac{(-4.192 \text{ kip})}{(36 \text{ in})}$ $H_o = -1.3973 \text{ kip/ft}$ <p><math>M_o</math> - Moment per length of pile,</p> $M_o = \frac{M_z + (V_x H)}{D}$																											

	$M_o = \frac{(59.325 \text{ kipft}) + ((-4.192 \text{ kip}) \times (0 \text{ ft}))}{(36 \text{ in})}$ $M_o = 19.775 \text{ kipft/ft}$ <p>Required depth of embedment in earth:</p> $L_x^3 - \left(14.14 \times \frac{H_o \times L_x}{R}\right) - \left(18.85 \times \frac{M_o}{R}\right) = 0$ <p>Solving the cubic equation:  <math>L_{e,x} = 10.379 \text{ ft}</math> - Required depth in x-direction,</p> <p><b>Considering z-direction:</b>  <math>L_{e,z} = 0 \text{ ft}</math> - Required depth in z-direction,</p> <p><b>Minimum embedded depth required:</b>  <math>L_{e,req}</math> - Depth of pile required,</p> $L_{e,req} = \text{MAX}[L_{e,x}, L_{e,z}]$ $L_{e,req} = \text{MAX}[(10.379 \text{ ft}), (0 \text{ ft})]$ $L_{e,req} = 10.379 \text{ ft}$ <p><math>L_e</math> - Actual embedded length of pile,</p> $L_e = L - h_c - h_2$ $L_e = (15 \text{ ft}) - (0 \text{ ft}) - (0 \text{ ft})$ $L_e = 15 \text{ ft}$ <p>Ratio - Embedded depth</p> $\text{Ratio} = \frac{L_{e,req}}{L_e}$ $\text{Ratio} = \frac{(10.379 \text{ ft})}{(15 \text{ ft})}$ $\text{Ratio} = 0.69193$	<p>Status: <b>PASS</b>  Ratio: <b>0.690</b></p>
	<p><b>End-bearing Capacity (ASD)</b></p> <p><math>A</math> - Pile cross-section area</p> $A = \pi \left(\frac{D}{2}\right)^2$ $A = \pi \times \left(\frac{(36 \text{ in})}{2}\right)^2$ $A = 7.0686 \text{ ft}^2$ <p><math>q</math> - End-bearing pressure</p> $q = \frac{P_c}{A}$ $q = \frac{(5.696 \text{ kip})}{(7.0686 \text{ ft}^2)}$ $q = 0.80582 \text{ kip/ft}^2$ <p><b>Check bearing capacity ratio:</b></p> <p>Ratio - Capacity</p> $\text{Ratio} = \frac{q}{q_a}$ $\text{Ratio} = \frac{(0.80582 \text{ kip/ft}^2)}{(2000 \text{ psf})}$ $\text{Ratio} = 0.40291$	<p>Status: <b>PASS</b>  Ratio: <b>0.400</b></p>
Czerniak	<p><b>Lateral Soil Pressure (ASD):</b></p> <p><math>L/D</math> - Length to least lateral dimension ratio,</p> $L/D = \frac{L}{D}$ $L/D = \frac{(15 \text{ ft})}{(36 \text{ in})}$	

$$L/D = 5$$

Since  $L/D \leq 10$ ,

Pile is short.

**Considering x-direction:**

$H_o = -1.3973$  kip/ft - Lateral force per length of pile,

$M_o = 19.775$  kipft/ft - Overturning moment per length of pile,

$a$  - Distance from resting surface to pivot point,

$$a = \frac{(4 M_o L_e) + (3 H_o L_e^2)}{(6 M_o) + (4 H_o L_e)}$$

$$a = \frac{(4 \times (19.775 \text{ kipft/ft}) \times (15 \text{ ft})) + (3 \times (-1.3973 \text{ kip/ft}) \times (15 \text{ ft})^2)}{(6 \times (19.775 \text{ kipft/ft})) + (4 \times (-1.3973 \text{ kip/ft}) \times (15 \text{ ft}))}$$

$$a = 10.518 \text{ ft}$$

$p$  - Earth pressure against the pile at distance  $a/2$  from resting surface,

$$p = \frac{1.178 [(4 M_o) + (3 H_o L_e)]^2}{L_e^2 [(3 M_o) + (2 H_o L_e)]}$$

$$p = \frac{1.178 \times [(4 \times (19.775 \text{ kipft/ft})) + (3 \times (-1.3973 \text{ kip/ft}) \times (15 \text{ ft}))]^2}{(15 \text{ ft})^2 \times [(3 \times (19.775 \text{ kipft/ft})) + (2 \times (-1.3973 \text{ kip/ft}) \times (15 \text{ ft}))]}$$

$$p = 0.079139 \text{ kip/ft}^2$$

$s$  - Earth pressure against the pile at distance  $L_e$ ,

$$s = \frac{9.425 [(2 M_o) + (H_o L_e)]}{L_e^2}$$

$$s = \frac{9.425 \times [(2 \times (19.775 \text{ kipft/ft})) + ((-1.3973 \text{ kip/ft}) \times (15 \text{ ft}))]}{(15 \text{ ft})^2}$$

$$s = 0.77871 \text{ kip/ft}^2$$

**Check lateral soil pressure capacity:**

$p_a$  - Allowable lateral soil pressure at depth  $a/2$ ,

$$p_a = R \frac{a}{2}$$

$$p_a = (150 \text{ psf/ft}) \times \frac{(10.518 \text{ ft})}{2}$$

$$p_a = 0.78882 \text{ kip/ft}^2$$

Ratio - Lateral soil capacity

$$\text{Ratio} = \frac{p}{p_a}$$

$$\text{Ratio} = \frac{(0.079139 \text{ kip/ft}^2)}{(0.78882 \text{ kip/ft}^2)}$$

$$\text{Ratio} = 0.10033$$

$p_s$  - Allowable lateral soil pressure at depth  $L_e$ ,

$$p_s = R L_e$$

$$p_s = (150 \text{ psf/ft}) \times (15 \text{ ft})$$

$$p_s = 2.25 \text{ kip/ft}^2$$

Ratio - Lateral soil capacity

$$\text{Ratio} = \frac{s}{p_s}$$

$$\text{Ratio} = \frac{(0.77871 \text{ kip/ft}^2)}{(2.25 \text{ kip/ft}^2)}$$

$$\text{Ratio} = 0.3461$$

Status: **PASS**  
Ratio: **0.100**

Status: **PASS**  
Ratio: **0.350**

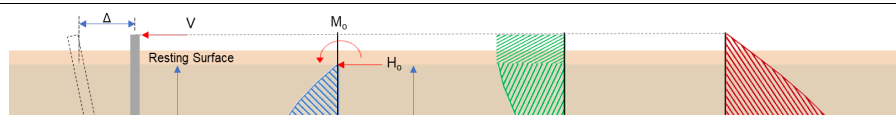

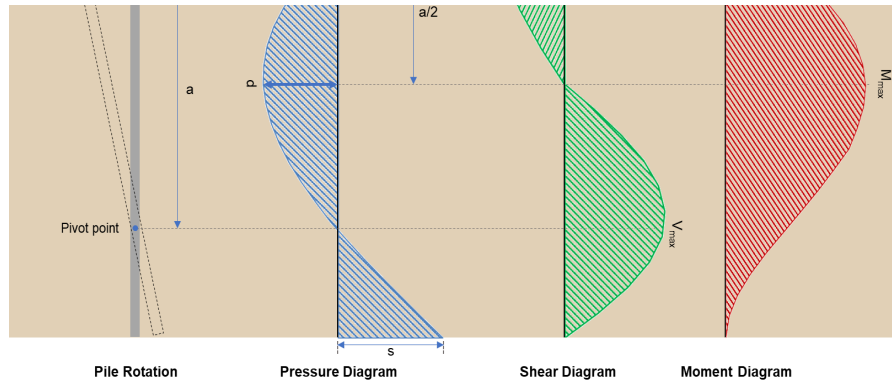

### Shear force and Bending moment (x-direction, LRFD)

$H_o$  - Lateral force per length of pile,

$$H_o = \frac{V_x}{D}$$

$$H_o = \frac{(-6.986 \text{ kip})}{(36 \text{ in})}$$

$$H_o = -2.3287 \text{ kip/ft}$$

$M_o$  - Moment per length of pile,

$$M_o = \frac{M_x + (V_x H)}{D}$$

$$M_o = \frac{(99.74 \text{ kipft}) + ((-6.986 \text{ kip}) \times (0 \text{ ft}))}{(36 \text{ in})}$$

$$M_o = 33.247 \text{ kipft/ft}$$

$E$  - Distance from lateral load to resisting surface,

$$E = \frac{M_o}{H_o}$$

$$E = \frac{(33.247 \text{ kipft/ft})}{(-2.3287 \text{ kip/ft})}$$

$$E = 14.277 \text{ ft}$$

$a$  - Distance from resting surface to pivot point,

$$a = \frac{(4 M_o L_c) + (3 H_o L_c^2)}{(6 M_o) + (4 H_o L_c)}$$

$$a = \frac{(4 \times (33.247 \text{ kipft/ft}) \times (15 \text{ ft})) + (3 \times (-2.3287 \text{ kip/ft}) \times (15 \text{ ft})^2)}{(6 \times (33.247 \text{ kipft/ft})) + (4 \times (-2.3287 \text{ kip/ft}) \times (15 \text{ ft}))}$$

$$a = 10.515 \text{ ft}$$

$V_{max}$  - Max shear force located at depth  $a$ ,

$$V_{max} = (H_o D) \left[ 1 - \left[ 3 \left( \frac{4 E}{L_c} + 3 \right) \left( \frac{a}{L_c} \right)^2 \right] + \left[ 4 \left( \frac{3 E}{L_c} + 2 \right) \left( \frac{a}{L_c} \right)^3 \right] \right]$$

$$V_{max} = ((-2.3287 \text{ kip/ft}) \times (36 \text{ in})) \times \left[ 1 - \left[ 3 \times \left( \frac{4 \times (14.277 \text{ ft})}{(15 \text{ ft})} + 3 \right) \times \left( \frac{(10.515 \text{ ft})}{(15 \text{ ft})} \right)^2 \right] + \left[ 4 \times \left( \frac{3 \times (14.277 \text{ ft})}{(15 \text{ ft})} + 2 \right) \times \left( \frac{(10.515 \text{ ft})}{(15 \text{ ft})} \right)^3 \right] \right]$$

$$V_{max} = 16.382 \text{ kip}$$

$M_{max}$  - Max bending moment located at depth  $a/2$ ,

$$M_{max} = (H_o D L_c) \left[ \left( \frac{E}{L_c} + \frac{a}{2 L_c} \right) - \left[ \left( \frac{4 E}{L_c} + 3 \right) \left( \frac{a}{2 L_c} \right)^3 \right] + \left[ \left( \frac{3 E}{L_c} + 2 \right) \left( \frac{a}{2 L_c} \right)^4 \right] \right]$$

$$M_{max} = ((-2.3287 \text{ kip/ft}) \times (36 \text{ in}) \times (15 \text{ ft})) \times \left[ \left( \frac{(14.277 \text{ ft})}{(15 \text{ ft})} + \frac{(10.515 \text{ ft})}{2 \times (15 \text{ ft})} \right) - \left[ \left( \frac{4 \times (14.277 \text{ ft})}{(15 \text{ ft})} + 3 \right) \times \left( \frac{(10.515 \text{ ft})}{2 \times (15 \text{ ft})} \right)^3 \right] + \left[ \left( \frac{3 \times (14.277 \text{ ft})}{(15 \text{ ft})} + 2 \right) \times \left( \frac{(10.515 \text{ ft})}{2 \times (15 \text{ ft})} \right)^4 \right] \right]$$

$$M_{max} = 113.43 \text{ kipft}$$

### Minimum Reinforcement Check (LRFD)

#### Parameters:

$f'_{ck} = 2.5 \text{ ksi}$  - Concrete strength,  
 $f_{yk} = 60 \text{ ksi}$  - Longitudinal reinforcement strength,  
 $\phi = 0.65$  - Reduction factor for axial strength,  
 $\alpha = 0.85$  - Alpha factor for axial strength,  
 $A_g = 1017.9 \text{ in}^2$  - Gross area of concrete,

Table 22.4.2.1

#### Longitudinal reinforcement:

Required reinforcement due to axial load,  $A_{st,required}$

22.4.2.2, 10.6.1.1

$A_{st,required}$

$$A_{st,required} = \text{Min} \left[ \frac{\frac{P}{\phi \alpha} - (0.85 f'_{ck} A_g)}{f_{yk} - (0.85 f'_{ck})}, (0.08 A_g) \right]$$

$$A_{st,required} = \text{Min} \left[ \frac{\frac{(7.973 \text{ kip})}{(0.65) \times (0.85)} - (0.85 \times (2.5 \text{ ksi}) \times (1017.9 \text{ in}^2))}{(60 \text{ ksi}) - (0.85 \times (2.5 \text{ ksi}))}, (0.08 \times (1017.9 \text{ in}^2)) \right]$$

$$A_{st,required} = -37.124 \text{ in}^2$$

$A_{min}$  - Governing minimum reinforcement area,

$$A_{min} = \text{Max} [A_{st,required}, (0.0018 A_g)]$$

$$A_{min} = \text{Max} [(-37.124 \text{ in}^2), (0.0018 \times (1017.9 \text{ in}^2))]$$

$$A_{min} = 1.8322 \text{ in}^2$$

$n_{rebar}$  - Required number of reinforcement,

$$n_{rebar} = \frac{A_{min}}{A_{rebar}}$$

$$n_{rebar} = \frac{(1.8322 \text{ in}^2)}{(0.3068 \text{ in}^2)}$$

$$n_{rebar} = 6$$

$A_{st}$  - Actual total reinforcement area,

$$A_{st} = n_{rebar} \frac{\pi d_{bar}^2}{4}$$

$$A_{st} = (6) \times \frac{\pi \times (0.625 \text{ in})^2}{4}$$

$$A_{st} = 1.8408 \text{ in}^2$$

Ratio - Capacity

$$\text{Ratio} = \frac{A_{min}}{A_{st}}$$

$$\text{Ratio} = \frac{(1.8322 \text{ in}^2)}{(1.8408 \text{ in}^2)}$$

$$\text{Ratio} = 0.99533$$

25.2.3

$s_{rebar}$  - Minimum spacing of reinforcement,

$$s_{rebar} = \text{Max} [1.5, (1.5 d_{bar})]$$

$$s_{rebar} = \text{Max} [1.5, (1.5 \times (0.625 \text{ in}))]$$

$$s_{rebar} = 1.5 \text{ in}$$

#### Ties:

25.7.2.2

Since longitudinal reinforcement is  $\leq$  No. 10Ø: Use #3(0.375 in)

25.7.2.1

$s_{ties}$  - Maximum center-to-center spacing of ties,

$$s_{ties} = \text{Min} [(16 d_{bar}), (48 d_{ties}), D]$$

$$s_{ties} = \text{Min} [(16 \times (0.625 \text{ in})), (48 \times (0.375 \text{ in})), (36 \text{ in})]$$

$$s_{ties} = 10 \text{ in}$$

#### Summary:

Status: **PASS**  
Ratio: **1.000**

Main reinforcement: **6 - #5 (0.625 in)**  
Ties: **#3(0.375 in) - 10 in**

**Axial Compression Strength (ACI 318-19, LRFD)**

22.4.2.2  $\phi P_N$  - Allowable axial compressive strength

$$\phi P_N = \phi 0.85 [(0.85 f'_{ck} [A_g - A_{st}]) + (f_{yk} A_{st})]$$

$$\phi P_N = (0.65) \times 0.85 \times [(0.85 \times (2.5 \text{ ksi}) \times [(1017.9 \text{ in}^2) - (1.8408 \text{ in}^2)]) + ((60 \text{ ksi}) \times (1.8408 \text{ in}^2))]$$

$$\phi P_N = 1253.9 \text{ kip}$$

Ratio - Capacity

$$\text{Ratio} = \frac{P}{\phi P_N}$$

$$\text{Ratio} = \frac{(7.973 \text{ kip})}{(1253.9 \text{ kip})}$$

$$\text{Ratio} = 0.0063585$$

Status: **PASS**  
Ratio: **0.010**

**Shear Strength (ACI 318-19, LRFD)**

**Parameters:**

$b_w = 36 \text{ in}$  - Effective width,  
22.5.2.2  $d$  - Effective depth

$$d = 0.80 D$$

$$d = 0.80 \times (36 \text{ in})$$

$$d = 28.8 \text{ in}$$

22.5.5.1.3  $\lambda_s$  - size effect modification factor

$$\lambda_s = \text{MIN} \left[ \sqrt{\frac{2}{1 + \frac{d}{10}}}, 1 \right]$$

$$\lambda_s = \text{MIN} \left[ \sqrt{\frac{2}{1 + \frac{(28.8 \text{ in})}{10}}}, 1 \right]$$

$$\lambda_s = 0.71796$$

The following variables were converted to be consistent with empirical formula  $f'_{ck} = 2.5 \text{ ksi} \rightarrow 2500 \text{ psi}$ .

22.5.5.1.1  $V_{c,max}$  - Max shear strength of concrete

$$V_{c,max} = 5 \lambda_s \sqrt{f'_{ck}} b_w d$$

$$V_{c,max} = 5 \times (0.71796) \times \sqrt{(2500 \text{ psi})} \times (36 \text{ in}) \times (28.8 \text{ in})$$

$$V_{c,max} = 186.09 \text{ kip}$$

The following variables were converted to be consistent with empirical formula  $f'_{ck} = 2.5 \text{ ksi} \rightarrow 2500 \text{ psi}$ ,  $P = 7.973 \text{ kip} \rightarrow 7973 \text{ lbf}$ .

22.5.5.1.1(a)  $V_{c,a}$  - Shear strength of concrete (a)

$$V_{c,a} = \left[ 2 \lambda_s \sqrt{f'_{ck}} + \frac{P}{6 A_g} \right] b_w d$$

$$V_{c,a} = \left[ 2 \times (0.71796) \times \sqrt{(2500 \text{ psi})} + \frac{(7973 \text{ lbf})}{6 \times (1017.9 \text{ in}^2)} \right] \times (36 \text{ in}) \times (28.8 \text{ in})$$

$$V_{c,a} = 75.791 \text{ kip}$$

The following variables were converted to be consistent with empirical formula  $f'_{ck} = 2.5 \text{ ksi} \rightarrow 2500 \text{ psi}$ .

22.5.5.1.2  $V_{c,b}$  - Shear strength of concrete (b)

$$V_{c,b} = \left[ 2 \lambda_s \sqrt{f'_{ck}} + (0.05 f'_{ck}) \right] b_w d$$

$$V_{c,b} = \left[ 2 \times (0.71796) \times \sqrt{(2500 \text{ psi})} + (0.05 \times (2500 \text{ psi})) \right] \times (36 \text{ in}) \times (28.8 \text{ in})$$

$$V_{c,b} = 204.04 \text{ kip}$$

$V_c$  - Governing shear strength of concrete

$$V_c = \text{Min} [V_{c,max}, V_{c,a}, V_{c,b}]$$

$$V_c = \text{Min} [(186.09 \text{ kip}), (75.791 \text{ kip}), (204.04 \text{ kip})]$$

<p>22.5.1.2</p> <p>22.5.8.5.3</p> <p>22.5.1.1</p>	<p style="text-align: center;"><math>V_c = 75.791 \text{ kip}</math></p> <p>The following variables were converted to be consistent with empirical formula <math>f'_{ck} = 2.5 \text{ ksi} \rightarrow 2500 \text{ psi}</math>.</p> <p><math>V_{s,a}</math> - Shear strength of steel (a)</p> $V_{s,a} = 8 \sqrt{f'_{ck}} b_w d$ $V_{s,a} = 8 \times \sqrt{(2500 \text{ psi})} \times (36 \text{ in}) \times (28.8 \text{ in})$ $V_{s,a} = 414.72 \text{ kip}$ <p><math>A_v</math> - Ties rebar area,</p> $A_v = \frac{\pi d_{ties}^2}{4}$ $A_v = \frac{\pi \times (0.375 \text{ in})^2}{4}$ $A_v = 0.11045 \text{ in}^2$ <p><math>V_{s,b}</math> - Shear strength of steel (b)</p> $V_{s,b} = \frac{2 A_v f_{yw} d}{s_{ties}}$ $V_{s,b} = \frac{2 \times (0.11045 \text{ in}^2) \times (60 \text{ ksi}) \times (28.8 \text{ in})}{(10 \text{ in})}$ $V_{s,b} = 38.17 \text{ kip}$ <p><math>V_s</math> - Governing shear strength of steel</p> $V_s = \text{MIN}[V_{s,a}, V_{s,b}]$ $V_s = \text{MIN}[(414.72 \text{ kip}), (38.17 \text{ kip})]$ $V_s = 38.17 \text{ kip}$ <p><math>\phi V_n</math> - Allowable shear strength</p> $\phi V_n = \phi (V_c + V_s)$ $\phi V_n = (0.65) \times ((75.791 \text{ kip}) + (38.17 \text{ kip}))$ $\phi V_n = 74.075 \text{ kip}$ <p><b>Considering x-direction:</b></p> <p><math>V_{max} = 16.382 \text{ kip}</math> - Maximum shear force in the x-direction,  <i>Ratio</i> - Capacity</p> $\text{Ratio} = \frac{V_{max}}{\phi V_n}$ $\text{Ratio} = \frac{(16.382 \text{ kip})}{(74.075 \text{ kip})}$ $\text{Ratio} = 0.22116$	<p>Status: <b>PASS</b>  Ratio: <b>0.220</b></p>
<p>14.5.2.1b</p>	<p><b>Flexural Strength (ACI 318-19, LRFD)</b></p> <p><math>S_m</math> - Section modulus</p> $S_m = \frac{\pi D^3}{32}$ $S_m = \frac{\pi \times (36 \text{ in})^3}{32}$ $S_m = 4580.4 \text{ in}^3$ <p><math>\lambda = 1</math> - Concrete modification factor (Normal concrete),  Allowable flexural strength:  <math>M_n</math> shall be the lesser of:</p> <p><math>\phi M_{n,1}</math></p> $\phi M_{n,1} = \phi \times 5 \times \lambda \times \sqrt{f'_c} \times S_m$ $\phi M_{n,1} = 0.65 \times 5 \times 1 \times \sqrt{(2.5 \text{ ksi})} \times 4580.442 \text{ in}^3$ $\phi M_{n,1} = 62.027 \text{ kipft}$ <p><math>\phi M_{n,2}</math></p>	

$$\phi M_{n,2} = \phi 0.85 f'_c S_m$$

$$\phi M_{n,2} = (0.65) \times 0.85 \times (2.5 \text{ ksi}) \times (4580.4 \text{ in}^3)$$

$$\phi M_{n,2} = 527.23 \text{ kipft}$$

Therefore,

$\phi M_n$  - Allowable flexural strength,

$$\phi M_n = \text{MIN}[\phi M_{n,1}, \phi M_{n,2}]$$

$$\phi M_n = \text{MIN}[(62.027 \text{ kipft}), (527.23 \text{ kipft})]$$

$$\phi M_n = 62.027 \text{ kipft}$$

**Considering x-direction:**

$M_{max} = 113.43 \text{ kipft}$  - Maximum moment in the x-direction,

*Ratio* - Capacity

$$\text{Ratio} = \frac{M_{max}}{\phi M_n}$$

$$\text{Ratio} = \frac{(113.43 \text{ kipft})}{(62.027 \text{ kipft})}$$

$$\text{Ratio} = 1.8288$$

Status: **FAIL**  
Ratio: **1.830**