

# Your Project Calculations



Project Name: neverve\_actual

S3D Model Link:

[https://platform.skyciv.com/structural?preload\\_name=neverve\\_actual&preload\\_path=Shared%20Enterprise%20Folder/MT\\_Solar\\_Projects/5\\_2023](https://platform.skyciv.com/structural?preload_name=neverve_actual&preload_path=Shared%20Enterprise%20Folder/MT_Solar_Projects/5_2023)

Public Model Link:

[https://platform.skyciv.com/structural-viewer?project\\_id=UNOXHGHi8kU74rzOe7pAXsDSazv2luMsbDuNn7xPh00iYm8U4H1tuGwvjKAS6nk](https://platform.skyciv.com/structural-viewer?project_id=UNOXHGHi8kU74rzOe7pAXsDSazv2luMsbDuNn7xPh00iYm8U4H1tuGwvjKAS6nk)

## Array Specification

<b>Product:</b>	Beam
<b>Unique ID:</b>	2P-15-6TOP-SD-12-L-4Hx4W-K3I5
<b>Duty Classification:</b>	SD
<b>Module Width:</b>	41.10 in
<b>Module Length:</b>	74.00in
<b>Number of Rows:</b>	4
<b>Number of Columns:</b>	4
<b>Total Number of Modules:</b>	16
<b>Desired Tilt Angle:</b>	40
<b>Front Edge Clearance:</b>	5
<b>Total Array Height at Tilt:</b>	13.86 ft
<b>Total Frame Length:</b>	24.50 ft
<b>Frame Weight:</b>	1102 lbs
<b>Array Dimensions N/S:</b>	13.87 ft
<b>Array Dimensions E/W:</b>	25.00 ft
<b>Rail Length:</b>	166.40 in
<b>Rail Spacing:</b>	3.08 ft
<b>Rail Check:</b>	Not Checked

## Support Specifications

<b>Pole Size:</b>	6in Pipe Sch 40
<b>Pole Length above Grade:</b>	9.46 ft
<b>Number of Poles:</b>	2
<b>Pole Spacing:</b>	15 ft

## Foundation Specifications

<b>Foundation Type:</b>	Square
<b>Foundation Dimensions:</b>	48 x 48 in
<b>Foundation Depth (below grade):</b>	Pile 1: 5.75 ft Pile 2: 5.75 ft
<b>Foundation Volume:</b>	6.815 y <sup>3</sup>
<b>Foundation Result:</b>	PASSED
<b>Mount Twist:</b>	0.583560 kip

## Site Info

<b>Risk Category:</b>	I
<b>Exposure:</b>	C
<b>Soil Classification:</b>	sand
<b>Site Location:</b>	101 N 4th St, Douglas, WY 82633, USA
<b>Wind Speed:</b>	102 mph
<b>Snow Load:</b>	25 psf
<b>Design Uplift Pressure:</b>	Multiple pressures
<b>Design Downforce Pressure:</b>	Multiple pressures
<b>Design Snow Pressure:</b>	0.008247 ksf



### Design Disclaimer

This software should be used for preliminary designs and should not be used as a final design unless reviewed, verified and designed by a qualified structural engineer.

### AutoDesigner Input

```
{
  "wind_speed_override": null,
  "snow_load_override": null,
  "direct_snow_load": false,
  "product_type": "Beam",
  "project_id": "neverve_actua
  l",
  "site_address": "101 N 4th St, Douglas, WY 82633,
  USA",
  "module_width": 41.1,
  "module_length": 74,
  "number_rows": "4",
  "number_columns": 4,
  "pole_mount_section": "4_40",
  "core_pipe_width": 6
  5,
  "core_pipe_section": "2_40",
  "adjuster_section": "2_40",
  "core_beam_height": 65,
  "core_beam_section": "HSS3x2x1/8",
  "main_pipe_section
  ": "2_12GA",
  "pole_spacing": "15",
  "tilt_angle": 40,
  "ground_clearance": 5,
  "risk_category": "I",
  "exposure_category": "C",
  "frame_duty_over
  ride": "auto",
  "pole_override": "auto",
  "soil_type": "sand",
  "foundation_type": "Square",
  "foundation_size": 48,
  "check_rails": false
}
```

### Design Notes:

- AISC Deflection checks are set to L/1 due to structure design intent
- Foundation Design and Sizing is approximate only

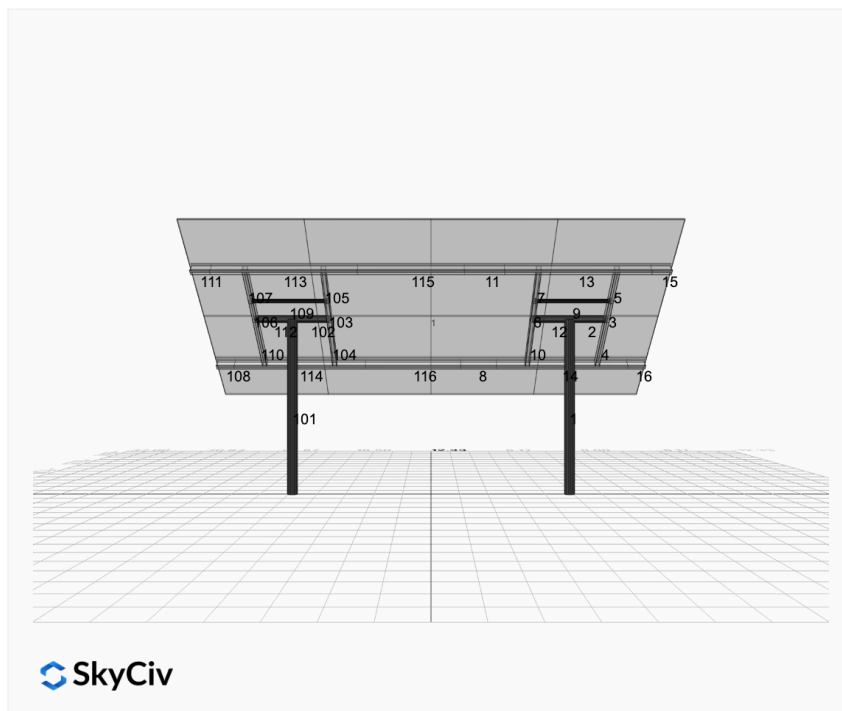

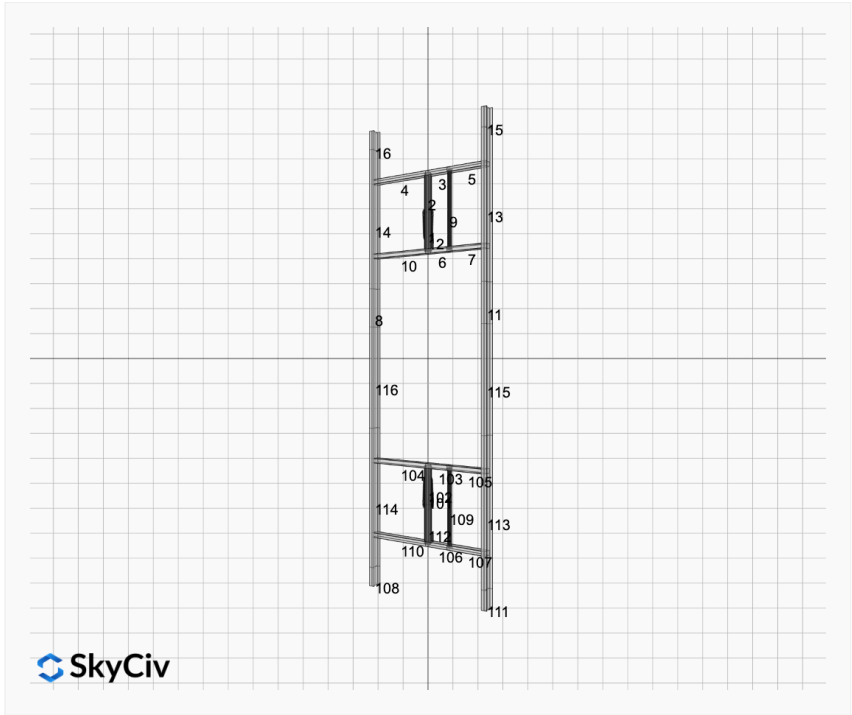
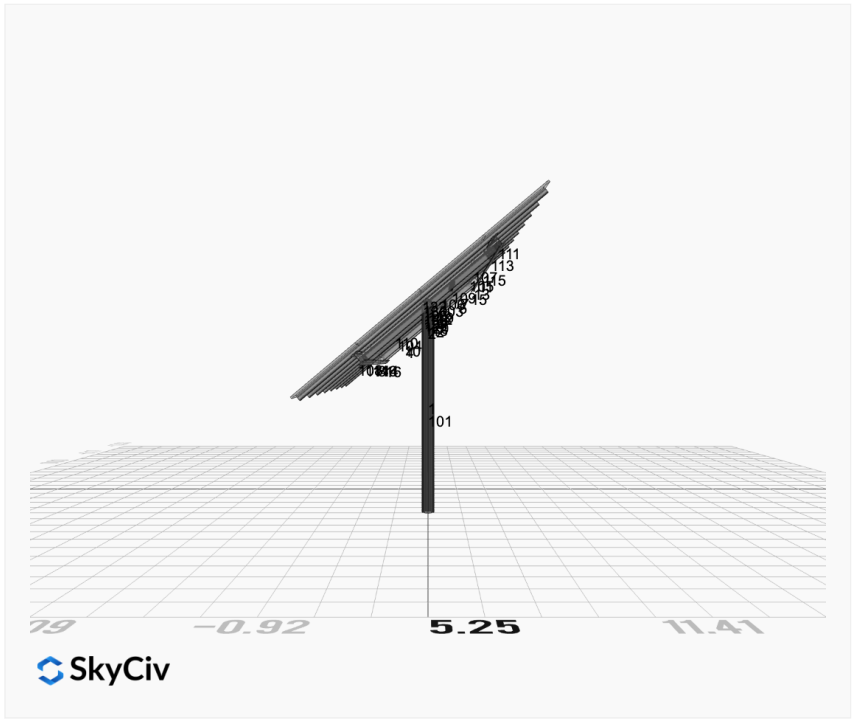

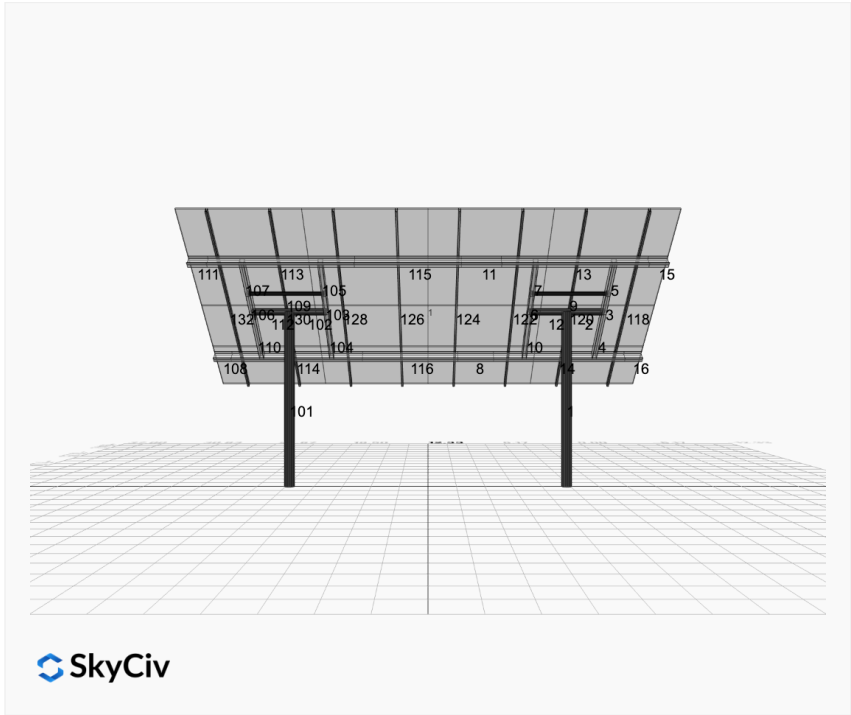
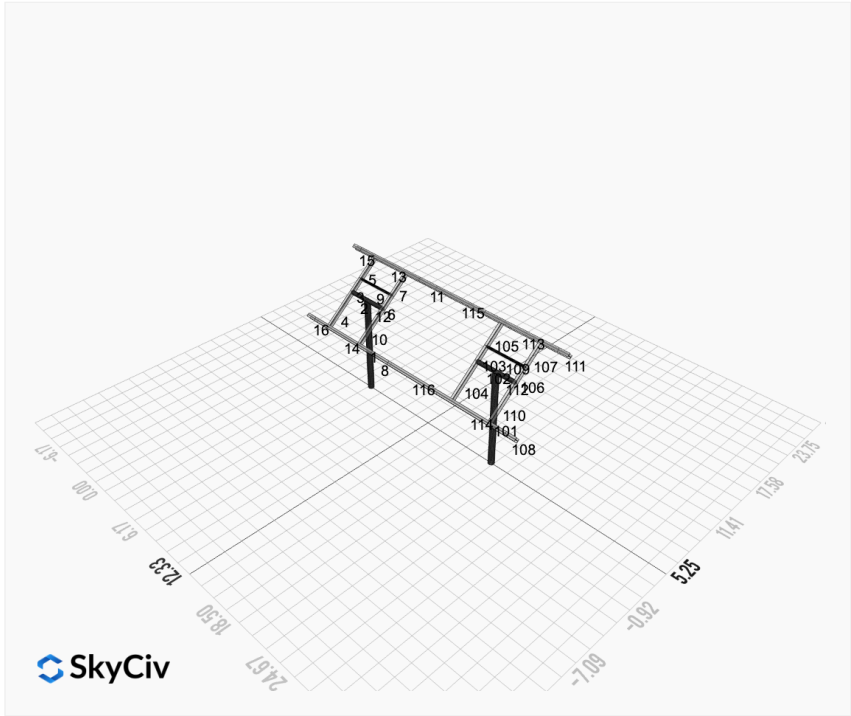

## FEM Results (Envelope Worst Case for each member)

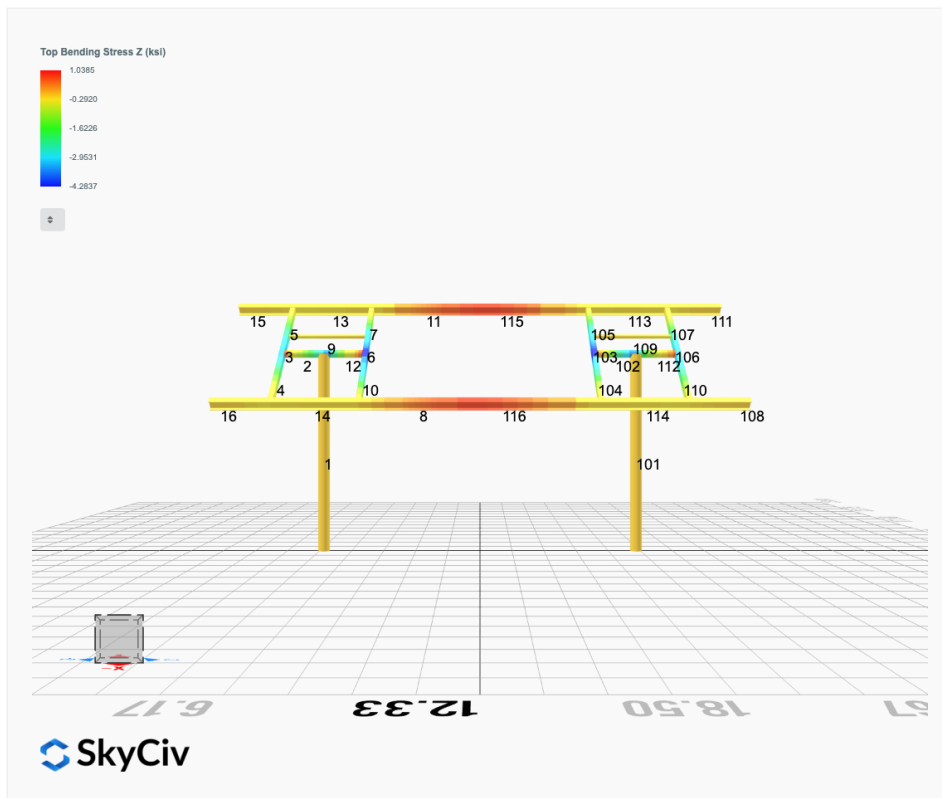
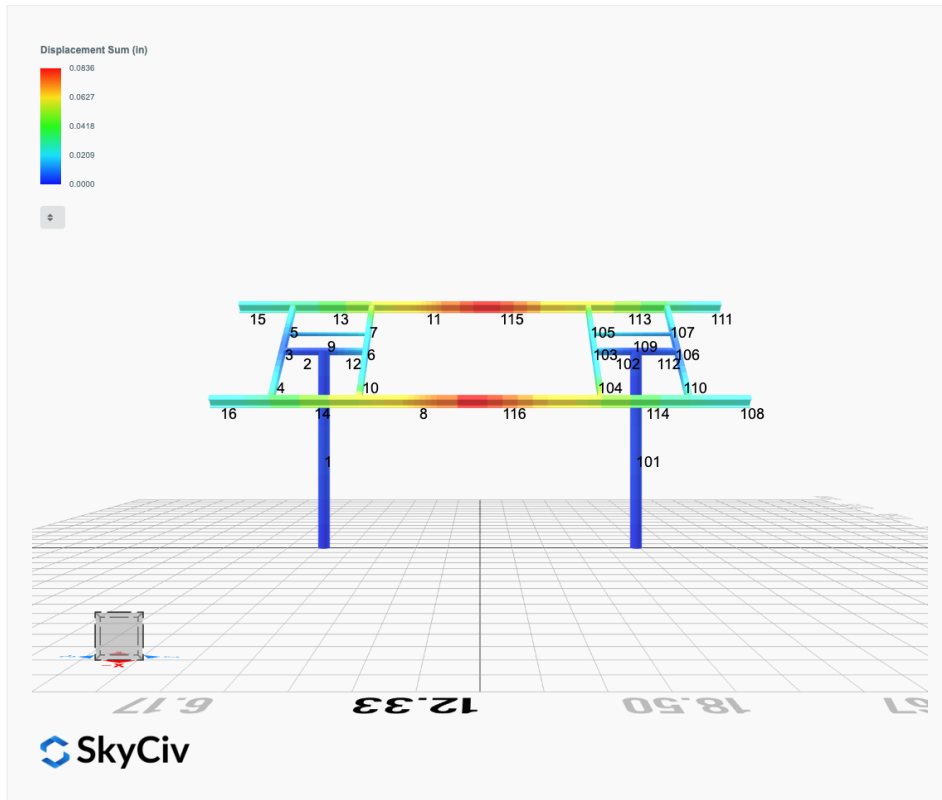

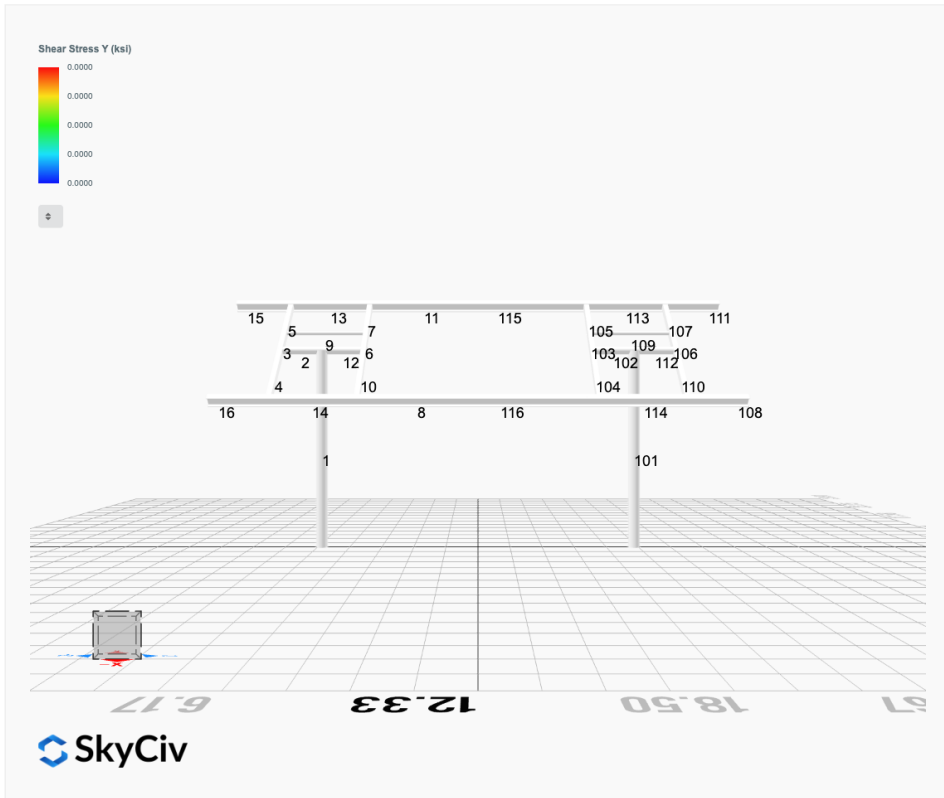
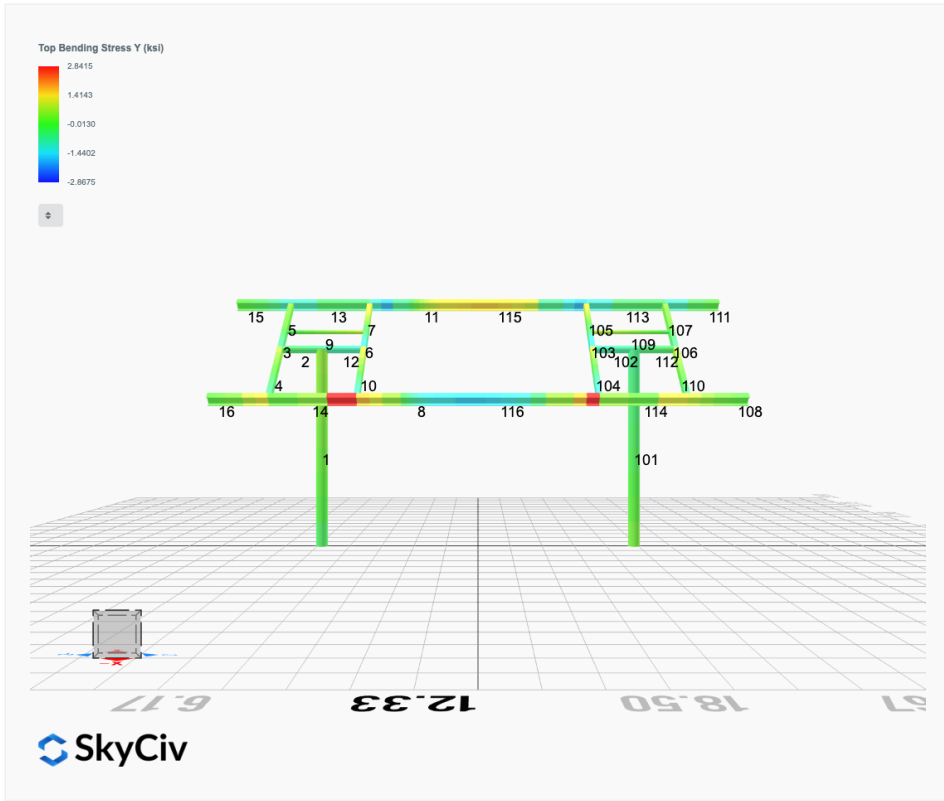

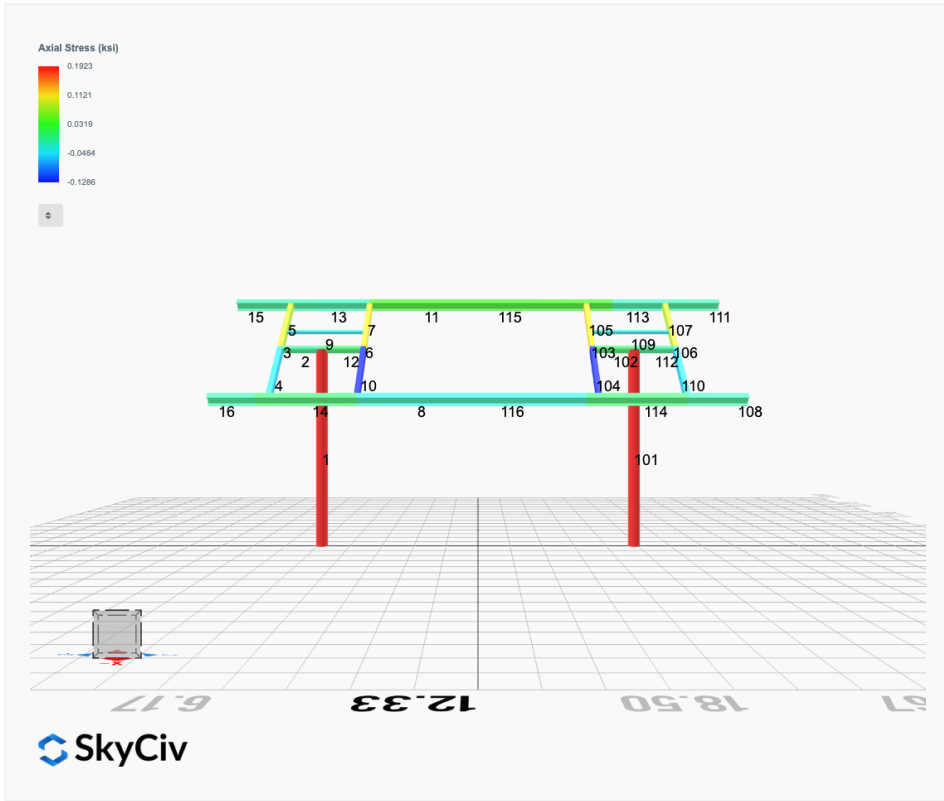

## Reaction Forces for Foundation 1 (Node ID#1), (kip, kip-ft)

### ASD Load Combination Results

Name	Fx	Fy	Fz	Mx	My	Mz
ULS: 1. D	0.0000	1.3645	0.0447	0.1283	-0.0346	0.0173
ULS: 2. D + L	0.0000	1.3645	0.0447	0.1283	-0.0346	0.0173
ULS: 3. D + (S or Lr or R)	0.0000	2.4377	0.0912	0.2617	-0.0707	0.0194
ULS: 3. D + (S or Lr or R)	0.0000	1.3645	0.0447	0.1283	-0.0346	0.0173
ULS: 4. D + 0.75L + 0.75(S or Lr or R)	0.0000	2.1694	0.0796	0.2283	-0.0617	0.0189
ULS: 4. D + 0.75L + 0.75(S or Lr or R)	0.0000	1.3645	0.0447	0.1283	-0.0346	0.0173
ULS: 5b. D + 0.7E	0.0000	1.3645	0.0447	0.1283	-0.0346	0.0173
ULS: 6b. D + 0.75L + 0.75(0.7)E + 0.75S	0.0000	2.1694	0.0796	0.2283	-0.0617	0.0189
ULS: 8. 0.6D + 0.7E	0.0000	0.8187	0.0268	0.0770	-0.0208	0.0104
ULS: 5a. D + 0.6W_Wind downforce Case A only	-2.0326	3.7868	0.1824	0.5087	-0.3496	20.1179
ULS: 5a. D + 0.6W_Wind downforce Case B only	-2.0326	3.7868	0.1824	0.5087	-0.3496	20.1179
ULS: 5a. D + 0.6W_Wind uplift Case A only	1.6199	-0.5660	-0.0645	-0.1727	0.2162	-14.8738
ULS: 5a. D + 0.6W_Wind uplift Case B only	1.3754	-0.2746	-0.0488	-0.1295	0.1801	-17.3439
ULS: 6a. D + 0.75L + 0.75(0.6)W + 0.75(S or Lr or R)_Wind downforce Case A only	-1.5244	3.9862	0.1828	0.5136	-0.2980	15.0944
ULS: 6a. D + 0.75L + 0.75(0.6)W + 0.75(S or Lr or R)_Wind downforce Case B only	-1.5244	3.9862	0.1828	0.5136	-0.2980	15.0944
ULS: 6a. D + 0.75L + 0.75(0.6)W + 0.75(S or Lr or R)_Wind uplift Case A only	1.2150	0.7215	-0.0023	0.0026	0.1264	-11.1494
ULS: 6a. D + 0.75L + 0.75(0.6)W + 0.75(S or Lr or R)_Wind uplift Case B only	1.0316	0.9400	0.0094	0.0350	0.0993	-13.0020
ULS: 6a. D + 0.75L + 0.75(0.6)W + 0.75(S or Lr or R)_Wind downforce Case A only	-1.5244	3.1813	0.1479	0.4136	-0.2709	15.0928
ULS: 6a. D + 0.75L + 0.75(0.6)W + 0.75(S or Lr or R)_Wind downforce Case B only	-1.5244	3.1813	0.1479	0.4136	-0.2709	15.0928
ULS: 6a. D + 0.75L + 0.75(0.6)W + 0.75(S or Lr or R)_Wind uplift Case A only	1.2150	-0.0834	-0.0372	-0.0974	0.1535	-11.1510
ULS: 6a. D + 0.75L + 0.75(0.6)W + 0.75(S or Lr or R)_Wind uplift Case B only	1.0316	0.1352	-0.0254	-0.0650	0.1264	-13.0036
ULS: 7. 0.6D + 0.6W_Wind downforce Case A only	-2.0326	3.2410	0.1645	0.4573	-0.3358	20.1110
ULS: 7. 0.6D + 0.6W_Wind downforce Case B only	-2.0326	3.2410	0.1645	0.4573	-0.3358	20.1110
ULS: 7. 0.6D + 0.6W_Wind uplift Case A only	1.6199	-1.1118	-0.0824	-0.2240	0.2300	-14.8807
ULS: 7. 0.6D + 0.6W_Wind uplift Case B only	1.3754	-0.8204	-0.0667	-0.1808	0.1939	-17.3508

### Worst Case Reactions LRFD

These calculations are taken directly from the FEA via SkyCiv and are used in the Concrete Checks of the Foundation Module.  
Note: Worst case values are assumed as downforce wind load cases.

Result	Value (kip, kip-ft)
Axial	6.2112
Shear X	-3.3876
Shear Z	0.3062
Moment X	0.8552
Moment Y (Twist)	0.5838
Moment Z	33.9571

### Worst Case Reactions ASD

These results are taken from the worst case values in the above table and are used in the Soil Checks in the Foundation Module.  
Note: Worst case values are assumed as downforce wind load cases.

Result	Value (kip, kip-ft)
Axial	3.9862
Shear X	-2.0326
Shear Z	0.1828
Moment X	0.5136
Moment Y (Twist)	0.3496
Moment Z	20.1179

## Reaction Forces for Foundation 2 (Node ID#101), (kip, kip-ft)

### ASD Load Combination Results

Name	Fx	Fy	Fz	Mx	My	Mz
ULS: 1. D	-0.0000	1.3645	-0.0447	-0.1283	0.0346	0.0173
ULS: 2. D + L	-0.0000	1.3645	-0.0447	-0.1283	0.0346	0.0173
ULS: 3. D + (S or Lr or R)	-0.0000	2.4377	-0.0912	-0.2617	0.0707	0.0194
ULS: 3. D + (S or Lr or R)	-0.0000	1.3645	-0.0447	-0.1283	0.0346	0.0173
ULS: 4. D + 0.75L + 0.75(S or Lr or R)	-0.0000	2.1694	-0.0796	-0.2283	0.0617	0.0189
ULS: 4. D + 0.75L + 0.75(S or Lr or R)	-0.0000	1.3645	-0.0447	-0.1283	0.0346	0.0173
ULS: 5b. D + 0.7E	-0.0000	1.3645	-0.0447	-0.1283	0.0346	0.0173

Name	Fx	Fy	Fz	Mx	My	Mz
ULS: 6b. D + 0.75L + 0.75(0.7)E + 0.75S	-0.0000	2.1694	-0.0796	-0.2283	0.0617	0.0189
ULS: 8. 0.6D + 0.7E	-0.0000	0.8187	-0.0268	-0.0770	0.0208	0.0104
ULS: 5a. D + 0.6W_Wind downforce Case A only	-2.0326	3.7868	-0.1824	-0.5086	0.3496	20.1179
ULS: 5a. D + 0.6W_Wind downforce Case B only	-2.0326	3.7868	-0.1824	-0.5086	0.3496	20.1179
ULS: 5a. D + 0.6W_Wind uplift Case A only	1.6199	-0.5660	0.0645	0.1727	-0.2162	-14.8738
ULS: 5a. D + 0.6W_Wind uplift Case B only	1.3754	-0.2746	0.0488	0.1295	-0.1801	-17.3439
ULS: 6a. D + 0.75L + 0.75(0.6)W + 0.75(S or Lr or R)_Wind downforce Case A only	-1.5244	3.9862	-0.1828	-0.5136	0.2980	15.0944
ULS: 6a. D + 0.75L + 0.75(0.6)W + 0.75(S or Lr or R)_Wind downforce Case B only	-1.5244	3.9862	-0.1828	-0.5136	0.2980	15.0944
ULS: 6a. D + 0.75L + 0.75(0.6)W + 0.75(S or Lr or R)_Wind uplift Case A only	1.2150	0.7215	0.0023	-0.0026	-0.1264	-11.1494
ULS: 6a. D + 0.75L + 0.75(0.6)W + 0.75(S or Lr or R)_Wind uplift Case B only	1.0316	0.9400	-0.0094	-0.0350	-0.0993	-13.0020
ULS: 6a. D + 0.75L + 0.75(0.6)W + 0.75(S or Lr or R)_Wind downforce Case A only	-1.5244	3.1813	-0.1479	-0.4136	0.2709	15.0928
ULS: 6a. D + 0.75L + 0.75(0.6)W + 0.75(S or Lr or R)_Wind downforce Case B only	-1.5244	3.1813	-0.1479	-0.4136	0.2709	15.0928
ULS: 6a. D + 0.75L + 0.75(0.6)W + 0.75(S or Lr or R)_Wind uplift Case A only	1.2150	-0.0834	0.0372	0.0974	-0.1535	-11.1510
ULS: 6a. D + 0.75L + 0.75(0.6)W + 0.75(S or Lr or R)_Wind uplift Case B only	1.0316	0.1352	0.0254	0.0650	-0.1264	-13.0036
ULS: 7. 0.6D + 0.6W_Wind downforce Case A only	-2.0326	3.2410	-0.1645	-0.4573	0.3358	20.1110
ULS: 7. 0.6D + 0.6W_Wind downforce Case B only	-2.0326	3.2410	-0.1645	-0.4573	0.3358	20.1110
ULS: 7. 0.6D + 0.6W_Wind uplift Case A only	1.6199	-1.1118	0.0824	0.2240	-0.2300	-14.8807
ULS: 7. 0.6D + 0.6W_Wind uplift Case B only	1.3754	-0.8204	0.0667	0.1808	-0.1939	-17.3508

#### Worst Case Reactions LRFD

These calculations are taken directly from the FEA via SkyCiv and are used in the Concrete Checks of the Foundation Module.  
Note: Worst case values are assumed as downforce wind load cases.

Result	Value (kip, kip-ft)
Axial	6.2112
Shear X	-3.3876
Shear Z	-0.3062
Moment X	-0.8553
Moment Y (Twist)	0.5836
Moment Z	33.9578

#### Worst Case Reactions ASD

These results are taken from the worst case values in the above table and are used in the Soil Checks in the Foundation Module.  
Note: Worst case values are assumed as downforce wind load cases.

Result	Value (kip, kip-ft)
Axial	3.9862
Shear X	-2.0326
Shear Z	-0.1828
Moment X	-0.5136
Moment Y (Twist)	0.3496
Moment Z	20.1179

## Project Details

Design Code: AISC 360-16 LRFD  
 Provision: LRFD  
 Country: United States  
 User Name: sales@mtsolar.us  
 Unit System: imperial



## Design Input Information

Design Factors			
$\Phi_t$	$\Phi_c$	$\Phi_b$	$\Phi_v$
0.9	0.9	0.9	0.9

Design Materials			
ID	E (ksi)	$F_y$ (ksi)	$F_u$ (ksi)
1	29000	50	65

### Section Dimensions



ID	Name	d (in)	$t_w$ (in)				
1	2in Pipe Sch 40	2.38	0.15				
4	4in Pipe Sch 40	4.50	0.24				
7	6in Pipe Sch 40	6.63	0.28				

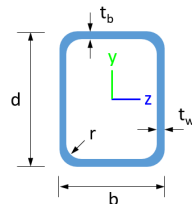

ID	Name	d (in)	b (in)	$t_w$ (in)	$t_b$ (in)	r (in)	
15	HSS5x3x1/8	5.00	3.00	0.12	0.12	0.12	



ID	Name	d (in)	$t_w$ (in)	$b_t$ (in)	$b_b$ (in)	$t_t$ (in)	$t_b$ (in)	r (in)
18	W6x9	5.90	0.17	3.94	3.94	0.21	0.21	0.25

### Section Properties

ID	Name	A (in <sup>2</sup> )	J (in <sup>4</sup> )	$I_{yp}$ (in <sup>4</sup> )	$I_{zp}$ (in <sup>4</sup> )	$I_w$ (in <sup>6</sup> )	$S_{yp}$ (in <sup>3</sup> )	$S_{zp}$ (in <sup>3</sup> )
1	2in Pipe Sch 40	1.07	1.33	0.67	0.67	0.00	0.76	0.76
4	4in Pipe Sch 40	3.17	14.47	7.23	7.23	0.00	4.31	4.31
7	6in Pipe Sch 40	5.58	56.28	28.14	28.14	0.00	11.28	11.28





115	120.00	102.67	20.96	6.45	30.09	45.74
116	120.60	102.67	20.96	6.45	30.09	45.74

## Design Ratio

Member ID	P	M <sub>z</sub>	M <sub>y</sub>	V <sub>y</sub>	V <sub>z</sub>	(P,M <sub>z</sub> ,M <sub>y</sub> )	Worst LC	KL/r	δ	Status
1	0.056	0.803	0.048	0.045	0.004	0.851	#13	0.531	Not Required	Pass
2	0.001	0.248	0.179	0.060	0.038	0.427	#13	0.052	Not Required	Pass
3	0.006	0.528	0.057	0.052	0.010	0.550	#13	0.044	Not Required	Pass
4	0.005	0.494	0.077	0.050	0.010	0.571	#13	0.078	Not Required	Pass
5	0.005	0.328	0.025	0.053	0.002	0.340	#13	0.073	Not Required	Pass
6	0.008	0.654	0.132	0.067	0.024	0.747	#13	0.044	Not Required	Pass
7	0.008	0.405	0.117	0.065	0.017	0.426	#13	0.073	Not Required	Pass
8	0.002	0.134	0.052	0.033	0.006	0.166	#13	0.088	Not Required	Pass
9	0.003	0.046	0.055	0.002	0.002	0.102	#13	0.132	Not Required	Pass
10	0.009	0.616	0.113	0.062	0.016	0.629	#13	0.078	Not Required	Pass
11	0.002	0.140	0.052	0.035	0.006	0.169	#13	0.088	Not Required	Pass
12	0.002	0.374	0.215	0.080	0.042	0.590	#13	0.167	Not Required	Pass
13	0.003	0.074	0.116	0.051	0.009	0.134	#21	0.265	Not Required	Pass
14	0.002	0.071	0.113	0.048	0.009	0.129	#21	0.177	Not Required	Pass
15	0.000	0.006	0.006	0.009	0.002	0.010	#21	Not Required	Not Required	Pass
16	0.000	0.006	0.006	0.009	0.002	0.010	#21	Not Required	Not Required	Pass
101	0.056	0.803	0.048	0.045	0.004	0.851	#13	0.531	Not Required	Pass
102	0.002	0.374	0.215	0.080	0.042	0.590	#13	0.167	Not Required	Pass
103	0.008	0.654	0.132	0.067	0.024	0.747	#13	0.044	Not Required	Pass
104	0.009	0.616	0.113	0.062	0.016	0.629	#13	0.078	Not Required	Pass
105	0.008	0.405	0.117	0.065	0.017	0.426	#13	0.073	Not Required	Pass
106	0.006	0.528	0.057	0.052	0.010	0.550	#13	0.044	Not Required	Pass
107	0.005	0.328	0.025	0.053	0.002	0.340	#13	0.073	Not Required	Pass
108	0.000	0.006	0.006	0.009	0.002	0.010	#21	Not Required	Not Required	Pass
109	0.003	0.046	0.055	0.002	0.002	0.102	#13	0.132	Not Required	Pass
110	0.005	0.494	0.077	0.050	0.010	0.571	#13	0.078	Not Required	Pass
111	0.000	0.006	0.006	0.009	0.002	0.010	#21	Not Required	Not Required	Pass
112	0.001	0.248	0.179	0.060	0.038	0.427	#13	0.052	Not Required	Pass
113	0.003	0.074	0.116	0.051	0.009	0.134	#21	0.177	Not Required	Pass
114	0.002	0.071	0.113	0.048	0.009	0.129	#21	0.265	Not Required	Pass
115	0.002	0.168	0.069	0.035	0.006	0.207	#13	0.235	Not Required	Pass
116	0.002	0.161	0.069	0.033	0.006	0.203	#13	0.235	Not Required	Pass

## Definitions

$\Phi_t$	Safety factor for tensile
$\Phi_c$	Safety factor for compression
$\Phi_b$	Safety factor for flexure
$\Phi_v$	Safety factor for shear
E	Modulus of elasticity
F <sub>y</sub>	Specified minimum yield stress
F <sub>u</sub>	Specified minimum tensile strength
A	Cross-sectional area
J	Torsional constant
I <sub>yp</sub>	Moment of inertia about the Y axes
I <sub>zp</sub>	Moment of inertia about the Z axes
I <sub>w</sub>	Warping constant
S <sub>yp</sub>	Plastic section modulus about the Y axis
S <sub>zp</sub>	Plastic section modulus about the Z axis
KL	Effective length
C <sub>b</sub>	Buckling modification factor (from all load combinations)
L <sub>b</sub>	Length between braced points

$L$	Length between brace points
LST	Limited slenderness for tension
LSC	Limited slenderness for compression
LD	Limited deflection
$P_n$	Nominal axial strength (tension/compression)
$M_n$	Nominal flexural strength (about Z/Y axis)
$V_n$	Nominal shear strength (along Z/Y axis)
P	Design ratio in case of axial force
$M_z$	Design ratio in case of bending about Z axis
$M_y$	Design ratio in case of bending about Y axis
$V_y$	Design ratio in case of shear along Y axis
$V_z$	Design ratio in case of shear along Z axis
$(P, M_z, M_y)$	Design ratio in case of axial force and bending action
$KL/r$	Design ratio in case of section slenderness
$\delta$	Design ratio in case of member deflection
OK	Capacity is provided
NG	Capacity is not provided

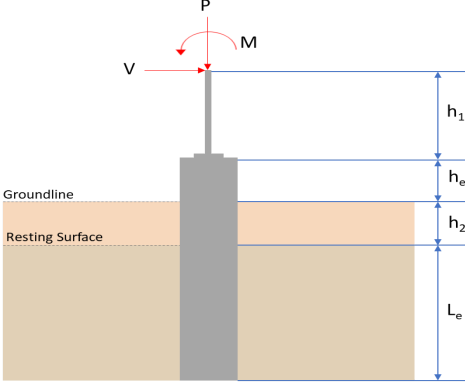
REFERENCES	CALCULATIONS	RESULTS																										
	<p><b>SkyCiv Foundation Design</b> Pile Foundation</p> <p><b>Design Information :</b> Design code : IBC 2021 (International Building Code) Unit System : Imperial</p>																											
	<p><b>Pile Input</b></p>  <p><b>Geometry</b> Pile shape: rectangular <math>b = 48</math> in - Pile width <math>D = 48</math> in - Pile depth <math>L = 5.75</math> ft - Total pile length <math>h_1 = 0</math> ft - Lateral load height from the top of the pile, <math>h_2 = 0</math> ft - Depth to resting surface <math>h_e = 0</math> ft - Length of pile above the ground</p> <p><b>Tabulation of Soil Parameters</b></p> <table border="1" data-bbox="416 1102 1193 1193"> <thead> <tr> <th>Layer</th> <th>Label</th> <th>Allowable Bearing Pressure (<math>q_a</math>) (psf)</th> <th>Allowable Lateral Pressure (<math>R</math>) (psf/ft)</th> </tr> </thead> <tbody> <tr> <td>1</td> <td>Sand, silty sand, clayey sand, silty gravel &amp; clayey gravel</td> <td>2000.000</td> <td>150.000</td> </tr> </tbody> </table> <p><b>Tabulation of Loads</b></p> <table border="1" data-bbox="676 1288 935 1458"> <thead> <tr> <th>Load Component</th> <th>ASD</th> <th>LRFD</th> </tr> </thead> <tbody> <tr> <td><math>P</math> (kip)</td> <td>3.986</td> <td>6.211</td> </tr> <tr> <td><math>V_x</math> (kip)</td> <td>-2.033</td> <td>-3.388</td> </tr> <tr> <td><math>V_z</math> (kip)</td> <td>0.183</td> <td>0.306</td> </tr> <tr> <td><math>M_x</math> (kipft)</td> <td>0.514</td> <td>0.855</td> </tr> <tr> <td><math>M_z</math> (kipft)</td> <td>20.118</td> <td>33.957</td> </tr> </tbody> </table> <p><b>Material Properties</b> <math>f'_{ck} = 3</math> ksi - Concrete strength,</p>	Layer	Label	Allowable Bearing Pressure ( $q_a$ ) (psf)	Allowable Lateral Pressure ( $R$ ) (psf/ft)	1	Sand, silty sand, clayey sand, silty gravel & clayey gravel	2000.000	150.000	Load Component	ASD	LRFD	$P$ (kip)	3.986	6.211	$V_x$ (kip)	-2.033	-3.388	$V_z$ (kip)	0.183	0.306	$M_x$ (kipft)	0.514	0.855	$M_z$ (kipft)	20.118	33.957	
Layer	Label	Allowable Bearing Pressure ( $q_a$ ) (psf)	Allowable Lateral Pressure ( $R$ ) (psf/ft)																									
1	Sand, silty sand, clayey sand, silty gravel & clayey gravel	2000.000	150.000																									
Load Component	ASD	LRFD																										
$P$ (kip)	3.986	6.211																										
$V_x$ (kip)	-2.033	-3.388																										
$V_z$ (kip)	0.183	0.306																										
$M_x$ (kipft)	0.514	0.855																										
$M_z$ (kipft)	20.118	33.957																										
	<p><b>Required depth to resist lateral loads (ASD)</b> <math>H</math> - Point of application of the lateral load</p> $H = h_1 + h_2 + h_e$ $H = (0 \text{ ft}) + (0 \text{ ft}) + (0 \text{ ft})$ $H = 0 \text{ ft}$ <p><b>Considering x-direction:</b> <math>H_o</math> - Lateral force per length of pile,</p> $H_o = \frac{V_x}{1.57 D}$ $H_o = \frac{(-2.033 \text{ kip})}{1.57 \times (48 \text{ in})}$ $H_o = -0.32373 \text{ kip/ft}$ <p><math>M_o</math> - Moment per length of pile,</p> $M_o = \frac{M_z + (V_x H)}{1.57 D}$																											

$$M_o = \frac{(20.118 \text{ kipft}) + ((-2.033 \text{ kip}) \times (0 \text{ ft}))}{1.57 \times (48 \text{ in})}$$

$$M_o = 3.2035 \text{ kipft/ft}$$

Required depth of embedment in earth:

$$L_x^3 - \left(14.14 \times \frac{H_o \times L_x}{R}\right) - \left(18.85 \times \frac{M_o}{R}\right) = 0$$

Solving the cubic equation:

$L_{e,x} = 5.3427 \text{ ft}$  - Required depth in x-direction,

**Considering z-direction:**

$H_o$  - Lateral force per length of pile,

$$H_o = \frac{V_z}{1.57 b}$$

$$H_o = \frac{(0.183 \text{ kip})}{1.57 \times (48 \text{ in})}$$

$$H_o = 0.02914 \text{ kip/ft}$$

$M_o$  - Moment per length of pile,

$$M_o = \frac{M_x + (V_z H)}{1.57 b}$$

$$M_o = \frac{(0.514 \text{ kipft}) + ((0.183 \text{ kip}) \times (0 \text{ ft}))}{1.57 \times (48 \text{ in})}$$

$$M_o = 0.081847 \text{ kipft/ft}$$

Required depth of embedment in earth:

$$L_z^3 - \left(14.14 \times \frac{H_o \times L_z}{R}\right) - \left(18.85 \times \frac{M_o}{R}\right) = 0$$

Solving the cubic equation:

$L_{e,z} = 2.1799 \text{ ft}$  - Required depth in z-direction,

**Minimum embedded depth required:**

$L_{e,req}$  - Depth of pile required,

$$L_{e,req} = \text{MAX}[L_{e,x}, L_{e,z}]$$

$$L_{e,req} = \text{MAX}[(5.3427 \text{ ft}), (2.1799 \text{ ft})]$$

$$L_{e,req} = 5.343 \text{ ft}$$

$L_e$  - Actual embedded length of pile,

$$L_e = L - h_e - h_2$$

$$L_e = (5.75 \text{ ft}) - (0 \text{ ft}) - (0 \text{ ft})$$

$$L_e = 5.75 \text{ ft}$$

**Ratio** - Embedded depth

$$\text{Ratio} = \frac{L_{e,req}}{L_e}$$

$$\text{Ratio} = \frac{(5.343 \text{ ft})}{(5.75 \text{ ft})}$$

$$\text{Ratio} = 0.92922$$

Status: **PASS**  
Ratio: **0.930**

**End-bearing Capacity (ASD)**

A - Pile cross-section area

$$A = b D$$

$$A = (48 \text{ in}) \times (48 \text{ in})$$

$$A = 16 \text{ ft}^2$$

q - End-bearing pressure

$$q = \frac{P_c}{A}$$

$$q = \frac{(3.986 \text{ kip})}{(16 \text{ ft}^2)}$$

$$q = 0.249125 \text{ kip/ft}^2$$

$$q = 0.24913 \text{ kip/ft}^2$$

**Check bearing capacity ratio:**

Ratio - Capacity

$$\text{Ratio} = \frac{q}{q_a}$$

$$\text{Ratio} = \frac{(0.24913 \text{ kip/ft}^2)}{(2000 \text{ psf})}$$

$$\text{Ratio} = 0.12456$$

Status: **PASS**  
Ratio: **0.120**

Czerniak

**Lateral Soil Pressure (ASD):**

$L/D$  - Length to least lateral dimension ratio,

$$L/D = \frac{L}{D}$$

$$L/D = \frac{(5.75 \text{ ft})}{(48 \text{ in})}$$

$$L/D = 1.4375$$

Since  $L/D \leq 10$ ,

Pile is short.

**Considering x-direction:**

$H_o = -0.32373 \text{ kip/ft}$  - Lateral force per length of pile,

$M_o = 3.2035 \text{ kipft/ft}$  - Overturning moment per length of pile,

$a$  - Distance from resting surface to pivot point,

$$a = \frac{(4 M_o L_e) + (3 H_o L_e^2)}{(6 M_o) + (4 H_o L_e)}$$

$$a = \frac{(4 \times (3.2035 \text{ kipft/ft}) \times (5.75 \text{ ft})) + (3 \times (-0.32373 \text{ kip/ft}) \times (5.75 \text{ ft})^2)}{(6 \times (3.2035 \text{ kipft/ft})) + (4 \times (-0.32373 \text{ kip/ft}) \times (5.75 \text{ ft}))}$$

$$a = 3.9671 \text{ ft}$$

$p$  - Earth pressure against the pile at distance  $a/2$  from resting surface,

$$p = \frac{0.75 [(4 M_o) + (3 H_o L_e)]^2}{L_e^2 [(3 M_o) + (2 H_o L_e)]}$$

$$p = \frac{0.75 \times [(4 \times (3.2035 \text{ kipft/ft})) + (3 \times (-0.32373 \text{ kip/ft}) \times (5.75 \text{ ft}))]^2}{(5.75 \text{ ft})^2 \times [(3 \times (3.2035 \text{ kipft/ft})) + (2 \times (-0.32373 \text{ kip/ft}) \times (5.75 \text{ ft}))]}$$

$$p = 0.20139 \text{ kip/ft}^2$$

$s$  - Earth pressure against the pile at distance  $L_e$ ,

$$s = \frac{6 [(2 M_o) + (H_o L_e)]}{L_e^2}$$

$$s = \frac{6 \times [(2 \times (3.2035 \text{ kipft/ft})) + ((-0.32373 \text{ kip/ft}) \times (5.75 \text{ ft}))]}{(5.75 \text{ ft})^2}$$

$$s = 0.82491 \text{ kip/ft}^2$$

**Check lateral soil pressure capacity:**

$p_a$  - Allowable lateral soil pressure at depth  $a/2$ ,

$$p_a = R \frac{a}{2}$$

$$p_a = (150 \text{ psf/ft}) \times \frac{(3.9671 \text{ ft})}{2}$$

$$p_a = 0.29753 \text{ kip/ft}^2$$

Ratio - Lateral soil capacity

$$\text{Ratio} = \frac{p}{p_a}$$

$$\text{Ratio} = \frac{(0.20139 \text{ kip/ft}^2)}{(0.29753 \text{ kip/ft}^2)}$$

$$\text{Ratio} = 0.67685$$

$p_a$  - Allowable lateral soil pressure at depth  $L_e$ ,

Status: **PASS**  
Ratio: **0.680**

	$p_s = R L_e$ $p_s = (150 \text{ psf/ft}) \times (5.75 \text{ ft})$ $p_s = 0.8625 \text{ kip/ft}^2$ <p>Ratio - Lateral soil capacity</p> $\text{Ratio} = \frac{s}{p_s}$ $\text{Ratio} = \frac{(0.82491 \text{ kip/ft}^2)}{(0.8625 \text{ kip/ft}^2)}$ $\text{Ratio} = 0.95641$	Status: <b>PASS</b> Ratio: <b>0.960</b>
	<p><b>Considering z-direction:</b></p> <p><math>H_o = 0.02914 \text{ kip/ft}</math> - Lateral force per length of pile,  <math>M_o = 0.081847 \text{ kipft/ft}</math> - Overturning moment per length of pile,  <math>a</math> - Distance from resting surface to pivot point,</p> $a = \frac{(4 M_o L_e) + (3 H_o L_e^2)}{(6 M_o) + (4 H_o L_e)}$ $a = \frac{(4 \times (0.081847 \text{ kipft/ft}) \times (5.75 \text{ ft})) + (3 \times (0.02914 \text{ kip/ft}) \times (5.75 \text{ ft})^2)}{(6 \times (0.081847 \text{ kipft/ft})) + (4 \times (0.02914 \text{ kip/ft}) \times (5.75 \text{ ft}))}$ $a = 4.1099 \text{ ft}$ <p><math>p</math> - Earth pressure against the pile at distance <math>a/2</math> from resting surface,</p> $p = \frac{0.75 [(4 M_o) + (3 H_o L_e)]^2}{L_e^2 [(3 M_o) + (2 H_o L_e)]}$ $p = \frac{0.75 \times [(4 \times (0.081847 \text{ kipft/ft})) + (3 \times (0.02914 \text{ kip/ft}) \times (5.75 \text{ ft}))]^2}{(5.75 \text{ ft})^2 \times [(3 \times (0.081847 \text{ kipft/ft})) + (2 \times (0.02914 \text{ kip/ft}) \times (5.75 \text{ ft}))]}$ $p = 0.026917 \text{ kip/ft}^2$ <p><math>s</math> - Earth pressure against the pile at distance <math>L_e</math>,</p> $s = \frac{6 [(2 M_o) + (H_o L_e)]}{L_e^2}$ $s = \frac{6 \times [(2 \times (0.081847 \text{ kipft/ft})) + ((0.02914 \text{ kip/ft}) \times (5.75 \text{ ft}))]}{(5.75 \text{ ft})^2}$ $s = 0.060113 \text{ kip/ft}^2$ <p><b>Check lateral soil pressure capacity:</b></p> <p><math>p_a</math> - Allowable lateral soil pressure at depth <math>a/2</math>,</p> $p_a = R \frac{a}{2}$ $p_a = (150 \text{ psf/ft}) \times \frac{(4.1099 \text{ ft})}{2}$ $p_a = 0.30824 \text{ kip/ft}^2$ <p>Ratio - Lateral soil capacity</p> $\text{Ratio} = \frac{p}{p_a}$ $\text{Ratio} = \frac{(0.026917 \text{ kip/ft}^2)}{(0.30824 \text{ kip/ft}^2)}$ $\text{Ratio} = 0.087324$ <p><math>p_s</math> - Allowable lateral soil pressure at depth <math>L_e</math>,</p> $p_s = R L_e$ $p_s = (150 \text{ psf/ft}) \times (5.75 \text{ ft})$ $p_s = 0.8625 \text{ kip/ft}^2$ <p>Ratio - Lateral soil capacity</p> $\text{Ratio} = \frac{s}{p_s}$	Status: <b>PASS</b> Ratio: <b>0.090</b>

$$Ratio = \frac{(0.060113 \text{ kip/ft}^2)}{(0.8625 \text{ kip/ft}^2)}$$

$$Ratio = 0.069697$$

Status: **PASS**  
Ratio: **0.070**

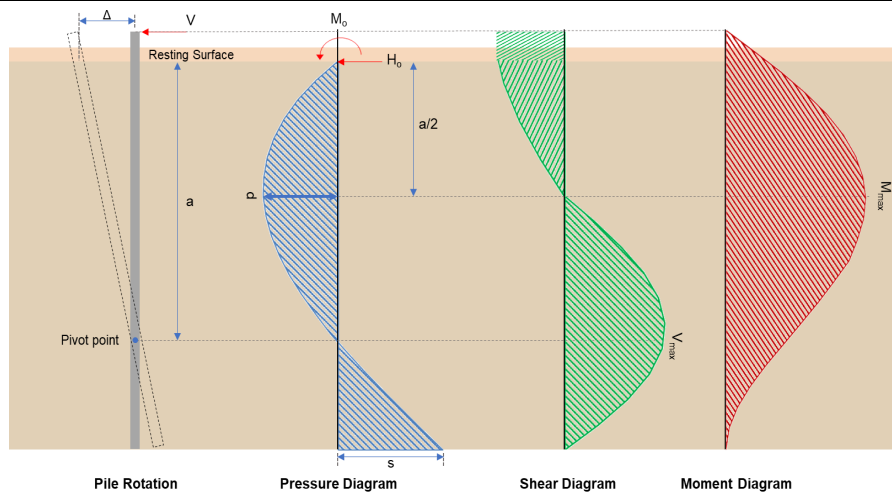

#### Shear force and Bending moment (x-direction, LRFD)

$H_o$  - Lateral force per length of pile,

$$H_o = \frac{V_e}{1.57 D}$$

$$H_o = \frac{(-3.388 \text{ kip})}{1.57 \times (48 \text{ in})}$$

$$H_o = -0.53949 \text{ kip/ft}$$

$M_o$  - Moment per length of pile,

$$M_o = \frac{M_z + (V_x H)}{1.57 D}$$

$$M_o = \frac{(33.957 \text{ kipft}) + ((-3.388 \text{ kip}) \times (0 \text{ ft}))}{1.57 \times (48 \text{ in})}$$

$$M_o = 5.4072 \text{ kipft/ft}$$

$E$  - Distance from lateral load to resisting surface,

$$E = \frac{M_o}{H_o}$$

$$E = \frac{(5.4072 \text{ kipft/ft})}{(-0.53949 \text{ kip/ft})}$$

$$E = 10.023 \text{ ft}$$

$a$  - Distance from resting surface to pivot point,

$$a = \frac{(4 M_o L_e) + (3 H_o L_e^2)}{(6 M_o) + (4 H_o L_e)}$$

$$a = \frac{(4 \times (5.4072 \text{ kipft/ft}) \times (5.75 \text{ ft})) + (3 \times (-0.53949 \text{ kip/ft}) \times (5.75 \text{ ft})^2)}{(6 \times (5.4072 \text{ kipft/ft})) + (4 \times (-0.53949 \text{ kip/ft}) \times (5.75 \text{ ft}))}$$

$$a = 3.9659 \text{ ft}$$

$V_{max}$  - Max shear force located at depth  $a$ ,

$$V_{max} = (H_o D) \left[ 1 - \left[ 3 \left( \frac{4 E}{L_e} + 3 \right) \left( \frac{a}{L_e} \right)^2 \right] + \left[ 4 \left( \frac{3 E}{L_e} + 2 \right) \left( \frac{a}{L_e} \right)^3 \right] \right]$$

$$V_{max} = ((-0.53949 \text{ kip/ft}) \times (48 \text{ in})) \times \left[ 1 - \left[ 3 \times \left( \frac{4 \times (10.023 \text{ ft})}{(5.75 \text{ ft})} + 3 \right) \times \left( \frac{(3.9659 \text{ ft})}{(5.75 \text{ ft})} \right)^2 \right] + \left[ 4 \times \left( \frac{3 \times (10.023 \text{ ft})}{(5.75 \text{ ft})} + 2 \right) \times \left( \frac{(3.9659 \text{ ft})}{(5.75 \text{ ft})} \right)^3 \right] \right]$$

$$V_{max} = 8.0794 \text{ kip}$$

$M_{max}$  - Max bending moment located at depth  $a/2$ ,

$$M_{max} = (H_o D L_e) \left[ \left( \frac{E}{L_e} + \frac{a}{2 L_e} \right) - \left[ \left( \frac{4 E}{L_e} + 3 \right) \left( \frac{a}{2 L_e} \right)^3 \right] + \left[ \left( \frac{3 E}{L_e} + 2 \right) \left( \frac{a}{2 L_e} \right)^4 \right] \right]$$

$$M_{max} = ((-0.53949 \text{ kip/ft}) \times (48 \text{ in}) \times (5.75 \text{ ft})) \times \left[ \left( \frac{(10.023 \text{ ft})}{(5.75 \text{ ft})} + \frac{(3.9659 \text{ ft})}{2 \times (5.75 \text{ ft})} \right) - \left[ \left( \frac{4 \times (10.023 \text{ ft})}{(5.75 \text{ ft})} + 3 \right) \times \left( \frac{(3.9659 \text{ ft})}{2 \times (5.75 \text{ ft})} \right)^3 \right] + \left[ \left( \frac{3 \times (10.023 \text{ ft})}{(5.75 \text{ ft})} + 2 \right) \times \left( \frac{(3.9659 \text{ ft})}{2 \times (5.75 \text{ ft})} \right)^4 \right] \right]$$

$$M_{max} = 22.102 \text{ kipft}$$

### Shear force and Bending moment (z-direction, LRFD)

$H_o$  - Lateral force per length of pile,

$$H_o = \frac{V_z}{1.57 b}$$

$$H_o = \frac{(0.306 \text{ kip})}{1.57 \times (48 \text{ in})}$$

$$H_o = 0.048726 \text{ kip/ft}$$

$M_o$  - Moment per length of pile,

$$M_o = \frac{M_x + (V_z H)}{1.57 b}$$

$$M_o = \frac{(0.855 \text{ kipft}) + ((0.306 \text{ kip}) \times (0 \text{ ft}))}{1.57 \times (48 \text{ in})}$$

$$M_o = 0.13615 \text{ kipft/ft}$$

$E$  - Distance from lateral load to resisting surface,

$$E = \frac{M_o}{H_o}$$

$$E = \frac{(0.13615 \text{ kipft/ft})}{(0.048726 \text{ kip/ft})}$$

$$E = 2.7941 \text{ ft}$$

$a$  - Distance from resting surface to pivot point,

$$a = \frac{(4 M_o L_e) + (3 H_o L_e^2)}{(6 M_o) + (4 H_o L_e)}$$

$$a = \frac{(4 \times (0.13615 \text{ kipft/ft}) \times (5.75 \text{ ft})) + (3 \times (0.048726 \text{ kip/ft}) \times (5.75 \text{ ft})^2)}{(6 \times (0.13615 \text{ kipft/ft})) + (4 \times (0.048726 \text{ kip/ft}) \times (5.75 \text{ ft}))}$$

$$a = 4.1105 \text{ ft}$$

$V_{max}$  - Max shear force located at depth  $a$ ,

$$V_{max} = (H_o b) \left[ 1 - \left[ 3 \left( \frac{4 E}{L_e} + 3 \right) \left( \frac{a}{L_e} \right)^2 \right] + \left[ 4 \left( \frac{3 E}{L_e} + 2 \right) \left( \frac{a}{L_e} \right)^3 \right] \right]$$

$$V_{max} = ((0.048726 \text{ kip/ft}) \times (48 \text{ in})) \times \left[ 1 - \left[ 3 \times \left( \frac{4 \times (2.7941 \text{ ft})}{(5.75 \text{ ft})} + 3 \right) \times \left( \frac{(4.1105 \text{ ft})}{(5.75 \text{ ft})} \right)^2 \right] + \left[ 4 \times \left( \frac{3 \times (2.7941 \text{ ft})}{(5.75 \text{ ft})} + 2 \right) \times \left( \frac{(4.1105 \text{ ft})}{(5.75 \text{ ft})} \right)^3 \right] \right]$$

$$V_{max} = 0.29751 \text{ kip}$$

$M_{max}$  - Max bending moment located at depth  $a/2$ ,

$$M_{max} = (H_o b L_e) \left[ \left( \frac{E}{L_e} + \frac{a}{2 L_e} \right) - \left[ \left( \frac{4 E}{L_e} + 3 \right) \left( \frac{a}{2 L_e} \right)^3 \right] + \left[ \left( \frac{3 E}{L_e} + 2 \right) \left( \frac{a}{2 L_e} \right)^4 \right] \right]$$

$$M_{max} = ((0.048726 \text{ kip/ft}) \times (48 \text{ in}) \times (5.75 \text{ ft})) \times \left[ \left( \frac{(2.7941 \text{ ft})}{(5.75 \text{ ft})} + \frac{(4.1105 \text{ ft})}{2 \times (5.75 \text{ ft})} \right) - \left[ \left( \frac{4 \times (2.7941 \text{ ft})}{(5.75 \text{ ft})} + 3 \right) \times \left( \frac{(4.1105 \text{ ft})}{2 \times (5.75 \text{ ft})} \right)^3 \right] + \left[ \left( \frac{3 \times (2.7941 \text{ ft})}{(5.75 \text{ ft})} + 2 \right) \times \left( \frac{(4.1105 \text{ ft})}{2 \times (5.75 \text{ ft})} \right)^4 \right] \right]$$

$$M_{max} = 0.75541 \text{ kipft}$$

### Minimum Reinforcement Check (LRFD)

#### Parameters:

$f'_{ck} = 3 \text{ ksi}$  - Concrete strength,  
 $f_{yk} = 60 \text{ ksi}$  - Longitudinal reinforcement strength,  
 $\phi = 0.65$  - Reduction factor for axial strength,  
 $\alpha = 0.8$  - Alpha factor for axial strength,  
 $A_g = 2304 \text{ in}^2$  - Gross area of concrete,

Table 22.4.2.1

#### Longitudinal reinforcement:

Required reinforcement due to axial load,  $A_{st,required}$

22.4.2.2, 10.6.1.1

$A_{st,required}$

$$A_{st,required} = \text{Min} \left[ \frac{\frac{P}{\phi \alpha} - (0.85 f'_{ck} A_g)}{f_{yk} - (0.85 f'_{ck})}, (0.08 A_g) \right]$$

$$A_{st,required} = \text{Min} \left[ \frac{\frac{(6.211 \text{ kip})}{(0.65) \times (0.8)} - (0.85 \times (3 \text{ ksi}) \times (2304 \text{ in}^2))}{(60 \text{ ksi}) - (0.85 \times (3 \text{ ksi}))}, (0.08 \times (2304 \text{ in}^2)) \right]$$

$$A_{st,required} = -102.06 \text{ in}^2$$

$A_{min}$  - Governing minimum reinforcement area,

$$A_{min} = \text{Max} [A_{st,required}, (0.0018 A_g)]$$

$$A_{min} = \text{Max} [(-102.06 \text{ in}^2), (0.0018 \times (2304 \text{ in}^2))]$$

$$A_{min} = 4.1472 \text{ in}^2$$

$n_{rebar}$  - Required number of reinforcement,

$$n_{rebar} = \frac{A_{min}}{A_{rebar}}$$

$$n_{rebar} = \frac{(4.1472 \text{ in}^2)}{(0.3068 \text{ in}^2)}$$

$$n_{rebar} = 14$$

$A_{st}$  - Actual total reinforcement area,

$$A_{st} = n_{rebar} \frac{\pi d_{bar}^2}{4}$$

$$A_{st} = (14) \times \frac{\pi \times (0.625 \text{ in})^2}{4}$$

$$A_{st} = 4.2951 \text{ in}^2$$

Ratio - Capacity

$$\text{Ratio} = \frac{A_{min}}{A_{st}}$$

$$\text{Ratio} = \frac{(4.1472 \text{ in}^2)}{(4.2951 \text{ in}^2)}$$

$$\text{Ratio} = 0.96556$$

Status: **PASS**  
Ratio: **0.970**

25.2.3

$s_{rebar}$  - Minimum spacing of reinforcement,

$$s_{rebar} = \text{Max} [1.5, (1.5 d_{bar})]$$

$$s_{rebar} = \text{Max} [1.5, (1.5 \times (0.625 \text{ in}))]$$

$$s_{rebar} = 1.5 \text{ in}$$

#### Ties:

25.7.2.2

Since longitudinal reinforcement is  $\leq$  No. 10: Use #3(0.375 in)

25.7.2.1

$s_{ties}$  - Maximum spacing of ties,

$$s_{ties} = \text{Min} [(16 d_{bar}), (48 d_{ties}), \text{Min} (D, b)]$$

$$s_{ties} = \text{Min} [(16 \times (0.625 \text{ in})), (48 \times (0.375 \text{ in})), \text{Min} ((48 \text{ in}), (48 \text{ in}))]$$

$$s_{ties} = 10 \text{ in}$$

#### Summary:

Main reinforcement: **14 - #5 (0.625 in)**

Ties: #3(0.375 in) - 10 in

**Axial Compression Strength (ACI 318-19, LRFD)**

22.4.2.2

$\phi P_N$  - Allowable axial compressive strength

$$\phi P_N = \phi 0.80 [(0.85 f'_{ck} [A_g - A_{st}]) + (f_{yk} A_{st})]$$

$$\phi P_N = (0.65) \times 0.80 \times [(0.85 \times (3 \text{ ksi}) \times [(2304 \text{ in}^2) - (4.2951 \text{ in}^2)]) + ((60 \text{ ksi}) \times (4.2951 \text{ in}^2))]$$

$$\phi P_N = 3183.4 \text{ kip}$$

Ratio - Capacity

$$\text{Ratio} = \frac{P}{\phi P_N}$$

$$\text{Ratio} = \frac{(6.211 \text{ kip})}{(3183.4 \text{ kip})}$$

$$\text{Ratio} = 0.001951$$

Status: **PASS**  
Ratio: **0.000**

**Shear Strength (ACI 318-19, LRFD)**

**Parameters:**

22.5.2.2

$b_w = 48 \text{ in}$  - Effective width,  
 $d$  - Effective depth

$$d = 0.80 D$$

$$d = 0.80 \times (48 \text{ in})$$

$$d = 38.4 \text{ in}$$

22.5.5.1.3

$\lambda_s$  - size effect modification factor

$$\lambda_s = \text{MIN} \left[ \sqrt{\frac{2}{1 + \frac{d}{10}}}, 1 \right]$$

$$\lambda_s = \text{MIN} \left[ \sqrt{\frac{2}{1 + \frac{(38.4 \text{ in})}{10}}}, 1 \right]$$

$$\lambda_s = 0.64282$$

22.5.5.1.1

The following variables were converted to be consistent with empirical formula  $f'_{ck} = 3 \text{ ksi} \rightarrow 3000 \text{ psi}$ ,  
 $V_{c,max}$  - Max shear strength of concrete

$$V_{c,max} = 5 \lambda_s \sqrt{f'_{ck}} b_w d$$

$$V_{c,max} = 5 \times (0.64282) \times \sqrt{(3000 \text{ psi})} \times (48 \text{ in}) \times (38.4 \text{ in})$$

$$V_{c,max} = 324.49 \text{ kip}$$

22.5.5.1.1(a)

The following variables were converted to be consistent with empirical formula  $f'_{ck} = 3 \text{ ksi} \rightarrow 3000 \text{ psi}$ ,  $P = 6.211 \text{ kip} \rightarrow 6211 \text{ lbf}$ ,  
 $V_{c,a}$  - Shear strength of concrete (a)

$$V_{c,a} = \left[ 2 \lambda_s \sqrt{f'_{ck}} + \frac{P}{6 A_g} \right] b_w d$$

$$V_{c,a} = \left[ 2 \times (0.64282) \times \sqrt{(3000 \text{ psi})} + \frac{(6211 \text{ lbf})}{6 \times (2304 \text{ in}^2)} \right] \times (48 \text{ in}) \times (38.4 \text{ in})$$

$$V_{c,a} = 130.62 \text{ kip}$$

22.5.5.1.2

The following variables were converted to be consistent with empirical formula  $f'_{ck} = 3 \text{ ksi} \rightarrow 3000 \text{ psi}$ ,  
 $V_{c,b}$  - Shear strength of concrete (b)

$$V_{c,b} = \left[ 2 \lambda_s \sqrt{f'_{ck}} + (0.05 f'_{ck}) \right] b_w d$$

$$V_{c,b} = \left[ 2 \times (0.64282) \times \sqrt{(3000 \text{ psi})} + (0.05 \times (3000 \text{ psi})) \right] \times (48 \text{ in}) \times (38.4 \text{ in})$$

$$V_{c,b} = 406.27 \text{ kip}$$

$V_c$  - Governing shear strength of concrete

$$V_c = \text{Min}[V_{c,max}, V_{c,a}, V_{c,b}]$$

$$V_c = \text{Min}[(324.49 \text{ kip}), (130.62 \text{ kip}), (406.27 \text{ kip})]$$

$$V_c = 130.62 \text{ kip}$$

<p>22.5.1.2</p>	<p>The following variables were converted to be consistent with empirical formula <math>f'_{ck} = 3 \text{ ksi} \rightarrow 3000 \text{ psi}</math>,  <math>V_{s,a}</math> - Shear strength of steel (a)</p> $V_{s,a} = 8 \sqrt{f'_{ck}} b_w d$ $V_{s,a} = 8 \times \sqrt{(3000 \text{ psi})} \times (48 \text{ in}) \times (38.4 \text{ in})$ $V_{s,a} = 807.65 \text{ kip}$ <p><math>A_v</math> - Ties rebar area,</p> $A_v = \frac{\pi d_{ties}^2}{4}$ $A_v = \frac{\pi \times (0.375 \text{ in})^2}{4}$ $A_v = 0.11045 \text{ in}^2$ <p>22.5.8.5.3 <math>V_{s,b}</math> - Shear strength of steel (b)</p> $V_{s,b} = \frac{2 A_v f_{yt} d}{s_{ties}}$ $V_{s,b} = \frac{2 \times (0.11045 \text{ in}^2) \times (60 \text{ ksi}) \times (38.4 \text{ in})}{(10 \text{ in})}$ $V_{s,b} = 50.894 \text{ kip}$ <p><math>V_s</math> - Governing shear strength of steel</p> $V_s = \text{MIN}[V_{s,a}, V_{s,b}]$ $V_s = \text{MIN}[(807.65 \text{ kip}), (50.894 \text{ kip})]$ $V_s = 50.894 \text{ kip}$ <p>22.5.1.1 <math>\phi V_n</math> - Allowable shear strength</p> $\phi V_n = \phi (V_c + V_s)$ $\phi V_n = (0.65) \times ((130.62 \text{ kip}) + (50.894 \text{ kip}))$ $\phi V_n = 117.99 \text{ kip}$ <p><b>Considering x-direction:</b></p> <p><math>V_{max} = 8.0794 \text{ kip}</math> - Maximum shear force in the x-direction,  Ratio - Capacity</p> $\text{Ratio} = \frac{V_{max}}{\phi V_n}$ $\text{Ratio} = \frac{(8.0794 \text{ kip})}{(117.99 \text{ kip})}$ $\text{Ratio} = 0.068478$ <p><b>Considering z-direction:</b></p> <p><math>V_{max} = 0.29751 \text{ kip}</math> - Maximum shear force in the z-direction,  Ratio - Capacity</p> $\text{Ratio} = \frac{V_{max}}{\phi V_n}$ $\text{Ratio} = \frac{(0.29751 \text{ kip})}{(117.99 \text{ kip})}$ $\text{Ratio} = 0.0025215$	<p>Status: <b>PASS</b>  Ratio: <b>0.070</b></p> <p>Status: <b>PASS</b>  Ratio: <b>0.000</b></p>
	<p><b>Flexural Strength (ACI 318-19, LRFD)</b></p> <p><math>S_m</math> - Section modulus</p> $S_m = \frac{b D^2}{6}$ $S_m = \frac{(48 \text{ in}) \times (48 \text{ in})^2}{6}$ $S_m = 18432 \text{ in}^3$	

<p>14.5.2.1b</p>	<p><math>\lambda = 1</math> - Concrete modification factor (Normal concrete),  Allowable flexural strength:  <math>M_n</math> shall be the lesser of:  <math>\phi M_{n,1}</math></p> $\phi M_{n,1} = \phi \times 5 \times \lambda \times \sqrt{f'_c} \times S_m$ $\phi M_{n,1} = 0.65 \times 5 \times 1 \times \sqrt{3 \text{ksi}} \times 18432.001 \text{in}^3$ $\phi M_{n,1} = 273.423 \text{kipft}$ <p><math>\phi M_{n,2}</math></p> $\phi M_{n,2} = \phi \times 0.85 \times f'_c \times S_m$ $\phi M_{n,2} = (0.65) \times 0.85 \times (3 \text{ksi}) \times (18432 \text{in}^3)$ $\phi M_{n,2} = 2545.9 \text{kipft}$ <p>Therefore,  <math>\phi M_n</math> - Allowable flexural strength,</p> $\phi M_n = \text{MIN}[\phi M_{n,1}, \phi M_{n,2}]$ $\phi M_n = \text{MIN}[(273.42 \text{kipft}), (2545.9 \text{kipft})]$ $\phi M_n = 273.42 \text{kipft}$ <p><b>Considering x-direction:</b>  <math>M_{max} = 22.102 \text{kipft}</math> - Maximum moment in the x-direction,  Ratio - Capacity</p> $\text{Ratio} = \frac{M_{max}}{\phi M_n}$ $\text{Ratio} = \frac{(22.102 \text{kipft})}{(273.42 \text{kipft})}$ $\text{Ratio} = 0.080833$	<p>Status: <b>PASS</b>  Ratio: <b>0.080</b></p>
	<p><b>Considering z-direction:</b>  <math>M_{max} = 0.75541 \text{kipft}</math> - Maximum moment in the z-direction,  Ratio - Capacity</p> $\text{Ratio} = \frac{M_{max}}{\phi M_n}$ $\text{Ratio} = \frac{(0.75541 \text{kipft})}{(273.42 \text{kipft})}$ $\text{Ratio} = 0.0027628$	<p>Status: <b>PASS</b>  Ratio: <b>0.000</b></p>

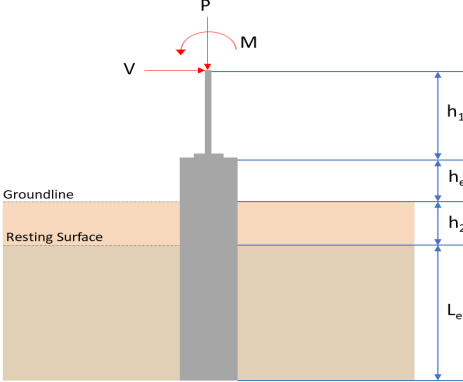
REFERENCES	CALCULATIONS	RESULTS																										
	<p><b>SkyCiv Foundation Design</b> Pile Foundation</p> <p><b>Design Information :</b> Design code : IBC 2021 (International Building Code) Unit System : Imperial</p>																											
	<p><b>Pile Input</b></p>  <p><b>Geometry</b> Pile shape: rectangular <math>b = 48</math> in - Pile width <math>D = 48</math> in - Pile depth <math>L = 5.75</math> ft - Total pile length <math>h_1 = 0</math> ft - Lateral load height from the top of the pile, <math>h_2 = 0</math> ft - Depth to resting surface <math>h_e = 0</math> ft - Length of pile above the ground</p> <p><b>Tabulation of Soil Parameters</b></p> <table border="1" data-bbox="416 1102 1193 1193"> <thead> <tr> <th>Layer</th> <th>Label</th> <th>Allowable Bearing Pressure (<math>q_a</math>) (psf)</th> <th>Allowable Lateral Pressure (<math>R</math>) (psf/ft)</th> </tr> </thead> <tbody> <tr> <td>1</td> <td>Sand, silty sand, clayey sand, silty gravel &amp; clayey gravel</td> <td>2000.000</td> <td>150.000</td> </tr> </tbody> </table> <p><b>Tabulation of Loads</b></p> <table border="1" data-bbox="676 1288 935 1458"> <thead> <tr> <th>Load Component</th> <th>ASD</th> <th>LRFD</th> </tr> </thead> <tbody> <tr> <td><math>P</math> (kip)</td> <td>3.986</td> <td>6.211</td> </tr> <tr> <td><math>V_x</math> (kip)</td> <td>-2.033</td> <td>-3.388</td> </tr> <tr> <td><math>V_z</math> (kip)</td> <td>-0.183</td> <td>-0.306</td> </tr> <tr> <td><math>M_x</math> (kipft)</td> <td>-0.514</td> <td>-0.855</td> </tr> <tr> <td><math>M_z</math> (kipft)</td> <td>20.118</td> <td>33.958</td> </tr> </tbody> </table> <p><b>Material Properties</b> <math>f'_{ck} = 3</math> ksi - Concrete strength,</p>	Layer	Label	Allowable Bearing Pressure ( $q_a$ ) (psf)	Allowable Lateral Pressure ( $R$ ) (psf/ft)	1	Sand, silty sand, clayey sand, silty gravel & clayey gravel	2000.000	150.000	Load Component	ASD	LRFD	$P$ (kip)	3.986	6.211	$V_x$ (kip)	-2.033	-3.388	$V_z$ (kip)	-0.183	-0.306	$M_x$ (kipft)	-0.514	-0.855	$M_z$ (kipft)	20.118	33.958	
Layer	Label	Allowable Bearing Pressure ( $q_a$ ) (psf)	Allowable Lateral Pressure ( $R$ ) (psf/ft)																									
1	Sand, silty sand, clayey sand, silty gravel & clayey gravel	2000.000	150.000																									
Load Component	ASD	LRFD																										
$P$ (kip)	3.986	6.211																										
$V_x$ (kip)	-2.033	-3.388																										
$V_z$ (kip)	-0.183	-0.306																										
$M_x$ (kipft)	-0.514	-0.855																										
$M_z$ (kipft)	20.118	33.958																										
	<p><b>Required depth to resist lateral loads (ASD)</b> <math>H</math> - Point of application of the lateral load</p> $H = h_1 + h_2 + h_e$ $H = (0 \text{ ft}) + (0 \text{ ft}) + (0 \text{ ft})$ $H = 0 \text{ ft}$ <p><b>Considering x-direction:</b> <math>H_o</math> - Lateral force per length of pile,</p> $H_o = \frac{V_x}{1.57 D}$ $H_o = \frac{(-2.033 \text{ kip})}{1.57 \times (48 \text{ in})}$ $H_o = -0.32373 \text{ kip/ft}$ <p><math>M_o</math> - Moment per length of pile,</p> $M_o = \frac{M_z + (V_x H)}{1.57 D}$																											

$$M_o = \frac{(20.118 \text{ kipft}) + ((-2.033 \text{ kip}) \times (0 \text{ ft}))}{1.57 \times (48 \text{ in})}$$

$$M_o = 3.2035 \text{ kipft/ft}$$

Required depth of embedment in earth:

$$L_x^3 - \left(14.14 \times \frac{H_o \times L_x}{R}\right) - \left(18.85 \times \frac{M_o}{R}\right) = 0$$

Solving the cubic equation:

$L_{e,x} = 5.3427 \text{ ft}$  - Required depth in x-direction,

**Considering z-direction:**

$H_o$  - Lateral force per length of pile,

$$H_o = \frac{V_z}{1.57 b}$$

$$H_o = \frac{(-0.183 \text{ kip})}{1.57 \times (48 \text{ in})}$$

$$H_o = -0.02914 \text{ kip/ft}$$

$M_o$  - Moment per length of pile,

$$M_o = \frac{M_x + (V_z H)}{1.57 b}$$

$$M_o = \frac{(0.514 \text{ kipft}) + ((-0.183 \text{ kip}) \times (0 \text{ ft}))}{1.57 \times (48 \text{ in})}$$

$$M_o = 0.081847 \text{ kipft/ft}$$

Required depth of embedment in earth:

$$L_z^3 - \left(14.14 \times \frac{H_o \times L_z}{R}\right) - \left(18.85 \times \frac{M_o}{R}\right) = 0$$

Solving the cubic equation:

$L_{e,z} = 1.5627 \text{ ft}$  - Required depth in z-direction,

**Minimum embedded depth required:**

$L_{e,req}$  - Depth of pile required,

$$L_{e,req} = \text{MAX}[L_{e,x}, L_{e,z}]$$

$$L_{e,req} = \text{MAX}[(5.3427 \text{ ft}), (1.5627 \text{ ft})]$$

$$L_{e,req} = 5.343 \text{ ft}$$

$L_e$  - Actual embedded length of pile,

$$L_e = L - h_e - h_2$$

$$L_e = (5.75 \text{ ft}) - (0 \text{ ft}) - (0 \text{ ft})$$

$$L_e = 5.75 \text{ ft}$$

**Ratio** - Embedded depth

$$\text{Ratio} = \frac{L_{e,req}}{L_e}$$

$$\text{Ratio} = \frac{(5.343 \text{ ft})}{(5.75 \text{ ft})}$$

$$\text{Ratio} = 0.92922$$

Status: **PASS**  
Ratio: **0.930**

**End-bearing Capacity (ASD)**

A - Pile cross-section area

$$A = b D$$

$$A = (48 \text{ in}) \times (48 \text{ in})$$

$$A = 16 \text{ ft}^2$$

q - End-bearing pressure

$$q = \frac{P_c}{A}$$

$$q = \frac{(3.986 \text{ kip})}{(16 \text{ ft}^2)}$$

$$q = 0.249125 \text{ kip/ft}^2$$

$$q = 0.24913 \text{ kip/ft}^2$$

**Check bearing capacity ratio:**

Ratio - Capacity

$$\text{Ratio} = \frac{q}{q_a}$$

$$\text{Ratio} = \frac{(0.24913 \text{ kip/ft}^2)}{(2000 \text{ psf})}$$

$$\text{Ratio} = 0.12456$$

Status: **PASS**  
Ratio: **0.120**

Czerniak

**Lateral Soil Pressure (ASD):**

$L/D$  - Length to least lateral dimension ratio,

$$L/D = \frac{L}{D}$$

$$L/D = \frac{(5.75 \text{ ft})}{(48 \text{ in})}$$

$$L/D = 1.4375$$

Since  $L/D \leq 10$ ,

Pile is short.

**Considering x-direction:**

$H_o = -0.32373 \text{ kip/ft}$  - Lateral force per length of pile,

$M_o = 3.2035 \text{ kipft/ft}$  - Overturning moment per length of pile,

$a$  - Distance from resting surface to pivot point,

$$a = \frac{(4 M_o L_e) + (3 H_o L_e^2)}{(6 M_o) + (4 H_o L_e)}$$

$$a = \frac{(4 \times (3.2035 \text{ kipft/ft}) \times (5.75 \text{ ft})) + (3 \times (-0.32373 \text{ kip/ft}) \times (5.75 \text{ ft})^2)}{(6 \times (3.2035 \text{ kipft/ft})) + (4 \times (-0.32373 \text{ kip/ft}) \times (5.75 \text{ ft}))}$$

$$a = 3.9671 \text{ ft}$$

$p$  - Earth pressure against the pile at distance  $a/2$  from resting surface,

$$p = \frac{0.75 [(4 M_o) + (3 H_o L_e)]^2}{L_e^2 [(3 M_o) + (2 H_o L_e)]}$$

$$p = \frac{0.75 \times [(4 \times (3.2035 \text{ kipft/ft})) + (3 \times (-0.32373 \text{ kip/ft}) \times (5.75 \text{ ft}))]^2}{(5.75 \text{ ft})^2 \times [(3 \times (3.2035 \text{ kipft/ft})) + (2 \times (-0.32373 \text{ kip/ft}) \times (5.75 \text{ ft}))]}$$

$$p = 0.20139 \text{ kip/ft}^2$$

$s$  - Earth pressure against the pile at distance  $L_e$ ,

$$s = \frac{6 [(2 M_o) + (H_o L_e)]}{L_e^2}$$

$$s = \frac{6 \times [(2 \times (3.2035 \text{ kipft/ft})) + ((-0.32373 \text{ kip/ft}) \times (5.75 \text{ ft}))]}{(5.75 \text{ ft})^2}$$

$$s = 0.82491 \text{ kip/ft}^2$$

**Check lateral soil pressure capacity:**

$p_a$  - Allowable lateral soil pressure at depth  $a/2$ ,

$$p_a = R \frac{a}{2}$$

$$p_a = (150 \text{ psf/ft}) \times \frac{(3.9671 \text{ ft})}{2}$$

$$p_a = 0.29753 \text{ kip/ft}^2$$

Ratio - Lateral soil capacity

$$\text{Ratio} = \frac{p}{p_a}$$

$$\text{Ratio} = \frac{(0.20139 \text{ kip/ft}^2)}{(0.29753 \text{ kip/ft}^2)}$$

$$\text{Ratio} = 0.67685$$

$p_a$  - Allowable lateral soil pressure at depth  $L_e$ ,

Status: **PASS**  
Ratio: **0.680**

	$p_s = R L_e$ $p_s = (150 \text{ psf/ft}) \times (5.75 \text{ ft})$ $p_s = 0.8625 \text{ kip/ft}^2$ <p>Ratio - Lateral soil capacity</p> $\text{Ratio} = \frac{s}{p_s}$ $\text{Ratio} = \frac{(0.82491 \text{ kip/ft}^2)}{(0.8625 \text{ kip/ft}^2)}$ $\text{Ratio} = 0.95641$	<p>Status: <b>PASS</b> Ratio: <b>0.960</b></p>
	<p><b>Considering z-direction:</b></p> <p><math>H_o = -0.02914 \text{ kip/ft}</math> - Lateral force per length of pile,  <math>M_o = 0.081847 \text{ kipft/ft}</math> - Overturning moment per length of pile,  <math>a</math> - Distance from resting surface to pivot point,</p> $a = \frac{(4 M_o L_e) + (3 H_o L_e^2)}{(6 M_o) + (4 H_o L_e)}$ $a = \frac{(4 \times (0.081847 \text{ kipft/ft}) \times (5.75 \text{ ft})) + (3 \times (-0.02914 \text{ kip/ft}) \times (5.75 \text{ ft})^2)}{(6 \times (0.081847 \text{ kipft/ft})) + (4 \times (-0.02914 \text{ kip/ft}) \times (5.75 \text{ ft}))}$ $a = 4.1099 \text{ ft}$ <p><math>p</math> - Earth pressure against the pile at distance <math>a/2</math> from resting surface,</p> $p = \frac{0.75 [(4 M_o) + (3 H_o L_e)]^2}{L_e^2 [(3 M_o) + (2 H_o L_e)]}$ $p = \frac{0.75 [(4 \times (0.081847 \text{ kipft/ft})) + (3 \times (-0.02914 \text{ kip/ft}) \times (5.75 \text{ ft}))]^2}{(5.75 \text{ ft})^2 [(3 \times (0.081847 \text{ kipft/ft})) + (2 \times (-0.02914 \text{ kip/ft}) \times (5.75 \text{ ft}))]}$ $p = -0.0077807 \text{ kip/ft}^2$ <p><math>s</math> - Earth pressure against the pile at distance <math>L_e</math>,</p> $s = \frac{6 [(2 M_o) + (H_o L_e)]}{L_e^2}$ $s = \frac{6 [(2 \times (0.081847 \text{ kipft/ft})) + ((-0.02914 \text{ kip/ft}) \times (5.75 \text{ ft}))]}{(5.75 \text{ ft})^2}$ $s = -0.00070076 \text{ kip/ft}^2$ <p><b>Check lateral soil pressure capacity:</b></p> <p><math>p_a</math> - Allowable lateral soil pressure at depth <math>a/2</math>,</p> $p_a = R \frac{a}{2}$ $p_a = (150 \text{ psf/ft}) \times \frac{(4.1099 \text{ ft})}{2}$ $p_a = 0.30824 \text{ kip/ft}^2$ <p>Ratio - Lateral soil capacity</p> $\text{Ratio} = \frac{p}{p_a}$ $\text{Ratio} = \frac{(-0.0077807 \text{ kip/ft}^2)}{(0.30824 \text{ kip/ft}^2)}$ $\text{Ratio} = -0.025242$ <p><math>p_s</math> - Allowable lateral soil pressure at depth <math>L_e</math>,</p> $p_s = R L_e$ $p_s = (150 \text{ psf/ft}) \times (5.75 \text{ ft})$ $p_s = 0.8625 \text{ kip/ft}^2$ <p>Ratio - Lateral soil capacity</p> $\text{Ratio} = \frac{s}{p_s}$	<p>Status: <b>PASS</b> Ratio: <b>-0.030</b></p>

$$\text{Ratio} = \frac{(-0.00070076 \text{ kip/ft}^2)}{(0.8625 \text{ kip/ft}^2)}$$

$$\text{Ratio} = -0.00081247$$

Status: **PASS**  
Ratio: **0.000**

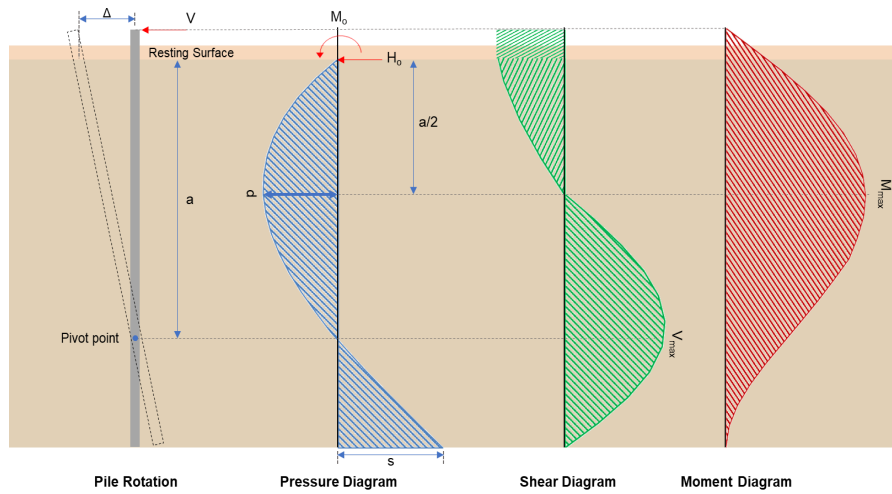

#### Shear force and Bending moment (x-direction, LRFD)

$H_o$  - Lateral force per length of pile,

$$H_o = \frac{V_e}{1.57 D}$$

$$H_o = \frac{(-3.388 \text{ kip})}{1.57 \times (48 \text{ in})}$$

$$H_o = -0.53949 \text{ kip/ft}$$

$M_o$  - Moment per length of pile,

$$M_o = \frac{M_z + (V_x H)}{1.57 D}$$

$$M_o = \frac{(33.958 \text{ kipft}) + ((-3.388 \text{ kip}) \times (0 \text{ ft}))}{1.57 \times (48 \text{ in})}$$

$$M_o = 5.4073 \text{ kipft/ft}$$

$E$  - Distance from lateral load to resisting surface,

$$E = \frac{M_o}{H_o}$$

$$E = \frac{(5.4073 \text{ kipft/ft})}{(-0.53949 \text{ kip/ft})}$$

$$E = 10.023 \text{ ft}$$

$a$  - Distance from resting surface to pivot point,

$$a = \frac{(4 M_o L_e) + (3 H_o L_e^2)}{(6 M_o) + (4 H_o L_e)}$$

$$a = \frac{(4 \times (5.4073 \text{ kipft/ft}) \times (5.75 \text{ ft})) + (3 \times (-0.53949 \text{ kip/ft}) \times (5.75 \text{ ft})^2)}{(6 \times (5.4073 \text{ kipft/ft})) + (4 \times (-0.53949 \text{ kip/ft}) \times (5.75 \text{ ft}))}$$

$$a = 3.9659 \text{ ft}$$

$V_{max}$  - Max shear force located at depth  $a$ ,

$$V_{max} = (H_o D) \left[ 1 - \left[ 3 \left( \frac{4 E}{L_e} + 3 \right) \left( \frac{a}{L_e} \right)^2 \right] + \left[ 4 \left( \frac{3 E}{L_e} + 2 \right) \left( \frac{a}{L_e} \right)^3 \right] \right]$$

$$V_{max} = ((-0.53949 \text{ kip/ft}) \times (48 \text{ in})) \times \left[ 1 - \left[ 3 \times \left( \frac{4 \times (10.023 \text{ ft})}{(5.75 \text{ ft})} + 3 \right) \times \left( \frac{(3.9659 \text{ ft})}{(5.75 \text{ ft})} \right)^2 \right] + \left[ 4 \times \left( \frac{3 \times (10.023 \text{ ft})}{(5.75 \text{ ft})} + 2 \right) \times \left( \frac{(3.9659 \text{ ft})}{(5.75 \text{ ft})} \right)^3 \right] \right]$$

$$V_{max} = 8.0796 \text{ kip}$$

$M_{max}$  - Max bending moment located at depth  $a/2$ ,

$$M_{max} = (H_o D L_e) \left[ \left( \frac{E}{L_e} + \frac{a}{2 L_e} \right) - \left[ \left( \frac{4 E}{L_e} + 3 \right) \left( \frac{a}{2 L_e} \right)^3 \right] + \left[ \left( \frac{3 E}{L_e} + 2 \right) \left( \frac{a}{2 L_e} \right)^4 \right] \right]$$

$$M_{max} = ((-0.53949 \text{ kip/ft}) \times (48 \text{ in}) \times (5.75 \text{ ft})) \times \left[ \left( \frac{(10.023 \text{ ft})}{(5.75 \text{ ft})} + \frac{(3.9659 \text{ ft})}{2 \times (5.75 \text{ ft})} \right) - \left[ \left( \frac{4 \times (10.023 \text{ ft})}{(5.75 \text{ ft})} + 3 \right) \times \left( \frac{(3.9659 \text{ ft})}{2 \times (5.75 \text{ ft})} \right)^3 \right] + \left[ \left( \frac{3 \times (10.023 \text{ ft})}{(5.75 \text{ ft})} + 2 \right) \times \left( \frac{(3.9659 \text{ ft})}{2 \times (5.75 \text{ ft})} \right)^4 \right] \right]$$

$$M_{max} = 22.102 \text{ kipft}$$

### Shear force and Bending moment (z-direction, LRFD)

$H_o$  - Lateral force per length of pile,

$$H_o = \frac{V_z}{1.57 b}$$

$$H_o = \frac{(-0.306 \text{ kip})}{1.57 \times (48 \text{ in})}$$

$$H_o = -0.048726 \text{ kip/ft}$$

$M_o$  - Moment per length of pile,

$$M_o = \frac{M_x + (V_z H)}{1.57 b}$$

$$M_o = \frac{(0.855 \text{ kipft}) + ((-0.306 \text{ kip}) \times (0 \text{ ft}))}{1.57 \times (48 \text{ in})}$$

$$M_o = 0.13615 \text{ kipft/ft}$$

$E$  - Distance from lateral load to resisting surface,

$$E = \frac{M_o}{H_o}$$

$$E = \frac{(0.13615 \text{ kipft/ft})}{(-0.048726 \text{ kip/ft})}$$

$$E = 2.7941 \text{ ft}$$

$a$  - Distance from resting surface to pivot point,

$$a = \frac{(4 M_o L_e) + (3 H_o L_e^2)}{(6 M_o) + (4 H_o L_e)}$$

$$a = \frac{(4 \times (0.13615 \text{ kipft/ft}) \times (5.75 \text{ ft})) + (3 \times (-0.048726 \text{ kip/ft}) \times (5.75 \text{ ft})^2)}{(6 \times (0.13615 \text{ kipft/ft})) + (4 \times (-0.048726 \text{ kip/ft}) \times (5.75 \text{ ft}))}$$

$$a = 4.1105 \text{ ft}$$

$V_{max}$  - Max shear force located at depth  $a$ ,

$$V_{max} = (H_o b) \left[ 1 - \left[ 3 \left( \frac{4 E}{L_e} + 3 \right) \left( \frac{a}{L_e} \right)^2 \right] + \left[ 4 \left( \frac{3 E}{L_e} + 2 \right) \left( \frac{a}{L_e} \right)^3 \right] \right]$$

$$V_{max} = ((-0.048726 \text{ kip/ft}) \times (48 \text{ in})) \times \left[ 1 - \left[ 3 \times \left( \frac{4 \times (2.7941 \text{ ft})}{(5.75 \text{ ft})} + 3 \right) \times \left( \frac{(4.1105 \text{ ft})}{(5.75 \text{ ft})} \right)^2 \right] + \left[ 4 \times \left( \frac{3 \times (2.7941 \text{ ft})}{(5.75 \text{ ft})} + 2 \right) \times \left( \frac{(4.1105 \text{ ft})}{(5.75 \text{ ft})} \right)^3 \right] \right]$$

$$V_{max} = 0.29751 \text{ kip}$$

$M_{max}$  - Max bending moment located at depth  $a/2$ ,

$$M_{max} = (H_o b L_e) \left[ \left( \frac{E}{L_e} + \frac{a}{2 L_e} \right) - \left[ \left( \frac{4 E}{L_e} + 3 \right) \left( \frac{a}{2 L_e} \right)^3 \right] + \left[ \left( \frac{3 E}{L_e} + 2 \right) \left( \frac{a}{2 L_e} \right)^4 \right] \right]$$

$$M_{max} = ((-0.048726 \text{ kip/ft}) \times (48 \text{ in}) \times (5.75 \text{ ft})) \times \left[ \left( \frac{(2.7941 \text{ ft})}{(5.75 \text{ ft})} + \frac{(4.1105 \text{ ft})}{2 \times (5.75 \text{ ft})} \right) - \left[ \left( \frac{4 \times (2.7941 \text{ ft})}{(5.75 \text{ ft})} + 3 \right) \times \left( \frac{(4.1105 \text{ ft})}{2 \times (5.75 \text{ ft})} \right)^3 \right] + \left[ \left( \frac{3 \times (2.7941 \text{ ft})}{(5.75 \text{ ft})} + 2 \right) \times \left( \frac{(4.1105 \text{ ft})}{2 \times (5.75 \text{ ft})} \right)^4 \right] \right]$$

$$M_{max} = 0.75541 \text{ kipft}$$

### Minimum Reinforcement Check (LRFD)

#### Parameters:

$f'_{ck} = 3 \text{ ksi}$  - Concrete strength,  
 $f_{yk} = 60 \text{ ksi}$  - Longitudinal reinforcement strength,  
 $\phi = 0.65$  - Reduction factor for axial strength,  
 $\alpha = 0.8$  - Alpha factor for axial strength,  
 $A_g = 2304 \text{ in}^2$  - Gross area of concrete,

Table 22.4.2.1

#### Longitudinal reinforcement:

Required reinforcement due to axial load,  $A_{st,required}$

22.4.2.2, 10.6.1.1

$A_{st,required}$

$$A_{st,required} = \text{Min} \left[ \frac{\frac{P}{\phi \alpha} - (0.85 f'_{ck} A_g)}{f_{yk} - (0.85 f'_{ck})}, (0.08 A_g) \right]$$

$$A_{st,required} = \text{Min} \left[ \frac{\frac{(6.211 \text{ kip})}{(0.65) \times (0.8)} - (0.85 \times (3 \text{ ksi}) \times (2304 \text{ in}^2))}{(60 \text{ ksi}) - (0.85 \times (3 \text{ ksi}))}, (0.08 \times (2304 \text{ in}^2)) \right]$$

$$A_{st,required} = -102.06 \text{ in}^2$$

$A_{min}$  - Governing minimum reinforcement area,

$$A_{min} = \text{Max} [A_{st,required}, (0.0018 A_g)]$$

$$A_{min} = \text{Max} [(-102.06 \text{ in}^2), (0.0018 \times (2304 \text{ in}^2))]$$

$$A_{min} = 4.1472 \text{ in}^2$$

$n_{rebar}$  - Required number of reinforcement,

$$n_{rebar} = \frac{A_{min}}{A_{rebar}}$$

$$n_{rebar} = \frac{(4.1472 \text{ in}^2)}{(0.3068 \text{ in}^2)}$$

$$n_{rebar} = 14$$

$A_{st}$  - Actual total reinforcement area,

$$A_{st} = n_{rebar} \frac{\pi d_{bar}^2}{4}$$

$$A_{st} = (14) \times \frac{\pi \times (0.625 \text{ in})^2}{4}$$

$$A_{st} = 4.2951 \text{ in}^2$$

Ratio - Capacity

$$\text{Ratio} = \frac{A_{min}}{A_{st}}$$

$$\text{Ratio} = \frac{(4.1472 \text{ in}^2)}{(4.2951 \text{ in}^2)}$$

$$\text{Ratio} = 0.96556$$

25.2.3

$s_{rebar}$  - Minimum spacing of reinforcement,

$$s_{rebar} = \text{Max} [1.5, (1.5 d_{bar})]$$

$$s_{rebar} = \text{Max} [1.5, (1.5 \times (0.625 \text{ in}))]$$

$$s_{rebar} = 1.5 \text{ in}$$

#### Ties:

25.7.2.2 Since longitudinal reinforcement is  $\leq$  No. 10: Use #3(0.375 in)

25.7.2.1  $s_{ties}$  - Maximum spacing of ties,

$$s_{ties} = \text{Min} [(16 d_{bar}), (48 d_{ties}), \text{Min} (D, b)]$$

$$s_{ties} = \text{Min} [(16 \times (0.625 \text{ in})), (48 \times (0.375 \text{ in})), \text{Min} ((48 \text{ in}), (48 \text{ in}))]$$

$$s_{ties} = 10 \text{ in}$$

#### Summary:

Main reinforcement: 14 - #5 (0.625 in)

Status: **PASS**  
Ratio: **0.970**

Ties: #3(0.375 in) - 10 in

**Axial Compression Strength (ACI 318-19, LRFD)**

22.4.2.2

$\phi P_N$  - Allowable axial compressive strength

$$\phi P_N = \phi 0.80 [(0.85 f'_{ck} [A_g - A_{st}]) + (f_{yk} A_{st})]$$

$$\phi P_N = (0.65) \times 0.80 \times [(0.85 \times (3 \text{ ksi}) \times [(2304 \text{ in}^2) - (4.2951 \text{ in}^2)]) + ((60 \text{ ksi}) \times (4.2951 \text{ in}^2))]$$

$$\phi P_N = 3183.4 \text{ kip}$$

Ratio - Capacity

$$\text{Ratio} = \frac{P}{\phi P_N}$$

$$\text{Ratio} = \frac{(6.211 \text{ kip})}{(3183.4 \text{ kip})}$$

$$\text{Ratio} = 0.001951$$

Status: **PASS**  
Ratio: **0.000**

**Shear Strength (ACI 318-19, LRFD)**

**Parameters:**

22.5.2.2

$b_w = 48 \text{ in}$  - Effective width,  
 $d$  - Effective depth

$$d = 0.80 D$$

$$d = 0.80 \times (48 \text{ in})$$

$$d = 38.4 \text{ in}$$

22.5.5.1.3

$\lambda_s$  - size effect modification factor

$$\lambda_s = \text{MIN} \left[ \sqrt{\frac{2}{1 + \frac{d}{10}}}, 1 \right]$$

$$\lambda_s = \text{MIN} \left[ \sqrt{\frac{2}{1 + \frac{(38.4 \text{ in})}{10}}}, 1 \right]$$

$$\lambda_s = 0.64282$$

22.5.5.1.1

The following variables were converted to be consistent with empirical formula  $f'_{ck} = 3 \text{ ksi} \rightarrow 3000 \text{ psi}$ ,  
 $V_{c,max}$  - Max shear strength of concrete

$$V_{c,max} = 5 \lambda_s \sqrt{f'_{ck}} b_w d$$

$$V_{c,max} = 5 \times (0.64282) \times \sqrt{(3000 \text{ psi})} \times (48 \text{ in}) \times (38.4 \text{ in})$$

$$V_{c,max} = 324.49 \text{ kip}$$

22.5.5.1.1(a)

The following variables were converted to be consistent with empirical formula  $f'_{ck} = 3 \text{ ksi} \rightarrow 3000 \text{ psi}$ ,  $P = 6.211 \text{ kip} \rightarrow 6211 \text{ lbf}$ ,  
 $V_{c,a}$  - Shear strength of concrete (a)

$$V_{c,a} = \left[ 2 \lambda_s \sqrt{f'_{ck}} + \frac{P}{6 A_g} \right] b_w d$$

$$V_{c,a} = \left[ 2 \times (0.64282) \times \sqrt{(3000 \text{ psi})} + \frac{(6211 \text{ lbf})}{6 \times (2304 \text{ in}^2)} \right] \times (48 \text{ in}) \times (38.4 \text{ in})$$

$$V_{c,a} = 130.62 \text{ kip}$$

22.5.5.1.2

The following variables were converted to be consistent with empirical formula  $f'_{ck} = 3 \text{ ksi} \rightarrow 3000 \text{ psi}$ ,  
 $V_{c,b}$  - Shear strength of concrete (b)

$$V_{c,b} = \left[ 2 \lambda_s \sqrt{f'_{ck}} + (0.05 f'_{ck}) \right] b_w d$$

$$V_{c,b} = \left[ 2 \times (0.64282) \times \sqrt{(3000 \text{ psi})} + (0.05 \times (3000 \text{ psi})) \right] \times (48 \text{ in}) \times (38.4 \text{ in})$$

$$V_{c,b} = 406.27 \text{ kip}$$

$V_c$  - Governing shear strength of concrete

$$V_c = \text{Min}[V_{c,max}, V_{c,a}, V_{c,b}]$$

$$V_c = \text{Min}[(324.49 \text{ kip}), (130.62 \text{ kip}), (406.27 \text{ kip})]$$

$$V_c = 130.62 \text{ kip}$$

<p>22.5.1.2</p>	<p>The following variables were converted to be consistent with empirical formula <math>f'_{ck} = 3 \text{ ksi} \rightarrow 3000 \text{ psi}</math>,  <math>V_{s,a}</math> - Shear strength of steel (a)</p> $V_{s,a} = 8 \sqrt{f'_{ck}} b_w d$ $V_{s,a} = 8 \times \sqrt{(3000 \text{ psi})} \times (48 \text{ in}) \times (38.4 \text{ in})$ $V_{s,a} = 807.65 \text{ kip}$ <p><math>A_v</math> - Ties rebar area,</p> $A_v = \frac{\pi d_{ties}^2}{4}$ $A_v = \frac{\pi \times (0.375 \text{ in})^2}{4}$ $A_v = 0.11045 \text{ in}^2$ <p>22.5.8.5.3 <math>V_{s,b}</math> - Shear strength of steel (b)</p> $V_{s,b} = \frac{2 A_v f_{yt} d}{s_{ties}}$ $V_{s,b} = \frac{2 \times (0.11045 \text{ in}^2) \times (60 \text{ ksi}) \times (38.4 \text{ in})}{(10 \text{ in})}$ $V_{s,b} = 50.894 \text{ kip}$ <p><math>V_s</math> - Governing shear strength of steel</p> $V_s = \text{MIN}[V_{s,a}, V_{s,b}]$ $V_s = \text{MIN}[(807.65 \text{ kip}), (50.894 \text{ kip})]$ $V_s = 50.894 \text{ kip}$ <p>22.5.1.1 <math>\phi V_n</math> - Allowable shear strength</p> $\phi V_n = \phi (V_c + V_s)$ $\phi V_n = (0.65) \times ((130.62 \text{ kip}) + (50.894 \text{ kip}))$ $\phi V_n = 117.99 \text{ kip}$ <p><b>Considering x-direction:</b></p> <p><math>V_{max} = 8.0796 \text{ kip}</math> - Maximum shear force in the x-direction,  Ratio - Capacity</p> $\text{Ratio} = \frac{V_{max}}{\phi V_n}$ $\text{Ratio} = \frac{(8.0796 \text{ kip})}{(117.99 \text{ kip})}$ $\text{Ratio} = 0.068479$ <p><b>Considering z-direction:</b></p> <p><math>V_{max} = 0.29751 \text{ kip}</math> - Maximum shear force in the z-direction,  Ratio - Capacity</p> $\text{Ratio} = \frac{V_{max}}{\phi V_n}$ $\text{Ratio} = \frac{(0.29751 \text{ kip})}{(117.99 \text{ kip})}$ $\text{Ratio} = 0.0025215$	<p>Status: <b>PASS</b>  Ratio: <b>0.070</b></p> <p>Status: <b>PASS</b>  Ratio: <b>0.000</b></p>
	<p><b>Flexural Strength (ACI 318-19, LRFD)</b></p> <p><math>S_m</math> - Section modulus</p> $S_m = \frac{b D^2}{6}$ $S_m = \frac{(48 \text{ in}) \times (48 \text{ in})^2}{6}$ $S_m = 18432 \text{ in}^3$	

<p>14.5.2.1b</p>	<p><math>\lambda = 1</math> - Concrete modification factor (Normal concrete),  Allowable flexural strength:  <math>M_n</math> shall be the lesser of:  <math>\phi M_{n,1}</math></p> $\phi M_{n,1} = \phi \times 5 \times \lambda \times \sqrt{f'_c} \times S_m$ $\phi M_{n,1} = 0.65 \times 5 \times 1 \times \sqrt{3\text{ksi}} \times 18432.001\text{in}^3$ $\phi M_{n,1} = 273.423\text{kipft}$ <p><math>\phi M_{n,2}</math></p> $\phi M_{n,2} = \phi \times 0.85 \times f'_c \times S_m$ $\phi M_{n,2} = (0.65) \times 0.85 \times (3\text{ksi}) \times (18432\text{in}^3)$ $\phi M_{n,2} = 2545.9\text{kipft}$ <p>Therefore,  <math>\phi M_n</math> - Allowable flexural strength,</p> $\phi M_n = \text{MIN}[\phi M_{n,1}, \phi M_{n,2}]$ $\phi M_n = \text{MIN}[(273.42\text{kipft}), (2545.9\text{kipft})]$ $\phi M_n = 273.42\text{kipft}$ <p><b>Considering x-direction:</b>  <math>M_{max} = 22.102\text{kipft}</math> - Maximum moment in the x-direction,  Ratio - Capacity</p> $\text{Ratio} = \frac{M_{max}}{\phi M_n}$ $\text{Ratio} = \frac{(22.102\text{kipft})}{(273.42\text{kipft})}$ $\text{Ratio} = 0.080835$	<p>Status: <b>PASS</b>  Ratio: <b>0.080</b></p>
	<p><b>Considering z-direction:</b>  <math>M_{max} = 0.75541\text{kipft}</math> - Maximum moment in the z-direction,  Ratio - Capacity</p> $\text{Ratio} = \frac{M_{max}}{\phi M_n}$ $\text{Ratio} = \frac{(0.75541\text{kipft})}{(273.42\text{kipft})}$ $\text{Ratio} = 0.0027628$	<p>Status: <b>PASS</b>  Ratio: <b>0.000</b></p>