

Your Project Calculations



Project Name: JB-RevB

S3D Model Link:

https://platform.skyciv.com/structural?preload_name=JB-RevB&preload_path=Shared%20Enterprise%20Folder/MT_Solar_Projects/3_2023

Public Model Link:

https://platform.skyciv.com/structural-viewer?project_id=asosIPZBGpxBY70jKnZkHcwoughJqM8PCkel6dNRiO73mdWyBeS6Eq4Irh6lhyk2

Array Specification

Product:	Beam
Unique ID:	2P-15-6TOP-SD-24-L-5Hx4W-1L8D
Duty Classification:	SD
Module Width:	41.30 in
Module Length:	83.90in
Number of Rows:	5
Number of Columns:	4
Total Number of Modules:	20
Desired Tilt Angle:	15
Front Edge Clearance:	7
Total Array Height at Tilt:	11.48 ft
Total Frame Length:	26.50 ft
Frame Weight:	1131 lbs
Array Dimensions N/S:	17.42 ft
Array Dimensions E/W:	28.30 ft
Rail Length:	209.00 in
Rail Spacing:	3.50 ft
Rail Check:	Not Checked

Support Specifications

Pole Size:	6in Pipe Sch 40
Pole Length above Grade:	9.25 ft
Number of Poles:	2
Pole Spacing:	15 ft

Foundation Specifications

Foundation Type:	Square
Foundation Dimensions:	48 x 48 in
Foundation Depth (below grade):	Pile 1: 5.00 ft Pile 2: 5.00 ft
Foundation Volume:	5.926 y ³
Foundation Result:	PASSED

Site Info

Risk Category:	I
Exposure:	C
Soil Classification:	sand
Site Location:	54179 Herak Rd, Charlo, MT 59824, USA
Wind Speed:	99 mph
Snow Load:	20 psf
Design Uplift Pressure:	Multiple pressures
Design Downforce Pressure:	Multiple pressures
Design Snow Pressure:	0.011684 ksf

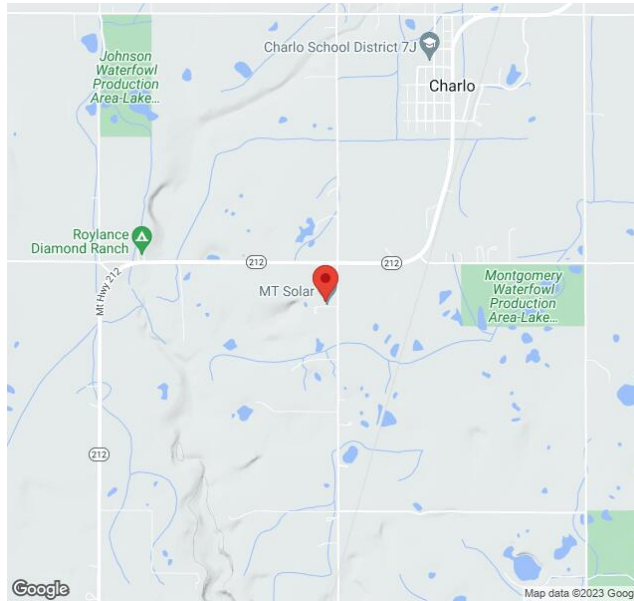

Design Disclaimer

This software should be used for preliminary designs and should not be used as a final design unless reviewed, verified and designed by a qualified structural engineer.

AutoDesigner Input

```
{
  "wind_speed_override": null,
  "snow_load_override": null,
  "direct_snow_load": false,
  "product_type": "Beam",
  "project_id": "JB-RevB",
  "site_address": "54179 Herak Rd, Charlo, MT 59824, USA",
  "module_width": 41.3,
  "module_length": 83.9,
  "number_rows": 5,
  "number_columns": 4,
  "pole_mount_section": "4_40",
  "core_pipe_width": 65,
  "core_pipe_section": "2_40",
  "adjuster_section": "2_40",
  "core_beam_height": 65,
  "core_beam_section": "HSS3x2x1/8",
  "main_pipe_section": "2_12GA",
  "pole_spacing": 15,
  "tilt_angle": 15,
  "ground_clearance": 7,
  "risk_category": "I",
  "exposure_category": "C",
  "frame_duty_override": "auto",
  "pole_override": "auto",
  "soil_type": "sand",
  "foundation_type": "Square",
  "foundation_size": 48,
  "check_rails": false
}
```

Design Notes:

- AISC Deflection checks are set to L/1 due to structure design intent
- Foundation Design and Sizing is approximate only

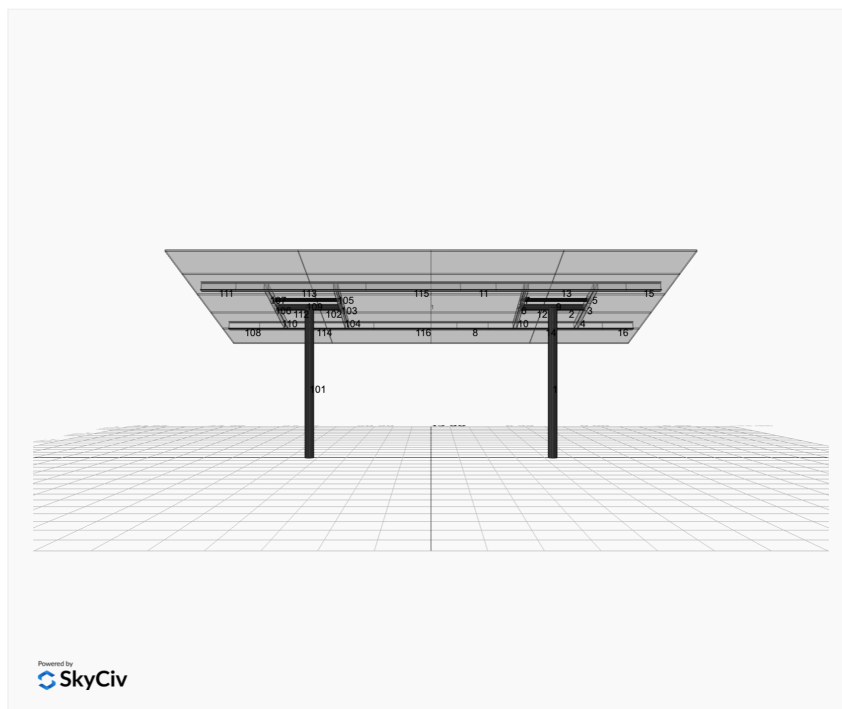

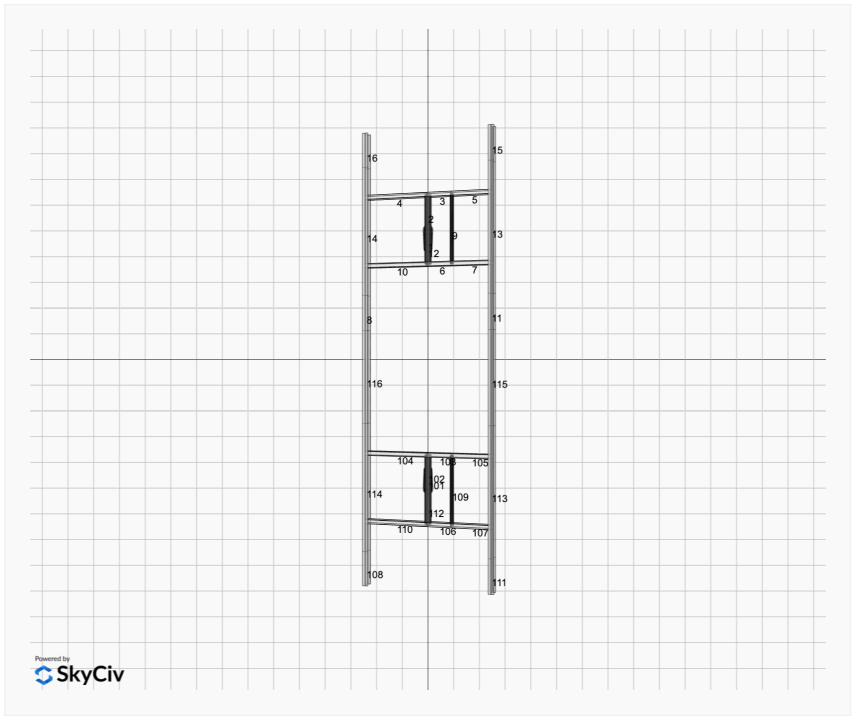
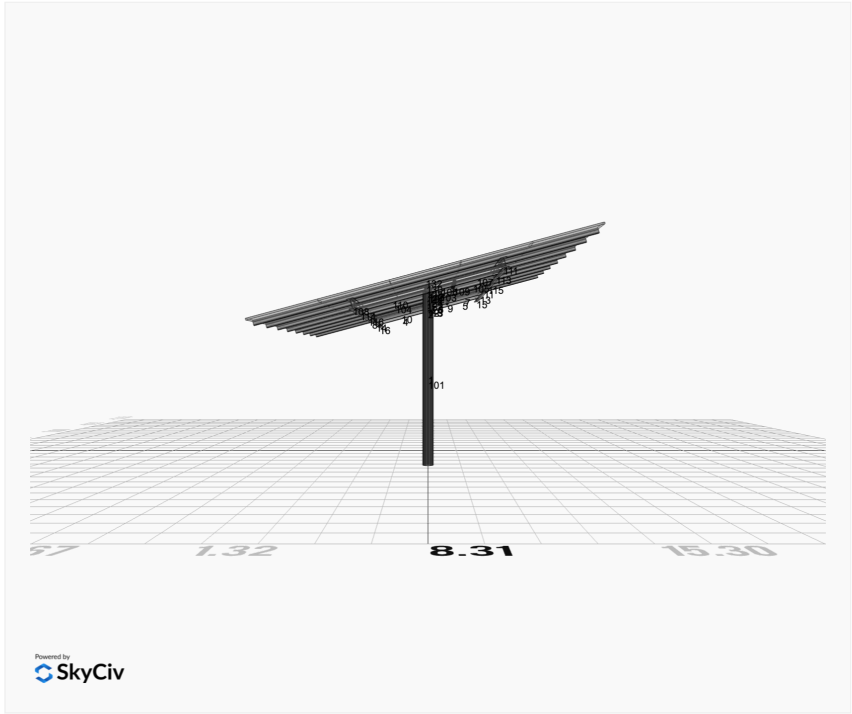

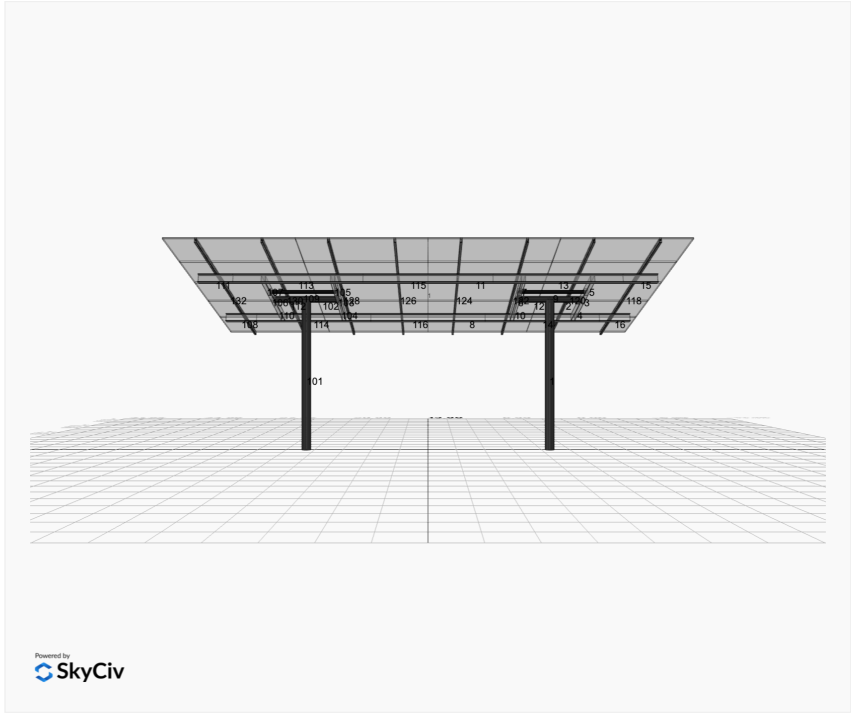
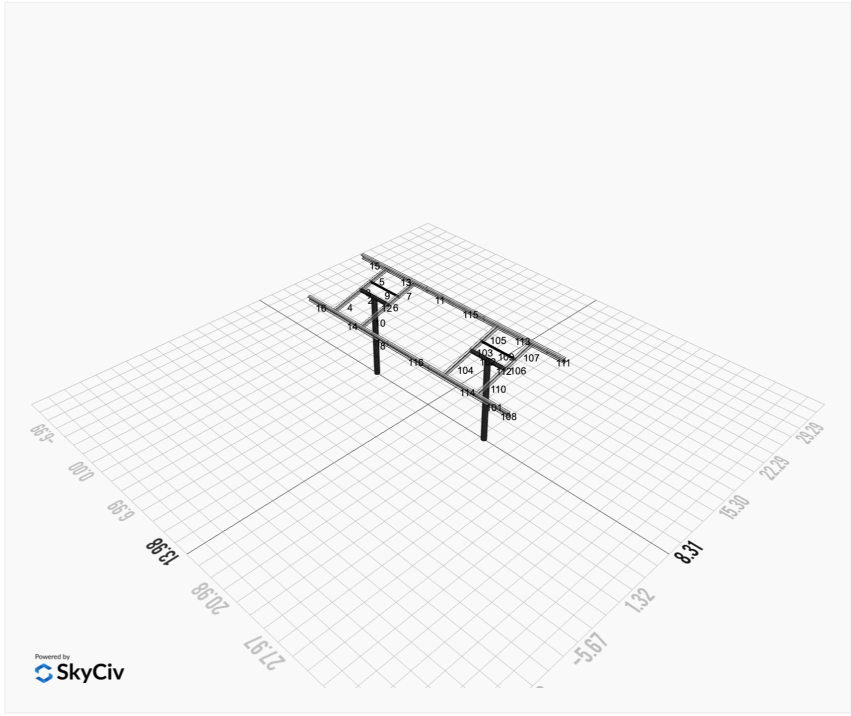

FEM Results (Envelope Worst Case for each member)

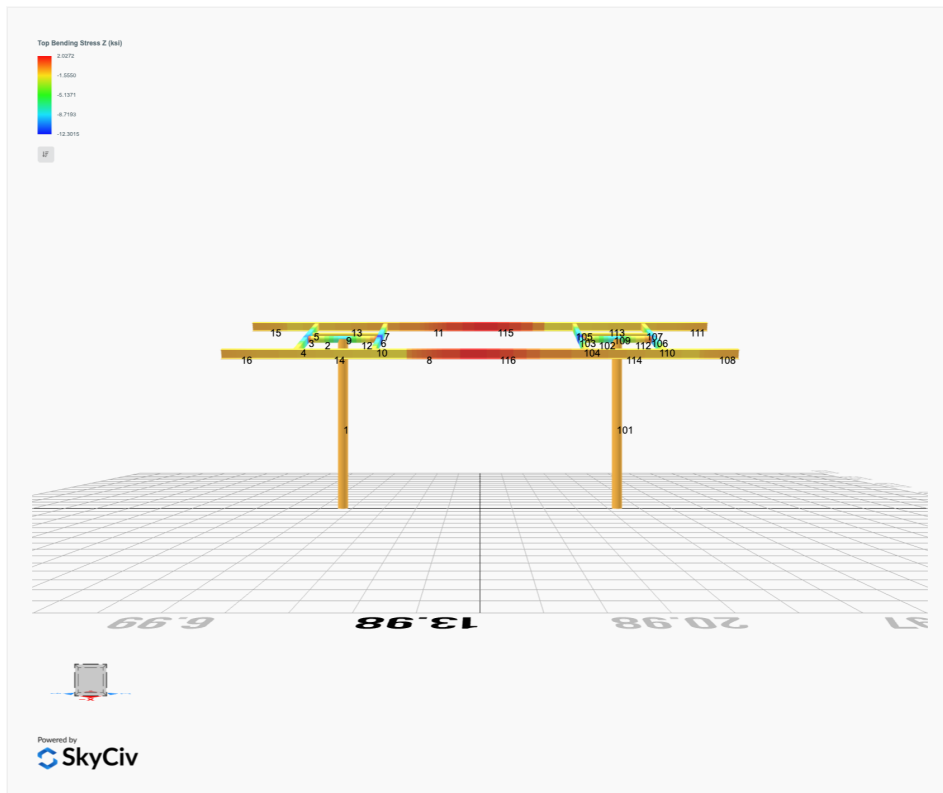
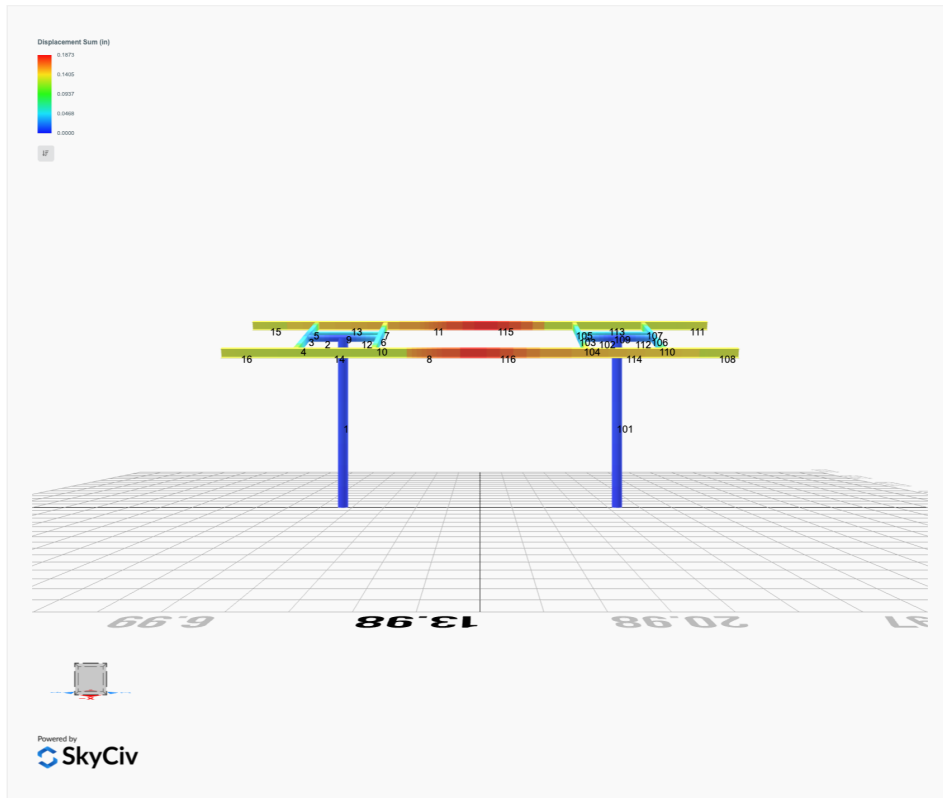

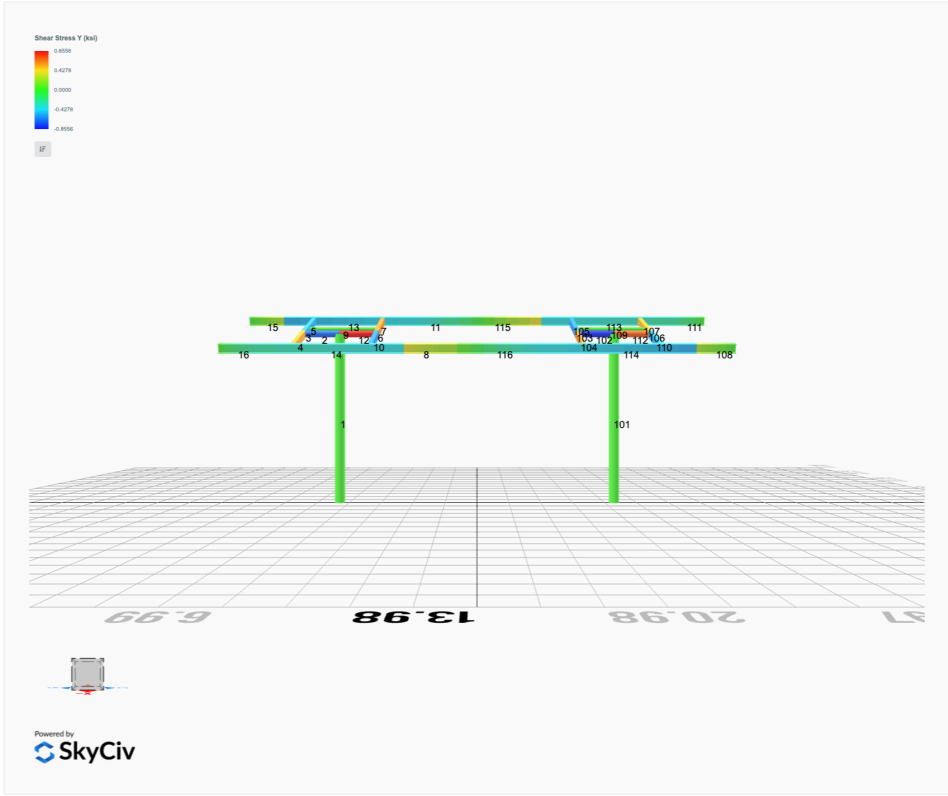
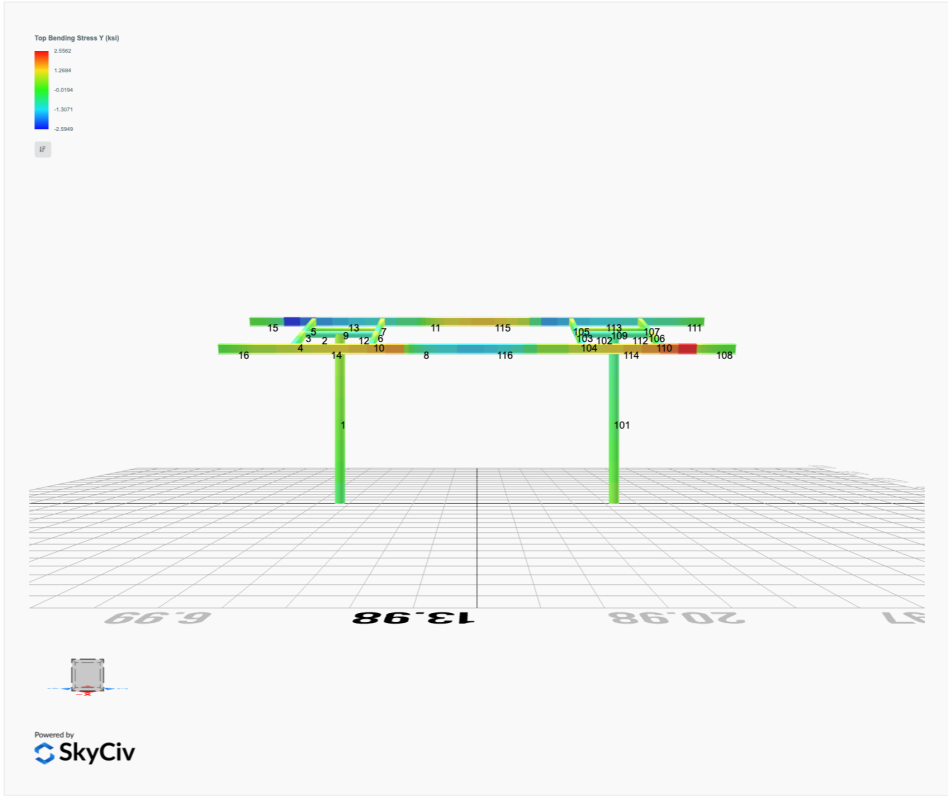

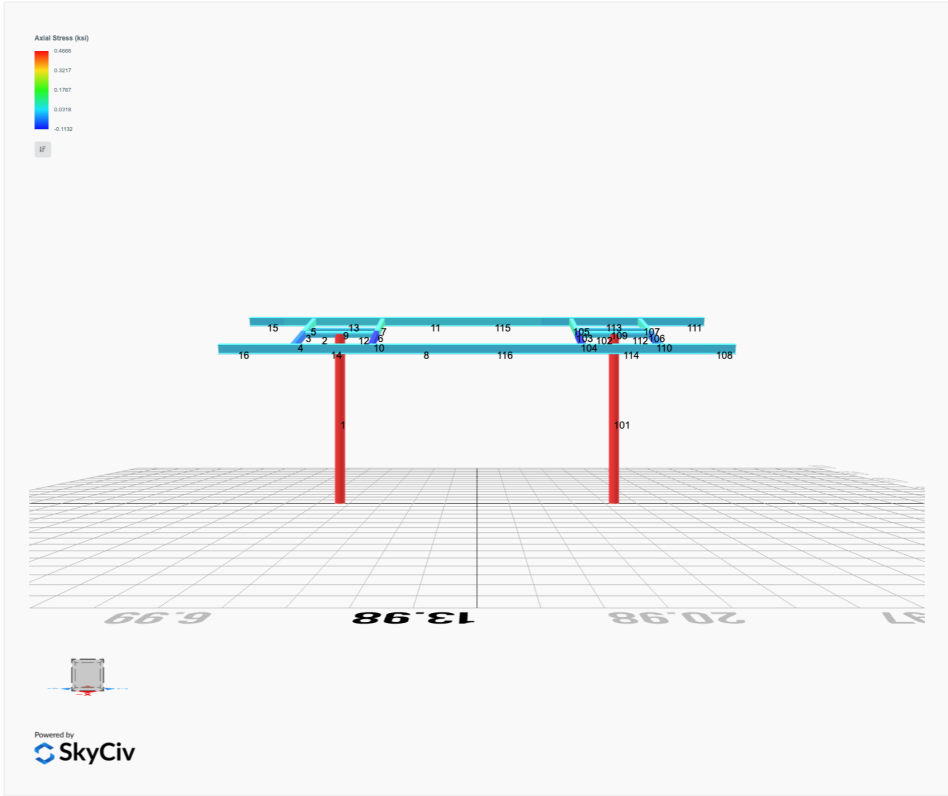

Reaction Forces for Foundation 1 (Node ID#1), (kip, kip-ft)

ASD Load Combination Results

Name	Fx	Fy	Fz	Mx	My	Mz
ULS: 1. D	0.0000	1.6714	0.0258	0.0710	-0.0047	0.0213
ULS: 2. D + L	0.0000	1.6714	0.0258	0.0710	-0.0047	0.0213
ULS: 3. D + (S or Lr or R)	0.0000	4.2758	0.0762	0.2097	-0.0141	0.0276
ULS: 3. D + (S or Lr or R)	0.0000	1.6714	0.0258	0.0710	-0.0047	0.0213
ULS: 4. D + 0.75L + 0.75(S or Lr or R)	0.0000	3.6247	0.0636	0.1751	-0.0117	0.0260
ULS: 4. D + 0.75L + 0.75(S or Lr or R)	0.0000	1.6714	0.0258	0.0710	-0.0047	0.0213
ULS: 5b. D + 0.7E	0.0000	1.6714	0.0258	0.0710	-0.0047	0.0213
ULS: 6b. D + 0.75L + 0.75(0.7)E + 0.75S	0.0000	3.6247	0.0636	0.1751	-0.0117	0.0260
ULS: 8. 0.6D + 0.7E	0.0000	1.0028	0.0155	0.0426	-0.0028	0.0128
ULS: 5a. D + 0.6W_Wind downforce Case A only	-0.7682	4.5384	0.0826	0.2244	-0.0471	8.5008
ULS: 5a. D + 0.6W_Wind downforce Case B only	-0.7682	4.5384	0.0826	0.2244	-0.0471	8.5008
ULS: 5a. D + 0.6W_Wind uplift Case A only	0.5828	-0.5036	-0.0168	-0.0438	0.0273	-3.7812
ULS: 5a. D + 0.6W_Wind uplift Case B only	0.5033	-0.2070	-0.0116	-0.0299	0.0234	-11.6876
ULS: 6a. D + 0.75L + 0.75(0.6)W + 0.75(S or Lr or R)_Wind downforce Case A only	-0.5762	5.7750	0.1062	0.2901	-0.0435	6.3856
ULS: 6a. D + 0.75L + 0.75(0.6)W + 0.75(S or Lr or R)_Wind downforce Case B only	-0.5762	5.7750	0.1062	0.2901	-0.0435	6.3856
ULS: 6a. D + 0.75L + 0.75(0.6)W + 0.75(S or Lr or R)_Wind uplift Case A only	0.4371	1.9934	0.0316	0.0889	0.0122	-2.8259
ULS: 6a. D + 0.75L + 0.75(0.6)W + 0.75(S or Lr or R)_Wind uplift Case B only	0.3775	2.2159	0.0355	0.0994	0.0093	-8.7557
ULS: 6a. D + 0.75L + 0.75(0.6)W + 0.75(S or Lr or R)_Wind downforce Case A only	-0.5762	3.8216	0.0684	0.1861	-0.0365	6.3809
ULS: 6a. D + 0.75L + 0.75(0.6)W + 0.75(S or Lr or R)_Wind downforce Case B only	-0.5762	3.8216	0.0684	0.1861	-0.0365	6.3809
ULS: 6a. D + 0.75L + 0.75(0.6)W + 0.75(S or Lr or R)_Wind uplift Case A only	0.4371	0.0401	-0.0062	-0.0151	0.0193	-2.8306
ULS: 6a. D + 0.75L + 0.75(0.6)W + 0.75(S or Lr or R)_Wind uplift Case B only	0.3775	0.2626	-0.0023	-0.0046	0.0164	-8.7604
ULS: 7. 0.6D + 0.6W_Wind downforce Case A only	-0.7682	3.8699	0.0722	0.1960	-0.0452	8.4923
ULS: 7. 0.6D + 0.6W_Wind downforce Case B only	-0.7682	3.8699	0.0722	0.1960	-0.0452	8.4923
ULS: 7. 0.6D + 0.6W_Wind uplift Case A only	0.5828	-1.1722	-0.0272	-0.0722	0.0292	-3.7897
ULS: 7. 0.6D + 0.6W_Wind uplift Case B only	0.5033	-0.8756	-0.0220	-0.0583	0.0253	-11.6961

Worst Case Reactions LRFD

These calculations are taken directly from the FEA via SkyCiv and are used in the Concrete Checks of the Foundation Module.
Note: Worst case values are assumed as downforce wind load cases.

Result	Value
Axial	8.5619
Shear X	-1.2804
Shear Z	0.1593
Moment X	0.4372
Moment Z	19.9172

Worst Case Reactions ASD

These results are taken from the worst case values in the above table and are used in the Soil Checks in the Foundation Module.
Note: Worst case values are assumed as downforce wind load cases.

Result	Value
Axial	5.7750
Shear X	-0.7682
Shear Z	0.1062
Moment X	0.2901
Moment Z	11.6961

Reaction Forces for Foundation 2 (Node ID#101), (kip, kip-ft)

ASD Load Combination Results

Name	Fx	Fy	Fz	Mx	My	Mz
ULS: 1. D	-0.0000	1.6714	-0.0258	-0.0710	0.0047	0.0213
ULS: 2. D + L	-0.0000	1.6714	-0.0258	-0.0710	0.0047	0.0213
ULS: 3. D + (S or Lr or R)	-0.0000	4.2758	-0.0762	-0.2097	0.0141	0.0276
ULS: 3. D + (S or Lr or R)	-0.0000	1.6714	-0.0258	-0.0710	0.0047	0.0213
ULS: 4. D + 0.75L + 0.75(S or Lr or R)	-0.0000	3.6247	-0.0636	-0.1751	0.0117	0.0260
ULS: 4. D + 0.75L + 0.75(S or Lr or R)	-0.0000	1.6714	-0.0258	-0.0710	0.0047	0.0213
ULS: 5b. D + 0.7E	-0.0000	1.6714	-0.0258	-0.0710	0.0047	0.0213
ULS: 6b. D + 0.75L + 0.75(0.7)E + 0.75S	-0.0000	3.6247	-0.0636	-0.1751	0.0117	0.0260

Name	Fx	Fy	Fz	Mx	My	Mz
ULS: 8. 0.6D + 0.7E	-0.0000	1.0028	-0.0155	-0.0426	0.0028	0.0128
ULS: 5a. D + 0.6W_Wind downforce Case A only	-0.7682	4.5384	-0.0826	-0.2244	0.0471	8.5008
ULS: 5a. D + 0.6W_Wind downforce Case B only	-0.7682	4.5384	-0.0826	-0.2244	0.0471	8.5008
ULS: 5a. D + 0.6W_Wind uplift Case A only	0.5828	-0.5036	0.0168	0.0438	-0.0273	-3.7812
ULS: 5a. D + 0.6W_Wind uplift Case B only	0.5033	-0.2070	0.0116	0.0299	-0.0234	-11.6876
ULS: 6a. D + 0.75L + 0.75(0.6)W + 0.75(S or Lr or R)_Wind downforce Case A only	-0.5762	5.7750	-0.1062	-0.2901	0.0435	6.3856
ULS: 6a. D + 0.75L + 0.75(0.6)W + 0.75(S or Lr or R)_Wind downforce Case B only	-0.5762	5.7750	-0.1062	-0.2901	0.0435	6.3856
ULS: 6a. D + 0.75L + 0.75(0.6)W + 0.75(S or Lr or R)_Wind uplift Case A only	0.4371	1.9934	-0.0316	-0.0889	-0.0122	-2.8259
ULS: 6a. D + 0.75L + 0.75(0.6)W + 0.75(S or Lr or R)_Wind uplift Case B only	0.3775	2.2159	-0.0355	-0.0994	-0.0093	-8.7557
ULS: 6a. D + 0.75L + 0.75(0.6)W + 0.75(S or Lr or R)_Wind downforce Case A only	-0.5762	3.8216	-0.0684	-0.1861	0.0365	6.3809
ULS: 6a. D + 0.75L + 0.75(0.6)W + 0.75(S or Lr or R)_Wind downforce Case B only	-0.5762	3.8216	-0.0684	-0.1861	0.0365	6.3809
ULS: 6a. D + 0.75L + 0.75(0.6)W + 0.75(S or Lr or R)_Wind uplift Case A only	0.4371	0.0401	0.0062	0.0151	-0.0193	-2.8306
ULS: 6a. D + 0.75L + 0.75(0.6)W + 0.75(S or Lr or R)_Wind uplift Case B only	0.3775	0.2626	0.0023	0.0046	-0.0164	-8.7604
ULS: 7. 0.6D + 0.6W_Wind downforce Case A only	-0.7682	3.8699	-0.0722	-0.1960	0.0452	8.4923
ULS: 7. 0.6D + 0.6W_Wind downforce Case B only	-0.7682	3.8699	-0.0722	-0.1960	0.0452	8.4923
ULS: 7. 0.6D + 0.6W_Wind uplift Case A only	0.5828	-1.1722	0.0272	0.0722	-0.0292	-3.7897
ULS: 7. 0.6D + 0.6W_Wind uplift Case B only	0.5033	-0.8756	0.0220	0.0583	-0.0253	-11.6961

Worst Case Reactions LRFD

These calculations are taken directly from the FEA via SkyCiv and are used in the Concrete Checks of the Foundation Module.
Note: Worst case values are assumed as downforce wind load cases.

Result	Value
Axial	8.5619
Shear X	-1.2804
Shear Z	-0.1593
Moment X	-0.4371
Moment Z	19.9176

Worst Case Reactions ASD

These results are taken from the worst case values in the above table and are used in the Soil Checks in the Foundation Module.
Note: Worst case values are assumed as downforce wind load cases.

Result	Value
Axial	5.7750
Shear X	-0.7682
Shear Z	-0.1062
Moment X	-0.2901
Moment Z	11.6961

Project Details

Design Code: AISC 360-16 LRFD
 Provision: LRFD
 Country: United States

User Name: sales@mtsolar.us
 Unit System: imperial



Design Input Information

Design Factors			
Φ_t	Φ_c	Φ_b	Φ_v
0.9	0.9	0.9	0.9

Design Materials			
ID	E (ksi)	F_y (ksi)	F_u (ksi)
1	29000	50	65

Section Dimensions

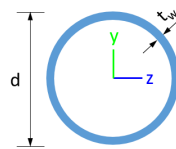

ID	Name	d (in)	t_w (in)				
1	2in Pipe Sch 40	2.38	0.15				
4	4in Pipe Sch 40	4.50	0.24				
7	6in Pipe Sch 40	6.63	0.28				

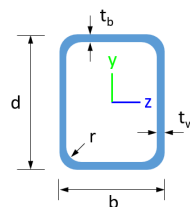

ID	Name	d (in)	b (in)	t_w (in)	t_b (in)	r (in)	
15	HSS5x3x1/8	5.00	3.00	0.12	0.12	0.12	

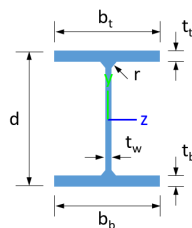

ID	Name	d (in)	t_w (in)	b_t (in)	b_b (in)	t_t (in)	t_b (in)	r (in)
18	W6x9	5.90	0.17	3.94	3.94	0.21	0.21	0.25

Section Properties

ID	Name	A (in ²)	J (in ⁴)	I_{yp} (in ⁴)	I_{zp} (in ⁴)	I_w (in ⁶)	S_{yp} (in ³)	S_{zp} (in ³)
1	2in Pipe Sch 40	1.07	1.33	0.67	0.67	0.00	0.76	0.76
4	4in Pipe Sch 40	3.17	14.47	7.23	7.23	0.00	4.31	4.31
7	6in Pipe Sch 40	5.58	56.28	28.14	28.14	0.00	11.28	11.28

15	HSS5x3x1/8	1.77	6.02	2.75	6.03	152.35	2.07	2.93
18	W6x9	2.68	0.04	2.20	16.40	17.70	1.72	6.23

Member Properties								
Member ID	Section ID	K _z L (ft)	K _y L (ft)	L _b (ft)	C _b	L	S	T
1	7	19.43	19.43	9.25	-	3	2	1
2	4	2.00	2.00	2.00	-	3	2	1
3	15	1.42	1.42	1.42	1.18,1.18,1.18,1.18,1.18,1.18,1.18,1.18,1.10,1.17,1.18,1.18,1.17,1.17,1.18,1.18,1.18,1.18,1.18,1.18,1.33,1.17,1.18,1.18,1.17,1.17	3	2	1
4	15	3.75	3.75	3.75	1.68,1.68,1.68,1.67,1.68,1.68,1.67,1.67,1.65,1.68,1.67,1.67,1.66,1.68,1.67,1.67,1.67,1.67,1.67,1.67,1.63,1.68,1.67,1.67,1.66,1.68	3	2	1
5	15	2.33	2.33	2.33	1.68,1.67,1.68,1.67,1.67,1.68,1.67,1.67,1.59,1.66,1.67,1.67,1.66,1.66,1.67,1.67,1.67,1.67,1.67,1.67,1.67,1.95,1.66,1.67,1.67,1.66,1.66	3	2	1
6	15	1.42	1.42	1.42	1.19,1.18,1.19,1.18,1.19,1.19,1.18,1.18,1.12,1.18,1.18,1.18,1.17,1.18,1.18,1.18,1.18,1.18,1.18,1.18,1.35,1.17,1.18,1.18,1.17,1.18	3	2	1
7	15	2.33	2.33	2.33	1.68,1.67,1.68,1.67,1.67,1.68,1.67,1.67,1.61,1.66,1.67,1.67,1.66,1.66,1.67,1.67,1.67,1.67,1.67,1.67,2.01,1.66,1.67,1.67,1.66,1.66	3	2	1
8	18	2.05	2.05	2.05	1.28,1.28,1.28,1.28,1.28,1.28,1.28,1.28,1.29,1.30,1.28,1.28,1.29,1.31,1.28,1.28,1.28,1.29,1.28,1.28,1.29,1.30,1.28,1.28,1.28,1.33	3	2	1
9	1	4.00	4.00	4.00	-	3	2	1
10	15	3.75	3.75	3.75	1.68,1.68,1.68,1.67,1.68,1.68,1.67,1.67,1.65,1.68,1.67,1.67,1.66,1.68,1.67,1.67,1.67,1.67,1.67,1.67,1.63,1.68,1.67,1.67,1.66,1.68	3	2	1
11	18	2.05	2.05	2.05	1.29,1.29,1.29,1.29,1.29,1.29,1.29,1.29,1.24,1.30,1.29,1.29,1.28,1.29,1.29,1.29,1.29,1.28,1.29,1.29,1.99,1.30,1.29,1.29,1.28,1.29	3	2	1
12	4	2.00	2.00	2.00	-	3	2	1
13	18	1.75	1.75	1.75	2.30,2.30,2.30,2.30,2.30,2.30,2.30,2.30,2.15,2.28,2.30,2.30,2.32,2.29,2.30,2.30,2.30,2.32,2.30,2.30,1.51,2.28,2.30,2.30,2.31,2.29	3	2	1
14	18	1.75	1.75	1.75	1.48,1.48	3	2	1
15	18	2.00	2.00	2.00	2.33,2.33	3	2	1
16	18	2.00	2.00	2.00	2.33,2.33	3	2	1
17	18	4.00	4.00	4.00	1.37,1.37,1.37,1.37,1.37,1.37,1.38,1.38,1.20,1.50,1.38,1.38,1.33,1.46,1.37,1.37,1.38,1.30,1.38,1.38,1.28,1.52,1.38,1.38,1.34,1.45	3	2	1
18	18	1.75	1.75	1.75	1.48,1.48	3	2	1
19	18	4.00	4.00	4.00	1.35,1.36,1.35,1.36,1.35,1.35,1.35,1.35,1.43,1.53,1.35,1.35,1.40,1.80,1.35,1.35,1.34,1.39,1.35,1.35,1.46,1.51,1.35,1.35,1.39,2.19	3	2	1
20	18	1.75	1.75	1.75	2.31,2.31,2.31,2.31,2.31,2.31,2.31,2.31,2.30,2.27,2.31,2.31,2.30,2.25,2.31,2.31,2.31,2.30,2.31,2.31,2.30,2.28,2.31,2.31,2.30,2.24	3	2	1
21	18	4.00	4.00	4.00	1.37,1.37,1.37,1.37,1.37,1.37,1.38,1.38,1.20,1.50,1.38,1.38,1.33,1.46,1.37,1.37,1.38,1.30,1.38,1.38,1.28,1.52,1.38,1.38,1.34,1.45	3	2	1
22	18	1.75	1.75	1.75	2.30,2.30,2.30,2.30,2.30,2.30,2.30,2.30,2.15,2.28,2.30,2.30,2.32,2.29,2.30,2.30,2.30,2.32,2.30,2.30,1.51,2.28,2.30,2.30,2.31,2.29	3	2	1
23	18	4.00	4.00	4.00	1.35,1.36,1.35,1.36,1.35,1.35,1.35,1.35,1.43,1.53,1.35,1.35,1.40,1.79,1.35,1.35,1.34,1.39,1.35,1.35,1.46,1.51,1.35,1.35,1.39,2.19	3	2	1

24	18	1.75	1.75	1.75	1.48,1.48,1.48,1.48,1.48,1.48,1.48,1.48,1.48,1.48,1.48,1.48,1.48,1.48,1.48,1.48,1.48,1.48,1.48,1.48	300	200	1
101	7	19.43	19.43	9.25	-	300	200	1
102	4	2.00	2.00	2.00	-	300	200	1
103	15	1.42	1.42	1.42	1.19,1.18,1.19,1.18,1.19,1.19,1.18,1.18,1.12,1.18,1.18,1.18,1.17,1.18,1.18,1.18,1.18,1.18,1.18,1.18	300	200	1
104	15	3.75	3.75	3.75	1.68,1.68,1.68,1.67,1.68,1.68,1.67,1.67,1.65,1.68,1.67,1.67,1.66,1.68,1.67,1.67,1.67,1.67,1.67,1.67,1.67	300	200	1
105	15	2.33	2.33	2.33	1.68,1.67,1.68,1.67,1.67,1.68,1.67,1.67,1.61,1.66,1.67,1.67,1.66,1.66,1.67,1.67,1.67,1.67,1.67,1.67	300	200	1
106	15	1.42	1.42	1.42	1.18,1.18,1.18,1.18,1.18,1.18,1.18,1.18,1.10,1.17,1.18,1.18,1.17,1.17,1.18,1.18,1.18,1.18,1.18,1.18	300	200	1
107	15	2.33	2.33	2.33	1.68,1.67,1.68,1.67,1.67,1.68,1.67,1.67,1.59,1.66,1.67,1.67,1.66,1.66,1.67,1.67,1.67,1.67,1.67,1.67	300	200	1
108	18	2.00	2.00	2.00	2.33,2.33,2.33,2.33,2.33,2.33,2.33,2.33,2.33,2.33,2.33,2.33,2.33,2.33,2.33,2.33,2.33,2.33,2.33,2.33	300	200	1
109	1	4.00	4.00	4.00	-	300	200	1
110	15	3.75	3.75	3.75	1.68,1.68,1.68,1.67,1.68,1.68,1.67,1.67,1.65,1.68,1.67,1.67,1.66,1.68,1.67,1.67,1.67,1.67,1.67,1.67	300	200	1
111	18	2.00	2.00	2.00	2.33,2.33,2.33,2.33,2.33,2.33,2.33,2.33,2.33,2.33,2.33,2.33,2.33,2.33,2.33,2.33,2.33,2.33,2.33,2.33	300	200	1
112	4	2.00	2.00	2.00	-	300	200	1
113	18	1.75	1.75	1.75	1.48,1.48,1.48,1.48,1.48,1.48,1.48,1.48,1.48,1.48,1.48,1.48,1.48,1.48,1.48,1.48,1.48,1.48,1.48,1.48	300	200	1
114	18	1.75	1.75	1.75	2.31,2.31,2.31,2.31,2.31,2.31,2.31,2.31,2.30,2.27,2.31,2.31,2.30,2.25,2.31,2.31,2.31,2.30,2.31,2.31,2.30,2.28,2.31,2.31,2.30,2.24	300	200	1
115	18	5.45	5.45	5.45	1.09,1.09,1.09,1.09,1.09,1.09,1.09,1.09,1.09,1.09,1.08,1.09,1.09,1.09,1.09,1.09,1.09,1.09,1.09,1.09	300	200	1
116	18	5.45	5.45	5.45	1.09,1.09,1.09,1.09,1.09,1.09,1.09,1.09,1.09,1.09,1.09,1.09,1.09,1.09,1.10,1.09,1.09,1.09,1.09,1.09	300	200	1

Member Design Capacity

Member ID	$\Phi_t P_n$ (kip)	$\Phi_c P_n$ (kip)	$\Phi_b M_{zn}$ (k-ft)	$\Phi_b M_{yn}$ (k-ft)	$\Phi_v V_{yn}$ (kip)	$\Phi_v V_{zn}$ (kip)
1	251.16	114.15	42.30	42.30	75.35	75.35
2	142.83	140.22	16.17	16.17	42.85	42.85
3	79.65	73.55	10.99	4.60	29.14	16.61
4	79.65	68.91	10.99	4.60	29.14	16.61
5	79.65	72.20	10.99	4.60	29.14	16.61
6	79.65	73.55	10.99	4.60	29.14	16.61
7	79.65	72.20	10.99	4.60	29.14	16.61
8	120.60	114.27	23.36	6.45	30.09	45.74
9	48.35	36.84	2.85	2.85	14.51	14.51
10	79.65	68.91	10.99	4.60	29.14	16.61
11	120.60	114.27	23.36	6.45	30.09	45.74
12	142.83	140.22	16.17	16.17	42.85	42.85
13	120.60	115.95	23.36	6.45	30.09	45.74
14	120.60	115.95	23.36	6.45	30.09	45.74

15	120.60	114.57	23.36	6.45	30.09	45.74
16	120.60	114.57	23.36	6.45	30.09	45.74
17	120.60	98.23	23.36	6.45	30.09	45.74
18	120.60	115.95	23.36	6.45	30.09	45.74
19	120.60	98.23	23.36	6.45	30.09	45.74
20	120.60	115.95	23.36	6.45	30.09	45.74
21	120.60	98.23	23.36	6.45	30.09	45.74
22	120.60	115.95	23.36	6.45	30.09	45.74
23	120.60	98.23	23.36	6.45	30.09	45.74
24	120.60	115.95	23.36	6.45	30.09	45.74
101	251.16	114.15	42.30	42.30	75.35	75.35
102	142.83	140.22	16.17	16.17	42.85	42.85
103	79.65	73.55	10.99	4.60	29.14	16.61
104	79.65	68.91	10.99	4.60	29.14	16.61
105	79.65	72.20	10.99	4.60	29.14	16.61
106	79.65	73.55	10.99	4.60	29.14	16.61
107	79.65	72.20	10.99	4.60	29.14	16.61
108	120.60	114.57	23.36	6.45	30.09	45.74
109	48.35	36.84	2.85	2.85	14.51	14.51
110	79.65	68.91	10.99	4.60	29.14	16.61
111	120.60	114.57	23.36	6.45	30.09	45.74
112	142.83	140.22	16.17	16.17	42.85	42.85
113	120.60	115.95	23.36	6.45	30.09	45.74
114	120.60	115.95	23.36	6.45	30.09	45.74
115	120.60	82.39	21.98	6.45	30.09	45.74
116	120.60	82.39	22.18	6.45	30.09	45.74

Design Ratio

Member ID	P	M _z	M _y	V _y	V _z	(P,M _z ,M _y)	Worst LC	KL/r	δ	Status
1	0.075	0.471	0.024	0.017	0.002	0.472	#16	0.519	Not Required	Pass
2	0.000	0.418	0.080	0.092	0.015	0.476	#13	0.079	Not Required	Pass
3	0.005	0.684	0.047	0.069	0.008	0.726	#21	0.068	Not Required	Pass
4	0.004	0.639	0.067	0.065	0.010	0.707	#21	0.120	Not Required	Pass
5	0.005	0.424	0.046	0.069	0.006	0.429	#21	0.112	Not Required	Pass
6	0.006	0.750	0.090	0.076	0.015	0.843	#21	0.068	Not Required	Pass
7	0.006	0.465	0.090	0.075	0.013	0.489	#21	0.112	Not Required	Pass
8	0.000	0.108	0.038	0.037	0.005	0.146	#21	0.136	Not Required	Pass
9	0.001	0.071	0.035	0.001	0.001	0.106	#21	0.203	Not Required	Pass
10	0.006	0.702	0.075	0.071	0.010	0.757	#21	0.120	Not Required	Pass
11	0.001	0.114	0.037	0.039	0.005	0.150	#21	0.136	Not Required	Pass
12	0.001	0.482	0.085	0.103	0.015	0.542	#21	0.079	Not Required	Pass
13	0.001	0.070	0.084	0.057	0.007	0.155	#21	0.116	Not Required	Pass
14	0.000	0.089	0.062	0.037	0.005	0.150	#21	Not Required	Not Required	Pass
15	0.000	0.027	0.018	0.021	0.002	0.044	#21	Not Required	Not Required	Pass
16	0.000	0.025	0.018	0.020	0.002	0.043	#21	Not Required	Not Required	Pass
17	0.001	0.112	0.032	0.027	0.003	0.144	#21	0.177	Not Required	Pass
18	0.000	0.094	0.062	0.039	0.005	0.156	#21	Not Required	Not Required	Pass
19	0.002	0.109	0.035	0.025	0.003	0.124	#21	0.265	Not Required	Pass
20	0.000	0.065	0.082	0.054	0.007	0.147	#21	0.116	Not Required	Pass
21	0.001	0.112	0.032	0.027	0.003	0.144	#21	0.177	Not Required	Pass
22	0.001	0.070	0.084	0.057	0.007	0.155	#21	0.116	Not Required	Pass
23	0.002	0.109	0.035	0.025	0.003	0.124	#21	0.265	Not Required	Pass

24	0.000	0.089	0.062	0.037	0.005	0.150	#21	Not Required	Not Required	Pass
101	0.075	0.471	0.024	0.017	0.002	0.472	#16	0.519	Not Required	Pass
102	0.001	0.482	0.085	0.103	0.015	0.542	#21	0.079	Not Required	Pass
103	0.006	0.750	0.090	0.076	0.015	0.843	#21	0.068	Not Required	Pass
104	0.006	0.702	0.075	0.071	0.010	0.757	#21	0.120	Not Required	Pass
105	0.006	0.465	0.090	0.075	0.013	0.489	#21	0.112	Not Required	Pass
106	0.005	0.684	0.047	0.069	0.008	0.726	#21	0.068	Not Required	Pass
107	0.005	0.424	0.046	0.069	0.006	0.429	#21	0.112	Not Required	Pass
108	0.000	0.025	0.018	0.020	0.002	0.043	#21	Not Required	Not Required	Pass
109	0.001	0.071	0.035	0.001	0.001	0.106	#21	0.203	Not Required	Pass
110	0.004	0.639	0.067	0.065	0.010	0.707	#21	0.120	Not Required	Pass
111	0.000	0.027	0.018	0.021	0.002	0.044	#21	Not Required	Not Required	Pass
112	0.000	0.418	0.080	0.092	0.015	0.476	#13	0.079	Not Required	Pass
113	0.000	0.094	0.062	0.039	0.005	0.156	#21	Not Required	Not Required	Pass
114	0.000	0.065	0.082	0.054	0.007	0.147	#21	0.116	Not Required	Pass
115	0.002	0.139	0.049	0.039	0.005	0.189	#21	0.361	Not Required	Pass
116	0.001	0.132	0.050	0.037	0.005	0.182	#21	0.361	Not Required	Pass

Definitions

Φ_t	Safety factor for tensile
Φ_c	Safety factor for compression
Φ_b	Safety factor for flexure
Φ_v	Safety factor for shear
E	Modulus of elasticity
F_y	Specified minimum yield stress
F_u	Specified minimum tensile strength
A	Cross-sectional area
J	Torsional constant
I_{yp}	Moment of inertia about the Y axes
I_{zp}	Moment of inertia about the Z axes
I_w	Warping constant
S_{yp}	Plastic section modulus about the Y axis
S_{zp}	Plastic section modulus about the Z axis
KL	Effective length
C_b	Buckling modification factor (from all load combinations)
L_b	Length between braced points
LST	Limited slenderness for tension
LSC	Limited slenderness for compression
LD	Limited deflection
P_n	Nominal axial strength (tension/compression)
M_n	Nominal flexural strength (about Z/Y axis)
V_n	Nominal shear strength (along Z/Y axis)
P	Design ratio in case of axial force
M_z	Design ratio in case of bending about Z axis
M_y	Design ratio in case of bending about Y axis
V_y	Design ratio in case of shear along Y axis
V_z	Design ratio in case of shear along Z axis
(P, M_z, M_y)	Design ratio in case of axial force and bending action
KL/r	Design ratio in case of section slenderness
δ	Design ratio in case of member deflection
OK	Capacity is provided
NG	Capacity is not provided

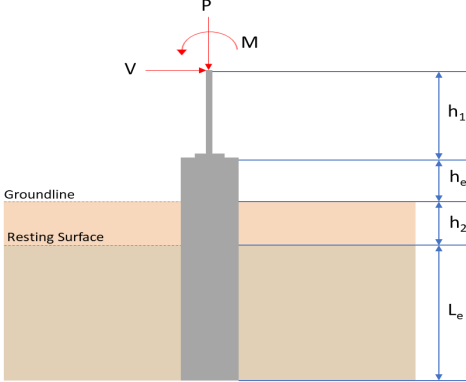
REFERENCES	CALCULATIONS	RESULTS																										
	<p>SkyCiv Foundation Design Pile Foundation</p> <p>Design Information : Design code : IBC 2021 (International Building Code) Unit System : Imperial</p>																											
	<p>Pile Input</p>  <p>Geometry Pile shape: rectangular $b = 48$ in - Pile width $D = 48$ in - Pile depth $L = 5$ ft - Total pile length $h_1 = 0$ ft - Lateral load height from the top of the pile, $h_2 = 0$ ft - Depth to resting surface $h_e = 0$ ft - Length of pile above the ground</p> <p>Tabulation of Soil Parameters</p> <table border="1" data-bbox="416 1102 1193 1193"> <thead> <tr> <th>Layer</th> <th>Label</th> <th>Allowable Bearing Pressure (q_a) (psf)</th> <th>Allowable Lateral Pressure (R) (psf/ft)</th> </tr> </thead> <tbody> <tr> <td>1</td> <td>Sand, silty sand, clayey sand, silty gravel & clayey gravel</td> <td>2000.000</td> <td>150.000</td> </tr> </tbody> </table> <p>Tabulation of Loads</p> <table border="1" data-bbox="676 1288 935 1458"> <thead> <tr> <th>Load Component</th> <th>ASD</th> <th>LRFD</th> </tr> </thead> <tbody> <tr> <td>P (kip)</td> <td>5.775</td> <td>8.562</td> </tr> <tr> <td>V_x (kip)</td> <td>-0.768</td> <td>-1.280</td> </tr> <tr> <td>V_z (kip)</td> <td>0.106</td> <td>0.159</td> </tr> <tr> <td>M_x (kipft)</td> <td>0.290</td> <td>0.437</td> </tr> <tr> <td>M_z (kipft)</td> <td>11.696</td> <td>19.917</td> </tr> </tbody> </table> <p>Material Properties $f'_{ck} = 3$ ksi - Concrete strength,</p>	Layer	Label	Allowable Bearing Pressure (q_a) (psf)	Allowable Lateral Pressure (R) (psf/ft)	1	Sand, silty sand, clayey sand, silty gravel & clayey gravel	2000.000	150.000	Load Component	ASD	LRFD	P (kip)	5.775	8.562	V_x (kip)	-0.768	-1.280	V_z (kip)	0.106	0.159	M_x (kipft)	0.290	0.437	M_z (kipft)	11.696	19.917	
Layer	Label	Allowable Bearing Pressure (q_a) (psf)	Allowable Lateral Pressure (R) (psf/ft)																									
1	Sand, silty sand, clayey sand, silty gravel & clayey gravel	2000.000	150.000																									
Load Component	ASD	LRFD																										
P (kip)	5.775	8.562																										
V_x (kip)	-0.768	-1.280																										
V_z (kip)	0.106	0.159																										
M_x (kipft)	0.290	0.437																										
M_z (kipft)	11.696	19.917																										
	<p>Required depth to resist lateral loads (ASD) H - Point of application of the lateral load</p> $H = h_1 + h_2 + h_e$ $H = (0 \text{ ft}) + (0 \text{ ft}) + (0 \text{ ft})$ $H = 0 \text{ ft}$ <p>Considering x-direction: H_o - Lateral force per length of pile,</p> $H_o = \frac{V_x}{1.57 D}$ $H_o = \frac{(-0.768 \text{ kip})}{1.57 \times (48 \text{ in})}$ $H_o = -0.12229 \text{ kip/ft}$ <p>M_o - Moment per length of pile,</p> $M_o = \frac{M_z + (V_x H)}{1.57 D}$																											

$$M_o = \frac{(11.696 \text{ kipft}) + ((-0.768 \text{ kip}) \times (0 \text{ ft}))}{1.57 \times (48 \text{ in})}$$

$$M_o = 1.8624 \text{ kipft/ft}$$

Required depth of embedment in earth:

$$L_x^3 - \left(14.14 \times \frac{H_o \times L_x}{R}\right) - \left(18.85 \times \frac{M_o}{R}\right) = 0$$

Solving the cubic equation:

$L_{e,x} = 4.8413 \text{ ft}$ - Required depth in x-direction,

Considering z-direction:

H_o - Lateral force per length of pile,

$$H_o = \frac{V_z}{1.57 b}$$

$$H_o = \frac{(0.106 \text{ kip})}{1.57 \times (48 \text{ in})}$$

$$H_o = 0.016879 \text{ kip/ft}$$

M_o - Moment per length of pile,

$$M_o = \frac{M_x + (V_z H)}{1.57 b}$$

$$M_o = \frac{(0.29 \text{ kipft}) + ((0.106 \text{ kip}) \times (0 \text{ ft}))}{1.57 \times (48 \text{ in})}$$

$$M_o = 0.046178 \text{ kipft/ft}$$

Required depth of embedment in earth:

$$L_z^3 - \left(14.14 \times \frac{H_o \times L_z}{R}\right) - \left(18.85 \times \frac{M_o}{R}\right) = 0$$

Solving the cubic equation:

$L_{e,z} = 1.763 \text{ ft}$ - Required depth in z-direction,

Minimum embedded depth required:

$L_{e,req}$ - Depth of pile required,

$$L_{e,req} = \text{MAX}[L_{e,x}, L_{e,z}]$$

$$L_{e,req} = \text{MAX}[(4.8413 \text{ ft}), (1.763 \text{ ft})]$$

$$L_{e,req} = 4.841 \text{ ft}$$

L_e - Actual embedded length of pile,

$$L_e = L - h_c - h_2$$

$$L_e = (5 \text{ ft}) - (0 \text{ ft}) - (0 \text{ ft})$$

$$L_e = 5 \text{ ft}$$

Ratio - Embedded depth

$$\text{Ratio} = \frac{L_{e,req}}{L_e}$$

$$\text{Ratio} = \frac{(4.841 \text{ ft})}{(5 \text{ ft})}$$

$$\text{Ratio} = 0.9682$$

Status: **PASS**
Ratio: **0.970**

End-bearing Capacity (ASD)

A - Pile cross-section area

$$A = b D$$

$$A = (48 \text{ in}) \times (48 \text{ in})$$

$$A = 16 \text{ ft}^2$$

q - End-bearing pressure

$$q = \frac{P_c}{A}$$

$$q = \frac{(5.775 \text{ kip})}{(16 \text{ ft}^2)}$$

$$q = 0.36094 \text{ kip/ft}^2$$

$$q = 0.00094 \text{ kip/ft}$$

Check bearing capacity ratio:

Ratio - Capacity

$$\text{Ratio} = \frac{q}{q_a}$$

$$\text{Ratio} = \frac{(0.36094 \text{ kip/ft}^2)}{(2000 \text{ psf})}$$

$$\text{Ratio} = 0.18047$$

Status: **PASS**
Ratio: **0.180**

Czerniak

Lateral Soil Pressure (ASD):

L/D - Length to least lateral dimension ratio,

$$L/D = \frac{L}{D}$$

$$L/D = \frac{(5 \text{ ft})}{(48 \text{ in})}$$

$$L/D = 1.25$$

Since $L/D \leq 10$,

Pile is short.

Considering x-direction:

$H_o = -0.12229 \text{ kip/ft}$ - Lateral force per length of pile,

$M_o = 1.8624 \text{ kipft/ft}$ - Overturning moment per length of pile,

a - Distance from resting surface to pivot point,

$$a = \frac{(4 M_o L_e) + (3 H_o L_e^2)}{(6 M_o) + (4 H_o L_e)}$$

$$a = \frac{(4 \times (1.8624 \text{ kipft/ft}) \times (5 \text{ ft})) + (3 \times (-0.12229 \text{ kip/ft}) \times (5 \text{ ft})^2)}{(6 \times (1.8624 \text{ kipft/ft})) + (4 \times (-0.12229 \text{ kip/ft}) \times (5 \text{ ft}))}$$

$$a = 3.4082 \text{ ft}$$

p - Earth pressure against the pile at distance $a/2$ from resting surface,

$$p = \frac{0.75 [(4 M_o) + (3 H_o L_e)]^2}{L_e^2 [(3 M_o) + (2 H_o L_e)]}$$

$$p = \frac{0.75 \times [(4 \times (1.8624 \text{ kipft/ft})) + (3 \times (-0.12229 \text{ kip/ft}) \times (5 \text{ ft}))]^2}{(5 \text{ ft})^2 \times [(3 \times (1.8624 \text{ kipft/ft})) + (2 \times (-0.12229 \text{ kip/ft}) \times (5 \text{ ft}))]}$$

$$p = 0.21674 \text{ kip/ft}^2$$

s - Earth pressure against the pile at distance L_e ,

$$s = \frac{6 [(2 M_o) + (H_o L_e)]}{L_e^2}$$

$$s = \frac{6 \times [(2 \times (1.8624 \text{ kipft/ft})) + ((-0.12229 \text{ kip/ft}) \times (5 \text{ ft}))]}{(5 \text{ ft})^2}$$

$$s = 0.74721 \text{ kip/ft}^2$$

Check lateral soil pressure capacity:

p_a - Allowable lateral soil pressure at depth $a/2$,

$$p_a = R \frac{a}{2}$$

$$p_a = (150 \text{ psf/ft}) \times \frac{(3.4082 \text{ ft})}{2}$$

$$p_a = 0.25561 \text{ kip/ft}^2$$

Ratio - Lateral soil capacity

$$\text{Ratio} = \frac{p}{p_a}$$

$$\text{Ratio} = \frac{(0.21674 \text{ kip/ft}^2)}{(0.25561 \text{ kip/ft}^2)}$$

$$\text{Ratio} = 0.84794$$

p_a - Allowable lateral soil pressure at depth L_e ,

Status: **PASS**
Ratio: **0.850**

	$p_s = R L_e$ $p_s = (150 \text{ psf/ft}) \times (5 \text{ ft})$ $p_s = 0.75 \text{ kip/ft}^2$ <p>Ratio - Lateral soil capacity</p> $\text{Ratio} = \frac{s}{p_s}$ $\text{Ratio} = \frac{(0.74721 \text{ kip/ft}^2)}{(0.75 \text{ kip/ft}^2)}$ $\text{Ratio} = 0.99628$	Status: PASS Ratio: 1.000
	<p>Considering z-direction:</p> <p>$H_o = 0.016879 \text{ kip/ft}$ - Lateral force per length of pile, $M_o = 0.046178 \text{ kipft/ft}$ - Overturning moment per length of pile, a - Distance from resting surface to pivot point,</p> $a = \frac{(4 M_o L_e) + (3 H_o L_e^2)}{(6 M_o) + (4 H_o L_e)}$ $a = \frac{(4 \times (0.046178 \text{ kipft/ft}) \times (5 \text{ ft})) + (3 \times (0.016879 \text{ kip/ft}) \times (5 \text{ ft})^2)}{(6 \times (0.046178 \text{ kipft/ft})) + (4 \times (0.016879 \text{ kip/ft}) \times (5 \text{ ft}))}$ $a = 3.5622 \text{ ft}$ <p>p - Earth pressure against the pile at distance $a/2$ from resting surface,</p> $p = \frac{0.75 [(4 M_o) + (3 H_o L_e)]^2}{L_e^2 [(3 M_o) + (2 H_o L_e)]}$ $p = \frac{0.75 \times [(4 \times (0.046178 \text{ kipft/ft})) + (3 \times (0.016879 \text{ kip/ft}) \times (5 \text{ ft}))]^2}{(5 \text{ ft})^2 \times [(3 \times (0.046178 \text{ kipft/ft})) + (2 \times (0.016879 \text{ kip/ft}) \times (5 \text{ ft}))]}$ $p = 0.018718 \text{ kip/ft}^2$ <p>s - Earth pressure against the pile at distance L_e,</p> $s = \frac{6 [(2 M_o) + (H_o L_e)]}{L_e^2}$ $s = \frac{6 \times [(2 \times (0.046178 \text{ kipft/ft})) + ((0.016879 \text{ kip/ft}) \times (5 \text{ ft}))]}{(5 \text{ ft})^2}$ $s = 0.04242 \text{ kip/ft}^2$ <p>Check lateral soil pressure capacity:</p> <p>p_a - Allowable lateral soil pressure at depth $a/2$,</p> $p_a = R \frac{a}{2}$ $p_a = (150 \text{ psf/ft}) \times \frac{(3.5622 \text{ ft})}{2}$ $p_a = 0.26716 \text{ kip/ft}^2$ <p>Ratio - Lateral soil capacity</p> $\text{Ratio} = \frac{p}{p_a}$ $\text{Ratio} = \frac{(0.018718 \text{ kip/ft}^2)}{(0.26716 \text{ kip/ft}^2)}$ $\text{Ratio} = 0.070064$ <p>p_s - Allowable lateral soil pressure at depth L_e,</p> $p_s = R L_e$ $p_s = (150 \text{ psf/ft}) \times (5 \text{ ft})$ $p_s = 0.75 \text{ kip/ft}^2$ <p>Ratio - Lateral soil capacity</p> $\text{Ratio} = \frac{s}{p_s}$	Status: PASS Ratio: 0.070

$$Ratio = \frac{(0.04242 \text{ kip/ft}^2)}{(0.75 \text{ kip/ft}^2)}$$

$$Ratio = 0.056561$$

Status: **PASS**
Ratio: **0.060**

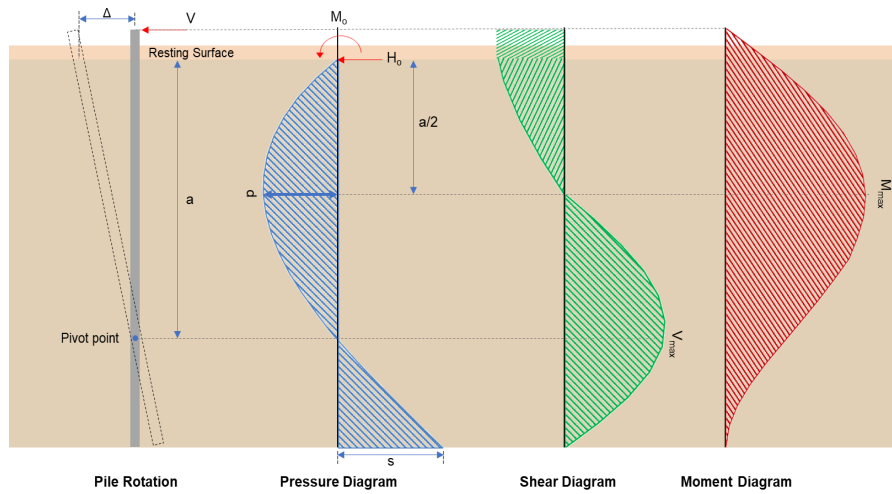

Shear force and Bending moment (x-direction, LRF)

H_o - Lateral force per length of pile,

$$H_o = \frac{V_e}{1.57 D}$$

$$H_o = \frac{(-1.28 \text{ kip})}{1.57 \times (48 \text{ in})}$$

$$H_o = -0.20382 \text{ kip/ft}$$

M_o - Moment per length of pile,

$$M_o = \frac{M_e + (V_e H)}{1.57 D}$$

$$M_o = \frac{(19.917 \text{ kipft}) + ((-1.28 \text{ kip}) \times (0 \text{ ft}))}{1.57 \times (48 \text{ in})}$$

$$M_o = 3.1715 \text{ kipft/ft}$$

E - Distance from lateral load to resisting surface,

$$E = \frac{M_o}{H_o}$$

$$E = \frac{(3.1715 \text{ kipft/ft})}{(-0.20382 \text{ kip/ft})}$$

$$E = 15.56 \text{ ft}$$

a - Distance from resting surface to pivot point,

$$a = \frac{(4 M_o L_e) + (3 H_o L_e^2)}{(6 M_o) + (4 H_o L_e)}$$

$$a = \frac{(4 \times (3.1715 \text{ kipft/ft}) \times (5 \text{ ft})) + (3 \times (-0.20382 \text{ kip/ft}) \times (5 \text{ ft})^2)}{(6 \times (3.1715 \text{ kipft/ft})) + (4 \times (-0.20382 \text{ kip/ft}) \times (5 \text{ ft}))}$$

$$a = 3.4068 \text{ ft}$$

V_{max} - Max shear force located at depth a ,

$$V_{max} = (H_o D) \left[1 - \left[3 \left(\frac{4 E}{L_e} + 3 \right) \left(\frac{a}{L_e} \right)^2 \right] + \left[4 \left(\frac{3 E}{L_e} + 2 \right) \left(\frac{a}{L_e} \right)^3 \right] \right]$$

$$V_{max} = ((-0.20382 \text{ kip/ft}) \times (48 \text{ in})) \times \left[1 - \left[3 \times \left(\frac{4 \times (15.56 \text{ ft})}{(5 \text{ ft})} + 3 \right) \times \left(\frac{(3.4068 \text{ ft})}{(5 \text{ ft})} \right)^2 \right] + \left[4 \times \left(\frac{3 \times (15.56 \text{ ft})}{(5 \text{ ft})} + 2 \right) \times \left(\frac{(3.4068 \text{ ft})}{(5 \text{ ft})} \right)^3 \right] \right]$$

$$V_{max} = 5.032 \text{ kip}$$

M_{max} - Max bending moment located at depth $a/2$,

$$M_{max} = (H_o D L_e) \left[\left(\frac{E}{L_e} + \frac{a}{2 L_e} \right) - \left[\left(\frac{4E}{L_e} + 3 \right) \left(\frac{a}{2 L_e} \right)^3 \right] + \left[\left(\frac{3E}{L_e} + 2 \right) \left(\frac{a}{2 L_e} \right)^4 \right] \right]$$

$$M_{max} = ((-0.20382 \text{ kip/ft}) \times (48 \text{ in}) \times (5 \text{ ft})) \times \left[\left(\frac{(15.56 \text{ ft})}{(5 \text{ ft})} + \frac{(3.4068 \text{ ft})}{2 \times (5 \text{ ft})} \right) - \left[\left(\frac{4 \times (15.56 \text{ ft})}{(5 \text{ ft})} + 3 \right) \times \left(\frac{(3.4068 \text{ ft})}{2 \times (5 \text{ ft})} \right)^3 \right] + \left[\left(\frac{3 \times (15.56 \text{ ft})}{(5 \text{ ft})} + 2 \right) \times \left(\frac{(3.4068 \text{ ft})}{2 \times (5 \text{ ft})} \right)^4 \right] \right]$$

$$M_{max} = 12.207 \text{ kipft}$$

Shear force and Bending moment (z-direction, LRFD)

H_o - Lateral force per length of pile,

$$H_o = \frac{V_z}{1.57 b}$$

$$H_o = \frac{(0.159 \text{ kip})}{1.57 \times (48 \text{ in})}$$

$$H_o = 0.025318 \text{ kip/ft}$$

M_o - Moment per length of pile,

$$M_o = \frac{M_x + (V_z H)}{1.57 b}$$

$$M_o = \frac{(0.437 \text{ kipft}) + ((0.159 \text{ kip}) \times (0 \text{ ft}))}{1.57 \times (48 \text{ in})}$$

$$M_o = 0.069586 \text{ kipft/ft}$$

E - Distance from lateral load to resisting surface,

$$E = \frac{M_o}{H_o}$$

$$E = \frac{(0.069586 \text{ kipft/ft})}{(0.025318 \text{ kip/ft})}$$

$$E = 2.7484 \text{ ft}$$

a - Distance from resting surface to pivot point,

$$a = \frac{(4 M_o L_e) + (3 H_o L_e^2)}{(6 M_o) + (4 H_o L_e)}$$

$$a = \frac{(4 \times (0.069586 \text{ kipft/ft}) \times (5 \text{ ft})) + (3 \times (0.025318 \text{ kip/ft}) \times (5 \text{ ft})^2)}{(6 \times (0.069586 \text{ kipft/ft})) + (4 \times (0.025318 \text{ kip/ft}) \times (5 \text{ ft}))}$$

$$a = 3.5617 \text{ ft}$$

V_{max} - Max shear force located at depth a ,

$$V_{max} = (H_o b) \left[1 - \left[3 \left(\frac{4E}{L_e} + 3 \right) \left(\frac{a}{L_e} \right)^2 \right] + \left[4 \left(\frac{3E}{L_e} + 2 \right) \left(\frac{a}{L_e} \right)^3 \right] \right]$$

$$V_{max} = ((0.025318 \text{ kip/ft}) \times (48 \text{ in})) \times \left[1 - \left[3 \times \left(\frac{4 \times (2.7484 \text{ ft})}{(5 \text{ ft})} + 3 \right) \times \left(\frac{(3.5617 \text{ ft})}{(5 \text{ ft})} \right)^2 \right] + \left[4 \times \left(\frac{3 \times (2.7484 \text{ ft})}{(5 \text{ ft})} + 2 \right) \times \left(\frac{(3.5617 \text{ ft})}{(5 \text{ ft})} \right)^3 \right] \right]$$

$$V_{max} = 0.16589 \text{ kip}$$

M_{max} - Max bending moment located at depth $a/2$,

$$M_{max} = (H_o b L_e) \left[\left(\frac{E}{L_e} + \frac{a}{2 L_e} \right) - \left[\left(\frac{4E}{L_e} + 3 \right) \left(\frac{a}{2 L_e} \right)^3 \right] + \left[\left(\frac{3E}{L_e} + 2 \right) \left(\frac{a}{2 L_e} \right)^4 \right] \right]$$

$$M_{max} = ((0.025318 \text{ kip/ft}) \times (48 \text{ in}) \times (5 \text{ ft})) \times \left[\left(\frac{(2.7484 \text{ ft})}{(5 \text{ ft})} + \frac{(3.5617 \text{ ft})}{2 \times (5 \text{ ft})} \right) - \left[\left(\frac{4 \times (2.7484 \text{ ft})}{(5 \text{ ft})} + 3 \right) \times \left(\frac{(3.5617 \text{ ft})}{2 \times (5 \text{ ft})} \right)^3 \right] + \left[\left(\frac{3 \times (2.7484 \text{ ft})}{(5 \text{ ft})} + 2 \right) \times \left(\frac{(3.5617 \text{ ft})}{2 \times (5 \text{ ft})} \right)^4 \right] \right]$$

$$M_{max} = 0.36949 \text{ kipft}$$

Minimum Reinforcement Check (LRFD)

Parameters:

$f'_{ck} = 3 \text{ ksi}$ - Concrete strength,
 $f_{yk} = 60 \text{ ksi}$ - Longitudinal reinforcement strength,
 $\phi = 0.65$ - Reduction factor for axial strength,
 $\alpha = 0.8$ - Alpha factor for axial strength,
 $A_g = 2304 \text{ in}^2$ - Gross area of concrete,

Table 22.4.2.1

Longitudinal reinforcement:

Required reinforcement due to axial load, $A_{st,required}$

22.4.2.2, 10.6.1.1

$A_{st,required}$

$$A_{st,required} = \text{Min} \left[\frac{\frac{P}{\phi \alpha} - (0.85 f'_{ck} A_g)}{f_{yk} - (0.85 f'_{ck})}, (0.08 A_g) \right]$$

$$A_{st,required} = \text{Min} \left[\frac{\frac{(8.562 \text{ kip})}{(0.65) \times (0.8)} - (0.85 \times (3 \text{ ksi}) \times (2304 \text{ in}^2))}{(60 \text{ ksi}) - (0.85 \times (3 \text{ ksi}))}, (0.08 \times (2304 \text{ in}^2)) \right]$$

$$A_{st,required} = -101.98 \text{ in}^2$$

A_{min} - Governing minimum reinforcement area,

$$A_{min} = \text{Max} [A_{st,required}, (0.0018 A_g)]$$

$$A_{min} = \text{Max} [(-101.98 \text{ in}^2), (0.0018 \times (2304 \text{ in}^2))]$$

$$A_{min} = 4.1472 \text{ in}^2$$

n_{rebar} - Required number of reinforcement,

$$n_{rebar} = \frac{A_{min}}{A_{rebar}}$$

$$n_{rebar} = \frac{(4.1472 \text{ in}^2)}{(0.3068 \text{ in}^2)}$$

$$n_{rebar} = 14$$

A_{st} - Actual total reinforcement area,

$$A_{st} = n_{rebar} \frac{\pi d_{bar}^2}{4}$$

$$A_{st} = (14) \times \frac{\pi \times (0.625 \text{ in})^2}{4}$$

$$A_{st} = 4.2951 \text{ in}^2$$

Ratio - Capacity

$$\text{Ratio} = \frac{A_{min}}{A_{st}}$$

$$\text{Ratio} = \frac{(4.1472 \text{ in}^2)}{(4.2951 \text{ in}^2)}$$

$$\text{Ratio} = 0.96556$$

25.2.3

s_{rebar} - Minimum spacing of reinforcement,

$$s_{rebar} = \text{Max} [1.5, (1.5 d_{bar})]$$

$$s_{rebar} = \text{Max} [1.5, (1.5 \times (0.625 \text{ in}))]$$

$$s_{rebar} = 1.5 \text{ in}$$

Ties:

25.7.2.2 Since longitudinal reinforcement is \leq No. 10: Use #3(0.375 in)

25.7.2.1 s_{ties} - Maximum spacing of ties,

$$s_{ties} = \text{Min} [(16 d_{bar}), (48 d_{ties}), \text{Min} (D, b)]$$

$$s_{ties} = \text{Min} [(16 \times (0.625 \text{ in})), (48 \times (0.375 \text{ in})), \text{Min} ((48 \text{ in}), (48 \text{ in}))]$$

$$s_{ties} = 10 \text{ in}$$

Summary:

Main reinforcement: 14 - #5 (0.625 in)

Status: **PASS**
Ratio: **0.970**

Ties: #3(0.375 in) - 10 in

Axial Compression Strength (ACI 318-19, LRFD)

22.4.2.2

ϕP_N - Allowable axial compressive strength

$$\phi P_N = \phi 0.80 [(0.85 f'_{ck} [A_g - A_{st}]) + (f_{yk} A_{st})]$$

$$\phi P_N = (0.65) \times 0.80 \times [(0.85 \times (3 \text{ ksi}) \times [(2304 \text{ in}^2) - (4.2951 \text{ in}^2)]) + ((60 \text{ ksi}) \times (4.2951 \text{ in}^2))]$$

$$\phi P_N = 3183.4 \text{ kip}$$

Ratio - Capacity

$$\text{Ratio} = \frac{P}{\phi P_N}$$

$$\text{Ratio} = \frac{(8.562 \text{ kip})}{(3183.4 \text{ kip})}$$

$$\text{Ratio} = 0.0026896$$

Status: **PASS**
Ratio: **0.000**

Shear Strength (ACI 318-19, LRFD)

Parameters:

22.5.2.2

$b_w = 48 \text{ in}$ - Effective width,
 d - Effective depth

$$d = 0.80 D$$

$$d = 0.80 \times (48 \text{ in})$$

$$d = 38.4 \text{ in}$$

22.5.5.1.3

λ_s - size effect modification factor

$$\lambda_s = \text{MIN} \left[\sqrt{\frac{2}{1 + \frac{d}{10}}}, 1 \right]$$

$$\lambda_s = \text{MIN} \left[\sqrt{\frac{2}{1 + \frac{(38.4 \text{ in})}{10}}}, 1 \right]$$

$$\lambda_s = 0.64282$$

22.5.5.1.1

The following variables were converted to be consistent with empirical formula $f'_{ck} = 3 \text{ ksi} \rightarrow 3000 \text{ psi}$,
 $V_{c,max}$ - Max shear strength of concrete

$$V_{c,max} = 5 \lambda_s \sqrt{f'_{ck}} b_w d$$

$$V_{c,max} = 5 \times (0.64282) \times \sqrt{(3000 \text{ psi})} \times (48 \text{ in}) \times (38.4 \text{ in})$$

$$V_{c,max} = 324.49 \text{ kip}$$

22.5.5.1.1(a)

The following variables were converted to be consistent with empirical formula $f'_{ck} = 3 \text{ ksi} \rightarrow 3000 \text{ psi}$, $P = 8.562 \text{ kip} \rightarrow 8562 \text{ lbf}$,
 $V_{c,a}$ - Shear strength of concrete (a)

$$V_{c,a} = \left[2 \lambda_s \sqrt{f'_{ck}} + \frac{P}{6 A_g} \right] b_w d$$

$$V_{c,a} = \left[2 \times (0.64282) \times \sqrt{(3000 \text{ psi})} + \frac{(8562 \text{ lbf})}{6 \times (2304 \text{ in}^2)} \right] \times (48 \text{ in}) \times (38.4 \text{ in})$$

$$V_{c,a} = 130.94 \text{ kip}$$

22.5.5.1.2

The following variables were converted to be consistent with empirical formula $f'_{ck} = 3 \text{ ksi} \rightarrow 3000 \text{ psi}$,
 $V_{c,b}$ - Shear strength of concrete (b)

$$V_{c,b} = \left[2 \lambda_s \sqrt{f'_{ck}} + (0.05 f'_{ck}) \right] b_w d$$

$$V_{c,b} = \left[2 \times (0.64282) \times \sqrt{(3000 \text{ psi})} + (0.05 \times (3000 \text{ psi})) \right] \times (48 \text{ in}) \times (38.4 \text{ in})$$

$$V_{c,b} = 406.27 \text{ kip}$$

V_c - Governing shear strength of concrete

$$V_c = \text{Min}[V_{c,max}, V_{c,a}, V_{c,b}]$$

$$V_c = \text{Min}[(324.49 \text{ kip}), (130.94 \text{ kip}), (406.27 \text{ kip})]$$

$$V_c = 130.94 \text{ kip}$$

<p>22.5.1.2</p>	<p>The following variables were converted to be consistent with empirical formula $f'_{ck} = 3 \text{ ksi} \rightarrow 3000 \text{ psi}$, $V_{s,a}$ - Shear strength of steel (a)</p> $V_{s,a} = 8 \sqrt{f'_{ck}} b_w d$ $V_{s,a} = 8 \times \sqrt{(3000 \text{ psi})} \times (48 \text{ in}) \times (38.4 \text{ in})$ $V_{s,a} = 807.65 \text{ kip}$ <p>A_v - Ties rebar area,</p> $A_v = \frac{\pi d_{ties}^2}{4}$ $A_v = \frac{\pi \times (0.375 \text{ in})^2}{4}$ $A_v = 0.11045 \text{ in}^2$ <p>22.5.8.5.3 $V_{s,b}$ - Shear strength of steel (b)</p> $V_{s,b} = \frac{2 A_v f_{yt} d}{s_{ties}}$ $V_{s,b} = \frac{2 \times (0.11045 \text{ in}^2) \times (60 \text{ ksi}) \times (38.4 \text{ in})}{(10 \text{ in})}$ $V_{s,b} = 50.894 \text{ kip}$ <p>V_s - Governing shear strength of steel</p> $V_s = \text{MIN}[V_{s,a}, V_{s,b}]$ $V_s = \text{MIN}[(807.65 \text{ kip}), (50.894 \text{ kip})]$ $V_s = 50.894 \text{ kip}$ <p>22.5.1.1 ϕV_n - Allowable shear strength</p> $\phi V_n = \phi (V_c + V_s)$ $\phi V_n = (0.65) \times ((130.94 \text{ kip}) + (50.894 \text{ kip}))$ $\phi V_n = 118.19 \text{ kip}$ <p>Considering x-direction:</p> <p>$V_{max} = 5.032 \text{ kip}$ - Maximum shear force in the x-direction, Ratio - Capacity</p> $\text{Ratio} = \frac{V_{max}}{\phi V_n}$ $\text{Ratio} = \frac{(5.032 \text{ kip})}{(118.19 \text{ kip})}$ $\text{Ratio} = 0.042575$ <p>Considering z-direction:</p> <p>$V_{max} = 0.16589 \text{ kip}$ - Maximum shear force in the z-direction, Ratio - Capacity</p> $\text{Ratio} = \frac{V_{max}}{\phi V_n}$ $\text{Ratio} = \frac{(0.16589 \text{ kip})}{(118.19 \text{ kip})}$ $\text{Ratio} = 0.0014036$	<p>Status: PASS Ratio: 0.040</p> <p>Status: PASS Ratio: 0.000</p>
	<p>Flexural Strength (ACI 318-19, LFRD)</p> <p>S_m - Section modulus</p> $S_m = \frac{b D^2}{6}$ $S_m = \frac{(48 \text{ in}) \times (48 \text{ in})^2}{6}$ $S_m = 18432 \text{ in}^3$	

<p>14.5.2.1b</p>	<p>$\lambda = 1$ - Concrete modification factor (Normal concrete), Allowable flexural strength: M_n shall be the lesser of: $\phi M_{n,1}$</p> $\phi M_{n,1} = \phi \times 5 \times \lambda \times \sqrt{f'_c} \times S_m$ $\phi M_{n,1} = 0.65 \times 5 \times 1 \times \sqrt{3\text{ksi}} \times 18432.001\text{in}^3$ $\phi M_{n,1} = 273.423\text{kipft}$ <p>$\phi M_{n,2}$</p> $\phi M_{n,2} = \phi \times 0.85 \times f'_c \times S_m$ $\phi M_{n,2} = (0.65) \times 0.85 \times (3\text{ksi}) \times (18432\text{in}^3)$ $\phi M_{n,2} = 2545.9\text{kipft}$ <p>Therefore, ϕM_n - Allowable flexural strength,</p> $\phi M_n = \text{MIN}[\phi M_{n,1}, \phi M_{n,2}]$ $\phi M_n = \text{MIN}[(273.42\text{kipft}), (2545.9\text{kipft})]$ $\phi M_n = 273.42\text{kipft}$ <p>Considering x-direction: $M_{max} = 12.207\text{kipft}$ - Maximum moment in the x-direction, Ratio - Capacity</p> $\text{Ratio} = \frac{M_{max}}{\phi M_n}$ $\text{Ratio} = \frac{(12.207\text{kipft})}{(273.42\text{kipft})}$ $\text{Ratio} = 0.044646$	<p>Status: PASS Ratio: 0.040</p>
	<p>Considering z-direction: $M_{max} = 0.36949\text{kipft}$ - Maximum moment in the z-direction, Ratio - Capacity</p> $\text{Ratio} = \frac{M_{max}}{\phi M_n}$ $\text{Ratio} = \frac{(0.36949\text{kipft})}{(273.42\text{kipft})}$ $\text{Ratio} = 0.0013514$	<p>Status: PASS Ratio: 0.000</p>

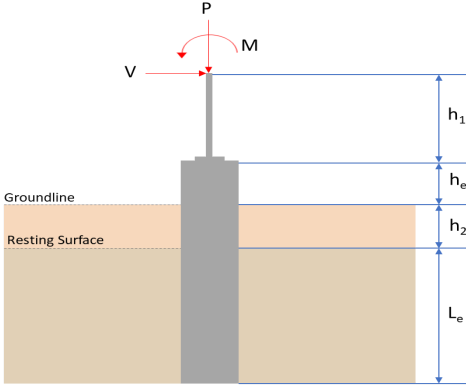
REFERENCES	CALCULATIONS	RESULTS																										
	<p>SkyCiv Foundation Design Pile Foundation</p> <p>Design Information : Design code : IBC 2021 (International Building Code) Unit System : Imperial</p>																											
	<p>Pile Input</p>  <p>Geometry Pile shape: rectangular $b = 48$ in - Pile width $D = 48$ in - Pile depth $L = 5$ ft - Total pile length $h_1 = 0$ ft - Lateral load height from the top of the pile, $h_2 = 0$ ft - Depth to resting surface $h_e = 0$ ft - Length of pile above the ground</p> <p>Tabulation of Soil Parameters</p> <table border="1" data-bbox="416 1102 1193 1191"> <thead> <tr> <th>Layer</th> <th>Label</th> <th>Allowable Bearing Pressure (q_a) (psf)</th> <th>Allowable Lateral Pressure (R) (psf/ft)</th> </tr> </thead> <tbody> <tr> <td>1</td> <td>Sand, silty sand, clayey sand, silty gravel & clayey gravel</td> <td>2000.000</td> <td>150.000</td> </tr> </tbody> </table> <p>Tabulation of Loads</p> <table border="1" data-bbox="676 1285 935 1458"> <thead> <tr> <th>Load Component</th> <th>ASD</th> <th>LRFD</th> </tr> </thead> <tbody> <tr> <td>P (kip)</td> <td>5.775</td> <td>8.562</td> </tr> <tr> <td>V_x (kip)</td> <td>-0.768</td> <td>-1.280</td> </tr> <tr> <td>V_z (kip)</td> <td>-0.106</td> <td>-0.159</td> </tr> <tr> <td>M_x (kipft)</td> <td>-0.290</td> <td>-0.437</td> </tr> <tr> <td>M_z (kipft)</td> <td>11.696</td> <td>19.918</td> </tr> </tbody> </table> <p>Material Properties $f'_{ck} = 3$ ksi - Concrete strength,</p>	Layer	Label	Allowable Bearing Pressure (q_a) (psf)	Allowable Lateral Pressure (R) (psf/ft)	1	Sand, silty sand, clayey sand, silty gravel & clayey gravel	2000.000	150.000	Load Component	ASD	LRFD	P (kip)	5.775	8.562	V_x (kip)	-0.768	-1.280	V_z (kip)	-0.106	-0.159	M_x (kipft)	-0.290	-0.437	M_z (kipft)	11.696	19.918	
Layer	Label	Allowable Bearing Pressure (q_a) (psf)	Allowable Lateral Pressure (R) (psf/ft)																									
1	Sand, silty sand, clayey sand, silty gravel & clayey gravel	2000.000	150.000																									
Load Component	ASD	LRFD																										
P (kip)	5.775	8.562																										
V_x (kip)	-0.768	-1.280																										
V_z (kip)	-0.106	-0.159																										
M_x (kipft)	-0.290	-0.437																										
M_z (kipft)	11.696	19.918																										
	<p>Required depth to resist lateral loads (ASD) H - Point of application of the lateral load</p> $H = h_1 + h_2 + h_e$ $H = (0 \text{ ft}) + (0 \text{ ft}) + (0 \text{ ft})$ $H = 0 \text{ ft}$ <p>Considering x-direction: H_o - Lateral force per length of pile,</p> $H_o = \frac{V_x}{1.57 D}$ $H_o = \frac{(-0.768 \text{ kip})}{1.57 \times (48 \text{ in})}$ $H_o = -0.12229 \text{ kip/ft}$ <p>M_o - Moment per length of pile,</p> $M_o = \frac{M_z + (V_x H)}{1.57 D}$																											

$$M_o = \frac{(11.696 \text{ kipft}) + ((-0.768 \text{ kip}) \times (0 \text{ ft}))}{1.57 \times (48 \text{ in})}$$

$$M_o = 1.8624 \text{ kipft/ft}$$

Required depth of embedment in earth:

$$L_x^3 - \left(14.14 \times \frac{H_o \times L_x}{R}\right) - \left(18.85 \times \frac{M_o}{R}\right) = 0$$

Solving the cubic equation:

$L_{e,x} = 4.8413 \text{ ft}$ - Required depth in x-direction,

Considering z-direction:

H_o - Lateral force per length of pile,

$$H_o = \frac{V_z}{1.57 b}$$

$$H_o = \frac{(-0.106 \text{ kip})}{1.57 \times (48 \text{ in})}$$

$$H_o = -0.016879 \text{ kip/ft}$$

M_o - Moment per length of pile,

$$M_o = \frac{M_x + (V_z H)}{1.57 b}$$

$$M_o = \frac{(0.29 \text{ kipft}) + ((-0.106 \text{ kip}) \times (0 \text{ ft}))}{1.57 \times (48 \text{ in})}$$

$$M_o = 0.046178 \text{ kipft/ft}$$

Required depth of embedment in earth:

$$L_z^3 - \left(14.14 \times \frac{H_o \times L_z}{R}\right) - \left(18.85 \times \frac{M_o}{R}\right) = 0$$

Solving the cubic equation:

$L_{e,z} = 1.3292 \text{ ft}$ - Required depth in z-direction,

Minimum embedded depth required:

$L_{e,req}$ - Depth of pile required,

$$L_{e,req} = \text{MAX}[L_{e,x}, L_{e,z}]$$

$$L_{e,req} = \text{MAX}[(4.8413 \text{ ft}), (1.3292 \text{ ft})]$$

$$L_{e,req} = 4.841 \text{ ft}$$

L_e - Actual embedded length of pile,

$$L_e = L - h_c - h_2$$

$$L_e = (5 \text{ ft}) - (0 \text{ ft}) - (0 \text{ ft})$$

$$L_e = 5 \text{ ft}$$

Ratio - Embedded depth

$$\text{Ratio} = \frac{L_{e,req}}{L_e}$$

$$\text{Ratio} = \frac{(4.841 \text{ ft})}{(5 \text{ ft})}$$

$$\text{Ratio} = 0.9682$$

Status: **PASS**
Ratio: **0.970**

End-bearing Capacity (ASD)

A - Pile cross-section area

$$A = b D$$

$$A = (48 \text{ in}) \times (48 \text{ in})$$

$$A = 16 \text{ ft}^2$$

q - End-bearing pressure

$$q = \frac{P_c}{A}$$

$$q = \frac{(5.775 \text{ kip})}{(16 \text{ ft}^2)}$$

$$q = 0.36094 \text{ kip/ft}^2$$

$$q = 0.00094 \text{ kip/ft}$$

Check bearing capacity ratio:

Ratio - Capacity

$$\text{Ratio} = \frac{q}{q_a}$$

$$\text{Ratio} = \frac{(0.36094 \text{ kip/ft}^2)}{(2000 \text{ psf})}$$

$$\text{Ratio} = 0.18047$$

Status: **PASS**
Ratio: **0.180**

Czerniak

Lateral Soil Pressure (ASD):

L/D - Length to least lateral dimension ratio,

$$L/D = \frac{L}{D}$$

$$L/D = \frac{(5 \text{ ft})}{(48 \text{ in})}$$

$$L/D = 1.25$$

Since $L/D \leq 10$,

Pile is short.

Considering x-direction:

$H_o = -0.12229 \text{ kip/ft}$ - Lateral force per length of pile,

$M_o = 1.8624 \text{ kipft/ft}$ - Overturning moment per length of pile,

a - Distance from resting surface to pivot point,

$$a = \frac{(4 M_o L_e) + (3 H_o L_e^2)}{(6 M_o) + (4 H_o L_e)}$$

$$a = \frac{(4 \times (1.8624 \text{ kipft/ft}) \times (5 \text{ ft})) + (3 \times (-0.12229 \text{ kip/ft}) \times (5 \text{ ft})^2)}{(6 \times (1.8624 \text{ kipft/ft})) + (4 \times (-0.12229 \text{ kip/ft}) \times (5 \text{ ft}))}$$

$$a = 3.4082 \text{ ft}$$

p - Earth pressure against the pile at distance $a/2$ from resting surface,

$$p = \frac{0.75 [(4 M_o) + (3 H_o L_e)]^2}{L_e^2 [(3 M_o) + (2 H_o L_e)]}$$

$$p = \frac{0.75 \times [(4 \times (1.8624 \text{ kipft/ft})) + (3 \times (-0.12229 \text{ kip/ft}) \times (5 \text{ ft}))]^2}{(5 \text{ ft})^2 \times [(3 \times (1.8624 \text{ kipft/ft})) + (2 \times (-0.12229 \text{ kip/ft}) \times (5 \text{ ft}))]}$$

$$p = 0.21674 \text{ kip/ft}^2$$

s - Earth pressure against the pile at distance L_e ,

$$s = \frac{6 [(2 M_o) + (H_o L_e)]}{L_e^2}$$

$$s = \frac{6 \times [(2 \times (1.8624 \text{ kipft/ft})) + ((-0.12229 \text{ kip/ft}) \times (5 \text{ ft}))]}{(5 \text{ ft})^2}$$

$$s = 0.74721 \text{ kip/ft}^2$$

Check lateral soil pressure capacity:

p_a - Allowable lateral soil pressure at depth $a/2$,

$$p_a = R \frac{a}{2}$$

$$p_a = (150 \text{ psf/ft}) \times \frac{(3.4082 \text{ ft})}{2}$$

$$p_a = 0.25561 \text{ kip/ft}^2$$

Ratio - Lateral soil capacity

$$\text{Ratio} = \frac{p}{p_a}$$

$$\text{Ratio} = \frac{(0.21674 \text{ kip/ft}^2)}{(0.25561 \text{ kip/ft}^2)}$$

$$\text{Ratio} = 0.84794$$

p_a - Allowable lateral soil pressure at depth L_e ,

Status: **PASS**
Ratio: **0.850**

	$p_s = R L_e$ $p_s = (150 \text{ psf/ft}) \times (5 \text{ ft})$ $p_s = 0.75 \text{ kip/ft}^2$ <p>Ratio - Lateral soil capacity</p> $\text{Ratio} = \frac{s}{p_s}$ $\text{Ratio} = \frac{(0.74721 \text{ kip/ft}^2)}{(0.75 \text{ kip/ft}^2)}$ $\text{Ratio} = 0.99628$	<p>Status: PASS Ratio: 1.000</p>
	<p>Considering z-direction:</p> <p>$H_o = -0.016879 \text{ kip/ft}$ - Lateral force per length of pile, $M_o = 0.046178 \text{ kipft/ft}$ - Overturning moment per length of pile, a - Distance from resting surface to pivot point,</p> $a = \frac{(4 M_o L_e) + (3 H_o L_e^2)}{(6 M_o) + (4 H_o L_e)}$ $a = \frac{(4 \times (0.046178 \text{ kipft/ft}) \times (5 \text{ ft})) + (3 \times (-0.016879 \text{ kip/ft}) \times (5 \text{ ft})^2)}{(6 \times (0.046178 \text{ kipft/ft})) + (4 \times (-0.016879 \text{ kip/ft}) \times (5 \text{ ft}))}$ $a = 3.5622 \text{ ft}$ <p>p - Earth pressure against the pile at distance $a/2$ from resting surface,</p> $p = \frac{0.75 [(4 M_o) + (3 H_o L_e)]^2}{L_e^2 [(3 M_o) + (2 H_o L_e)]}$ $p = \frac{0.75 \times [(4 \times (0.046178 \text{ kipft/ft})) + (3 \times (-0.016879 \text{ kip/ft}) \times (5 \text{ ft}))]^2}{(5 \text{ ft})^2 \times [(3 \times (0.046178 \text{ kipft/ft})) + (2 \times (-0.016879 \text{ kip/ft}) \times (5 \text{ ft}))]}$ $p = -0.0046488 \text{ kip/ft}^2$ <p>s - Earth pressure against the pile at distance L_e,</p> $s = \frac{6 [(2 M_o) + (H_o L_e)]}{L_e^2}$ $s = \frac{6 \times [(2 \times (0.046178 \text{ kipft/ft})) + ((-0.016879 \text{ kip/ft}) \times (5 \text{ ft}))]}{(5 \text{ ft})^2}$ $s = 0.0019108 \text{ kip/ft}^2$ <p>Check lateral soil pressure capacity:</p> <p>p_a - Allowable lateral soil pressure at depth $a/2$,</p> $p_a = R \frac{a}{2}$ $p_a = (150 \text{ psf/ft}) \times \frac{(3.5622 \text{ ft})}{2}$ $p_a = 0.26716 \text{ kip/ft}^2$ <p>Ratio - Lateral soil capacity</p> $\text{Ratio} = \frac{p}{p_a}$ $\text{Ratio} = \frac{(-0.0046488 \text{ kip/ft}^2)}{(0.26716 \text{ kip/ft}^2)}$ $\text{Ratio} = -0.017401$ <p>p_s - Allowable lateral soil pressure at depth L_e,</p> $p_s = R L_e$ $p_s = (150 \text{ psf/ft}) \times (5 \text{ ft})$ $p_s = 0.75 \text{ kip/ft}^2$ <p>Ratio - Lateral soil capacity</p> $\text{Ratio} = \frac{s}{p_s}$	<p>Status: PASS Ratio: -0.020</p>

$$Ratio = \frac{(0.0019108 \text{ kip/ft}^2)}{(0.75 \text{ kip/ft}^2)}$$

$$Ratio = 0.0025478$$

Status: **PASS**
Ratio: **0.000**

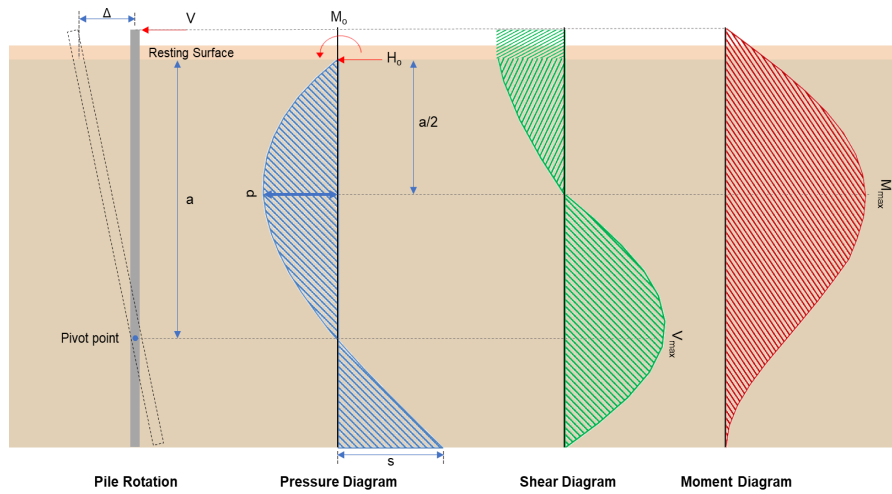

Shear force and Bending moment (x-direction, LRF)

H_o - Lateral force per length of pile,

$$H_o = \frac{V_e}{1.57 D}$$

$$H_o = \frac{(-1.28 \text{ kip})}{1.57 \times (48 \text{ in})}$$

$$H_o = -0.20382 \text{ kip/ft}$$

M_o - Moment per length of pile,

$$M_o = \frac{M_z + (V_x H)}{1.57 D}$$

$$M_o = \frac{(19.918 \text{ kipft}) + ((-1.28 \text{ kip}) \times (0 \text{ ft}))}{1.57 \times (48 \text{ in})}$$

$$M_o = 3.1717 \text{ kipft/ft}$$

E - Distance from lateral load to resisting surface,

$$E = \frac{M_o}{H_o}$$

$$E = \frac{(3.1717 \text{ kipft/ft})}{(-0.20382 \text{ kip/ft})}$$

$$E = 15.561 \text{ ft}$$

a - Distance from resting surface to pivot point,

$$a = \frac{(4 M_o L_e) + (3 H_o L_e^2)}{(6 M_o) + (4 H_o L_e)}$$

$$a = \frac{(4 \times (3.1717 \text{ kipft/ft}) \times (5 \text{ ft})) + (3 \times (-0.20382 \text{ kip/ft}) \times (5 \text{ ft})^2)}{(6 \times (3.1717 \text{ kipft/ft})) + (4 \times (-0.20382 \text{ kip/ft}) \times (5 \text{ ft}))}$$

$$a = 3.4068 \text{ ft}$$

V_{max} - Max shear force located at depth a ,

$$V_{max} = (H_o D) \left[1 - \left[3 \left(\frac{4 E}{L_e} + 3 \right) \left(\frac{a}{L_e} \right)^2 \right] + \left[4 \left(\frac{3 E}{L_e} + 2 \right) \left(\frac{a}{L_e} \right)^3 \right] \right]$$

$$V_{max} = ((-0.20382 \text{ kip/ft}) \times (48 \text{ in})) \times \left[1 - \left[3 \times \left(\frac{4 \times (15.561 \text{ ft})}{(5 \text{ ft})} + 3 \right) \times \left(\frac{(3.4068 \text{ ft})}{(5 \text{ ft})} \right)^2 \right] + \left[4 \times \left(\frac{3 \times (15.561 \text{ ft})}{(5 \text{ ft})} + 2 \right) \times \left(\frac{(3.4068 \text{ ft})}{(5 \text{ ft})} \right)^3 \right] \right]$$

$$V_{max} = 5.0322 \text{ kip}$$

M_{max} - Max bending moment located at depth $a/2$,

$$M_{max} = (H_o D L_e) \left[\left(\frac{E}{L_e} + \frac{a}{2 L_e} \right) - \left[\left(\frac{4 E}{L_e} + 3 \right) \left(\frac{a}{2 L_e} \right)^3 \right] + \left[\left(\frac{3 E}{L_e} + 2 \right) \left(\frac{a}{2 L_e} \right)^4 \right] \right]$$

$$M_{max} = ((-0.20382 \text{ kip/ft}) \times (48 \text{ in}) \times (5 \text{ ft})) \times \left[\left(\frac{(15.561 \text{ ft})}{(5 \text{ ft})} + \frac{(3.4068 \text{ ft})}{2 \times (5 \text{ ft})} \right) - \left[\left(\frac{4 \times (15.561 \text{ ft})}{(5 \text{ ft})} + 3 \right) \times \left(\frac{(3.4068 \text{ ft})}{2 \times (5 \text{ ft})} \right)^3 \right] + \left[\left(\frac{3 \times (15.561 \text{ ft})}{(5 \text{ ft})} + 2 \right) \times \left(\frac{(3.4068 \text{ ft})}{2 \times (5 \text{ ft})} \right)^4 \right] \right]$$

$$M_{max} = 12.208 \text{ kipft}$$

Shear force and Bending moment (z-direction, LRFD)

H_o - Lateral force per length of pile,

$$H_o = \frac{V_z}{1.57 b}$$

$$H_o = \frac{(-0.159 \text{ kip})}{1.57 \times (48 \text{ in})}$$

$$H_o = -0.025318 \text{ kip/ft}$$

M_o - Moment per length of pile,

$$M_o = \frac{M_x + (V_z H)}{1.57 b}$$

$$M_o = \frac{(0.437 \text{ kipft}) + ((-0.159 \text{ kip}) \times (0 \text{ ft}))}{1.57 \times (48 \text{ in})}$$

$$M_o = 0.069586 \text{ kipft/ft}$$

E - Distance from lateral load to resisting surface,

$$E = \frac{M_o}{H_o}$$

$$E = \frac{(0.069586 \text{ kipft/ft})}{(-0.025318 \text{ kip/ft})}$$

$$E = 2.7484 \text{ ft}$$

a - Distance from resting surface to pivot point,

$$a = \frac{(4 M_o L_e) + (3 H_o L_e^2)}{(6 M_o) + (4 H_o L_e)}$$

$$a = \frac{(4 \times (0.069586 \text{ kipft/ft}) \times (5 \text{ ft})) + (3 \times (-0.025318 \text{ kip/ft}) \times (5 \text{ ft})^2)}{(6 \times (0.069586 \text{ kipft/ft})) + (4 \times (-0.025318 \text{ kip/ft}) \times (5 \text{ ft}))}$$

$$a = 3.5617 \text{ ft}$$

V_{max} - Max shear force located at depth a ,

$$V_{max} = (H_o b) \left[1 - \left[3 \left(\frac{4 E}{L_e} + 3 \right) \left(\frac{a}{L_e} \right)^2 \right] + \left[4 \left(\frac{3 E}{L_e} + 2 \right) \left(\frac{a}{L_e} \right)^3 \right] \right]$$

$$V_{max} = ((-0.025318 \text{ kip/ft}) \times (48 \text{ in})) \times \left[1 - \left[3 \times \left(\frac{4 \times (2.7484 \text{ ft})}{(5 \text{ ft})} + 3 \right) \times \left(\frac{(3.5617 \text{ ft})}{(5 \text{ ft})} \right)^2 \right] + \left[4 \times \left(\frac{3 \times (2.7484 \text{ ft})}{(5 \text{ ft})} + 2 \right) \times \left(\frac{(3.5617 \text{ ft})}{(5 \text{ ft})} \right)^3 \right] \right]$$

$$V_{max} = 0.16589 \text{ kip}$$

M_{max} - Max bending moment located at depth $a/2$,

$$M_{max} = (H_o b L_e) \left[\left(\frac{E}{L_e} + \frac{a}{2 L_e} \right) - \left[\left(\frac{4 E}{L_e} + 3 \right) \left(\frac{a}{2 L_e} \right)^3 \right] + \left[\left(\frac{3 E}{L_e} + 2 \right) \left(\frac{a}{2 L_e} \right)^4 \right] \right]$$

$$M_{max} = ((-0.025318 \text{ kip/ft}) \times (48 \text{ in}) \times (5 \text{ ft})) \times \left[\left(\frac{(2.7484 \text{ ft})}{(5 \text{ ft})} + \frac{(3.5617 \text{ ft})}{2 \times (5 \text{ ft})} \right) - \left[\left(\frac{4 \times (2.7484 \text{ ft})}{(5 \text{ ft})} + 3 \right) \times \left(\frac{(3.5617 \text{ ft})}{2 \times (5 \text{ ft})} \right)^3 \right] + \left[\left(\frac{3 \times (2.7484 \text{ ft})}{(5 \text{ ft})} + 2 \right) \times \left(\frac{(3.5617 \text{ ft})}{2 \times (5 \text{ ft})} \right)^4 \right] \right]$$

$$M_{max} = 0.36949 \text{ kipft}$$

Minimum Reinforcement Check (LRFD)

Parameters:

$f'_{ck} = 3 \text{ ksi}$ - Concrete strength,
 $f_{yk} = 60 \text{ ksi}$ - Longitudinal reinforcement strength,
 $\phi = 0.65$ - Reduction factor for axial strength,
 $\alpha = 0.8$ - Alpha factor for axial strength,
 $A_g = 2304 \text{ in}^2$ - Gross area of concrete,

Table 22.4.2.1

Longitudinal reinforcement:

Required reinforcement due to axial load, $A_{st,required}$

22.4.2.2, 10.6.1.1

$A_{st,required}$

$$A_{st,required} = \text{Min} \left[\frac{\frac{P}{\phi \alpha} - (0.85 f'_{ck} A_g)}{f_{yk} - (0.85 f'_{ck})}, (0.08 A_g) \right]$$

$$A_{st,required} = \text{Min} \left[\frac{\frac{(8.562 \text{ kip})}{(0.65) \times (0.8)} - (0.85 \times (3 \text{ ksi}) \times (2304 \text{ in}^2))}{(60 \text{ ksi}) - (0.85 \times (3 \text{ ksi}))}, (0.08 \times (2304 \text{ in}^2)) \right]$$

$$A_{st,required} = -101.98 \text{ in}^2$$

A_{min} - Governing minimum reinforcement area,

$$A_{min} = \text{Max} [A_{st,required}, (0.0018 A_g)]$$

$$A_{min} = \text{Max} [(-101.98 \text{ in}^2), (0.0018 \times (2304 \text{ in}^2))]$$

$$A_{min} = 4.1472 \text{ in}^2$$

n_{rebar} - Required number of reinforcement,

$$n_{rebar} = \frac{A_{min}}{A_{rebar}}$$

$$n_{rebar} = \frac{(4.1472 \text{ in}^2)}{(0.3068 \text{ in}^2)}$$

$$n_{rebar} = 14$$

A_{st} - Actual total reinforcement area,

$$A_{st} = n_{rebar} \frac{\pi d_{bar}^2}{4}$$

$$A_{st} = (14) \times \frac{\pi \times (0.625 \text{ in})^2}{4}$$

$$A_{st} = 4.2951 \text{ in}^2$$

Ratio - Capacity

$$\text{Ratio} = \frac{A_{min}}{A_{st}}$$

$$\text{Ratio} = \frac{(4.1472 \text{ in}^2)}{(4.2951 \text{ in}^2)}$$

$$\text{Ratio} = 0.96556$$

25.2.3

s_{rebar} - Minimum spacing of reinforcement,

$$s_{rebar} = \text{Max} [1.5, (1.5 d_{bar})]$$

$$s_{rebar} = \text{Max} [1.5, (1.5 \times (0.625 \text{ in}))]$$

$$s_{rebar} = 1.5 \text{ in}$$

Ties:

25.7.2.2 Since longitudinal reinforcement is \leq No. 10: Use #3(0.375 in)

25.7.2.1 s_{ties} - Maximum spacing of ties,

$$s_{ties} = \text{Min} [(16 d_{bar}), (48 d_{ties}), \text{Min} (D, b)]$$

$$s_{ties} = \text{Min} [(16 \times (0.625 \text{ in})), (48 \times (0.375 \text{ in})), \text{Min} ((48 \text{ in}), (48 \text{ in}))]$$

$$s_{ties} = 10 \text{ in}$$

Summary:

Main reinforcement: 14 - #5 (0.625 in)

Status: **PASS**
Ratio: **0.970**

Ties: #3(0.375 in) - 10 in

Axial Compression Strength (ACI 318-19, LRFD)

22.4.2.2

ϕP_N - Allowable axial compressive strength

$$\phi P_N = \phi 0.80 [(0.85 f'_{ck} [A_g - A_{st}]) + (f_{yk} A_{st})]$$

$$\phi P_N = (0.65) \times 0.80 \times [(0.85 \times (3 \text{ ksi}) \times [(2304 \text{ in}^2) - (4.2951 \text{ in}^2)]) + ((60 \text{ ksi}) \times (4.2951 \text{ in}^2))]$$

$$\phi P_N = 3183.4 \text{ kip}$$

Ratio - Capacity

$$\text{Ratio} = \frac{P}{\phi P_N}$$

$$\text{Ratio} = \frac{(8.562 \text{ kip})}{(3183.4 \text{ kip})}$$

$$\text{Ratio} = 0.0026896$$

Status: **PASS**
Ratio: **0.000**

Shear Strength (ACI 318-19, LRFD)

Parameters:

22.5.2.2

$b_w = 48 \text{ in}$ - Effective width,
 d - Effective depth

$$d = 0.80 D$$

$$d = 0.80 \times (48 \text{ in})$$

$$d = 38.4 \text{ in}$$

22.5.5.1.3

λ_s - size effect modification factor

$$\lambda_s = \text{MIN} \left[\sqrt{\frac{2}{1 + \frac{d}{10}}}, 1 \right]$$

$$\lambda_s = \text{MIN} \left[\sqrt{\frac{2}{1 + \frac{(38.4 \text{ in})}{10}}}, 1 \right]$$

$$\lambda_s = 0.64282$$

22.5.5.1.1

The following variables were converted to be consistent with empirical formula $f'_{ck} = 3 \text{ ksi} \rightarrow 3000 \text{ psi}$,
 $V_{c,max}$ - Max shear strength of concrete

$$V_{c,max} = 5 \lambda_s \sqrt{f'_{ck}} b_w d$$

$$V_{c,max} = 5 \times (0.64282) \times \sqrt{(3000 \text{ psi})} \times (48 \text{ in}) \times (38.4 \text{ in})$$

$$V_{c,max} = 324.49 \text{ kip}$$

22.5.5.1.1(a)

The following variables were converted to be consistent with empirical formula $f'_{ck} = 3 \text{ ksi} \rightarrow 3000 \text{ psi}$, $P = 8.562 \text{ kip} \rightarrow 8562 \text{ lbf}$,
 $V_{c,a}$ - Shear strength of concrete (a)

$$V_{c,a} = \left[2 \lambda_s \sqrt{f'_{ck}} + \frac{P}{6 A_g} \right] b_w d$$

$$V_{c,a} = \left[2 \times (0.64282) \times \sqrt{(3000 \text{ psi})} + \frac{(8562 \text{ lbf})}{6 \times (2304 \text{ in}^2)} \right] \times (48 \text{ in}) \times (38.4 \text{ in})$$

$$V_{c,a} = 130.94 \text{ kip}$$

22.5.5.1.2

The following variables were converted to be consistent with empirical formula $f'_{ck} = 3 \text{ ksi} \rightarrow 3000 \text{ psi}$,
 $V_{c,b}$ - Shear strength of concrete (b)

$$V_{c,b} = \left[2 \lambda_s \sqrt{f'_{ck}} + (0.05 f'_{ck}) \right] b_w d$$

$$V_{c,b} = \left[2 \times (0.64282) \times \sqrt{(3000 \text{ psi})} + (0.05 \times (3000 \text{ psi})) \right] \times (48 \text{ in}) \times (38.4 \text{ in})$$

$$V_{c,b} = 406.27 \text{ kip}$$

V_c - Governing shear strength of concrete

$$V_c = \text{Min}[V_{c,max}, V_{c,a}, V_{c,b}]$$

$$V_c = \text{Min}[(324.49 \text{ kip}), (130.94 \text{ kip}), (406.27 \text{ kip})]$$

$$V_c = 130.94 \text{ kip}$$

<p>22.5.1.2</p>	<p>The following variables were converted to be consistent with empirical formula $f'_{ck} = 3 \text{ ksi} \rightarrow 3000 \text{ psi}$, $V_{s,a}$ - Shear strength of steel (a)</p> $V_{s,a} = 8 \sqrt{f'_{ck}} b_w d$ $V_{s,a} = 8 \times \sqrt{(3000 \text{ psi})} \times (48 \text{ in}) \times (38.4 \text{ in})$ $V_{s,a} = 807.65 \text{ kip}$ <p>A_v - Ties rebar area,</p> $A_v = \frac{\pi d_{ties}^2}{4}$ $A_v = \frac{\pi \times (0.375 \text{ in})^2}{4}$ $A_v = 0.11045 \text{ in}^2$ <p>22.5.8.5.3 $V_{s,b}$ - Shear strength of steel (b)</p> $V_{s,b} = \frac{2 A_v f_{yt} d}{s_{ties}}$ $V_{s,b} = \frac{2 \times (0.11045 \text{ in}^2) \times (60 \text{ ksi}) \times (38.4 \text{ in})}{(10 \text{ in})}$ $V_{s,b} = 50.894 \text{ kip}$ <p>V_s - Governing shear strength of steel</p> $V_s = \text{MIN}[V_{s,a}, V_{s,b}]$ $V_s = \text{MIN}[(807.65 \text{ kip}), (50.894 \text{ kip})]$ $V_s = 50.894 \text{ kip}$ <p>22.5.1.1 ϕV_n - Allowable shear strength</p> $\phi V_n = \phi (V_c + V_s)$ $\phi V_n = (0.65) \times ((130.94 \text{ kip}) + (50.894 \text{ kip}))$ $\phi V_n = 118.19 \text{ kip}$ <p>Considering x-direction:</p> <p>$V_{max} = 5.0322 \text{ kip}$ - Maximum shear force in the x-direction, Ratio - Capacity</p> $\text{Ratio} = \frac{V_{max}}{\phi V_n}$ $\text{Ratio} = \frac{(5.0322 \text{ kip})}{(118.19 \text{ kip})}$ $\text{Ratio} = 0.042577$ <p>Considering z-direction:</p> <p>$V_{max} = 0.16589 \text{ kip}$ - Maximum shear force in the z-direction, Ratio - Capacity</p> $\text{Ratio} = \frac{V_{max}}{\phi V_n}$ $\text{Ratio} = \frac{(0.16589 \text{ kip})}{(118.19 \text{ kip})}$ $\text{Ratio} = 0.0014036$	<p>Status: PASS Ratio: 0.040</p> <p>Status: PASS Ratio: 0.000</p>
	<p>Flexural Strength (ACI 318-19, LFRD)</p> <p>S_m - Section modulus</p> $S_m = \frac{b D^2}{6}$ $S_m = \frac{(48 \text{ in}) \times (48 \text{ in})^2}{6}$ $S_m = 18432 \text{ in}^3$	

<p>14.5.2.1b</p>	<p>$\lambda = 1$ - Concrete modification factor (Normal concrete), Allowable flexural strength: M_n shall be the lesser of: $\phi M_{n,1}$</p> $\phi M_{n,1} = \phi \times 5 \times \lambda \times \sqrt{f'_c} \times S_m$ $\phi M_{n,1} = 0.65 \times 5 \times 1 \times \sqrt{3\text{ksi}} \times 18432.001\text{in}^3$ $\phi M_{n,1} = 273.423\text{kipft}$ <p>$\phi M_{n,2}$</p> $\phi M_{n,2} = \phi \times 0.85 \times f'_c \times S_m$ $\phi M_{n,2} = (0.65) \times 0.85 \times (3\text{ksi}) \times (18432\text{in}^3)$ $\phi M_{n,2} = 2545.9\text{kipft}$ <p>Therefore, ϕM_n - Allowable flexural strength,</p> $\phi M_n = \text{MIN}[\phi M_{n,1}, \phi M_{n,2}]$ $\phi M_n = \text{MIN}[(273.42\text{kipft}), (2545.9\text{kipft})]$ $\phi M_n = 273.42\text{kipft}$ <p>Considering x-direction: $M_{max} = 12.208\text{kipft}$ - Maximum moment in the x-direction, Ratio - Capacity</p> $\text{Ratio} = \frac{M_{max}}{\phi M_n}$ $\text{Ratio} = \frac{(12.208\text{kipft})}{(273.42\text{kipft})}$ $\text{Ratio} = 0.044648$	<p>Status: PASS Ratio: 0.040</p>
	<p>Considering z-direction: $M_{max} = 0.36949\text{kipft}$ - Maximum moment in the z-direction, Ratio - Capacity</p> $\text{Ratio} = \frac{M_{max}}{\phi M_n}$ $\text{Ratio} = \frac{(0.36949\text{kipft})}{(273.42\text{kipft})}$ $\text{Ratio} = 0.0013514$	<p>Status: PASS Ratio: 0.000</p>