

Your Project Calculations



Project Name: Tester

S3D Model Link:

https://platform.skyciv.com/structural?preload_name=Tester&preload_path=Shared%20Enterprise%20Folder/MT_Solar_Projects/3_2023

Public Model Link:

https://platform.skyciv.com/structural-viewer?project_id=JyuBzARzRLagtfSTL62YElaRw4uPitLW3bGBG3N8fEQjxl4qd6pYdUeFCIvkNbD

Array Specification

Product:	Beam
Unique ID:	1P-0-8TOP-HD-57-L-5Hx3W-AJC9
Duty Classification:	HD
Module Width:	41.10 in
Module Length:	74.00in
Number of Rows:	5
Number of Columns:	3
Total Number of Modules:	15
Desired Tilt Angle:	40
Front Edge Clearance:	5
Total Array Height at Tilt:	16.07 ft
Total Frame Length:	17.00 ft
Frame Weight:	1013 lbs
Array Dimensions N/S:	17.33 ft
Array Dimensions E/W:	18.75 ft
Rail Length:	208.00 in
Rail Spacing:	3.08 ft
Rail Check:	Not Checked

Support Specifications

Pole Size:	8in Pipe Sch 80
Pole Length above Grade:	10.57 ft
Number of Poles:	1
Pole Spacing:	0

Foundation Specifications

Foundation Type:	Square
Foundation Dimensions:	48 x 48 in
Foundation Depth (below grade):	Pile 1: 7.50 ft
Foundation Volume:	4.444 y ³
Foundation Result:	PASSED

Site Info

Risk Category:	I
Exposure:	C
Soil Classification:	sand
Site Location:	280 Main St, Lander, WY 82520, USA
Wind Speed:	110 mph
Snow Load:	50 psf
Design Uplift Pressure:	Multiple pressures
Design Downforce Pressure:	Multiple pressures
Design Snow Pressure:	0.012636 ksf

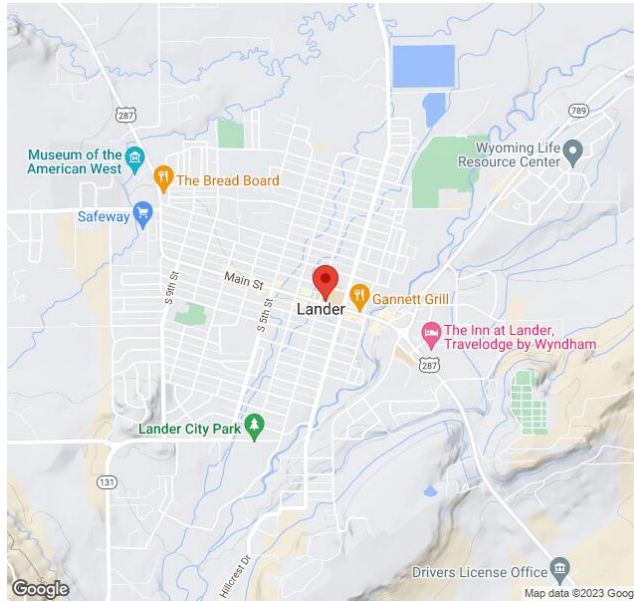

Design Disclaimer

This software should be used for preliminary designs and should not be used as a final design unless reviewed, verified and designed by a qualified structural engineer.

AutoDesigner Input

```
{
  "product_type": "Beam",
  "project_id": "Tester",
  "site_address": "280 Main St, Lander, WY 82520, USA",
  "module_width": 41.1,
  "module_length": 74,
  "number_rows": 5,
  "number_columns": 3,
  "pole_mount_section": "4_40",
  "core_pipe_width": 65,
  "core_pipe_section": "2_40",
  "adjuster_section": "2_40",
  "core_beam_height": 65,
  "core_beam_section": "HSS3x2x1/8",
  "main_pipe_section": "2_12GA",
  "pole_spacing": 15,
  "tilt_angle": 40,
  "ground_clearance": 5,
  "risk_category": "I",
  "exposure_category": "C",
  "frame_duty_override": "auto",
  "pole_override": "auto",
  "soil_type": "sand",
  "foundation_type": "Square",
  "foundation_size": 48,
  "check_rails": false,
  "wind_speed_override": 110,
  "snow_load_override": 50,
  "direct_snow_load": false
}
```

Design Notes:

- AISC Deflection checks are set to L/1 due to structure design intent
- Foundation Design and Sizing is approximate only

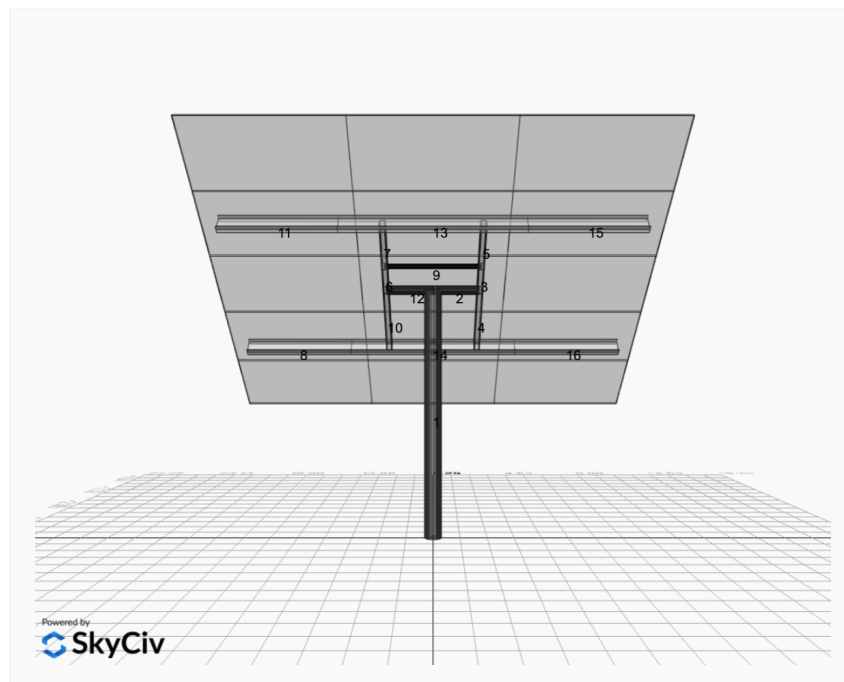

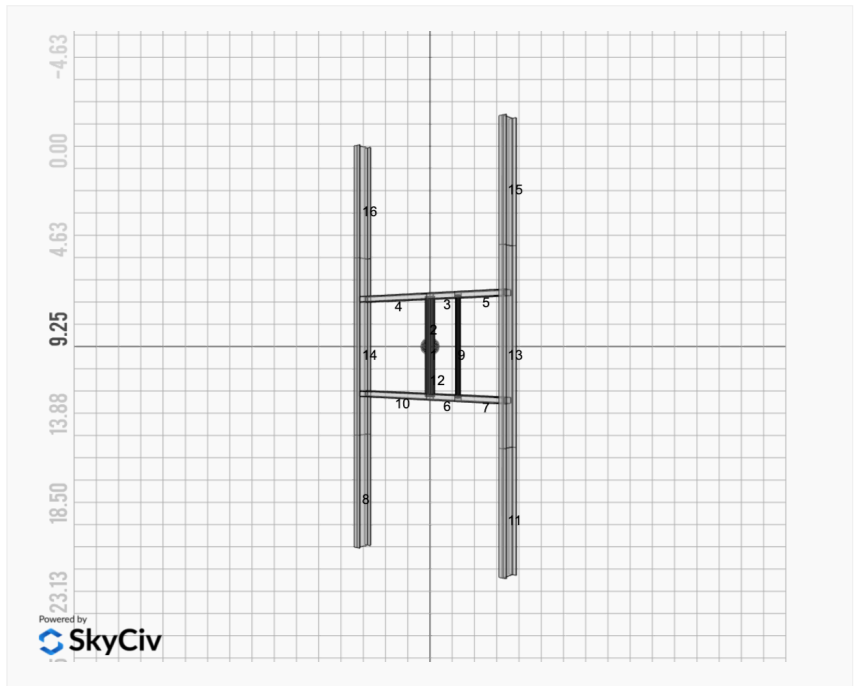
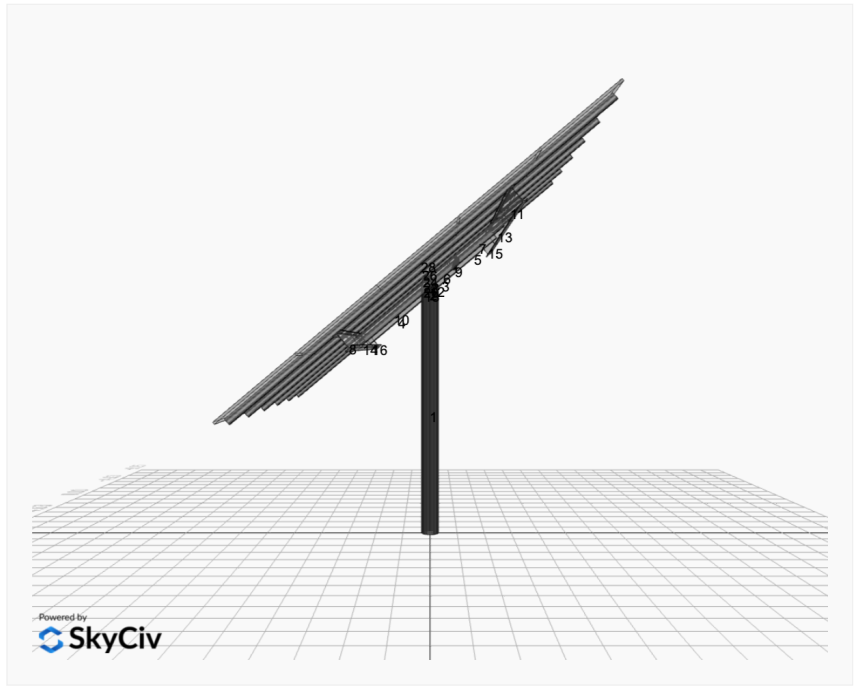

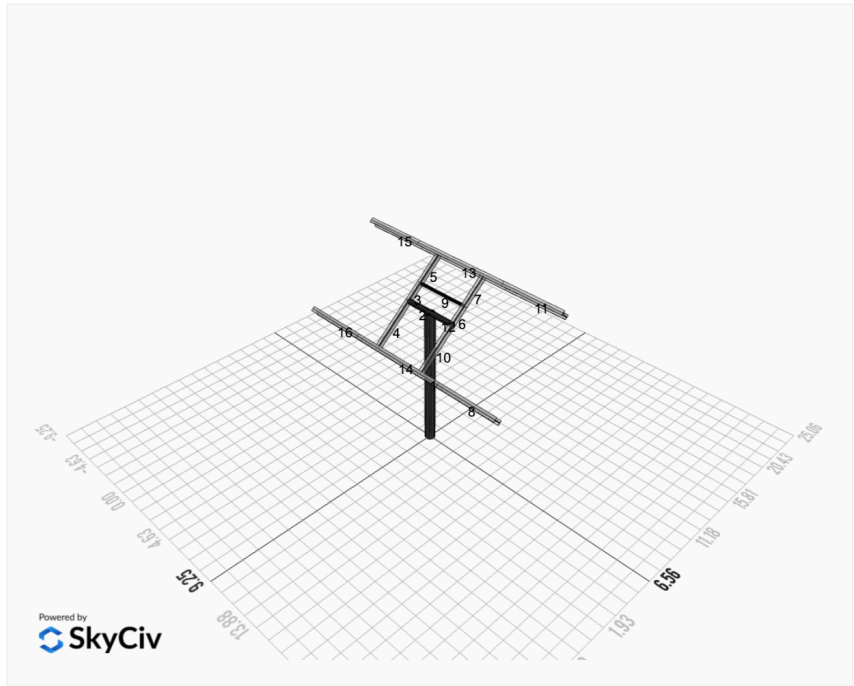

FEM Results (Envelope Worst Case for each member)

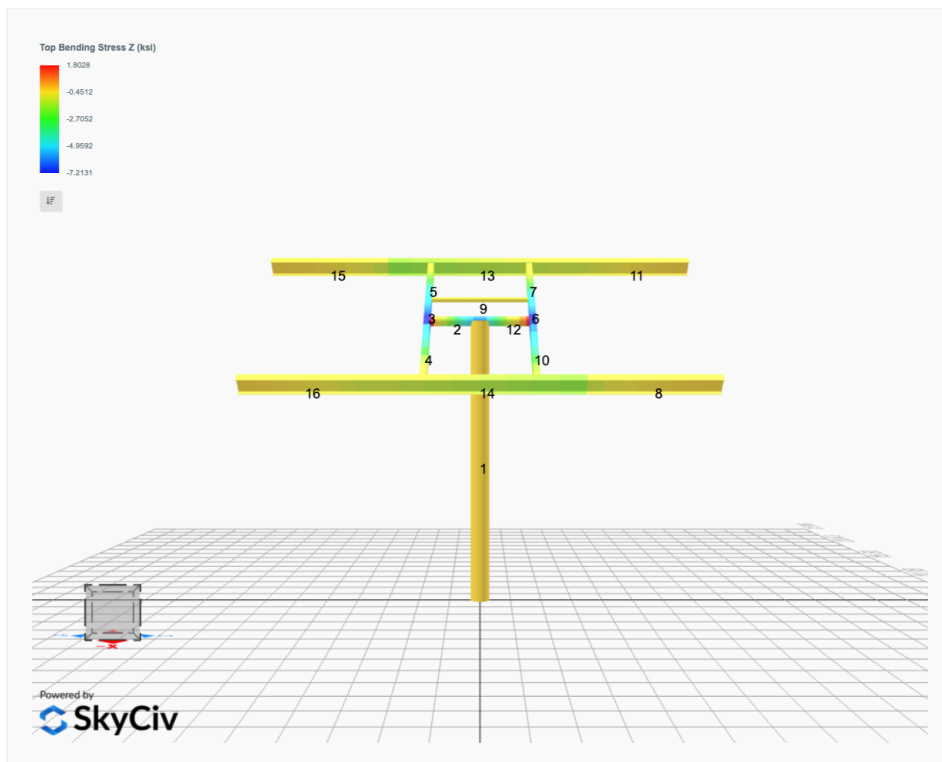
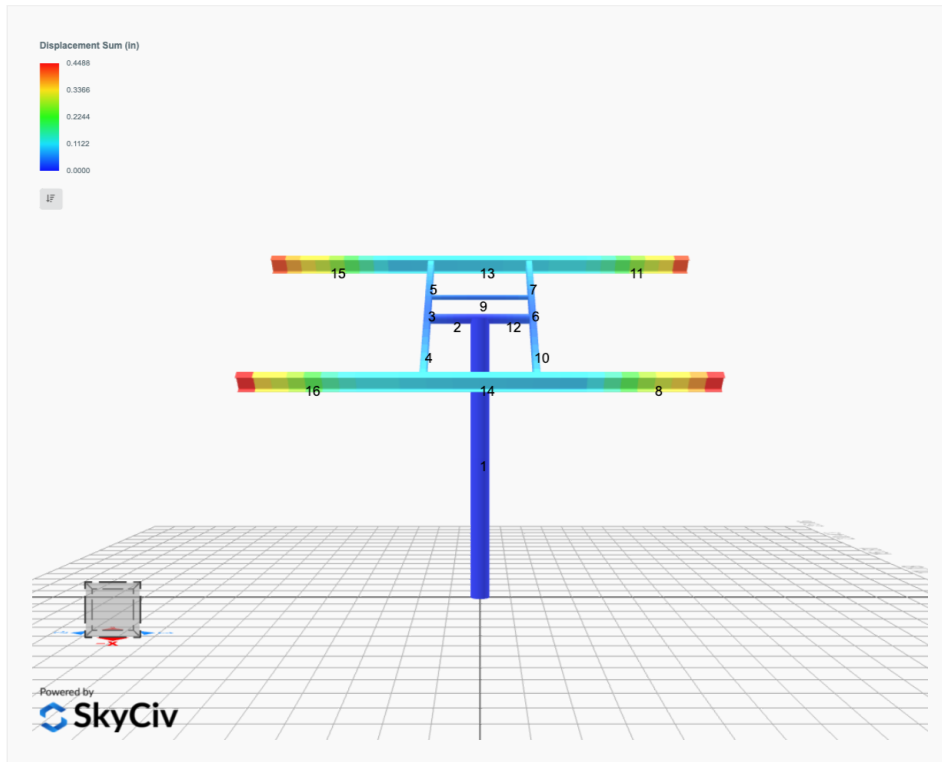

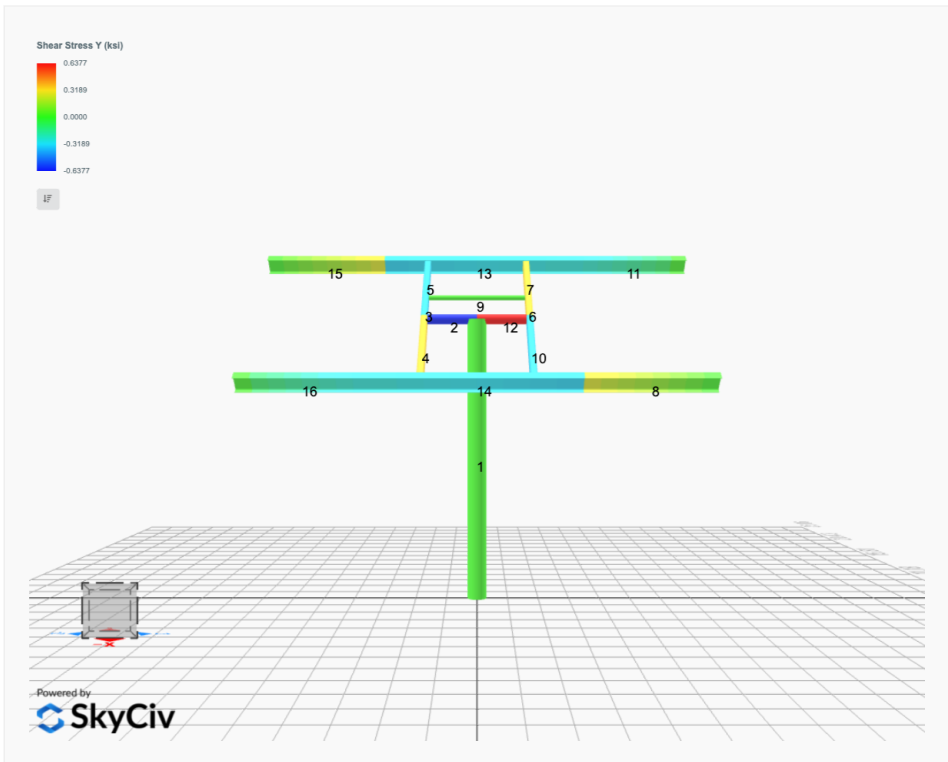
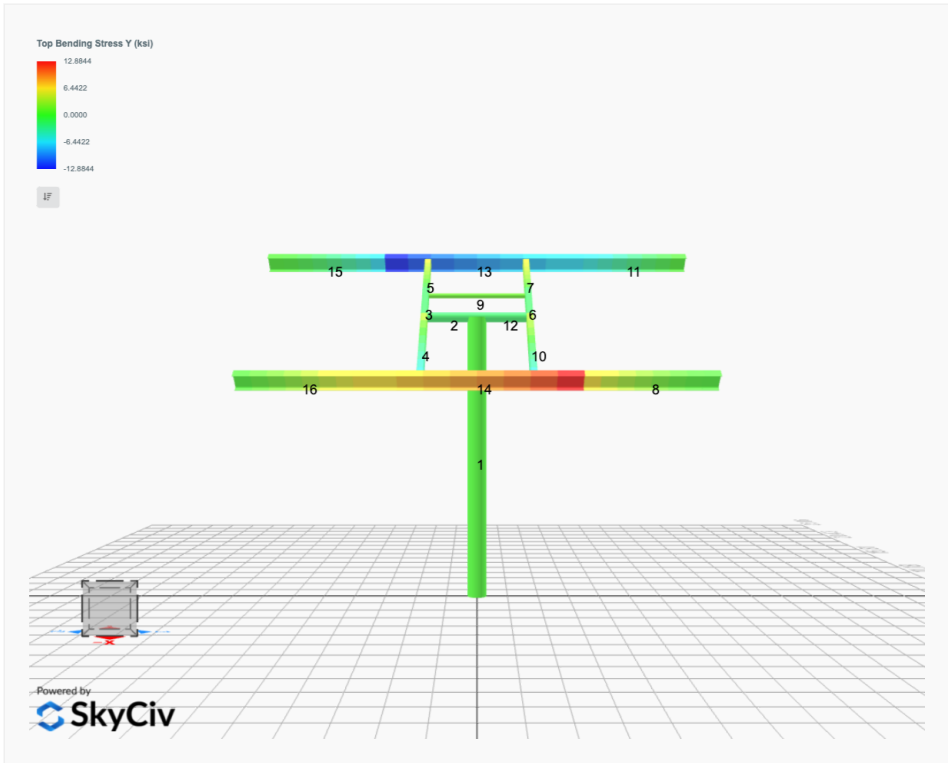

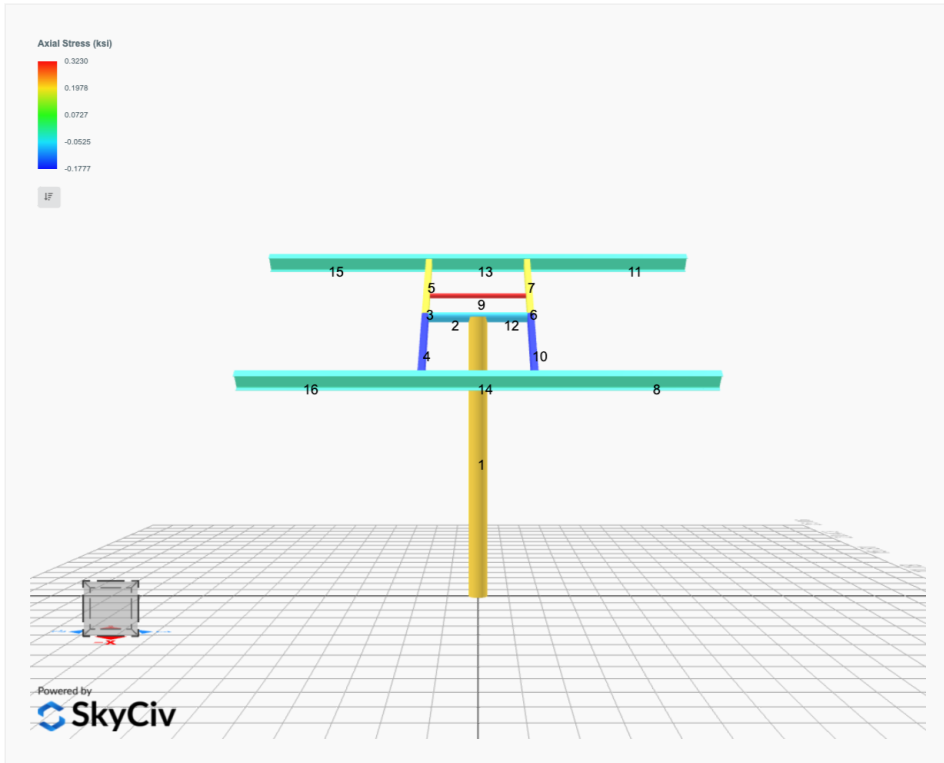

Reaction Forces for Foundation 1 (Node ID#1), (kip, kip-ft)

ASD Load Combination Results

Name	Fx	Fy	Fz	Mx	My	Mz
ULS: 1. D	0.0000	2.4933	0.0000	0.0000	-0.0000	0.0249
ULS: 2. D + L	0.0000	2.4933	0.0000	0.0000	-0.0000	0.0249
ULS: 3. D + (S or Lr or R)	-0.0000	5.3455	0.0000	0.0000	-0.0000	0.0352
ULS: 3. D + (S or Lr or R)	0.0000	2.4933	0.0000	0.0000	-0.0000	0.0249
ULS: 4. D + 0.75L + 0.75(S or Lr or R)	-0.0000	4.6325	0.0000	0.0000	-0.0000	0.0326
ULS: 4. D + 0.75L + 0.75(S or Lr or R)	0.0000	2.4933	0.0000	0.0000	-0.0000	0.0249
ULS: 5b. D + 0.7E	0.0000	2.4933	0.0000	0.0000	-0.0000	0.0249
ULS: 6b. D + 0.75L + 0.75(0.7)E + 0.75S	-0.0000	4.6325	0.0000	0.0000	-0.0000	0.0326
ULS: 8. 0.6D + 0.7E	0.0000	1.4960	0.0000	0.0000	-0.0000	0.0149
ULS: 5a. D + 0.6W_Wind downforce Case A only	-4.3486	7.6757	-0.0000	0.0000	-0.0000	47.6761
ULS: 5a. D + 0.6W_Wind downforce Case B only	-4.3486	7.6757	-0.0000	0.0000	-0.0000	47.6761
ULS: 5a. D + 0.6W_Wind uplift Case A only	3.4658	-1.6370	-0.0000	0.0000	-0.0000	-35.8017
ULS: 5a. D + 0.6W_Wind uplift Case B only	2.9426	-1.0136	0.0000	0.0000	-0.0000	-40.5357
ULS: 6a. D + 0.75L + 0.75(0.6)W + 0.75(S or Lr or R)_Wind downforce Case A only	-3.2614	8.5193	-0.0000	0.0000	-0.0000	35.7710
ULS: 6a. D + 0.75L + 0.75(0.6)W + 0.75(S or Lr or R)_Wind downforce Case B only	-3.2614	8.5193	-0.0000	0.0000	-0.0000	35.7710
ULS: 6a. D + 0.75L + 0.75(0.6)W + 0.75(S or Lr or R)_Wind uplift Case A only	2.5993	1.5347	-0.0000	0.0000	-0.0000	-26.8373
ULS: 6a. D + 0.75L + 0.75(0.6)W + 0.75(S or Lr or R)_Wind uplift Case B only	2.2070	2.0023	0.0000	0.0000	-0.0000	-30.3879
ULS: 6a. D + 0.75L + 0.75(0.6)W + 0.75(S or Lr or R)_Wind downforce Case A only	-3.2614	6.3801	-0.0000	0.0000	-0.0000	35.7633
ULS: 6a. D + 0.75L + 0.75(0.6)W + 0.75(S or Lr or R)_Wind downforce Case B only	-3.2614	6.3801	-0.0000	0.0000	-0.0000	35.7633
ULS: 6a. D + 0.75L + 0.75(0.6)W + 0.75(S or Lr or R)_Wind uplift Case A only	2.5993	-0.6044	-0.0000	0.0000	-0.0000	-26.8450
ULS: 6a. D + 0.75L + 0.75(0.6)W + 0.75(S or Lr or R)_Wind uplift Case B only	2.2070	-0.1369	0.0000	0.0000	-0.0000	-30.3956
ULS: 7. 0.6D + 0.6W_Wind downforce Case A only	-4.3486	6.6784	-0.0000	0.0000	-0.0000	47.6662
ULS: 7. 0.6D + 0.6W_Wind downforce Case B only	-4.3486	6.6784	-0.0000	0.0000	-0.0000	47.6662
ULS: 7. 0.6D + 0.6W_Wind uplift Case A only	3.4658	-2.6344	-0.0000	0.0000	-0.0000	-35.8116
ULS: 7. 0.6D + 0.6W_Wind uplift Case B only	2.9426	-2.0109	0.0000	0.0000	-0.0000	-40.5457

Worst Case Reactions LRFD

These calculations are taken directly from the FEA via SkyCiv and are used in the Concrete Checks of the Foundation Module.
Note: Worst case values are assumed as downforce wind load cases.

Result	Value
Axial	13.0555
Shear X	-7.2476
Shear Z	0.0000
Moment X	-0.0000
Moment Z	80.1746

Worst Case Reactions ASD

These results are taken from the worst case values in the above table and are used in the Soil Checks in the Foundation Module.
Note: Worst case values are assumed as downforce wind load cases.

Result	Value
Axial	8.5193
Shear X	-4.3486
Shear Z	-0.0000
Moment X	0.0000
Moment Z	47.6761

Project Details

Design Code: AISC 360-16 LRFD
 Provision: LRFD
 Country: United States
 User Name: sales@mtsolar.us
 Unit System: imperial



Design Input Information

Design Factors			
Φ_t	Φ_c	Φ_b	Φ_v
0.9	0.9	0.9	0.9

Design Materials			
ID	E (ksi)	F_y (ksi)	F_u (ksi)
1	29000	50	65

Section Dimensions

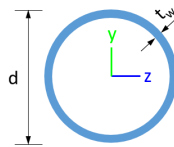

ID	Name	d (in)	t_w (in)				
2	2in Pipe Sch 80	2.38	0.22				
5	4in Pipe Sch 80	4.50	0.34				
10	8in Pipe Sch 80	8.63	0.50				

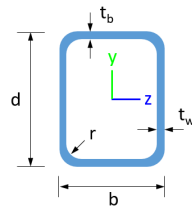

ID	Name	d (in)	b (in)	t_w (in)	t_b (in)	r (in)	
16	HSS5x3x3/16	5.00	3.00	0.17	0.17	0.17	

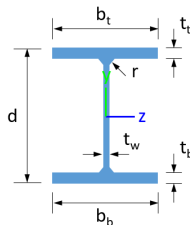

ID	Name	d (in)	t_w (in)	b_t (in)	b_b (in)	t_t (in)	t_b (in)	r (in)
19	W8x10	7.89	0.17	3.94	3.94	0.20	0.20	0.30

Section Properties

ID	Name	A (in ²)	J (in ⁴)	I_{yp} (in ⁴)	I_{zp} (in ⁴)	I_w (in ⁶)	S_{yp} (in ³)	S_{zp} (in ³)
2	2in Pipe Sch 80	1.48	1.74	0.87	0.87	0.00	1.02	1.02
5	4in Pipe Sch 80	4.41	19.22	9.61	9.61	0.00	5.85	5.85
10	8in Pipe Sch 80	12.76	211.43	105.72	105.72	0.00	33.05	33.05

16	HSS5x3x3/16	2.58	8.64	3.85	8.53	92.39	2.96	4.21
19	W8x10	2.96	0.04	2.09	30.80	30.90	1.66	8.87

Member Properties												
Member ID	Section ID	K _z L (ft)	K _y L (ft)	L _b (ft)	C _b	L	S	T	L	S	L	
1	10	22.20	22.20	10.57	-		3	0	0	2	0	1
2	5	2.00	2.00	2.00	-		3	0	0	2	0	1
3	16	1.42	1.42	1.42	1.19,1.18,1.19,1.18,1.18,1.19,1.18,1.18,1.18,1.18,1.18,1.18,1.18,1.18,1.20,1.16,1.18,1.18,1.17,1.17,1.18,1.18,1.18,1.18	3	0	0	2	0	1	
4	16	3.75	3.75	3.75	1.68,1.68,1.68,1.67,1.68,1.68,1.67,1.67,1.66,1.61,1.67,1.67,1.66,1.65,1.67,1.67,1.72,1.68,1.67,1.67,1.66,2.01,1.67,1.67,1.66,1.66	3	0	0	2	0	1	
5	16	2.33	2.33	2.33	1.68,1.67,1.68,1.67,1.67,1.68,1.67,1.67,1.66,1.66,1.67,1.67,1.66,1.66,1.67,1.67,1.69,1.65,1.67,1.67,1.66,1.66,1.67,1.67,1.66,1.67	3	0	0	2	0	1	
6	16	1.42	1.42	1.42	1.19,1.18,1.19,1.18,1.18,1.19,1.18,1.18,1.18,1.18,1.18,1.18,1.18,1.18,1.20,1.16,1.18,1.18,1.17,1.17,1.18,1.18,1.18,1.18	3	0	0	2	0	1	
7	16	2.33	2.33	2.33	1.68,1.67,1.68,1.67,1.67,1.68,1.67,1.67,1.66,1.66,1.67,1.67,1.66,1.66,1.67,1.67,1.69,1.65,1.67,1.67,1.66,1.66,1.67,1.67,1.66,1.67	3	0	0	2	0	1	
8	19	4.75	4.75	4.75	2.33,2.33	3	0	0	2	0	1	
9	2	4.00	4.00	4.00	-		3	0	0	2	0	1
10	16	3.75	3.75	3.75	1.68,1.68,1.68,1.67,1.68,1.68,1.67,1.67,1.66,1.61,1.67,1.67,1.66,1.65,1.67,1.67,1.72,1.68,1.67,1.67,1.66,2.00,1.67,1.67,1.66,1.66	3	0	0	2	0	1	
11	19	4.75	4.75	4.75	2.33,2.33	3	0	0	2	0	1	
12	5	2.00	2.00	2.00	-		3	0	0	2	0	1
13	19	1.75	1.75	1.75	1.25,1.25	3	0	0	2	0	1	
14	19	1.75	1.75	1.75	1.25,1.25	3	0	0	2	0	1	
15	19	4.75	4.75	4.75	2.33,2.33	3	0	0	2	0	1	
16	19	4.75	4.75	4.75	2.33,2.33	3	0	0	2	0	1	
17	19	4.00	4.00	4.00	1.07,1.09,1.07,1.07,1.07,1.07	3	0	0	2	0	1	
18	19	1.75	1.75	1.75	1.25,1.25	3	0	0	2	0	1	
19	19	4.00	4.00	4.00	1.06,1.06,1.06,1.06,1.06,1.06,1.06,1.06,1.06,1.06,1.03,1.06,1.06,1.06,1.06,1.05,1.06,1.06,1.06,1.07,1.06,1.06,1.06,1.00,1.06,1.06,1.05	3	0	0	2	0	1	
20	19	1.75	1.75	1.75	1.25,1.25	3	0	0	2	0	1	

Member Design Capacity

Member ID	Φ _t P _n (kip)	Φ _c P _n (kip)	Φ _b M _{zn} (k-ft)	Φ _b M _{yn} (k-ft)	Φ _v V _{yn} (kip)	Φ _v V _{zn} (kip)
1	574.32	306.99	123.94	123.94	172.30	172.30
2	100.33	101.54	21.05	21.05	50.50	50.50
3	100.33	101.54	21.05	21.05	50.50	50.50
4	100.33	101.54	21.05	21.05	50.50	50.50
5	100.33	101.54	21.05	21.05	50.50	50.50
6	100.33	101.54	21.05	21.05	50.50	50.50
7	100.33	101.54	21.05	21.05	50.50	50.50
8	100.33	101.54	21.05	21.05	50.50	50.50
9	100.33	101.54	21.05	21.05	50.50	50.50
10	100.33	101.54	21.05	21.05	50.50	50.50
11	100.33	101.54	21.05	21.05	50.50	50.50
12	100.33	101.54	21.05	21.05	50.50	50.50
13	100.33	101.54	21.05	21.05	50.50	50.50
14	100.33	101.54	21.05	21.05	50.50	50.50
15	100.33	101.54	21.05	21.05	50.50	50.50
16	100.33	101.54	21.05	21.05	50.50	50.50
17	100.33	101.54	21.05	21.05	50.50	50.50
18	100.33	101.54	21.05	21.05	50.50	50.50
19	100.33	101.54	21.05	21.05	50.50	50.50
20	100.33	101.54	21.05	21.05	50.50	50.50

2	198.33	194.54	21.95	21.95	59.50	59.50
3	116.10	114.47	15.79	11.10	42.08	23.28
4	116.10	105.13	15.79	11.10	42.08	23.28
5	116.10	111.72	15.79	11.10	42.08	23.28
6	116.10	114.47	15.79	11.10	42.08	23.28
7	116.10	111.72	15.79	11.10	42.08	23.28
8	133.20	95.15	32.87	6.12	40.24	43.62
9	66.48	49.90	3.82	3.82	19.94	19.94
10	116.10	105.13	15.79	11.10	42.08	23.28
11	133.20	95.15	32.87	6.12	40.24	43.62
12	198.33	194.54	21.95	21.95	59.50	59.50
13	133.20	123.94	32.87	6.12	40.24	43.62
14	133.20	123.94	32.87	6.12	40.24	43.62
15	133.20	95.15	32.87	6.12	40.24	43.62
16	133.20	95.15	32.87	6.12	40.24	43.62
17	133.20	104.94	32.87	6.12	40.24	43.62
18	133.20	123.94	32.87	6.12	40.24	43.62
19	133.20	104.94	30.91	6.12	40.24	43.62
20	133.20	123.94	32.87	6.12	40.24	43.62

Design Ratio

Member ID	P	M _z	M _y	V _y	V _z	(P,M _z ,M _y)	Worst LC	KL/r	δ	Status
1	0.043	0.647	0.000	0.042	0.000	0.668	#13	0.463	Not Required	Pass
2	0.004	0.491	0.325	0.105	0.061	0.817	#13	0.054	Not Required	Pass
3	0.010	0.868	0.048	0.087	0.001	0.898	#13	0.070	Not Required	Pass
4	0.010	0.814	0.185	0.082	0.038	0.879	#13	0.123	Not Required	Pass
5	0.010	0.539	0.191	0.086	0.049	0.567	#13	0.115	Not Required	Pass
6	0.010	0.868	0.048	0.087	0.001	0.898	#13	0.070	Not Required	Pass
7	0.010	0.539	0.191	0.086	0.049	0.567	#13	0.115	Not Required	Pass
8	0.000	0.137	0.235	0.047	0.014	0.342	#21	Not Required	Not Required	Pass
9	0.022	0.073	0.068	0.001	0.000	0.146	#13	0.313	Not Required	Pass
10	0.010	0.814	0.185	0.082	0.038	0.879	#13	0.123	Not Required	Pass
11	0.000	0.146	0.235	0.050	0.014	0.347	#21	Not Required	Not Required	Pass
12	0.004	0.491	0.325	0.105	0.061	0.817	#13	0.054	Not Required	Pass
13	0.000	0.273	0.441	0.069	0.019	0.649	#21	Not Required	Not Required	Pass
14	0.000	0.257	0.441	0.065	0.019	0.641	#21	Not Required	Not Required	Pass
15	0.000	0.146	0.235	0.050	0.014	0.347	#21	Not Required	Not Required	Pass
16	0.000	0.137	0.235	0.047	0.014	0.342	#21	Not Required	Not Required	Pass
17	0.009	0.286	0.093	0.021	0.006	0.338	#13	0.190	Not Required	Pass
18	0.000	0.273	0.441	0.069	0.019	0.649	#21	Not Required	Not Required	Pass
19	0.008	0.276	0.106	0.020	0.006	0.335	#13	0.286	Not Required	Pass
20	0.000	0.257	0.441	0.065	0.019	0.641	#21	Not Required	Not Required	Pass

Definitions

Φ_t	Safety factor for tensile
Φ_c	Safety factor for compression
Φ_b	Safety factor for flexure
Φ_v	Safety factor for shear
E	Modulus of elasticity
F _y	Specified minimum yield stress
F _u	Specified minimum tensile strength
A	Cross-sectional area
J	Torsional constant
I _y	Moment of inertia about the Y axis

I_{yp}	Moment of inertia about the Y axes
I_{zp}	Moment of inertia about the Z axes
I_w	Warping constant
S_{yp}	Plastic section modulus about the Y axis
S_{zp}	Plastic section modulus about the Z axis
KL	Effective length
C_b	Buckling modification factor (from all load combinations)
L_b	Length between braced points
LST	Limited slenderness for tension
LSC	Limited slenderness for compression
LD	Limited deflection
P_n	Nominal axial strength (tension/compression)
M_n	Nominal flexural strength (about Z/Y axis)
V_n	Nominal shear strength (along Z/Y axis)
P	Design ratio in case of axial force
M_z	Design ratio in case of bending about Z axis
M_y	Design ratio in case of bending about Y axis
V_y	Design ratio in case of shear along Y axis
V_z	Design ratio in case of shear along Z axis
(P, M_z, M_y)	Design ratio in case of axial force and bending action
KL/r	Design ratio in case of section slenderness
δ	Design ratio in case of member deflection
OK	Capacity is provided
NG	Capacity is not provided

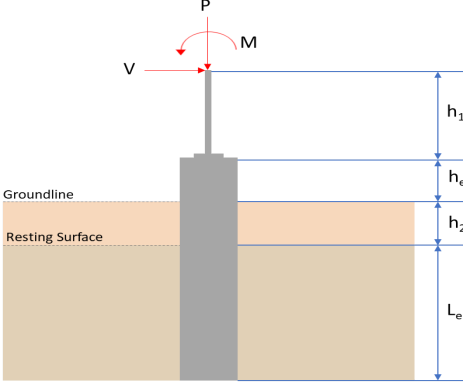
REFERENCES	CALCULATIONS	RESULTS																										
	<p>SkyCiv Foundation Design Pile Foundation</p> <p>Design Information : Design code : IBC 2021 (International Building Code) Unit System : Imperial</p>																											
	<p>Pile Input</p>  <p>Geometry Pile shape: rectangular $b = 48$ in - Pile width $D = 48$ in - Pile depth $L = 7.5$ ft - Total pile length $h_1 = 0$ ft - Lateral load height from the top of the pile, $h_2 = 0$ ft - Depth to resting surface $h_e = 0$ ft - Length of pile above the ground</p> <p>Tabulation of Soil Parameters</p> <table border="1" data-bbox="416 1102 1193 1191"> <thead> <tr> <th>Layer</th> <th>Label</th> <th>Allowable Bearing Pressure (q_a) (psf)</th> <th>Allowable Lateral Pressure (R) (psf/ft)</th> </tr> </thead> <tbody> <tr> <td>1</td> <td>Sand, silty sand, clayey sand, silty gravel & clayey gravel</td> <td>2000.000</td> <td>150.000</td> </tr> </tbody> </table> <p>Tabulation of Loads</p> <table border="1" data-bbox="676 1288 933 1458"> <thead> <tr> <th>Load Component</th> <th>ASD</th> <th>LRFD</th> </tr> </thead> <tbody> <tr> <td>P (kip)</td> <td>8.519</td> <td>13.055</td> </tr> <tr> <td>V_x (kip)</td> <td>-4.349</td> <td>-7.248</td> </tr> <tr> <td>V_z (kip)</td> <td>0.000</td> <td>0.000</td> </tr> <tr> <td>M_x (kipft)</td> <td>0.000</td> <td>0.000</td> </tr> <tr> <td>M_z (kipft)</td> <td>47.676</td> <td>80.175</td> </tr> </tbody> </table> <p>Material Properties $f'_{ck} = 3$ ksi - Concrete strength,</p>	Layer	Label	Allowable Bearing Pressure (q_a) (psf)	Allowable Lateral Pressure (R) (psf/ft)	1	Sand, silty sand, clayey sand, silty gravel & clayey gravel	2000.000	150.000	Load Component	ASD	LRFD	P (kip)	8.519	13.055	V_x (kip)	-4.349	-7.248	V_z (kip)	0.000	0.000	M_x (kipft)	0.000	0.000	M_z (kipft)	47.676	80.175	
Layer	Label	Allowable Bearing Pressure (q_a) (psf)	Allowable Lateral Pressure (R) (psf/ft)																									
1	Sand, silty sand, clayey sand, silty gravel & clayey gravel	2000.000	150.000																									
Load Component	ASD	LRFD																										
P (kip)	8.519	13.055																										
V_x (kip)	-4.349	-7.248																										
V_z (kip)	0.000	0.000																										
M_x (kipft)	0.000	0.000																										
M_z (kipft)	47.676	80.175																										
	<p>Required depth to resist lateral loads (ASD) H - Point of application of the lateral load</p> $H = h_1 + h_2 + h_e$ $H = (0 \text{ ft}) + (0 \text{ ft}) + (0 \text{ ft})$ $H = 0 \text{ ft}$ <p>Considering x-direction: H_o - Lateral force per length of pile,</p> $H_o = \frac{V_x}{1.57 D}$ $H_o = \frac{(-4.349 \text{ kip})}{1.57 \times (48 \text{ in})}$ $H_o = -0.69252 \text{ kip/ft}$ <p>M_o - Moment per length of pile,</p> $M_o = \frac{M_z + (V_x H)}{1.57 D}$																											

$$M_o = \frac{(47.676 \text{ kipft}) + ((-4.349 \text{ kip}) \times (0 \text{ ft}))}{1.57 \times (48 \text{ in})}$$

$$M_o = 7.5917 \text{ kipft/ft}$$

Required depth of embedment in earth:

$$L_x^3 - \left(14.14 \times \frac{H_o \times L_x}{R}\right) - \left(18.85 \times \frac{M_o}{R}\right) = 0$$

Solving the cubic equation:

$$L_{e,x} = 6.8571 \text{ ft} - \text{Required depth in x-direction,}$$

Considering z-direction:

$$L_{e,z} = 0 \text{ ft} - \text{Required depth in z-direction,}$$

Minimum embedded depth required:

$L_{e,req}$ - Depth of pile required,

$$L_{e,req} = \text{MAX}[L_{e,x}, L_{e,z}]$$

$$L_{e,req} = \text{MAX}[(6.8571 \text{ ft}), (0 \text{ ft})]$$

$$L_{e,req} = 6.857 \text{ ft}$$

L_e - Actual embedded length of pile,

$$L_e = L - h_e - h_2$$

$$L_e = (7.5 \text{ ft}) - (0 \text{ ft}) - (0 \text{ ft})$$

$$L_e = 7.5 \text{ ft}$$

Ratio - Embedded depth

$$\text{Ratio} = \frac{L_{e,req}}{L_e}$$

$$\text{Ratio} = \frac{(6.857 \text{ ft})}{(7.5 \text{ ft})}$$

$$\text{Ratio} = 0.91427$$

Status: **PASS**
Ratio: **0.910**

End-bearing Capacity (ASD)

A - Pile cross-section area

$$A = b D$$

$$A = (48 \text{ in}) \times (48 \text{ in})$$

$$A = 16 \text{ ft}^2$$

q - End-bearing pressure

$$q = \frac{P_v}{A}$$

$$q = \frac{(8.519 \text{ kip})}{(16 \text{ ft}^2)}$$

$$q = 0.53244 \text{ kip/ft}^2$$

Check bearing capacity ratio:

Ratio - Capacity

$$\text{Ratio} = \frac{q}{q_o}$$

$$\text{Ratio} = \frac{(0.53244 \text{ kip/ft}^2)}{(2000 \text{ psf})}$$

$$\text{Ratio} = 0.26622$$

Status: **PASS**
Ratio: **0.270**

Czerniak

Lateral Soil Pressure (ASD):

L/D - Length to least lateral dimension ratio,

$$L/D = \frac{L}{D}$$

$$L/D = \frac{(7.5 \text{ ft})}{(48 \text{ in})}$$

$$L/D = 1.875$$

Since $L/D \leq 10$,

Pile is short.

Considering x-direction:

$H_o = -0.69252$ kip/ft - Lateral force per length of pile,

$M_o = 7.5917$ kipft/ft - Overturning moment per length of pile,

a - Distance from resting surface to pivot point,

$$a = \frac{(4 M_o L_e) + (3 H_o L_e^2)}{(6 M_o) + (4 H_o L_e)}$$

$$a = \frac{(4 \times (7.5917 \text{ kipft/ft}) \times (7.5 \text{ ft})) + (3 \times (-0.69252 \text{ kip/ft}) \times (7.5 \text{ ft})^2)}{(6 \times (7.5917 \text{ kipft/ft})) + (4 \times (-0.69252 \text{ kip/ft}) \times (7.5 \text{ ft}))}$$

$$a = 5.1958 \text{ ft}$$

p - Earth pressure against the pile at distance $a/2$ from resting surface,

$$p = \frac{0.75 [(4 M_o) + (3 H_o L_e)]^2}{L_e^2 [(3 M_o) + (2 H_o L_e)]}$$

$$p = \frac{0.75 \times [(4 \times (7.5917 \text{ kipft/ft})) + (3 \times (-0.69252 \text{ kip/ft}) \times (7.5 \text{ ft}))]^2}{(7.5 \text{ ft})^2 \times [(3 \times (7.5917 \text{ kipft/ft})) + (2 \times (-0.69252 \text{ kip/ft}) \times (7.5 \text{ ft}))]}$$

$$p = 0.2353 \text{ kip/ft}^2$$

s - Earth pressure against the pile at distance L_e ,

$$s = \frac{6 [(2 M_o) + (H_o L_e)]}{L_e^2}$$

$$s = \frac{6 \times [(2 \times (7.5917 \text{ kipft/ft})) + ((-0.69252 \text{ kip/ft}) \times (7.5 \text{ ft}))]}{(7.5 \text{ ft})^2}$$

$$s = 1.0656 \text{ kip/ft}^2$$

Check lateral soil pressure capacity:

p_a - Allowable lateral soil pressure at depth $a/2$,

$$p_a = R \frac{a}{2}$$

$$p_a = (150 \text{ psf/ft}) \times \frac{(5.1958 \text{ ft})}{2}$$

$$p_a = 0.38968 \text{ kip/ft}^2$$

Ratio - Lateral soil capacity

$$\text{Ratio} = \frac{p}{p_a}$$

$$\text{Ratio} = \frac{(0.2353 \text{ kip/ft}^2)}{(0.38968 \text{ kip/ft}^2)}$$

$$\text{Ratio} = 0.60382$$

p_s - Allowable lateral soil pressure at depth L_e ,

$$p_s = R L_e$$

$$p_s = (150 \text{ psf/ft}) \times (7.5 \text{ ft})$$

$$p_s = 1.125 \text{ kip/ft}^2$$

Ratio - Lateral soil capacity

$$\text{Ratio} = \frac{s}{p_s}$$

$$\text{Ratio} = \frac{(1.0656 \text{ kip/ft}^2)}{(1.125 \text{ kip/ft}^2)}$$

$$\text{Ratio} = 0.94716$$

Status: **PASS**
Ratio: **0.600**

Status: **PASS**
Ratio: **0.950**

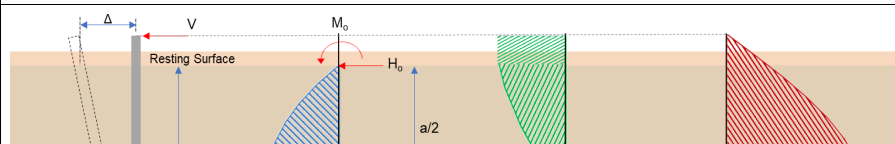

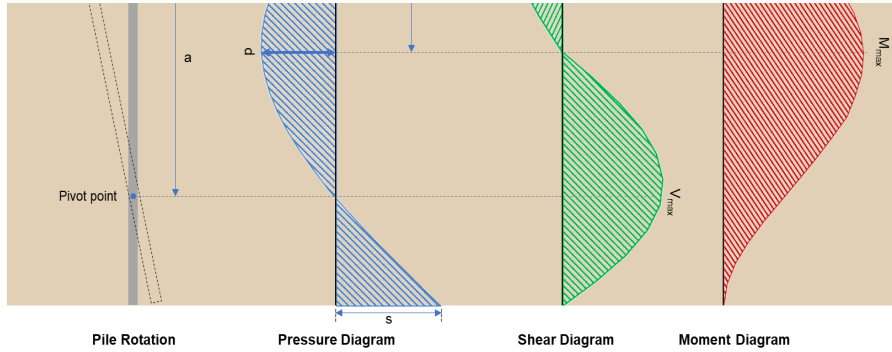

Shear force and Bending moment (x-direction, LRFD)

H_o - Lateral force per length of pile,

$$H_o = \frac{V_x}{1.57 D}$$

$$H_o = \frac{(-7.248 \text{ kip})}{1.57 \times (48 \text{ in})}$$

$$H_o = -1.1541 \text{ kip/ft}$$

M_o - Moment per length of pile,

$$M_o = \frac{M_x + (V_x H)}{1.57 D}$$

$$M_o = \frac{(80.175 \text{ kipft}) + ((-7.248 \text{ kip}) \times (0 \text{ ft}))}{1.57 \times (48 \text{ in})}$$

$$M_o = 12.767 \text{ kipft/ft}$$

E - Distance from lateral load to resisting surface,

$$E = \frac{M_o}{H_o}$$

$$E = \frac{(12.767 \text{ kipft/ft})}{(-1.1541 \text{ kip/ft})}$$

$$E = 11.062 \text{ ft}$$

a - Distance from resting surface to pivot point,

$$a = \frac{(4 M_o L_c) + (3 H_o L_c^2)}{(6 M_o) + (4 H_o L_c)}$$

$$a = \frac{(4 \times (12.767 \text{ kipft/ft}) \times (7.5 \text{ ft})) + (3 \times (-1.1541 \text{ kip/ft}) \times (7.5 \text{ ft})^2)}{(6 \times (12.767 \text{ kipft/ft})) + (4 \times (-1.1541 \text{ kip/ft}) \times (7.5 \text{ ft}))}$$

$$a = 5.1946 \text{ ft}$$

V_{max} - Max shear force located at depth a ,

$$V_{max} = (H_o D) \left[1 - \left[3 \left(\frac{4 E}{L_c} + 3 \right) \left(\frac{a}{L_c} \right)^2 \right] + \left[4 \left(\frac{3 E}{L_c} + 2 \right) \left(\frac{a}{L_c} \right)^3 \right] \right]$$

$$V_{max} = ((-1.1541 \text{ kip/ft}) \times (48 \text{ in})) \times \left[1 - \left[3 \times \left(\frac{4 \times (11.062 \text{ ft})}{(7.5 \text{ ft})} + 3 \right) \times \left(\frac{(5.1946 \text{ ft})}{(7.5 \text{ ft})} \right)^2 \right] + \left[4 \times \left(\frac{3 \times (11.062 \text{ ft})}{(7.5 \text{ ft})} + 2 \right) \times \left(\frac{(5.1946 \text{ ft})}{(7.5 \text{ ft})} \right)^3 \right] \right]$$

$$V_{max} = 15.092 \text{ kip}$$

M_{max} - Max bending moment located at depth $a/2$,

$$M_{max} = (H_o D L_c) \left[\left(\frac{E}{L_c} + \frac{a}{2 L_c} \right) - \left[\left(\frac{4 E}{L_c} + 3 \right) \left(\frac{a}{2 L_c} \right)^3 \right] + \left[\left(\frac{3 E}{L_c} + 2 \right) \left(\frac{a}{2 L_c} \right)^4 \right] \right]$$

$$M_{max} = ((-1.1541 \text{ kip/ft}) \times (48 \text{ in}) \times (7.5 \text{ ft})) \times \left[\left(\frac{(11.062 \text{ ft})}{(7.5 \text{ ft})} + \frac{(5.1946 \text{ ft})}{2 \times (7.5 \text{ ft})} \right) - \left[\left(\frac{4 \times (11.062 \text{ ft})}{(7.5 \text{ ft})} + 3 \right) \times \left(\frac{(5.1946 \text{ ft})}{(2 \times (7.5 \text{ ft}))} \right)^3 \right] + \left[\left(\frac{3 \times (11.062 \text{ ft})}{(7.5 \text{ ft})} + 2 \right) \times \left(\frac{(5.1946 \text{ ft})}{(2 \times (7.5 \text{ ft}))} \right)^4 \right] \right]$$

$$M_{max} = 53.459 \text{ kipft}$$

Minimum Reinforcement Check (LRFD)

Parameters:

$f'_{ck} = 3 \text{ ksi}$ - Concrete strength,
 $f_{yk} = 60 \text{ ksi}$ - Longitudinal reinforcement strength,
 $\phi = 0.65$ - Reduction factor for axial strength,
 $\alpha = 0.8$ - Alpha factor for axial strength,
 $A_g = 2304 \text{ in}^2$ - Gross area of concrete,

Table 22.4.2.1

Longitudinal reinforcement:

Required reinforcement due to axial load, $A_{st,required}$

22.4.2.2, 10.6.1.1

$A_{st,required}$

$$A_{st,required} = \text{Min} \left[\frac{\frac{P}{\phi \alpha} - (0.85 f'_{ck} A_g)}{f_{yk} - (0.85 f'_{ck})}, (0.08 A_g) \right]$$

$$A_{st,required} = \text{Min} \left[\frac{\frac{(13.055 \text{ kip})}{(0.65) \times (0.8)} - (0.85 \times (3 \text{ ksi}) \times (2304 \text{ in}^2))}{(60 \text{ ksi}) - (0.85 \times (3 \text{ ksi}))}, (0.08 \times (2304 \text{ in}^2)) \right]$$

$$A_{st,required} = -101.83 \text{ in}^2$$

A_{min} - Governing minimum reinforcement area,

$$A_{min} = \text{Max} [A_{st,required}, (0.0018 A_g)]$$

$$A_{min} = \text{Max} [(-101.83 \text{ in}^2), (0.0018 \times (2304 \text{ in}^2))]$$

$$A_{min} = 4.1472 \text{ in}^2$$

n_{rebar} - Required number of reinforcement,

$$n_{rebar} = \frac{A_{min}}{A_{rebar}}$$

$$n_{rebar} = \frac{(4.1472 \text{ in}^2)}{(0.3068 \text{ in}^2)}$$

$$n_{rebar} = 14$$

A_{st} - Actual total reinforcement area,

$$A_{st} = n_{rebar} \frac{\pi d_{bar}^2}{4}$$

$$A_{st} = (14) \times \frac{\pi \times (0.625 \text{ in})^2}{4}$$

$$A_{st} = 4.2951 \text{ in}^2$$

Ratio - Capacity

$$\text{Ratio} = \frac{A_{min}}{A_{st}}$$

$$\text{Ratio} = \frac{(4.1472 \text{ in}^2)}{(4.2951 \text{ in}^2)}$$

$$\text{Ratio} = 0.96556$$

Status: **PASS**
Ratio: **0.970**

25.2.3

s_{rebar} - Minimum spacing of reinforcement,

$$s_{rebar} = \text{Max} [1.5, (1.5 d_{bar})]$$

$$s_{rebar} = \text{Max} [1.5, (1.5 \times (0.625 \text{ in}))]$$

$$s_{rebar} = 1.5 \text{ in}$$

Ties:

25.7.2.2 Since longitudinal reinforcement is \leq No. 10: Use #3(0.375 in)

25.7.2.1 s_{ties} - Maximum spacing of ties,

$$s_{ties} = \text{Min} [(16 d_{bar}), (48 d_{ties}), \text{Min} (D, b)]$$

$$s_{ties} = \text{Min} [(16 \times (0.625 \text{ in})), (48 \times (0.375 \text{ in})), \text{Min} ((48 \text{ in}), (48 \text{ in}))]$$

$$s_{ties} = 10 \text{ in}$$

Summary:

Main reinforcement: **14 - #5 (0.625 in)**

Axial Compression Strength (ACI 318-19, LRFD)22.4.2.2 ϕP_N - Allowable axial compressive strength

$$\phi P_N = \phi 0.80 [(0.85 f'_{ck} [A_g - A_{st}] + (f_{yk} A_{st})]$$

$$\phi P_N = (0.65) \times 0.80 \times [(0.85 \times (3 \text{ ksi}) \times [(2304 \text{ in}^2) - (4.2951 \text{ in}^2)]) + ((60 \text{ ksi}) \times (4.2951 \text{ in}^2))]$$

$$\phi P_N = 3183.4 \text{ kip}$$

Ratio - Capacity

$$\text{Ratio} = \frac{P}{\phi P_N}$$

$$\text{Ratio} = \frac{(13.055 \text{ kip})}{(3183.4 \text{ kip})}$$

$$\text{Ratio} = 0.0041009$$

Status: **PASS**
Ratio: **0.000****Shear Strength (ACI 318-19, LRFD)****Parameters:** $b_w = 48 \text{ in}$ - Effective width,22.5.2.2 d - Effective depth

$$d = 0.80 D$$

$$d = 0.80 \times (48 \text{ in})$$

$$d = 38.4 \text{ in}$$

22.5.5.1.3 λ_s - size effect modification factor

$$\lambda_s = \text{MIN} \left[\sqrt{\frac{2}{1 + \frac{d}{10}}}, 1 \right]$$

$$\lambda_s = \text{MIN} \left[\sqrt{\frac{2}{1 + \frac{(38.4 \text{ in})}{10}}}, 1 \right]$$

$$\lambda_s = 0.64282$$

The following variables were converted to be consistent with empirical formula $f'_{ck} = 3 \text{ ksi} \rightarrow 3000 \text{ psi}$,22.5.5.1.1 $V_{c,max}$ - Max shear strength of concrete

$$V_{c,max} = 5 \lambda_s \sqrt{f'_{ck}} b_w d$$

$$V_{c,max} = 5 \times (0.64282) \times \sqrt{(3000 \text{ psi})} \times (48 \text{ in}) \times (38.4 \text{ in})$$

$$V_{c,max} = 324.49 \text{ kip}$$

The following variables were converted to be consistent with empirical formula $f'_{ck} = 3 \text{ ksi} \rightarrow 3000 \text{ psi}$, $P = 13.055 \text{ kip} \rightarrow 13055 \text{ lbf}$,22.5.5.1.1(a) $V_{c,a}$ - Shear strength of concrete (a)

$$V_{c,a} = \left[2 \lambda_s \sqrt{f'_{ck}} + \frac{P}{6 A_g} \right] b_w d$$

$$V_{c,a} = \left[2 \times (0.64282) \times \sqrt{(3000 \text{ psi})} + \frac{(13055 \text{ lbf})}{6 \times (2304 \text{ in}^2)} \right] \times (48 \text{ in}) \times (38.4 \text{ in})$$

$$V_{c,a} = 131.53 \text{ kip}$$

The following variables were converted to be consistent with empirical formula $f'_{ck} = 3 \text{ ksi} \rightarrow 3000 \text{ psi}$,22.5.5.1.2 $V_{c,b}$ - Shear strength of concrete (b)

$$V_{c,b} = \left[2 \lambda_s \sqrt{f'_{ck}} + (0.05 f'_{ck}) \right] b_w d$$

$$V_{c,b} = \left[2 \times (0.64282) \times \sqrt{(3000 \text{ psi})} + (0.05 \times (3000 \text{ psi})) \right] \times (48 \text{ in}) \times (38.4 \text{ in})$$

$$V_{c,b} = 406.27 \text{ kip}$$

 V_c - Governing shear strength of concrete

$$V_c = \text{Min}[V_{c,max}, V_{c,a}, V_{c,b}]$$

$$V_c = \text{Min}[(324.49 \text{ kip}), (131.53 \text{ kip}), (406.27 \text{ kip})]$$

$$V_c = 131.53 \text{ kip}$$

<p>22.5.1.2</p>	<p>The following variables were converted to be consistent with empirical formula $f'_{ck} = 3 \text{ ksi} \rightarrow 3000 \text{ psi}$.</p> <p>$V_{s,a}$ - Shear strength of steel (a)</p> $V_{s,a} = 8 \sqrt{f'_{ck}} b_w d$ $V_{s,a} = 8 \times \sqrt{(3000 \text{ psi})} \times (48 \text{ in}) \times (38.4 \text{ in})$ $V_{s,a} = 807.65 \text{ kip}$ <p>A_v - Ties rebar area,</p> $A_v = \frac{\pi d_{ties}^2}{4}$ $A_v = \frac{\pi \times (0.375 \text{ in})^2}{4}$ $A_v = 0.11045 \text{ in}^2$ <p>22.5.8.5.3 $V_{s,b}$ - Shear strength of steel (b)</p> $V_{s,b} = \frac{2 A_v f_{ywk} d}{s_{ties}}$ $V_{s,b} = \frac{2 \times (0.11045 \text{ in}^2) \times (60 \text{ ksi}) \times (38.4 \text{ in})}{(10 \text{ in})}$ $V_{s,b} = 50.894 \text{ kip}$ <p>V_s - Governing shear strength of steel</p> $V_s = \text{MIN}[V_{s,a}, V_{s,b}]$ $V_s = \text{MIN}[(807.65 \text{ kip}), (50.894 \text{ kip})]$ $V_s = 50.894 \text{ kip}$ <p>22.5.1.1 ϕV_n - Allowable shear strength</p> $\phi V_n = \phi (V_c + V_s)$ $\phi V_n = (0.65) \times ((131.53 \text{ kip}) + (50.894 \text{ kip}))$ $\phi V_n = 118.58 \text{ kip}$ <p>Considering x-direction:</p> <p>$V_{max} = 15.092 \text{ kip}$ - Maximum shear force in the x-direction, Ratio - Capacity</p> $\text{Ratio} = \frac{V_{max}}{\phi V_n}$ $\text{Ratio} = \frac{(15.092 \text{ kip})}{(118.58 \text{ kip})}$ $\text{Ratio} = 0.12728$	<p>Status: PASS Ratio: 0.130</p>
<p>14.5.2.1b</p>	<p>Flexural Strength (ACI 318-19, LFRD)</p> <p>S_m - Section modulus</p> $S_m = \frac{b D^2}{6}$ $S_m = \frac{(48 \text{ in}) \times (48 \text{ in})^2}{6}$ $S_m = 18432 \text{ in}^3$ <p>$\lambda = 1$ - Concrete modification factor (Normal concrete), Allowable flexural strength: M_n shall be the lesser of:</p> <p>$\phi M_{n,1}$</p> $\phi M_{n,1} = \phi \times 5 \times \lambda \times \sqrt{f'_c} \times S_m$ $\phi M_{n,1} = 0.65 \times 5 \times 1 \times \sqrt{(3 \text{ ksi})} \times 18432.001 \text{ in}^3$ $\phi M_{n,1} = 273.423 \text{ kip ft}$ <p>$\phi M_{n,2}$</p> $\phi M_{n,2} = \phi \times 0.85 \times f'_c \times S_m$	

$$\phi M_{n,z} = \phi S_{xx} F_{ck} \leq m$$

$$\phi M_{n,z} = (0.65) \times 0.85 \times (3 \text{ ksi}) \times (18432 \text{ in}^3)$$

$$\phi M_{n,z} = 2545.9 \text{ kipft}$$

Therefore,
 ϕM_n - Allowable flexural strength,

$$\phi M_n = \text{MIN}[\phi M_{n,1}, \phi M_{n,2}]$$

$$\phi M_n = \text{MIN}[(273.42 \text{ kipft}), (2545.9 \text{ kipft})]$$

$$\phi M_n = 273.42 \text{ kipft}$$

Considering x-direction:

$M_{max} = 53.459 \text{ kipft}$ - Maximum moment in the x-direction,

Ratio - Capacity

$$\text{Ratio} = \frac{M_{max}}{\phi M_n}$$

$$\text{Ratio} = \frac{(53.459 \text{ kipft})}{(273.42 \text{ kipft})}$$

$$\text{Ratio} = 0.19552$$

Status: **PASS**
Ratio: **0.200**