

Project Name: MTSOLAR_1G9LFB9K0EE19 **Date:** Mon Nov 10 2025
Location: 37370 US Hwy 285, Tres Piedras, NM 87577, USA **Number of Modules:** 15
Unique ID: 1P-0-6TOP-SD-45-L-5Hx3W-L868 **Number of Poles:** 1
Dealer: _____ **Date Sold:** _____

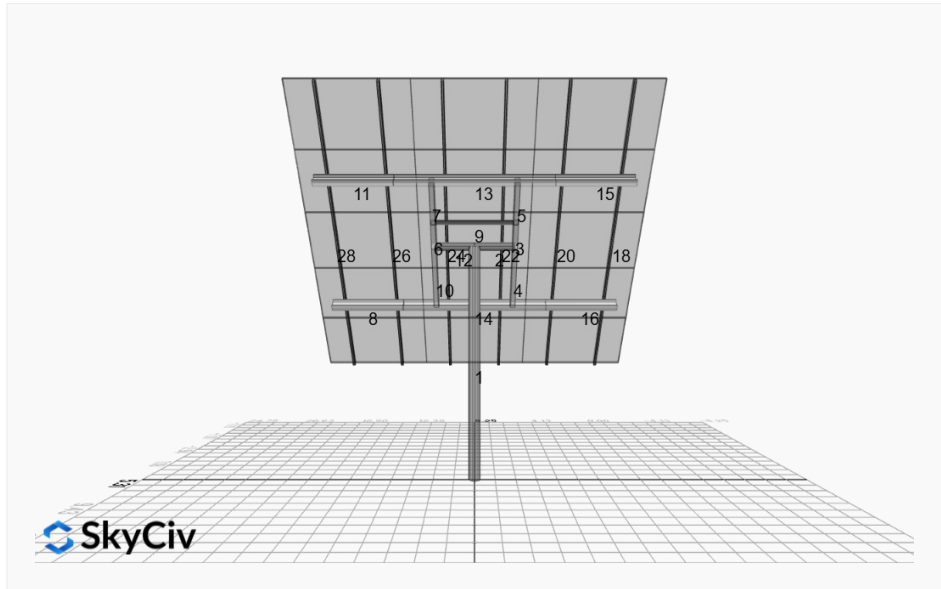

Array Dimensions N/S	16.88 ft
Array Dimensions E/W	16.50 ft
Winter Tilt Angle (Degrees)	51
Front Edge Clearance	5

MT Solar Bill of Materials (1P-0-6TOP-SD-45-L-5Hx3W-L868)

Part	Short Description	BOM Qty
MTS-PC-6	6IN Pole Cap Assembly	1
MTS-HF-SD	H-Frame Assembly-SD	1
MTS-SD-Wing-45	45IN SD Wing	4
MTS-CLAMP-ANGLE-4PK	Angle Clamp	3

Rail Bill of Materials

Part	Qty
Rails (203in Long)	6x
Rail Attachment	24x
Module Mid Clamp	24x
Module End Clamp	12x
Ground Lug	3x

Site Details:



Site Address: 37370 US Hwy 285, Tres Piedras, NM 87577, USA

Array Specifications

Duty Classification:	SD
Module Width:	40.00 in
Module Length:	65.00 in
Number of Rows:	5
Number of Columns:	3
Total Number of Modules:	15
Winter Tilt Angle:	51
Front Edge Clearance:	5
Total Array Height at Tilt:	18.11 ft
Total Frame Length:	15.00 ft
Module Info/Notes:	
Array Dimensions N/S:	16.88 ft
Array Dimensions E/W:	16.50 ft
Rail Length:	202.50 in
Rail Spacing:	2.75 ft

Support Specifications

Pole Size:	6in Pipe Sch 80
Pole Length above Grade:	11.56 ft
Number of Poles:	1
Pole Spacing:	0

Foundation Specifications

Foundation Type:	round
Foundation Dimensions:	36 in dia.
Foundation Depth (below grade):	9.5 ft
Foundation Volume:	67.15 ft ³

Site Info

Risk Category:	I
Exposure:	C
Soil Classification:	sand
Site Location:	37370 US Hwy 285, Tres Piedras, NM 87577, USA
Wind Speed:	115 mph

Snow Load:

50 psf

Design Disclaimer

This software should be used for preliminary designs and should not be used as a final design unless reviewed, verified and designed by a qualified structural engineer.

AutoDesigner Input

```
{ "product_type": "Beam", "designer_name": "Justin Broderick", "designer_email": "justin.c.broderick81@gmail.com", "designer_phone": "2536770200", "project_id": "MTSOLAR_1G9LFB9K0EE19", "site_address": "37370 US Hwy 285, Tres Piedras, NM 87577, USA", "module_info": "", "module_width": 40, "module_length": 65, "number_rows": 5, "number_columns": 3, "pole_mount_section": "4_40", "core_pipe_width": 65, "core_pipe_section": "2_40", "adjuster_section": "2_40", "core_beam_height": 65, "core_beam_section": "HSS3x2x1/8", "main_pipe_section": "2_12GA", "pole_spacing": "15", "tilt_angle": 51, "ground_clearance": 5, "risk_category": "I", "exposure_category": "C", "frame_duty_override": "auto", "pole_override": "auto", "soil_type": "sand", "customer_foundation_override": "36_Round", "foundation_type": "Round", "foundation_size": 36, "check_rails": false, "wind_speed_override": 115, "snow_load_override": 50, "direct_snow_load": false, "add_angle_brace": false }
```

Design Notes:

- Deflection checks are set to L/1 due to manufacturer structural design intent
- Foundation Soil Parameters used in this Autodesign are all estimates, proper geotechnical reports are required to confirm soil profiles
- Wind speeds, snow loads and other site specific results are based on ASCE 7-16
- Steel frame design checks are based on AISC 360-16 LRFD
- Design / analysis of fixings and connections are not carried out by this module.
- Impacts of eccentrically applied, partial or pattern loading are not considered by this module.
- Foundation Design and Sizing is approximate only

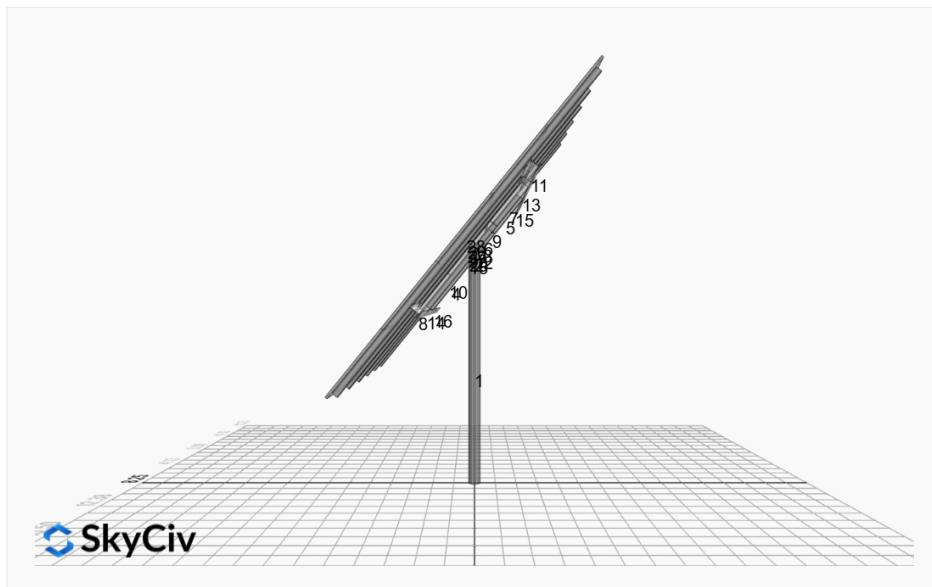
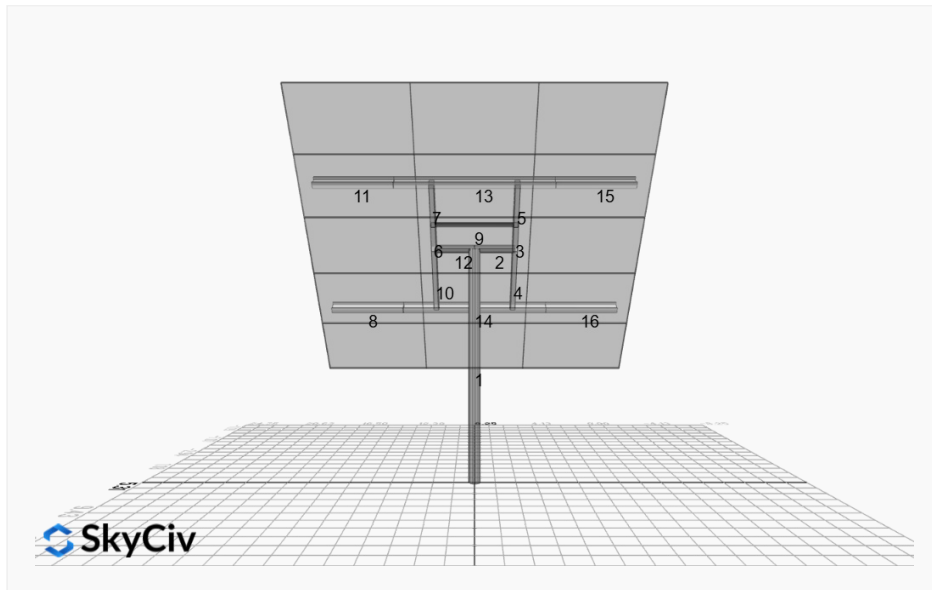

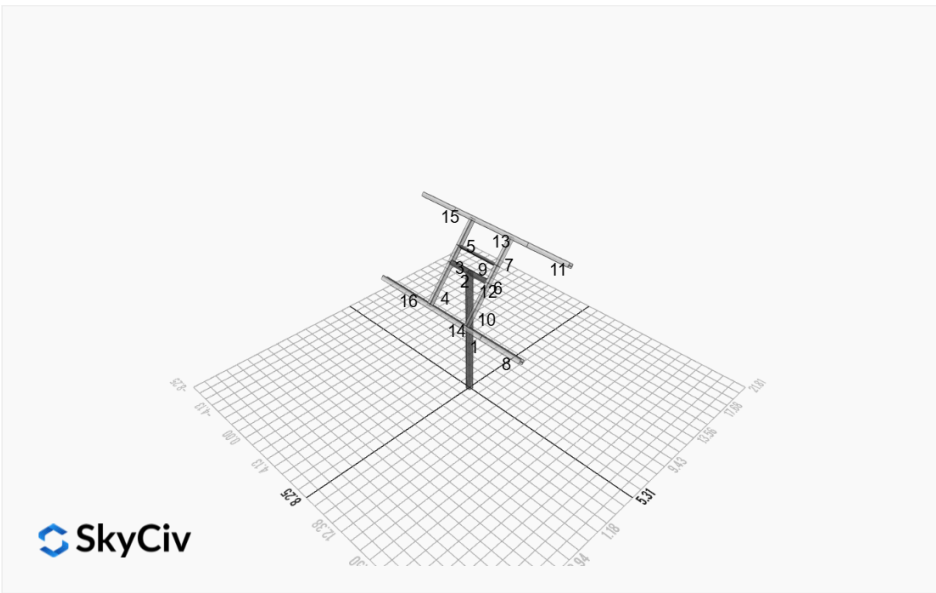
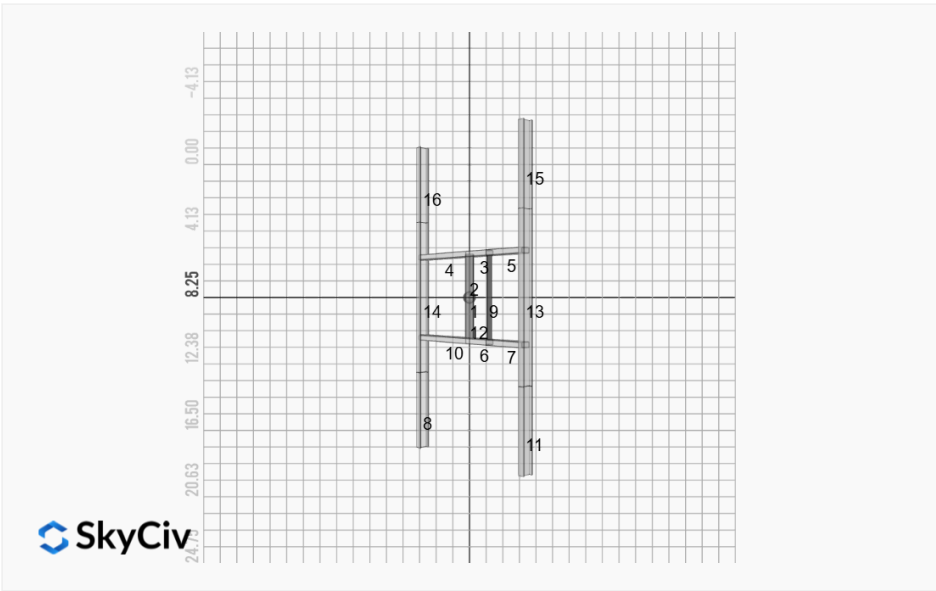

FEM Results (Envelope Worst Case)

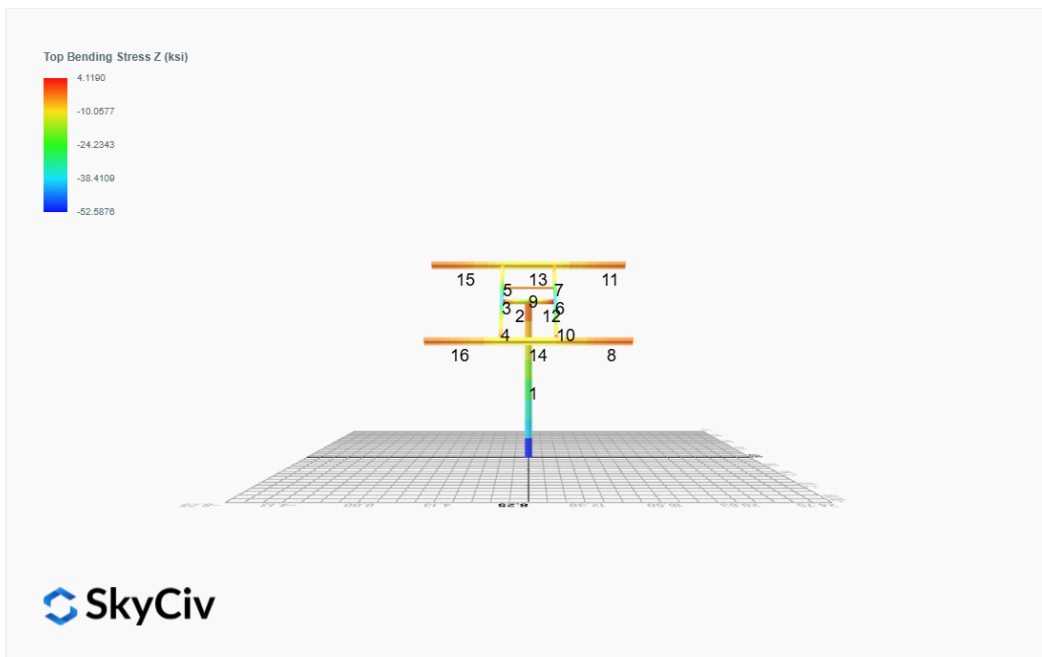
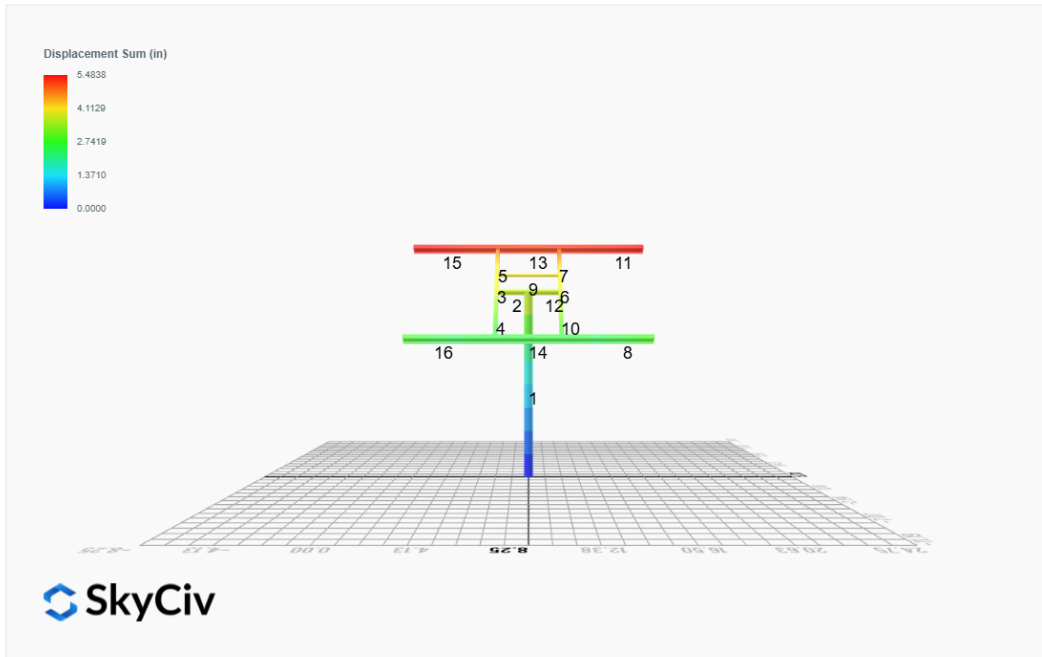

Top Bending Stress Y (ksi)

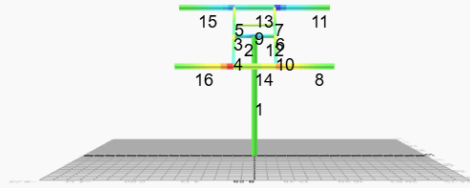

Shear Stress Y (ksi)

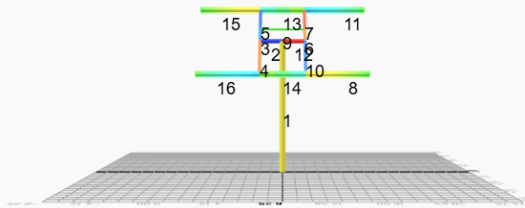

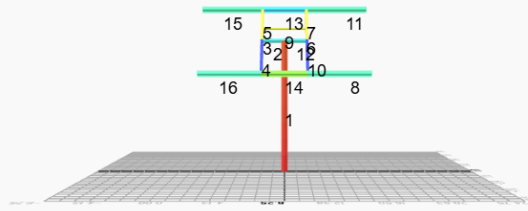

Reaction Forces for Foundation 1 (Node ID#1), (kip, kip-ft)

LRFD Load Combination Results

Name	Fx	Fy	Fz	Mx	My	Mz
ULS: 1. 1.4D	0.0000	2.8645	0.0000	0.0000	-0.0000	0.0279
ULS: 2. 1.2D + 1.6L + 0.5(S or Lr or R)	0.0000	3.3705	0.0000	0.0000	-0.0000	0.0308
ULS: 2. 1.2D + 1.6L + 0.5(S or Lr or R)	0.0000	2.4552	0.0000	0.0000	-0.0000	0.0227
ULS: 3. 1.2D + 1.6(S or Lr or R) + L	0.0000	5.3841	0.0000	0.0000	-0.0000	0.0600
ULS: 5. 1.2D + E + L + 0.2S	0.0000	2.8214	0.0000	0.0000	-0.0000	0.0256
ULS: 7. 0.9D + 1.0E	0.0000	1.8414	0.0000	0.0000	-0.0000	0.0157
ULS: 4. 1.2D + W + L + 0.5(S or Lr or R)_Wind downforce Case A only	-4.4503	6.9743	0.0000	0.0000	0.0000	53.5675
ULS: 4. 1.2D + W + L + 0.5(S or Lr or R)_Wind downforce Case B only	0.0000	3.3705	0.0000	0.0000	-0.0000	0.0308
ULS: 4. 1.2D + W + L + 0.5(S or Lr or R)_Wind uplift Case A only	4.4503	-0.2333	0.0000	-0.0000	-0.0000	-51.3850
ULS: 4. 1.2D + W + L + 0.5(S or Lr or R)_Wind uplift Case B only	0.0000	3.3705	0.0000	0.0000	-0.0000	0.0308
ULS: 4. 1.2D + W + L + 0.5(S or Lr or R)_Wind downforce Case A only	-4.4503	6.0591	0.0000	0.0000	0.0000	53.2623
ULS: 4. 1.2D + W + L + 0.5(S or Lr or R)_Wind downforce Case B only	0.0000	2.4552	0.0000	0.0000	-0.0000	0.0227
ULS: 4. 1.2D + W + L + 0.5(S or Lr or R)_Wind uplift Case A only	4.4503	-1.1486	0.0000	-0.0000	-0.0000	-51.1229
ULS: 4. 1.2D + W + L + 0.5(S or Lr or R)_Wind uplift Case B only	0.0000	2.4552	0.0000	0.0000	-0.0000	0.0227
ULS: 3. 1.2D + 1.6(S or Lr or R) + 0.5W_Wind downforce Case A only	-2.2252	7.1860	0.0000	0.0000	0.0000	26.8795
ULS: 3. 1.2D + 1.6(S or Lr or R) + 0.5W_Wind downforce Case B only	0.0000	5.3841	0.0000	0.0000	-0.0000	0.0600
ULS: 3. 1.2D + 1.6(S or Lr or R) + 0.5W_Wind uplift Case A only	2.2252	3.5822	0.0000	-0.0000	-0.0000	-26.2142
ULS: 3. 1.2D + 1.6(S or Lr or R) + 0.5W_Wind uplift Case B only	0.0000	5.3841	0.0000	0.0000	-0.0000	0.0600
ULS: 3. 1.2D + 1.6(S or Lr or R) + 0.5W_Wind downforce Case A only	-2.2252	4.2572	0.0000	0.0000	0.0000	26.3712
ULS: 3. 1.2D + 1.6(S or Lr or R) + 0.5W_Wind downforce Case B only	0.0000	2.4552	0.0000	0.0000	-0.0000	0.0227
ULS: 3. 1.2D + 1.6(S or Lr or R) + 0.5W_Wind uplift Case A only	2.2252	0.6533	0.0000	-0.0000	-0.0000	-25.8025
ULS: 3. 1.2D + 1.6(S or Lr or R) + 0.5W_Wind uplift Case B only	0.0000	2.4552	0.0000	0.0000	-0.0000	0.0227
ULS: 6. 0.9D + 1.0W_Wind downforce Case A only	-4.4503	5.4452	0.0000	0.0000	0.0000	53.0603
ULS: 6. 0.9D + 1.0W_Wind downforce Case B only	0.0000	1.8414	0.0000	0.0000	-0.0000	0.0157
ULS: 6. 0.9D + 1.0W_Wind uplift Case A only	4.4503	-1.7624	0.0000	-0.0000	-0.0000	-50.9524
ULS: 6. 0.9D + 1.0W_Wind uplift Case B only	0.0000	1.8414	0.0000	0.0000	-0.0000	0.0157

ASD Load Combination Results

Name	Fx	Fy	Fz	Mx	My	Mz
ULS: 1. D	0.0000	2.0460	0.0000	0.0000	-0.0000	0.0179
ULS: 2. D + L	0.0000	2.0460	0.0000	0.0000	-0.0000	0.0179
ULS: 3. D + (S or Lr or R)	0.0000	3.8766	0.0000	0.0000	-0.0000	0.0351
ULS: 3. D + (S or Lr or R)	0.0000	2.0460	0.0000	0.0000	-0.0000	0.0179
ULS: 4. D + 0.75L + 0.75(S or Lr or R)	0.0000	3.4189	0.0000	0.0000	-0.0000	0.0296
ULS: 4. D + 0.75L + 0.75(S or Lr or R)	0.0000	2.0460	0.0000	0.0000	-0.0000	0.0179
ULS: 5b. D + 0.7E	0.0000	2.0460	0.0000	0.0000	-0.0000	0.0179
ULS: 6b. D + 0.75L + 0.75(0.7)E + 0.75S	0.0000	3.4189	0.0000	0.0000	-0.0000	0.0296
ULS: 8. 0.6D + 0.7E	0.0000	1.2276	0.0000	0.0000	-0.0000	0.0096
ULS: 5a. D + 0.6W_Wind downforce Case A only	-2.6702	4.2083	0.0000	0.0000	0.0000	31.6240
ULS: 5a. D + 0.6W_Wind downforce Case B only	0.0000	2.0460	0.0000	0.0000	-0.0000	0.0179
ULS: 5a. D + 0.6W_Wind uplift Case A only	2.6702	-0.1162	0.0000	-0.0000	-0.0000	-30.8388
ULS: 5a. D + 0.6W_Wind uplift Case B only	0.0000	2.0460	0.0000	0.0000	-0.0000	0.0179
ULS: 6a. D + 0.75L + 0.75(0.6)W + 0.75(S or Lr or R)_Wind downforce Case A only	-2.0026	5.0406	0.0000	0.0000	0.0000	23.8569
ULS: 6a. D + 0.75L + 0.75(0.6)W + 0.75(S or Lr or R)_Wind downforce Case B only	0.0000	3.4189	0.0000	0.0000	-0.0000	0.0296
ULS: 6a. D + 0.75L + 0.75(0.6)W + 0.75(S or Lr or R)_Wind uplift Case A only	2.0026	1.7972	0.0000	-0.0000	-0.0000	-23.3681
ULS: 6a. D + 0.75L + 0.75(0.6)W + 0.75(S or Lr or R)_Wind uplift Case B only	0.0000	3.4189	0.0000	0.0000	-0.0000	0.0296

Name	Fx	Fy	Fz	Mx	My	Mz
ULS: 6a. D + 0.75L + 0.75(0.6)W + 0.75(S or Lr or R)_Wind downforce Case A only	-2.0026	3.6678	0.0000	0.0000	0.0000	23.6504
ULS: 6a. D + 0.75L + 0.75(0.6)W + 0.75(S or Lr or R)_Wind downforce Case B only	0.0000	2.0460	0.0000	0.0000	-0.0000	0.0179
ULS: 6a. D + 0.75L + 0.75(0.6)W + 0.75(S or Lr or R)_Wind uplift Case A only	2.0026	0.4243	0.0000	-0.0000	-0.0000	-23.1931
ULS: 6a. D + 0.75L + 0.75(0.6)W + 0.75(S or Lr or R)_Wind uplift Case B only	0.0000	2.0460	0.0000	0.0000	-0.0000	0.0179
ULS: 7. 0.6D + 0.6W_Wind downforce Case A only	-2.6702	3.3899	0.0000	0.0000	0.0000	31.4637
ULS: 7. 0.6D + 0.6W_Wind downforce Case B only	0.0000	1.2276	0.0000	0.0000	-0.0000	0.0096
ULS: 7. 0.6D + 0.6W_Wind uplift Case A only	2.6702	-0.9347	0.0000	-0.0000	-0.0000	-30.7035
ULS: 7. 0.6D + 0.6W_Wind uplift Case B only	0.0000	1.2276	0.0000	0.0000	-0.0000	0.0096

Worst Case Reactions (LRFD)

Note: Downforce / downwind wind load cases are assumed to govern.

Result	Value (kip, kip-ft)
Axial	7.1860
Shear X	-4.4503
Shear Z	0.0000
Moment X	0.0000
Moment Y (Twist)	0.0000
Moment Z	53.5675

Worst Case Reactions (ASD)

Note: Downforce / downwind wind load cases are assumed to govern.

Result	Value (kip, kip-ft)
Axial	5.0406
Shear X	-2.6702
Shear Z	0.0000
Moment X	0.0000
Moment Y (Twist)	0.0000
Moment Z	31.6240

Project Details

Design Code: AISC 360-16 LRFD
 Provision: LRFD
 Country: United States

 User Name: sales@mtsolar.us
 Project Name: MTSOLAR_1G9LFB9K0EE19
 Unit System: imperial



Design Input Information

Design Factors			
Φ_t	Φ_c	Φ_b	Φ_v
0.9	0.9	0.9	0.9

Design Materials			
ID	E (ksi)	F_y (ksi)	F_u (ksi)
1	29000	50	65
2	29000	46	62
4	29000	50	62

Section Dimensions

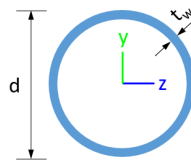

ID	Name	d (in)	t_w (in)				
1	2in Pipe Sch 40	2.38	0.15				
4	4in Pipe Sch 40	4.50	0.24				
8	6in Pipe Sch 80	6.63	0.43				

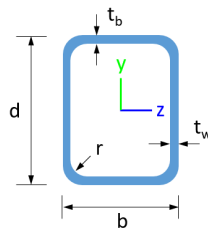

ID	Name	d (in)	b (in)	t_w (in)	t_b (in)	r (in)	
15	HSS5x3x1/8	5.00	3.00	0.12	0.12	0.12	

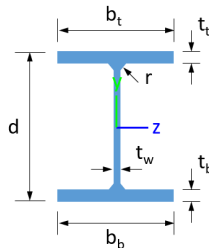

ID	Name	d (in)	t_w (in)	b_t (in)	b_b (in)	t_t (in)	t_b (in)	r (in)
18	W6x9	5.90	0.17	3.94	3.94	0.21	0.21	0.25

3	79.65	74.89	10.99	6.26	29.14	16.61
4	79.65	72.84	10.99	6.26	29.14	16.61
5	79.65	74.30	10.99	6.26	29.14	16.61
6	79.65	74.89	10.99	6.26	29.14	16.61
7	79.65	74.30	10.99	6.26	29.14	16.61
8	120.60	54.44	23.36	6.45	30.09	45.74
9	44.49	40.02	2.63	2.63	13.35	13.35
10	79.65	72.84	10.99	6.26	29.14	16.61
11	120.60	54.44	23.36	6.45	30.09	45.74
12	131.41	130.46	14.87	14.87	39.42	39.42
13	120.60	84.03	18.35	6.45	30.09	45.74
14	120.60	84.03	18.33	6.45	30.09	45.74
15	120.60	54.44	23.36	6.45	30.09	45.74
16	120.60	54.44	23.36	6.45	30.09	45.74

Design Ratio

Member ID	P	M _z	M _y	V _y	V _z	(P,M _z ,M _y)	Worst LC	KL/r	δ	Status
1	0.023	0.936	0.000	0.043	0.000	0.947	#13	0.205	Not Required	Pass
2	0.003	0.366	0.302	0.086	0.056	0.669	#13	0.034	Not Required	Pass
3	0.013	0.651	0.094	0.065	0.014	0.711	#13	0.044	Not Required	Pass
4	0.012	0.648	0.207	0.065	0.035	0.736	#13	0.078	Not Required	Pass
5	0.013	0.404	0.214	0.065	0.042	0.435	#13	0.073	Not Required	Pass
6	0.013	0.651	0.094	0.065	0.014	0.711	#13	0.044	Not Required	Pass
7	0.013	0.404	0.214	0.065	0.042	0.435	#13	0.073	Not Required	Pass
8	0.000	0.075	0.136	0.031	0.010	0.195	#21	Not Required	Not Required	Pass
9	0.012	0.046	0.067	0.001	0.000	0.116	#13	0.198	Not Required	Pass
10	0.012	0.648	0.207	0.065	0.035	0.736	#13	0.078	Not Required	Pass
11	0.000	0.075	0.136	0.031	0.010	0.195	#21	Not Required	Not Required	Pass
12	0.003	0.366	0.302	0.086	0.056	0.669	#13	0.034	Not Required	Pass
13	0.006	0.216	0.292	0.046	0.015	0.454	#21	0.177	Not Required	Pass
14	0.007	0.220	0.292	0.046	0.015	0.454	#21	0.177	Not Required	Pass
15	0.000	0.075	0.136	0.031	0.010	0.195	#21	Not Required	Not Required	Pass
16	0.000	0.075	0.136	0.031	0.010	0.195	#21	Not Required	Not Required	Pass

Definitions

Φ_t	Safety factor for tensile
Φ_c	Safety factor for compression
Φ_b	Safety factor for flexure
Φ_v	Safety factor for shear
E	Modulus of elasticity
F _y	Specified minimum yield stress
F _u	Specified minimum tensile strength
A	Cross-sectional area
J	Torsional constant
I _{yp}	Moment of inertia about the Y axes
I _{zp}	Moment of inertia about the Z axes
I _w	Warping constant
S _{yp}	Plastic section modulus about the Y axis
S _{zp}	Plastic section modulus about the Z axis
KL	Effective length
C _b	Buckling modification factor (from all load combinations)
L _b	Length between braced points
LST	Limited slenderness for tension

LSC	Limited slenderness for compression
LD	Limited deflection
P_n	Nominal axial strength (tension/compression)
M_n	Nominal flexural strength (about Z/Y axis)
V_n	Nominal shear strength (along Z/Y axis)
P	Design ratio in case of axial force
M_z	Design ratio in case of bending about Z axis
M_y	Design ratio in case of bending about Y axis
V_y	Design ratio in case of shear along Y axis
V_z	Design ratio in case of shear along Z axis
(P, M_z, M_y)	Design ratio in case of axial force and bending action
KL/r	Design ratio in case of section slenderness
δ	Design ratio in case of member deflection
OK	Capacity is provided
NG	Capacity is not provided

IBC 2018 Pile Design



Input	Description
Region	American Standard
Concrete design code	American Concrete Institute (ACI 318:2019)

Cross-section

Input	Description	Value
Shape	Cross-sectional shape	Round
D	Section diameter	36 in

Material Properties

Input	Description	Value
f'_{ck}	Concrete compressive strength	2.5 ksi
f_{yk}	Yield strength of steel	60 ksi
d_b	Rebar diameter	#5 (0.625) in
cover	Concrete cover	3 in

Soil Parameters (IBC 1806)

Input	Description	Value
Soil type	Sand, silty sand, clayey sand, silty gravel & clayey gravel	
q_a	Allowable bearing pressure	2000 psf
R	Allowable lateral pressure	150 psf/ft

Loading

Load	ASD	LRFD
P	5.041 kip	7.186 kip
V _x	-2.67 kip	-4.45 kip
V _z	0 kip	0 kip
M _x	0 kip-ft	0 kip-ft
M _z	31.62 kip-ft	53.57 kip-ft

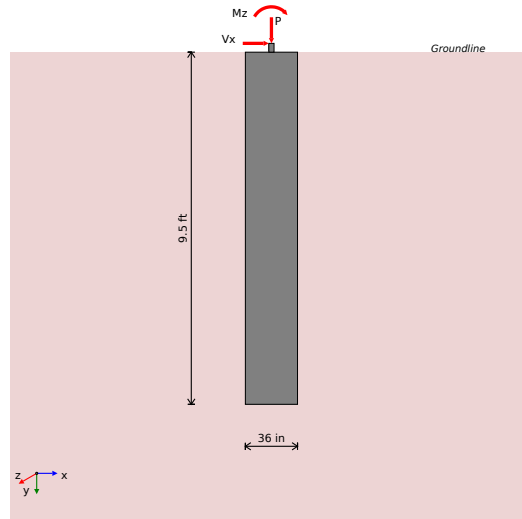

Required depth to resist lateral loads (ASD)

Allowable lateral pressure

$$R = 150 \text{ psf/ft}$$

Point of application of lateral load:

$$H = h_1 + h_2 + h_e = 0 + 0 + 0 = 0 \text{ ft}$$

Considering x-direction:

Lateral force per section length

$$H_o = \frac{V_x}{D} = \frac{-2.67}{36} = -0.074 \text{ kip/ft}$$

Moment per section length

$$M = \frac{M_z + (V_x \times H)}{L} = \frac{31.62 + (-2.67 \times 0)}{9.5} = 3.33 \text{ kip-ft}$$

$$D = 36 \text{ ft}$$

Required depth of embedment in earth:

$$L_z^3 - \left(14.14 \times \frac{H_o \times L_z}{R}\right) - \left(18.85 \times \frac{M_o}{R}\right) = 0$$

Solving the cubic equation:

$$L_{e,z} = 8.491 \text{ ft}$$

Considering z-direction:

Since there are no loads applied in this direction, the required effective length: $L_{e,z} = 0 \text{ ft}$.

Minimum embedded depth

Depth of pile required

$$L_{e,req} = \text{MAX}[L_{e,x}, L_{e,z}] = \text{MAX}[8.491, 0] = 8.491 \text{ ft}$$

Actual embedded length

$$L_e = L - h_2 - h_c = 9.5 - 0 - 0 = 9.5 \text{ ft}$$

Utilisation

$$\text{Ratio} = \frac{L_{e,req}}{L_e} = \frac{8.491}{9.5} = 0.894$$

UTILITY: 0.89

REFERENCES

CALCULATIONS

RESULTS

End-bearing Capacity (ASD)

Allowable bearing pressure
Unit weight of concrete

$q_a = 2000 \text{ psf}$
 $w_c = 0.15 \text{ kip/ft}^3$

Cross-sectional area:

$$A = \frac{\pi \times D^2}{4} = \frac{\pi \times 36^2}{4} = 7.069 \text{ ft}^2$$

End-bearing pressure:

$$q = \frac{P}{A} = \frac{5.041}{7.069} = 713.1 \text{ psf}$$

Utilisation

$$\text{Ratio} = \frac{q}{q_a} = \frac{713.1}{2000} = 0.357$$

UTILITY: 0.36

Lateral Soil Pressure (ASD)

Allowable lateral pressure

$R = 150 \text{ psf/ft}$

Length to least lateral dimension ratio:

$$\frac{L}{D} = \frac{9.5}{3} = 3.167$$

$L/D \text{ ratio} \leq 10$. This pile is classified as a short pile.

Considering x-direction:

Distance from resting surface to pivot point:

$$a = \frac{(4 \times M_o \times L_e) + (3 \times H_o \times L_e^2)}{(6 \times M_o) + (4 \times H_o \times L_e)}$$

$$a = \frac{(4 \times 10.54 \times 9.5) + (3 \times 0.89 \times 9.5^2)}{(6 \times 10.54) + (4 \times 0.89 \times 9.5)} = 6.609 \text{ ft}$$

Earth pressure against the pile at a distance $a/2$ from the resting surface:

$$p = \frac{1.178 \times [(4 \times M_o) + (3 \times H_o \times L_e)]^2}{L_e^2 \times [(3 \times M_o) + (2 \times H_o \times L_e)]}$$

$$p = \frac{1.178 \times [(4 \times 10.54) + (3 \times -0.89 \times 9.5)]^2}{9.5^2 \times [(3 \times 10.54) + (2 \times -0.89 \times 9.5)]} = 0.25 \frac{\text{kip}}{\text{ft}^2}$$

Allowable lateral soil pressure at a depth of $a/2$:

$$p_a = R \times \frac{a}{2} = 0.15 \times \frac{6.609}{2} = 0.496 \frac{\text{kip}}{\text{ft}^2}$$

Utilisation - pressure at a depth of a/2

$$\text{Ratio} = \frac{p}{p_a} = \frac{0.25}{0.496} = 0.505$$

UTILITY: 0.51

Earth pressure against the pile at distance L_e :

$$s = \frac{9.425 \times [(2 \times M_o) + (H_o \times L_e)]}{L_e^2} = \frac{9.425 \times [(2 \times 10.54) + (-0.89 \times 9.5)]}{9.5^2} = 1.319 \frac{\text{kip}}{\text{ft}^2}$$

Allowable lateral soil pressure at a depth of L_e :

$$p_s = R \times L_e = 0.15 \times 9.5 = 1.425 \frac{\text{kip}}{\text{ft}^2}$$

Utilisation - pressure at a depth of L_e

$$\text{Ratio} = \frac{s}{p_s} = \frac{1.319}{1.425} = 0.925$$

UTILITY: 0.93

Considering z-direction:

Since no loads are applied in this direction, lateral soil pressure check is not required.

REFERENCES

CALCULATIONS

RESULTS

Shear force and bending moment (LRFD)

Considering x-direction:

Lateral force per section length

$$H_o = \frac{V_x}{D} = \frac{-4.45}{36} = -1.483 \frac{\text{kip}}{\text{ft}}$$

Moment per section length

$$M_o = \frac{M_z + (V_x \times H)}{D} = \frac{53.57 + (-4.45 \times 0)}{36} = 17.86 \frac{\text{kip-ft}}{\text{ft}}$$

Distance from resting surface to pivot point:

$$a = \frac{(4 \times M_o \times L_e) + (3 \times H_o \times L_e^2)}{(6 \times M_o) + (4 \times H_o \times L_e)}$$

$$a = \frac{(4 \times 17.86 \times 9.5) + (3 \times 1.483 \times 9.5^2)}{(6 \times 17.86) + (4 \times 1.483 \times 9.5)} = 6.606 \text{ ft}$$

Max shear force located at depth a:

$$E = \frac{M_o}{H_o} = \frac{17.86}{-1.483} = 12.04 \text{ ft}$$

$$V_{max,x} = (H_o \times D) \times [1 - [3 \times \left(\frac{4 \times E}{L_e} + 3\right) \times \left(\frac{a}{L_e}\right)^2] + [4 \times \left(\frac{3 \times E}{L_e} + 2\right) \times \left(\frac{a}{L_e}\right)^3]$$

$$V_{max,x} = (-1.483 \times 36) \times [1 - [3 \times \left(\frac{4 \times 12.04}{9.5} + 3\right) \times \left(\frac{6.606}{9.5}\right)^2] + [4 \times \left(\frac{3 \times 12.04}{9.5} + 2\right) \times \left(\frac{6.606}{9.5}\right)^3]$$

$$V_{max,x} = 12.91 \text{ kip}$$

Max bending moment located at a depth of a/2:

$$M_{max,x} = (H_o \times D \times L_e) \times \left[\left(\frac{E}{L_e} + \frac{a}{2 \times L_e} \right) - \left[\left(\frac{4 \times E}{L_e} + 3 \right) \times \left(\frac{a}{2 \times L_e} \right)^3 \right] + \left[\left(\frac{3 \times E}{L_e} + 2 \right) \times \left(\frac{a}{2 \times L_e} \right)^4 \right] \right]$$

$$M_{max,x} = (-1.483 \times 36 \times 9.5) \times \left[\left(\frac{12.04}{9.5} + \frac{6.606}{2 \times 9.5} \right) - \left[\left(\frac{4 \times 12.04}{9.5} + 3 \right) \times \left(\frac{6.606}{2 \times 9.5} \right)^3 \right] + \left[\left(\frac{3 \times 12.04}{9.5} + 2 \right) \times \left(\frac{6.606}{2 \times 9.5} \right)^4 \right] \right]$$

$$M_{max,x} = 57.51 \text{ kip-ft}$$

Considering z-direction:

There are no loads applied in this direction.

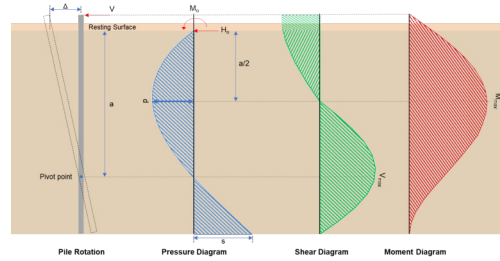

Minimum Reinforcement Check (LRFD)

Gross area of concrete:

$$A_g = \frac{\pi \times D^2}{4} = \frac{\pi \times 36^2}{4} = 1018 \text{ in}^2$$

Main Reinforcement

22.4.2.2 Required reinforcement:

$$A_{st,req} = \frac{P - (0.85 \times f'_{ck} \times A_g)}{f_{yk} - (0.85 \times f'_{ck})} = \frac{7.186 - (0.85 \times 2.5 \times 1018)}{60 - (0.85 \times 2.5)} = -37.25 \text{ in}^2$$

10.6.1.1 Maximum reinforcement:

$$A_{st,max} = 0.08 \times A_g = 0.08 \times 1018 = 81.43 \text{ in}^2$$

7.6.1.1 Minimum reinforcement:

$$A_{st,min} = 0.0018 \times A_g = 0.0018 \times 1018 = 1.832 \text{ in}^2$$

Governing minimum reinforcement area:

$$(0.0018 \times A_g) \leq A_{st,req} \leq (0.08 \times A_g)$$

$$A_{min} = 1.832 \text{ in}^2$$

Minimum number of reinforcements:

$$A_{bar} = 0.307 \text{ in}^2$$

$$n_{min} = \frac{A_{min}}{A_{bar}} = \frac{1.832}{0.307} = 6$$

25.2.3 Minimum spacing:

$$s_{rebar} = \text{MAX}[1.5, 1.5 \times d_b] = \text{MAX}[1.5, (1.5 \times 0.625)] = 1.5 \text{ in}$$

Use: $n = 6$ pcs at 1.5 in minimum spacing

Total reinforcement area:

$$A_{st} = 6 \times 0.307 = 1.841 \text{ in}^2$$

Shear Reinforcement

25.7.2.2 For main reinforcement ≤ 1.41 in: Use #3(0.375 in)

Maximum spacing of shear Reinforcements:

$$s = \text{MIN}[16 \times d_b, 48 \times d_{b,ties}, D] = \text{MIN}[(16 \times 0.625), (48 \times 0.375), 36] = 10 \text{ in}$$

Detailing Summary

Main reinforcement	#5 (0.625 in) - 6pcs at 1.5 in min. spacing
Shear reinforcement	#3 (0.375 in) at 10 in max. spacing

Axial Compression Strength (LRFD)

22.4.2.2 Allowable axial compressive strength:

$$\phi P_N = \phi \times 0.85 \times [(0.85 \times f'_{ck} \times [A_g - A_{st}]) + (f_{yk} \times A_{st})]$$

$$\phi P_N = 0.65 \times 0.85 \times [(0.85 \times 2.5 \times [1018 - 1.841]) + (60 \times 1.841)] = 1254 \text{ kip}$$

Utilisation

$$\text{Ratio} = \frac{P}{\phi P_N} = \frac{7.186}{1254} = 0.006$$

Shear Strength LRFD

Effective shear width	$b_w = 36$ in
Effective shear depth	$d = 28.8$ in
Shear reinforcement area	$A_v = 0.221$ in ²
Shear reinforcement spacing	$s = 10$ in
Concrete type factor (Normal concrete)	$\lambda = 1$
Strength reduction factor for shear	$\phi = 0.75$
Maximum shear in the x-direction	$V_{max,x} = 12.91$ kip
Maximum shear in the z-direction	$V_{max,z} = 0$ kip

22.5.5.1.1 Max shear strength of concrete:

$$V_{c,max} = 5 \times \lambda \times \sqrt{f'_{ck}} \times b_w \times d = 5 \times 1 \times \sqrt{2.5} \times 36 \times 28.8 = 259.2 \text{ kip}$$

Table 22.5.5.1 Shear strength of concrete:

$$V_{c,a} = \left(2 \times \lambda \times \sqrt{f'_{ck}} + \text{MIN} \left[\frac{P}{6 \times A_g}, (0.05 \times f'_{ck}) \right] \right) \times (b_w \times d)$$

$$V_{c,a} = \left(2 \times 1 \times \sqrt{2.5} + \text{MIN} \left[\frac{7.186}{6 \times 1018}, (0.05 \times 2.5) \right] \right) \times (36 \times 28.8) = 104.9 \text{ kip}$$

Governing shear strength of concrete:

$$V_c = \text{MIN}[V_{c,max}, V_{c,a}] = \text{MIN}[259.2, 104.9] = 104.9 \text{ kip}$$

22.5.1.2 Shear strength of steel (a):

$$V_{s,a} = 8 \times \sqrt{f'_{ck}} \times b_w \times d = 8 \times \sqrt{2.5} \times 36 \times 28.8 = 414.7 \text{ kip}$$

22.5.8.5.3 Shear strength of steel (b):

$$V_{s,b} = \frac{A_v \times f_{yk} \times d}{s} = \frac{0.221 \times 60 \times 28.8}{10} = 38.17 \text{ kip}$$

Governing shear strength of steel:

$$V_s = \text{MIN}[V_{s,a}, V_{s,b}] = \text{MIN}[414.7, 38.17] = 38.17 \text{ kip}$$

22.5.1.1 Allowable shear strength:

$$\phi V_n = \phi \times (V_c + V_s) = 0.75 \times (104.9 + 38.17) = 107.3 \text{ kip}$$

$$V_{max} = \text{MAX}[12.91, 0] = 12.91 \text{ kip}$$

Utilisation

$$\text{Ratio} = \frac{V_{max}}{\phi V_n} = \frac{12.91}{107.3} = 0.12$$

Flexural Strength (LRFD)

Concrete type factor (Normal concrete)	$\lambda = 1$
Strength reduction factor for flexure	$\phi = 0.65$
Modulus of steel reinforcement	$E_s = 200 \times 3$ ksi
Maximum concrete strain	$\epsilon_c = 0.0030$
Yield strain of steel f_y/E_s	$\epsilon_y = 0.0003$
Section width	$b = 36$ in
Distance to the compression rebar	$d_c = 3.688$ in
Distance to the tension rebar	$d = 28.8$ in
Total bar area	$A_s = 1.841$ in ²
Maximum applied axial load	$P = 7.186$ kip
Maximum moment in the x-direction	$M_{max,x} = 57.51$ kip-ft
Maximum moment in the z-direction	$M_{max,z} = 0$ kip-ft

Compressive force due to concrete:

$$\beta_1 = 0.85$$

$$C_{rc} = \beta_1 \times f'_c \times A_c$$

$$A_c = \frac{b^2}{8} \times (\theta - \sin\theta)$$

θ = Central angle of the compressive area in radians

Compressive force due to bars in compression:

$$C_{rs} = f_1 \times A_{sc}$$

$$\epsilon_1 = (c - d_s) \times \frac{\epsilon_c}{c}$$

$$f_1 = E_s \times \epsilon_1 \quad (\epsilon_1 < \epsilon_{sy}), f_1 = f_y \quad (\epsilon_1 \geq \epsilon_{sy})$$

Tensile force due to bars in tension:

$$T_{rs} = f_2 \times A_{st}$$

$$\epsilon_2 = (d - c) \times \frac{\epsilon_{cu}}{c}$$

$$f_2 = E_s \times \epsilon_2 \quad (\epsilon_2 < \epsilon_{sy}), f_2 = \phi_c \times f_y \quad (\epsilon_2 \geq \epsilon_{sy})$$

Interaction Diagram Summary

Point	Case	M _r	P _r
P1	Pure Tension	0	-99.4
P2	Pure Bending	131.5	0
P3	Balanced Failure	474.1	1108
P4	Decompression	419.7	1230
P5	Compression Limit	398.3	1254
P6	Pure Compression	0	1254

Uniaxial Bending Check

$$M_f = \sqrt{M_{max,x}^2 + M_{max,z}^2} = \sqrt{57.51^2 + 0^2} = 57.51 \text{ kip-ft}$$

Interaction Diagram

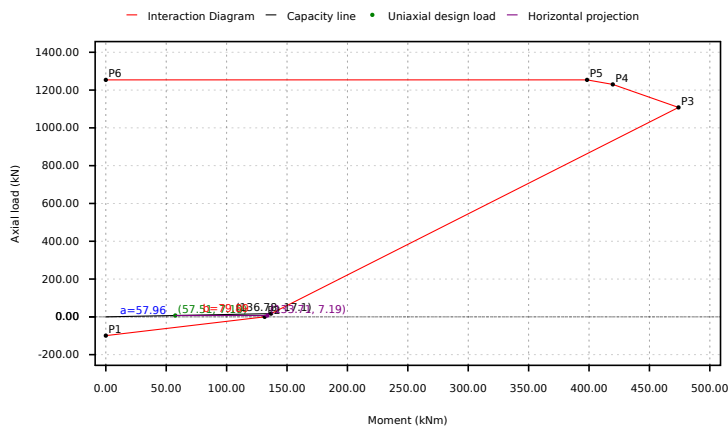

Segment	Signed Distance
P1 - P2	50.34
P2 - P3	72.8
P3 - P4	829.2
P4 - P5	1083
P5 - P6	1247
Status	PASS: Point lies inside the curve

Utilisation

$$Ratio = \frac{a}{a + b} = \frac{57.96}{57.96 + 79.89} = 0.42$$

UTILITY: 0.42

REFERENCES

CALCULATIONS

RESULTS

Results Summary

Result Name	Results
PILE DETAILS	
Length of the pile	9.50 ft
Dimension	36Ø in
Main bar reinforcement	#5-6pcs at 1.5 in min.
Shear reinforcement	#3 at 10 in max.
UTILISATIONS	
Required depth	0.89
End-bearing capacity	0.36
P _a	0.51

P_s	0.93
Axial compression strength	0.01
Shear strength	0.12
Uniaxial bending strength	0.42