

Your Project Calculations



Project Name: MTSOLAR_LOCDBC9949FH

S3D Model Link:

https://platform.skyciv.com/structural?preload_name=MTSOLAR_LOCDBC9949FH&preload_path=Shared%20Enterprise%20Folder/MT_Solar_Projects/4_2023

Public Model Link:

https://platform.skyciv.com/structural-viewer?project_id=5tnbUtWXqhGOxSgbECP6ri28JgDmuqJl2lvMpO25Wkqk7oPmxSrROFEXZse3Ygra

Array Specification

Product:	Beam
Unique ID:	2P-17-6TOP-SD-24-L-5Hx5W-5BLJ
Duty Classification:	SD
Module Width:	41.50 in
Module Length:	68.80in
Number of Rows:	5
Number of Columns:	5
Total Number of Modules:	25
Desired Tilt Angle:	60.7
Front Edge Clearance:	3
Total Array Height at Tilt:	18.17 ft
Total Frame Length:	28.50 ft
Frame Weight:	1424 lbs
Array Dimensions N/S:	17.50 ft
Array Dimensions E/W:	29.08 ft
Rail Length:	210.00 in
Rail Spacing:	2.87 ft
Rail Check:	Not Checked

Support Specifications

Pole Size:	6in Pipe Sch 80
Pole Length above Grade:	10.63 ft
Number of Poles:	2
Pole Spacing:	17 ft

Foundation Specifications

Foundation Type:	Square
Foundation Dimensions:	48 x 48 in
Foundation Depth (below grade):	Pile 1: 6.50 ft Pile 2: 6.50 ft
Foundation Volume:	7.704 y ³
Foundation Result:	PASSED

Site Info

Risk Category:	I
Exposure:	C
Soil Classification:	sand
Site Location:	310 Feldspar Way, Billings, MT 59106, USA
Wind Speed:	102 mph
Snow Load:	29 psf
Design Uplift Pressure:	0.019938 ksf
Design Downforce Pressure:	-0.019938 ksf
Design Snow Pressure:	0.001451 ksf

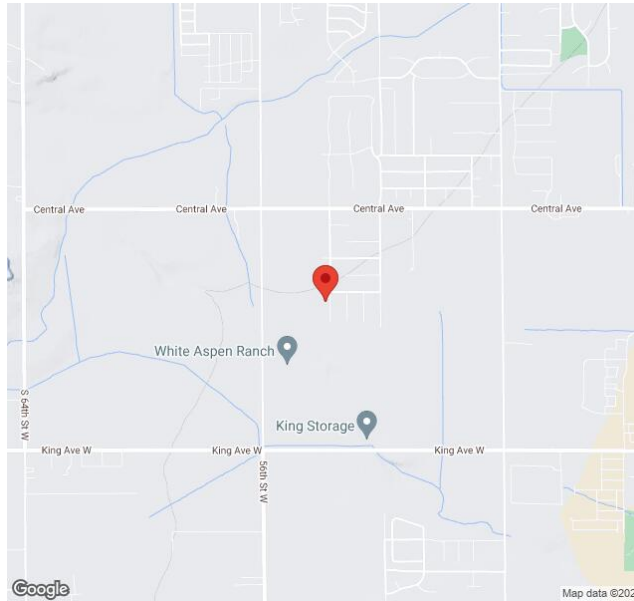

Design Disclaimer

This software should be used for preliminary designs and should not be used as a final design unless reviewed, verified and designed by a qualified structural engineer.

AutoDesigner Input

```
{
  "wind_speed_override": null,
  "snow_load_override": null,
  "direct_snow_load": false,
  "product_type": "Beam",
  "project_id": "MTSOLAR_L0CDB C9949FH",
  "site_address": "310 Feldspar Way, Billings, MT 59106, USA",
  "module_width": 41.5,
  "module_length": 68.8,
  "number_rows": 5,
  "number_columns": 5,
  "pole_mount_section": "4_40",
  "core_pipe_width": 65,
  "core_pipe_section": "2_40",
  "adjuster_section": "2_40",
  "core_beam_height": 65,
  "core_beam_section": "HSS3x2x1/8",
  "main_pipe_section": "2_12GA",
  "pole_spacing": 15,
  "tilt_angle": 60.7,
  "ground_clearance": 3,
  "risk_category": "I",
  "exposure_category": "C",
  "frame_duty_override": "auto",
  "pole_override": "auto",
  "soil_type": "sand",
  "foundation_type": "Square",
  "foundation_size": 48,
  "check_rails": false
}
```

Design Notes:

- AISC Deflection checks are set to L/1 due to structure design intent
- Foundation Design and Sizing is approximate only

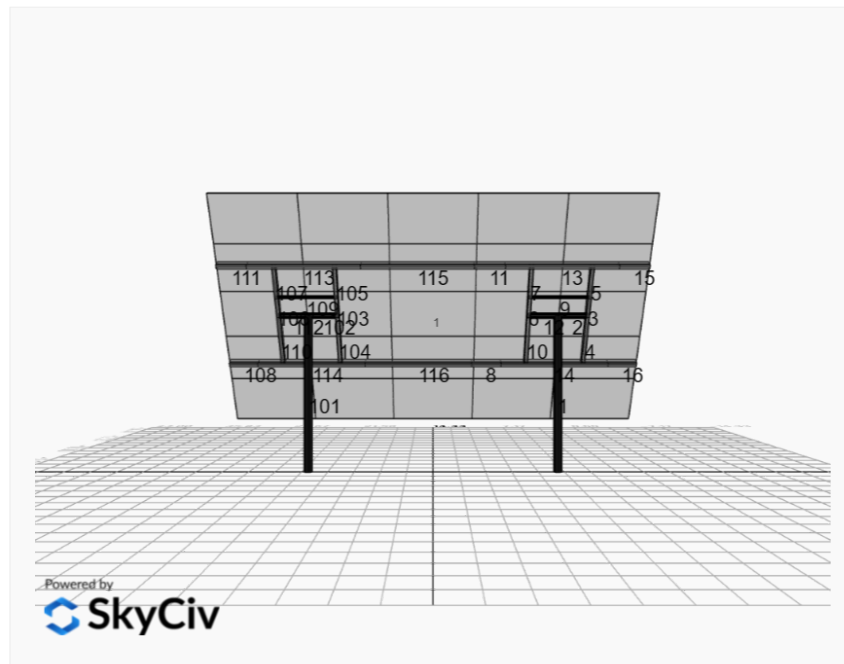

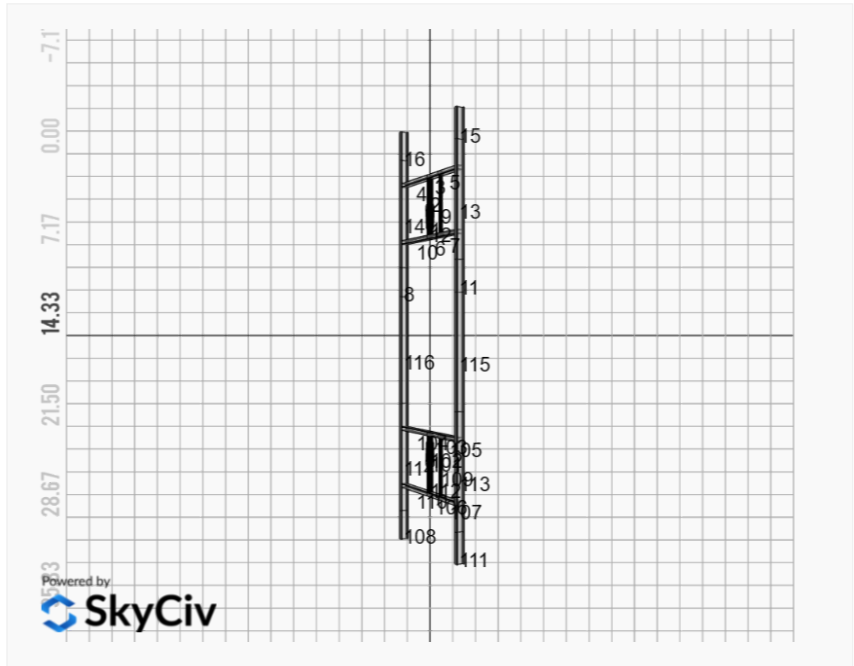
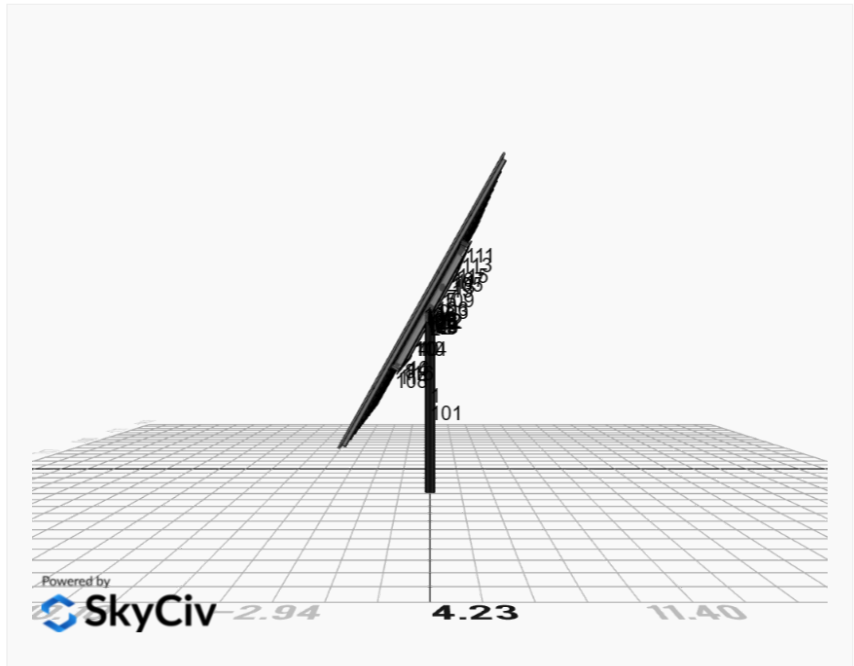

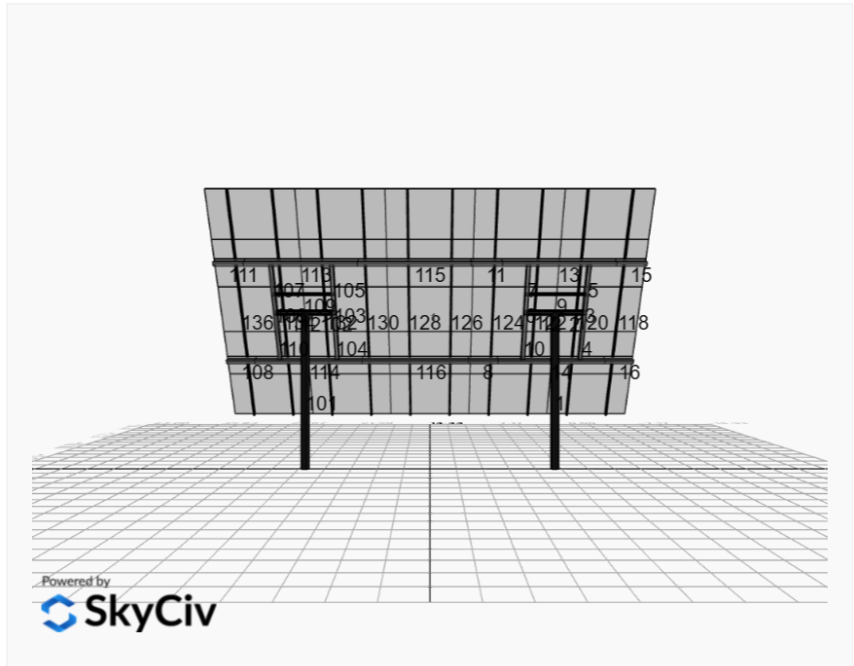
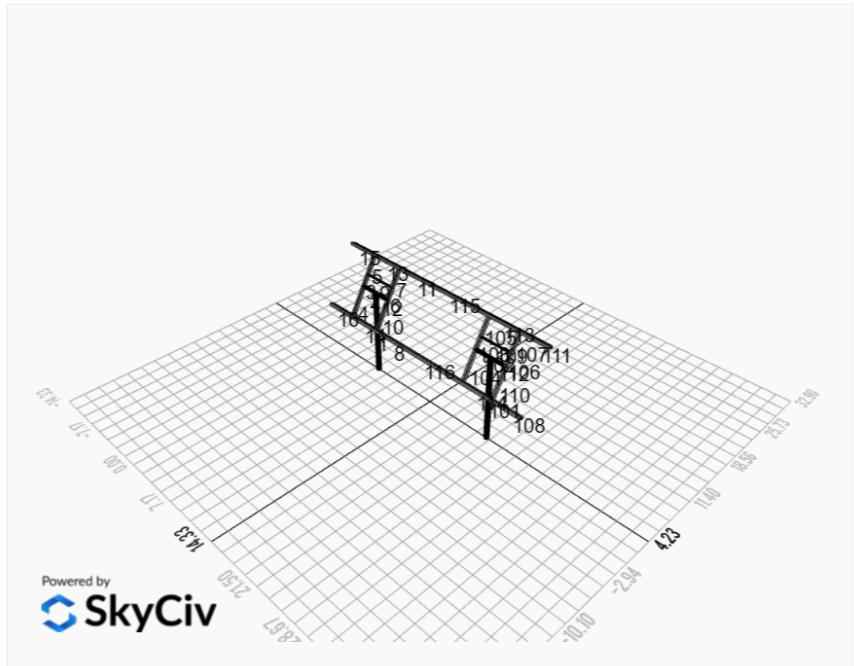

FEM Results (Envelope Worst Case for each member)

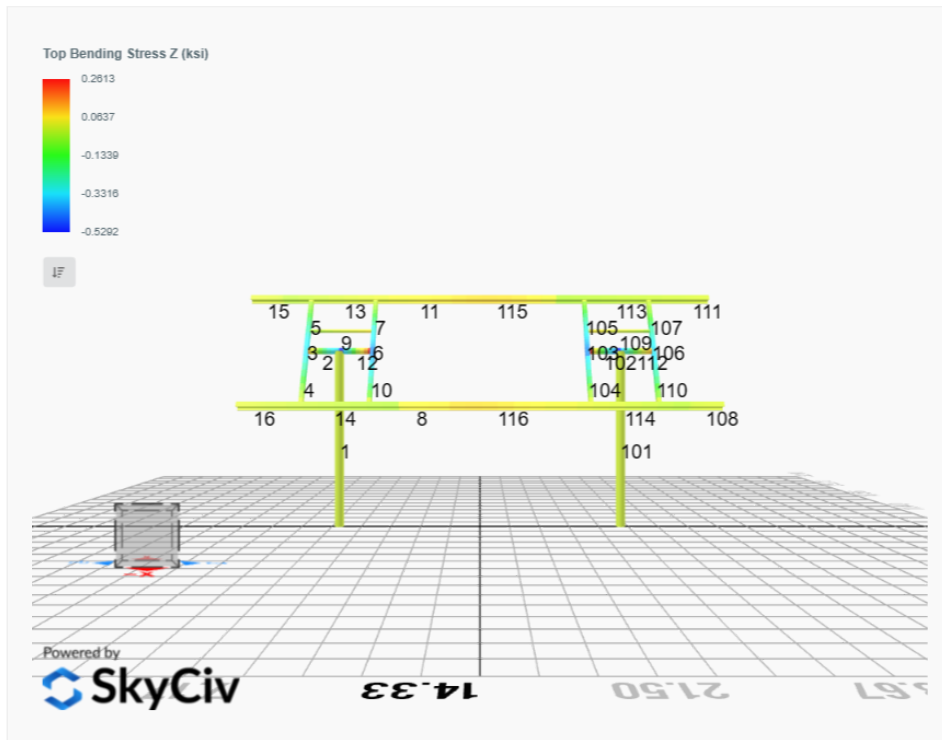
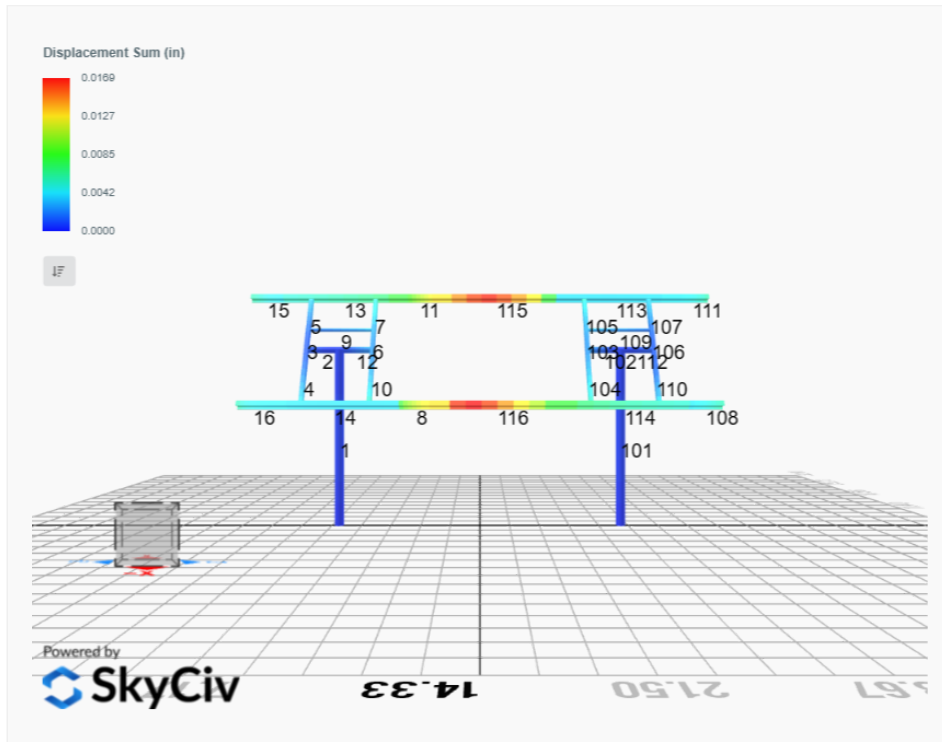

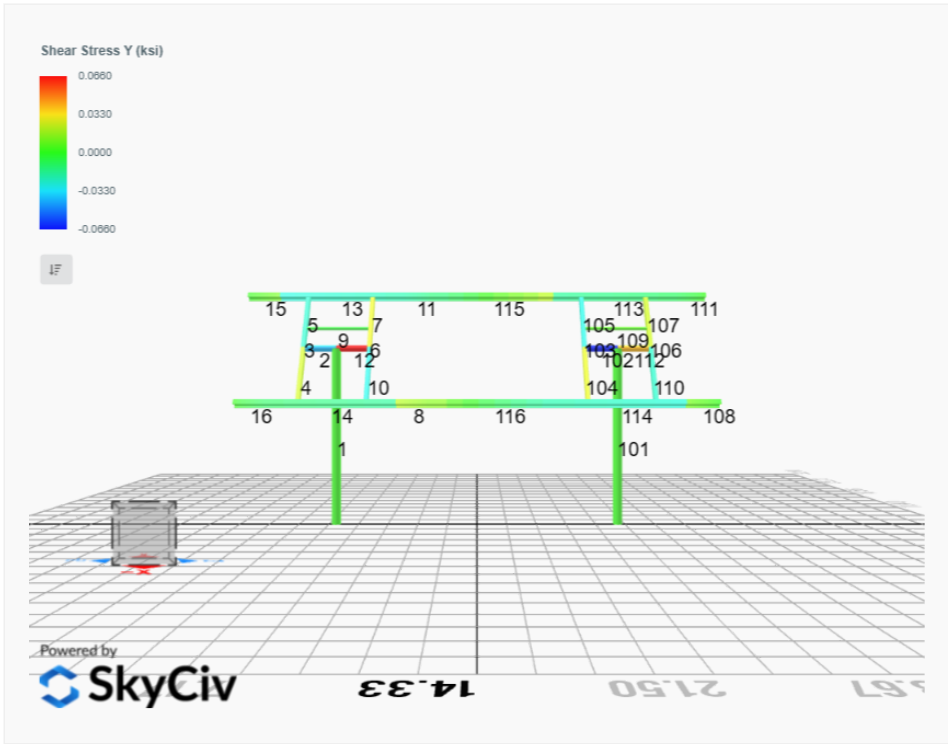
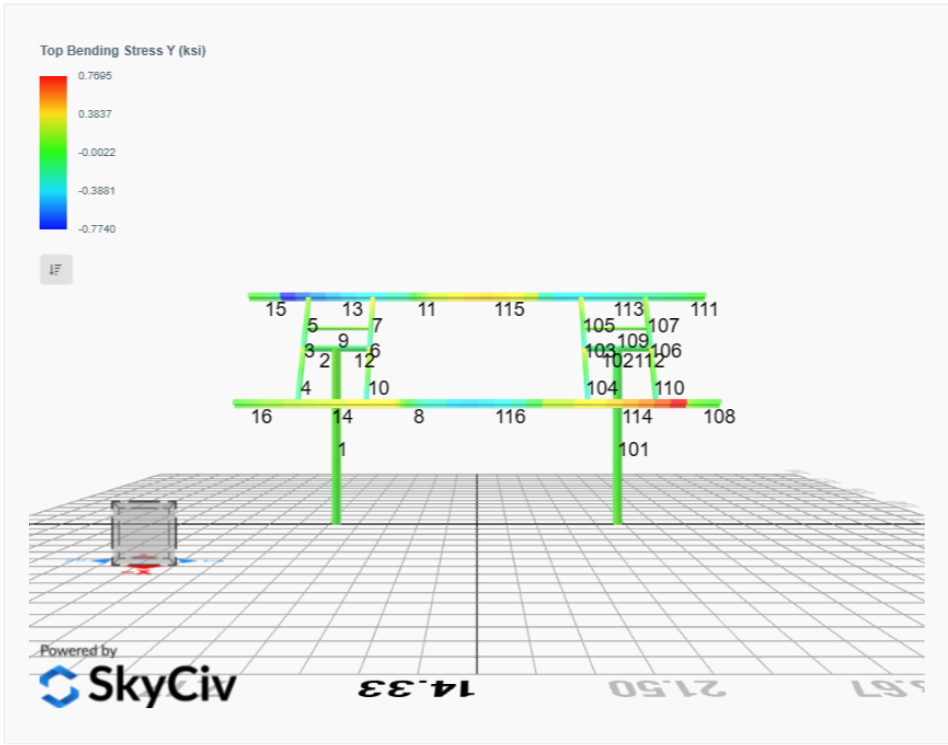

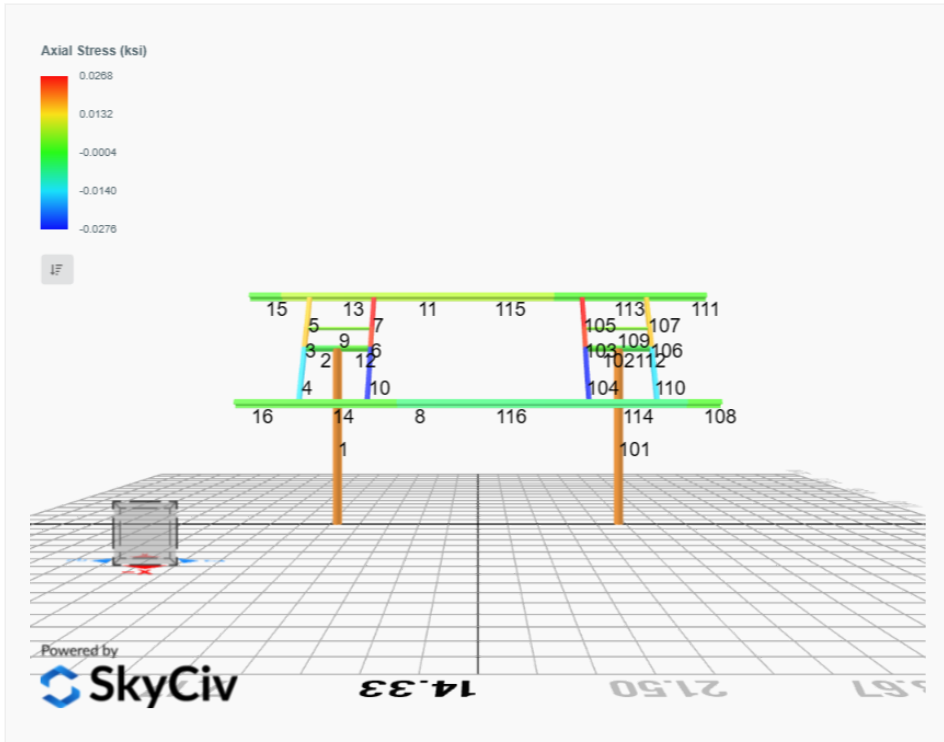

Reaction Forces for Foundation 1 (Node ID#1), (kip, kip-ft)

ASD Load Combination Results

Name	Fx	Fy	Fz	Mx	My	Mz
ULS: 1. D	0.0000	1.8800	0.0447	0.1467	-0.0497	0.0125
ULS: 2. D + L	0.0000	1.8800	0.0447	0.1467	-0.0497	0.0125
ULS: 3. D + (S or Lr or R)	0.0000	2.0572	0.0502	0.1649	-0.0559	0.0126
ULS: 3. D + (S or Lr or R)	0.0000	1.8800	0.0447	0.1467	-0.0497	0.0125
ULS: 4. D + 0.75L + 0.75(S or Lr or R)	0.0000	2.0129	0.0488	0.1603	-0.0543	0.0125
ULS: 4. D + 0.75L + 0.75(S or Lr or R)	0.0000	1.8800	0.0447	0.1467	-0.0497	0.0125
ULS: 5b. D + 0.7E	0.0000	1.8800	0.0447	0.1467	-0.0497	0.0125
ULS: 6b. D + 0.75L + 0.75(0.7)E + 0.75S	0.0000	2.0129	0.0488	0.1603	-0.0543	0.0125
ULS: 8. 0.6D + 0.7E	0.0000	1.1280	0.0268	0.0880	-0.0298	0.0075
ULS: 5a. D + 0.6W_Wind downforce Case A only	-2.6548	3.3698	0.1294	0.4077	-0.5537	28.5632
ULS: 5a. D + 0.6W_Wind downforce Case B only	0.0000	1.8800	0.0447	0.1467	-0.0497	0.0125
ULS: 5a. D + 0.6W_Wind uplift Case A only	2.6548	0.3902	-0.0400	-0.1135	0.4547	-27.8904
ULS: 5a. D + 0.6W_Wind uplift Case B only	0.0000	1.8800	0.0447	0.1467	-0.0497	0.0125
ULS: 6a. D + 0.75L + 0.75(0.6)W + 0.75(S or Lr or R)_Wind downforce Case A only	-1.9911	3.1302	0.1124	0.3561	-0.4324	21.4256
ULS: 6a. D + 0.75L + 0.75(0.6)W + 0.75(S or Lr or R)_Wind downforce Case B only	0.0000	2.0129	0.0488	0.1603	-0.0543	0.0125
ULS: 6a. D + 0.75L + 0.75(0.6)W + 0.75(S or Lr or R)_Wind uplift Case A only	1.9911	0.8955	-0.0147	-0.0348	0.3240	-20.9146
ULS: 6a. D + 0.75L + 0.75(0.6)W + 0.75(S or Lr or R)_Wind uplift Case B only	0.0000	2.0129	0.0488	0.1603	-0.0543	0.0125
ULS: 6a. D + 0.75L + 0.75(0.6)W + 0.75(S or Lr or R)_Wind downforce Case A only	-1.9911	2.9974	0.1083	0.3424	-0.4277	21.4256
ULS: 6a. D + 0.75L + 0.75(0.6)W + 0.75(S or Lr or R)_Wind downforce Case B only	0.0000	1.8800	0.0447	0.1467	-0.0497	0.0125
ULS: 6a. D + 0.75L + 0.75(0.6)W + 0.75(S or Lr or R)_Wind uplift Case A only	1.9911	0.7627	-0.0189	-0.0485	0.3286	-20.9147
ULS: 6a. D + 0.75L + 0.75(0.6)W + 0.75(S or Lr or R)_Wind uplift Case B only	0.0000	1.8800	0.0447	0.1467	-0.0497	0.0125
ULS: 7. 0.6D + 0.6W_Wind downforce Case A only	-2.6548	2.6178	0.1116	0.3490	-0.5339	28.5582
ULS: 7. 0.6D + 0.6W_Wind downforce Case B only	0.0000	1.1280	0.0268	0.0880	-0.0298	0.0075
ULS: 7. 0.6D + 0.6W_Wind uplift Case A only	2.6548	-0.3618	-0.0579	-0.1722	0.4746	-27.8954
ULS: 7. 0.6D + 0.6W_Wind uplift Case B only	0.0000	1.1280	0.0268	0.0880	-0.0298	0.0075

Worst Case Reactions LRFD

These calculations are taken directly from the FEA via SkyCiv and are used in the Concrete Checks of the Foundation Module.
 Note: Worst case values are assumed as downforce wind load cases.

Result	Value
Axial	4.8276
Shear X	-4.4247
Shear Z	0.1974
Moment X	0.6198
Moment Z	48.1655

Worst Case Reactions ASD

These results are taken from the worst case values in the above table and are used in the Soil Checks in the Foundation Module.
 Note: Worst case values are assumed as downforce wind load cases.

Result	Value
Axial	3.3698
Shear X	-2.6548
Shear Z	0.1294
Moment X	0.4077
Moment Z	28.5632

Reaction Forces for Foundation 2 (Node ID#101), (kip, kip-ft)

ASD Load Combination Results

Name	Fx	Fy	Fz	Mx	My	Mz
ULS: 1. D	-0.0000	1.8800	-0.0447	-0.1467	0.0497	0.0125
ULS: 2. D + L	-0.0000	1.8800	-0.0447	-0.1467	0.0497	0.0125
ULS: 3. D + (S or Lr or R)	-0.0000	2.0572	-0.0502	-0.1649	0.0559	0.0126
ULS: 3. D + (S or Lr or R)	-0.0000	1.8800	-0.0447	-0.1467	0.0497	0.0125
ULS: 4. D + 0.75L + 0.75(S or Lr or R)	-0.0000	2.0129	-0.0488	-0.1603	0.0543	0.0126
ULS: 4. D + 0.75L + 0.75(S or Lr or R)	-0.0000	1.8800	-0.0447	-0.1467	0.0497	0.0125
ULS: 5b. D + 0.7E	-0.0000	1.8800	-0.0447	-0.1467	0.0497	0.0125
ULS: 6b. D + 0.75L + 0.75(0.7)E + 0.75S	-0.0000	2.0129	-0.0488	-0.1603	0.0543	0.0126

Name	Fx	Fy	Fz	Mx	My	Mz
ULS: 8. 0.6D + 0.7E	-0.0000	1.1280	-0.0268	-0.0880	0.0298	0.0075
ULS: 5a. D + 0.6W_Wind downforce Case A only	-2.6548	3.3698	-0.1294	-0.4077	0.5538	28.5632
ULS: 5a. D + 0.6W_Wind downforce Case B only	-0.0000	1.8800	-0.0447	-0.1467	0.0497	0.0125
ULS: 5a. D + 0.6W_Wind uplift Case A only	2.6548	0.3902	0.0400	0.1135	-0.4547	-27.8904
ULS: 5a. D + 0.6W_Wind uplift Case B only	-0.0000	1.8800	-0.0447	-0.1467	0.0497	0.0125
ULS: 6a. D + 0.75L + 0.75(0.6)W + 0.75(S or Lr or R)_Wind downforce Case A only	-1.9911	3.1302	-0.1124	-0.3561	0.4324	21.4256
ULS: 6a. D + 0.75L + 0.75(0.6)W + 0.75(S or Lr or R)_Wind downforce Case B only	-0.0000	2.0129	-0.0488	-0.1603	0.0543	0.0126
ULS: 6a. D + 0.75L + 0.75(0.6)W + 0.75(S or Lr or R)_Wind uplift Case A only	1.9911	0.8955	0.0147	0.0348	-0.3240	-20.9146
ULS: 6a. D + 0.75L + 0.75(0.6)W + 0.75(S or Lr or R)_Wind uplift Case B only	-0.0000	2.0129	-0.0488	-0.1603	0.0543	0.0126
ULS: 6a. D + 0.75L + 0.75(0.6)W + 0.75(S or Lr or R)_Wind downforce Case A only	-1.9911	2.9974	-0.1083	-0.3424	0.4277	21.4256
ULS: 6a. D + 0.75L + 0.75(0.6)W + 0.75(S or Lr or R)_Wind downforce Case B only	-0.0000	1.8800	-0.0447	-0.1467	0.0497	0.0125
ULS: 6a. D + 0.75L + 0.75(0.6)W + 0.75(S or Lr or R)_Wind uplift Case A only	1.9911	0.7627	0.0189	0.0485	-0.3286	-20.9147
ULS: 6a. D + 0.75L + 0.75(0.6)W + 0.75(S or Lr or R)_Wind uplift Case B only	-0.0000	1.8800	-0.0447	-0.1467	0.0497	0.0125
ULS: 7. 0.6D + 0.6W_Wind downforce Case A only	-2.6548	2.6178	-0.1116	-0.3490	0.5339	28.5582
ULS: 7. 0.6D + 0.6W_Wind downforce Case B only	-0.0000	1.1280	-0.0268	-0.0880	0.0298	0.0075
ULS: 7. 0.6D + 0.6W_Wind uplift Case A only	2.6548	-0.3618	0.0579	0.1722	-0.4746	-27.8954
ULS: 7. 0.6D + 0.6W_Wind uplift Case B only	-0.0000	1.1280	-0.0268	-0.0880	0.0298	0.0075

Worst Case Reactions LRFD

These calculations are taken directly from the FEA via SkyCiv and are used in the Concrete Checks of the Foundation Module.
 Note: Worst case values are assumed as downforce wind load cases.

Result	Value
Axial	4.8276
Shear X	-4.4247
Shear Z	-0.1974
Moment X	-0.6199
Moment Z	48.1664

Worst Case Reactions ASD

These results are taken from the worst case values in the above table and are used in the Soil Checks in the Foundation Module.
 Note: Worst case values are assumed as downforce wind load cases.

Result	Value
Axial	3.3698
Shear X	-2.6548
Shear Z	-0.1294
Moment X	-0.4077
Moment Z	28.5632

Project Details

Design Code: AISC 360-16 LRFD
 Provision: LRFD
 Country: United States



User Name: sales@mtsolar.us
 Project Name: MTSOLAR_LOCDBC9949FH
 Unit System: imperial

Design Input Information

Design Factors			
Φ_t	Φ_c	Φ_b	Φ_v
0.9	0.9	0.9	0.9

Design Materials			
ID	E (ksi)	F _y (ksi)	F _u (ksi)
1	29000	50	65

Section Dimensions

ID	Name	d (in)	t _w (in)				
1	2in Pipe Sch 40	2.38	0.15				
4	4in Pipe Sch 40	4.50	0.24				
8	6in Pipe Sch 80	6.63	0.43				

ID	Name	d (in)	b (in)	t _w (in)	t _b (in)	r (in)	
15	HSS5x3x1/8	5.00	3.00	0.12	0.12	0.12	

ID	Name	d (in)	t _w (in)	b _t (in)	b _b (in)	t _t (in)	t _b (in)	r (in)
18	W6x9	5.90	0.17	3.94	3.94	0.21	0.21	0.25

Section Properties								
ID	Name	A (in ²)	J (in ⁴)	I _{yp} (in ⁴)	I _{zp} (in ⁴)	I _w (in ⁶)	S _{yp} (in ³)	S _{zp} (in ³)
1	2in Pipe Sch 40	1.07	1.33	0.67	0.67	0.00	0.76	0.76
4	4in Pipe Sch 40	3.17	14.47	7.23	7.23	0.00	4.31	4.31

14	120.60	118.62	23.36	6.45	30.09	45.74
15	120.60	96.18	23.36	6.45	30.09	45.74
16	120.60	96.18	23.36	6.45	30.09	45.74
17	120.60	110.58	23.36	6.45	30.09	45.74
18	120.60	118.62	23.36	6.45	30.09	45.74
19	120.60	110.58	23.36	6.45	30.09	45.74
20	120.60	118.62	23.36	6.45	30.09	45.74
21	120.60	110.58	23.36	6.45	30.09	45.74
22	120.60	118.62	23.36	6.45	30.09	45.74
23	120.60	110.58	23.36	6.45	30.09	45.74
24	120.60	118.62	23.36	6.45	30.09	45.74
101	378.22	127.46	62.23	62.23	113.47	113.47
102	142.83	141.72	16.17	16.17	42.85	42.85
103	79.65	74.02	10.99	4.60	29.14	16.61
104	79.65	72.01	10.99	4.60	29.14	16.61
105	79.65	73.44	10.99	4.60	29.14	16.61
106	79.65	74.02	10.99	4.60	29.14	16.61
107	79.65	73.44	10.99	4.60	29.14	16.61
108	120.60	96.18	23.36	6.45	30.09	45.74
109	48.35	43.11	2.85	2.85	14.51	14.51
110	79.65	72.01	10.99	4.60	29.14	16.61
111	120.60	96.18	23.36	6.45	30.09	45.74
112	142.83	141.72	16.17	16.17	42.85	42.85
113	120.60	118.62	23.36	6.45	30.09	45.74
114	120.60	118.62	23.36	6.45	30.09	45.74
115	120.60	89.27	19.09	6.45	30.09	45.74
116	120.60	89.27	19.09	6.45	30.09	45.74

Design Ratio

Member ID	P	M _z	M _y	V _y	V _z	(P,M _z ,M _y)	Worst LC	KL/r	δ	Status
1	0.038	0.774	0.024	0.039	0.002	0.803	#13	0.610	Not Required	Pass
2	0.001	0.173	0.227	0.044	0.048	0.401	#13	0.052	Not Required	Pass
3	0.005	0.467	0.052	0.046	0.007	0.510	#13	0.044	Not Required	Pass
4	0.005	0.465	0.083	0.047	0.012	0.550	#13	0.078	Not Required	Pass
5	0.005	0.290	0.057	0.047	0.007	0.296	#13	0.073	Not Required	Pass
6	0.007	0.565	0.105	0.057	0.018	0.666	#13	0.044	Not Required	Pass
7	0.008	0.350	0.127	0.056	0.018	0.377	#13	0.073	Not Required	Pass
8	0.002	0.111	0.040	0.033	0.006	0.148	#13	0.088	Not Required	Pass
9	0.000	0.038	0.062	0.003	0.002	0.084	#13	0.198	Not Required	Pass
10	0.008	0.563	0.132	0.056	0.018	0.621	#13	0.078	Not Required	Pass
11	0.001	0.110	0.041	0.033	0.006	0.145	#13	0.088	Not Required	Pass
12	0.001	0.265	0.283	0.061	0.057	0.548	#13	0.052	Not Required	Pass
13	0.001	0.046	0.127	0.045	0.009	0.162	#13	0.075	Not Required	Pass
14	0.000	0.063	0.067	0.026	0.005	0.123	#13	Not Required	Not Required	Pass
15	0.000	0.018	0.019	0.014	0.003	0.035	#13	Not Required	Not Required	Pass
16	0.000	0.018	0.019	0.014	0.003	0.035	#13	Not Required	Not Required	Pass
17	0.001	0.078	0.037	0.019	0.003	0.101	#13	0.115	Not Required	Pass
18	0.000	0.063	0.067	0.026	0.005	0.123	#13	Not Required	Not Required	Pass
19	0.002	0.080	0.056	0.019	0.004	0.111	#13	0.172	Not Required	Pass
20	0.002	0.045	0.125	0.045	0.009	0.159	#13	0.075	Not Required	Pass
21	0.001	0.078	0.037	0.019	0.003	0.101	#13	0.115	Not Required	Pass
22	0.001	0.047	0.127	0.045	0.009	0.163	#13	0.075	Not Required	Pass

23	0.002	0.080	0.056	0.019	0.004	0.111	#13	0.172	Not Required	Pass
24	0.000	0.063	0.067	0.026	0.005	0.123	#13	Not Required	Not Required	Pass
101	0.038	0.774	0.024	0.039	0.002	0.803	#13	0.610	Not Required	Pass
102	0.001	0.265	0.283	0.061	0.057	0.548	#13	0.052	Not Required	Pass
103	0.007	0.565	0.105	0.057	0.018	0.666	#13	0.044	Not Required	Pass
104	0.008	0.563	0.132	0.056	0.018	0.621	#13	0.078	Not Required	Pass
105	0.008	0.350	0.127	0.056	0.018	0.377	#13	0.073	Not Required	Pass
106	0.005	0.467	0.052	0.046	0.007	0.510	#13	0.044	Not Required	Pass
107	0.005	0.290	0.057	0.047	0.007	0.296	#13	0.073	Not Required	Pass
108	0.000	0.018	0.019	0.014	0.003	0.035	#13	Not Required	Not Required	Pass
109	0.000	0.038	0.062	0.003	0.002	0.083	#13	0.198	Not Required	Pass
110	0.005	0.465	0.083	0.047	0.012	0.550	#13	0.078	Not Required	Pass
111	0.000	0.018	0.019	0.014	0.003	0.035	#13	Not Required	Not Required	Pass
112	0.001	0.173	0.227	0.044	0.048	0.401	#13	0.052	Not Required	Pass
113	0.000	0.063	0.067	0.026	0.005	0.123	#13	Not Required	Not Required	Pass
114	0.002	0.045	0.125	0.045	0.009	0.159	#13	0.075	Not Required	Pass
115	0.002	0.173	0.075	0.033	0.006	0.239	#13	0.321	Not Required	Pass
116	0.002	0.174	0.075	0.033	0.006	0.244	#13	0.321	Not Required	Pass

Definitions

Φ_t	Safety factor for tensile
Φ_c	Safety factor for compression
Φ_b	Safety factor for flexure
Φ_v	Safety factor for shear
E	Modulus of elasticity
F_y	Specified minimum yield stress
F_u	Specified minimum tensile strength
A	Cross-sectional area
J	Torsional constant
I_{yp}	Moment of inertia about the Y axes
I_{zp}	Moment of inertia about the Z axes
I_w	Warping constant
S_{yp}	Plastic section modulus about the Y axis
S_{zp}	Plastic section modulus about the Z axis
KL	Effective length
C_b	Buckling modification factor (from all load combinations)
L_b	Length between braced points
LST	Limited slenderness for tension
LSC	Limited slenderness for compression
LD	Limited deflection
P_n	Nominal axial strength (tension/compression)
M_n	Nominal flexural strength (about Z/Y axis)
V_n	Nominal shear strength (along Z/Y axis)
P	Design ratio in case of axial force
M_z	Design ratio in case of bending about Z axis
M_y	Design ratio in case of bending about Y axis
V_y	Design ratio in case of shear along Y axis
V_z	Design ratio in case of shear along Z axis
(P, M_z , M_y)	Design ratio in case of axial force and bending action
KL/r	Design ratio in case of section slenderness
δ	Design ratio in case of member deflection
OK	Capacity is provided
NG	Capacity is not provided

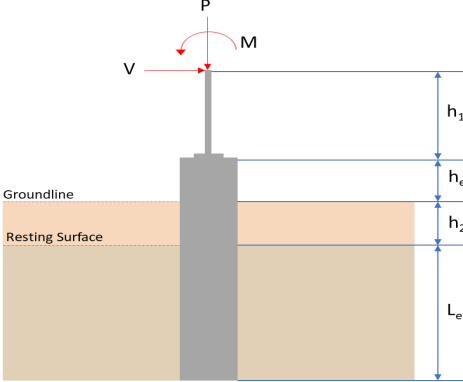
REFERENCES	CALCULATIONS	RESULTS																										
	<p>SkyCiv Foundation Design Pile Foundation</p> <p>Design Information : Design code : IBC 2021 (International Building Code) Unit System : Imperial</p>																											
	<p>Pile Input</p>  <p>Geometry Pile shape: rectangular $b = 48$ in - Pile width $D = 48$ in - Pile depth $L = 6.5$ ft - Total pile length $h_1 = 0$ ft - Lateral load height from the top of the pile, $h_2 = 0$ ft - Depth to resting surface $h_e = 0$ ft - Length of pile above the ground</p> <p>Tabulation of Soil Parameters</p> <table border="1" data-bbox="416 1102 1193 1191"> <thead> <tr> <th>Layer</th> <th>Label</th> <th>Allowable Bearing Pressure (q_a) (psf)</th> <th>Allowable Lateral Pressure (R) (psf/ft)</th> </tr> </thead> <tbody> <tr> <td>1</td> <td>Sand, silty sand, clayey sand, silty gravel & clayey gravel</td> <td>2000.000</td> <td>150.000</td> </tr> </tbody> </table> <p>Tabulation of Loads</p> <table border="1" data-bbox="676 1288 933 1458"> <thead> <tr> <th>Load Component</th> <th>ASD</th> <th>LRFD</th> </tr> </thead> <tbody> <tr> <td>P (kip)</td> <td>3.370</td> <td>4.828</td> </tr> <tr> <td>V_x (kip)</td> <td>-2.655</td> <td>-4.425</td> </tr> <tr> <td>V_z (kip)</td> <td>0.129</td> <td>0.197</td> </tr> <tr> <td>M_x (kipft)</td> <td>0.408</td> <td>0.620</td> </tr> <tr> <td>M_z (kipft)</td> <td>28.563</td> <td>48.166</td> </tr> </tbody> </table> <p>Material Properties $f'_{ck} = 3$ ksi - Concrete strength,</p>	Layer	Label	Allowable Bearing Pressure (q_a) (psf)	Allowable Lateral Pressure (R) (psf/ft)	1	Sand, silty sand, clayey sand, silty gravel & clayey gravel	2000.000	150.000	Load Component	ASD	LRFD	P (kip)	3.370	4.828	V_x (kip)	-2.655	-4.425	V_z (kip)	0.129	0.197	M_x (kipft)	0.408	0.620	M_z (kipft)	28.563	48.166	
Layer	Label	Allowable Bearing Pressure (q_a) (psf)	Allowable Lateral Pressure (R) (psf/ft)																									
1	Sand, silty sand, clayey sand, silty gravel & clayey gravel	2000.000	150.000																									
Load Component	ASD	LRFD																										
P (kip)	3.370	4.828																										
V_x (kip)	-2.655	-4.425																										
V_z (kip)	0.129	0.197																										
M_x (kipft)	0.408	0.620																										
M_z (kipft)	28.563	48.166																										
	<p>Required depth to resist lateral loads (ASD) H - Point of application of the lateral load</p> $H = h_1 + h_2 + h_e$ $H = (0 \text{ ft}) + (0 \text{ ft}) + (0 \text{ ft})$ $H = 0 \text{ ft}$ <p>Considering x-direction: H_o - Lateral force per length of pile,</p> $H_o = \frac{V_x}{1.57 D}$ $H_o = \frac{(-2.655 \text{ kip})}{1.57 \times (48 \text{ in})}$ $H_o = -0.42277 \text{ kip/ft}$ <p>M_o - Moment per length of pile,</p> $M_o = \frac{M_z + (V_x H)}{1.57 D}$																											

$$M_o = \frac{(28.563 \text{ kipft}) + ((-2.655 \text{ kip}) \times (0 \text{ ft}))}{1.57 \times (48 \text{ in})}$$

$$M_o = 4.5482 \text{ kipft/ft}$$

Required depth of embedment in earth:

$$L_x^3 - \left(14.14 \times \frac{H_o \times L_x}{R}\right) - \left(18.85 \times \frac{M_o}{R}\right) = 0$$

Solving the cubic equation:

$L_{e,x} = 5.9673 \text{ ft}$ - Required depth in x-direction,

Considering z-direction:

H_o - Lateral force per length of pile,

$$H_o = \frac{V_z}{1.57 b}$$

$$H_o = \frac{(0.129 \text{ kip})}{1.57 \times (48 \text{ in})}$$

$$H_o = 0.020541 \text{ kip/ft}$$

M_o - Moment per length of pile,

$$M_o = \frac{M_x + (V_z H)}{1.57 b}$$

$$M_o = \frac{(0.408 \text{ kipft}) + ((0.129 \text{ kip}) \times (0 \text{ ft}))}{1.57 \times (48 \text{ in})}$$

$$M_o = 0.064968 \text{ kipft/ft}$$

Required depth of embedment in earth:

$$L_z^3 - \left(14.14 \times \frac{H_o \times L_z}{R}\right) - \left(18.85 \times \frac{M_o}{R}\right) = 0$$

Solving the cubic equation:

$L_{e,z} = 1.9681 \text{ ft}$ - Required depth in z-direction,

Minimum embedded depth required:

$L_{e,req}$ - Depth of pile required,

$$L_{e,req} = \text{MAX}[L_{e,x}, L_{e,z}]$$

$$L_{e,req} = \text{MAX}[(5.9673 \text{ ft}), (1.9681 \text{ ft})]$$

$$L_{e,req} = 5.967 \text{ ft}$$

L_e - Actual embedded length of pile,

$$L_e = L - h_e - h_2$$

$$L_e = (6.5 \text{ ft}) - (0 \text{ ft}) - (0 \text{ ft})$$

$$L_e = 6.5 \text{ ft}$$

Ratio - Embedded depth

$$\text{Ratio} = \frac{L_{e,req}}{L_e}$$

$$\text{Ratio} = \frac{(5.967 \text{ ft})}{(6.5 \text{ ft})}$$

$$\text{Ratio} = 0.918$$

Status: **PASS**
Ratio: **0.920**

End-bearing Capacity (ASD)

A - Pile cross-section area

$$A = b D$$

$$A = (48 \text{ in}) \times (48 \text{ in})$$

$$A = 16 \text{ ft}^2$$

q - End-bearing pressure

$$q = \frac{P_o}{A}$$

$$q = \frac{(3.37 \text{ kip})}{(16 \text{ ft}^2)}$$

$$q = 0.21069 \text{ kip/ft}^2$$

$$q = 0.21062 \text{ kip/ft}^2$$

Check bearing capacity ratio:

Ratio - Capacity

$$\text{Ratio} = \frac{q}{q_a}$$

$$\text{Ratio} = \frac{(0.21062 \text{ kip/ft}^2)}{(2000 \text{ psf})}$$

$$\text{Ratio} = 0.10531$$

Status: **PASS**
Ratio: **0.110**

Czerniak

Lateral Soil Pressure (ASD):

L/D - Length to least lateral dimension ratio,

$$L/D = \frac{L}{D}$$

$$L/D = \frac{(6.5 \text{ ft})}{(48 \text{ in})}$$

$$L/D = 1.625$$

Since $L/D \leq 10$,

Pile is short.

Considering x-direction:

$H_o = -0.42277 \text{ kip/ft}$ - Lateral force per length of pile,

$M_o = 4.5482 \text{ kipft/ft}$ - Overturning moment per length of pile,

a - Distance from resting surface to pivot point,

$$a = \frac{(4 M_o L_e) + (3 H_o L_e^2)}{(6 M_o) + (4 H_o L_e)}$$

$$a = \frac{(4 \times (4.5482 \text{ kipft/ft}) \times (6.5 \text{ ft})) + (3 \times (-0.42277 \text{ kip/ft}) \times (6.5 \text{ ft})^2)}{(6 \times (4.5482 \text{ kipft/ft})) + (4 \times (-0.42277 \text{ kip/ft}) \times (6.5 \text{ ft}))}$$

$$a = 4.4889 \text{ ft}$$

p - Earth pressure against the pile at distance $a/2$ from resting surface,

$$p = \frac{0.75 [(4 M_o) + (3 H_o L_e)]^2}{L_e^2 [(3 M_o) + (2 H_o L_e)]}$$

$$p = \frac{0.75 [(4 \times (4.5482 \text{ kipft/ft})) + (3 \times (-0.42277 \text{ kip/ft}) \times (6.5 \text{ ft}))]^2}{(6.5 \text{ ft})^2 [(3 \times (4.5482 \text{ kipft/ft})) + (2 \times (-0.42277 \text{ kip/ft}) \times (6.5 \text{ ft}))]}$$

$$p = 0.21563 \text{ kip/ft}^2$$

s - Earth pressure against the pile at distance L_e ,

$$s = \frac{6 [(2 M_o) + (H_o L_e)]}{L_e^2}$$

$$s = \frac{6 [(2 \times (4.5482 \text{ kipft/ft})) + ((-0.42277 \text{ kip/ft}) \times (6.5 \text{ ft}))]}{(6.5 \text{ ft})^2}$$

$$s = 0.90156 \text{ kip/ft}^2$$

Check lateral soil pressure capacity:

p_a - Allowable lateral soil pressure at depth $a/2$,

$$p_a = R \frac{a}{2}$$

$$p_a = (150 \text{ psf/ft}) \times \frac{(4.4889 \text{ ft})}{2}$$

$$p_a = 0.33666 \text{ kip/ft}^2$$

Ratio - Lateral soil capacity

$$\text{Ratio} = \frac{p}{p_a}$$

$$\text{Ratio} = \frac{(0.21563 \text{ kip/ft}^2)}{(0.33666 \text{ kip/ft}^2)}$$

$$\text{Ratio} = 0.64048$$

p_a - Allowable lateral soil pressure at depth L_e ,

Status: **PASS**
Ratio: **0.640**

$$p_s = R L_e$$

$$p_s = (150 \text{ psf/ft}) \times (6.5 \text{ ft})$$

$$p_s = 0.975 \text{ kip/ft}^2$$

Ratio - Lateral soil capacity

$$\text{Ratio} = \frac{s}{p_s}$$

$$\text{Ratio} = \frac{(0.90156 \text{ kip/ft}^2)}{(0.975 \text{ kip/ft}^2)}$$

$$\text{Ratio} = 0.92468$$

Status: **PASS**
Ratio: **0.920**

Considering z-direction:

$H_o = 0.020541 \text{ kip/ft}$ - Lateral force per length of pile,

$M_o = 0.064968 \text{ kipft/ft}$ - Overturning moment per length of pile,

a - Distance from resting surface to pivot point,

$$a = \frac{(4 M_o L_e) + (3 H_o L_e^2)}{(6 M_o) + (4 H_o L_e)}$$

$$a = \frac{(4 \times (0.064968 \text{ kipft/ft}) \times (6.5 \text{ ft})) + (3 \times (0.020541 \text{ kip/ft}) \times (6.5 \text{ ft})^2)}{(6 \times (0.064968 \text{ kipft/ft})) + (4 \times (0.020541 \text{ kip/ft}) \times (6.5 \text{ ft}))}$$

$$a = 4.6465 \text{ ft}$$

p - Earth pressure against the pile at distance $a/2$ from resting surface,

$$p = \frac{0.75 [(4 M_o) + (3 H_o L_e)]^2}{L_e^2 [(3 M_o) + (2 H_o L_e)]}$$

$$p = \frac{0.75 [(4 \times (0.064968 \text{ kipft/ft})) + (3 \times (0.020541 \text{ kip/ft}) \times (6.5 \text{ ft}))]^2}{(6.5 \text{ ft})^2 [(3 \times (0.064968 \text{ kipft/ft})) + (2 \times (0.020541 \text{ kip/ft}) \times (6.5 \text{ ft}))]}$$

$$p = 0.016761 \text{ kip/ft}^2$$

s - Earth pressure against the pile at distance L_e ,

$$s = \frac{6 [(2 M_o) + (H_o L_e)]}{L_e^2}$$

$$s = \frac{6 [(2 \times (0.064968 \text{ kipft/ft})) + ((0.020541 \text{ kip/ft}) \times (6.5 \text{ ft}))]}{(6.5 \text{ ft})^2}$$

$$s = 0.037414 \text{ kip/ft}^2$$

Check lateral soil pressure capacity:

p_a - Allowable lateral soil pressure at depth $a/2$,

$$p_a = R \frac{a}{2}$$

$$p_a = (150 \text{ psf/ft}) \times \frac{(4.6465 \text{ ft})}{2}$$

$$p_a = 0.34848 \text{ kip/ft}^2$$

Ratio - Lateral soil capacity

$$\text{Ratio} = \frac{p}{p_a}$$

$$\text{Ratio} = \frac{(0.016761 \text{ kip/ft}^2)}{(0.34848 \text{ kip/ft}^2)}$$

$$\text{Ratio} = 0.048097$$

p_s - Allowable lateral soil pressure at depth L_e ,

$$p_s = R L_e$$

$$p_s = (150 \text{ psf/ft}) \times (6.5 \text{ ft})$$

$$p_s = 0.975 \text{ kip/ft}^2$$

Ratio - Lateral soil capacity

$$\text{Ratio} = \frac{s}{p_s}$$

Status: **PASS**
Ratio: **0.050**

$$Ratio = \frac{(0.037414 \text{ kip/ft}^2)}{(0.975 \text{ kip/ft}^2)}$$

$$Ratio = 0.038373$$

Status: **PASS**
Ratio: **0.040**

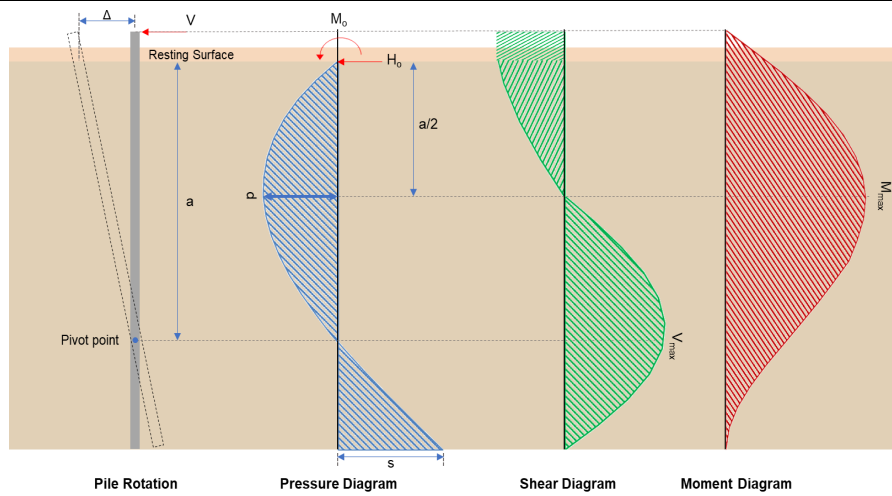

Shear force and Bending moment (x-direction, LRFD)

H_o - Lateral force per length of pile,

$$H_o = \frac{V_e}{1.57 D}$$

$$H_o = \frac{(-4.425 \text{ kip})}{1.57 \times (48 \text{ in})}$$

$$H_o = -0.70462 \text{ kip/ft}$$

M_o - Moment per length of pile,

$$M_o = \frac{M_z + (V_x H)}{1.57 D}$$

$$M_o = \frac{(48.166 \text{ kipft}) + ((-4.425 \text{ kip}) \times (0 \text{ ft}))}{1.57 \times (48 \text{ in})}$$

$$M_o = 7.6697 \text{ kipft/ft}$$

E - Distance from lateral load to resisting surface,

$$E = \frac{M_o}{H_o}$$

$$E = \frac{(7.6697 \text{ kipft/ft})}{(-0.70462 \text{ kip/ft})}$$

$$E = 10.885 \text{ ft}$$

a - Distance from resting surface to pivot point,

$$a = \frac{(4 M_o L_c) + (3 H_o L_c^2)}{(6 M_o) + (4 H_o L_c)}$$

$$a = \frac{(4 \times (7.6697 \text{ kipft/ft}) \times (6.5 \text{ ft})) + (3 \times (-0.70462 \text{ kip/ft}) \times (6.5 \text{ ft})^2)}{(6 \times (7.6697 \text{ kipft/ft})) + (4 \times (-0.70462 \text{ kip/ft}) \times (6.5 \text{ ft}))}$$

$$a = 4.4876 \text{ ft}$$

V_{max} - Max shear force located at depth a ,

$$V_{max} = (H_o D) \left[1 - \left[3 \left(\frac{4 E}{L_c} + 3 \right) \left(\frac{a}{L_c} \right)^2 \right] + \left[4 \left(\frac{3 E}{L_c} + 2 \right) \left(\frac{a}{L_c} \right)^3 \right] \right]$$

$$V_{max} = ((-0.70462 \text{ kip/ft}) \times (48 \text{ in})) \times \left[1 - \left[3 \times \left(\frac{4 \times (10.885 \text{ ft})}{(6.5 \text{ ft})} + 3 \right) \times \left(\frac{(4.4876 \text{ ft})}{(6.5 \text{ ft})} \right)^2 \right] + \left[4 \times \left(\frac{3 \times (10.885 \text{ ft})}{(6.5 \text{ ft})} + 2 \right) \times \left(\frac{(4.4876 \text{ ft})}{(6.5 \text{ ft})} \right)^3 \right] \right]$$

$$V_{max} = 10.211 \text{ kip}$$

M_{max} - Max bending moment located at depth $a/2$,

$$M_{max} = (H_o D L_e) \left[\left(\frac{E}{L_e} + \frac{a}{2 L_e} \right) - \left[\left(\frac{4E}{L_e} + 3 \right) \left(\frac{a}{2 L_e} \right)^3 + \left[\left(\frac{3E}{L_e} + 2 \right) \left(\frac{a}{2 L_e} \right)^4 \right] \right] \right]$$

$$M_{max} = ((-0.70462 \text{ kip/ft}) \times (48 \text{ in}) \times (6.5 \text{ ft})) \times \left[\left(\frac{(10.885 \text{ ft})}{(6.5 \text{ ft})} + \frac{(4.4876 \text{ ft})}{2 \times (6.5 \text{ ft})} \right) - \left[\left(\frac{4 \times (10.885 \text{ ft})}{(6.5 \text{ ft})} + 3 \right) \times \left(\frac{(4.4876 \text{ ft})}{2 \times (6.5 \text{ ft})} \right)^3 + \left[\left(\frac{3 \times (10.885 \text{ ft})}{(6.5 \text{ ft})} + 2 \right) \times \left(\frac{(4.4876 \text{ ft})}{2 \times (6.5 \text{ ft})} \right)^4 \right] \right] \right]$$

$$M_{max} = 31.522 \text{ kipft}$$

Shear force and Bending moment (z-direction, LRFD)

H_o - Lateral force per length of pile,

$$H_o = \frac{V_z}{1.57 b}$$

$$H_o = \frac{(0.197 \text{ kip})}{1.57 \times (48 \text{ in})}$$

$$H_o = 0.031369 \text{ kip/ft}$$

M_o - Moment per length of pile,

$$M_o = \frac{M_x + (V_z H)}{1.57 b}$$

$$M_o = \frac{(0.62 \text{ kipft}) + ((0.197 \text{ kip}) \times (0 \text{ ft}))}{1.57 \times (48 \text{ in})}$$

$$M_o = 0.098726 \text{ kipft/ft}$$

E - Distance from lateral load to resisting surface,

$$E = \frac{M_o}{H_o}$$

$$E = \frac{(0.098726 \text{ kipft/ft})}{(0.031369 \text{ kip/ft})}$$

$$E = 3.1472 \text{ ft}$$

a - Distance from resting surface to pivot point,

$$a = \frac{(4 M_o L_e) + (3 H_o L_e^2)}{(6 M_o) + (4 H_o L_e)}$$

$$a = \frac{(4 \times (0.098726 \text{ kipft/ft}) \times (6.5 \text{ ft})) + (3 \times (0.031369 \text{ kip/ft}) \times (6.5 \text{ ft})^2)}{(6 \times (0.098726 \text{ kipft/ft})) + (4 \times (0.031369 \text{ kip/ft}) \times (6.5 \text{ ft}))}$$

$$a = 4.6471 \text{ ft}$$

V_{max} - Max shear force located at depth a ,

$$V_{max} = (H_o b) \left[1 - \left[3 \left(\frac{4E}{L_e} + 3 \right) \left(\frac{a}{L_e} \right)^2 + 4 \left(\frac{3E}{L_e} + 2 \right) \left(\frac{a}{L_e} \right)^3 \right] \right]$$

$$V_{max} = ((0.031369 \text{ kip/ft}) \times (48 \text{ in})) \times \left[1 - \left[3 \times \left(\frac{4 \times (3.1472 \text{ ft})}{(6.5 \text{ ft})} + 3 \right) \times \left(\frac{(4.6471 \text{ ft})}{(6.5 \text{ ft})} \right)^2 + 4 \times \left(\frac{3 \times (3.1472 \text{ ft})}{(6.5 \text{ ft})} + 2 \right) \times \left(\frac{(4.6471 \text{ ft})}{(6.5 \text{ ft})} \right)^3 \right] \right]$$

$$V_{max} = 0.19115 \text{ kip}$$

M_{max} - Max bending moment located at depth $a/2$,

$$M_{max} = (H_o b L_e) \left[\left(\frac{E}{L_e} + \frac{a}{2 L_e} \right) - \left[\left(\frac{4E}{L_e} + 3 \right) \left(\frac{a}{2 L_e} \right)^3 + \left[\left(\frac{3E}{L_e} + 2 \right) \left(\frac{a}{2 L_e} \right)^4 \right] \right] \right]$$

$$M_{max} = ((0.031369 \text{ kip/ft}) \times (48 \text{ in}) \times (6.5 \text{ ft})) \times \left[\left(\frac{(3.1472 \text{ ft})}{(6.5 \text{ ft})} + \frac{(4.6471 \text{ ft})}{2 \times (6.5 \text{ ft})} \right) - \left[\left(\frac{4 \times (3.1472 \text{ ft})}{(6.5 \text{ ft})} + 3 \right) \times \left(\frac{(4.6471 \text{ ft})}{2 \times (6.5 \text{ ft})} \right)^3 + \left[\left(\frac{3 \times (3.1472 \text{ ft})}{(6.5 \text{ ft})} + 2 \right) \times \left(\frac{(4.6471 \text{ ft})}{2 \times (6.5 \text{ ft})} \right)^4 \right] \right] \right]$$

$$M_{max} = 0.54852 \text{ kipft}$$

Minimum Reinforcement Check (LRFD)

Parameters:

$f'_{ck} = 3 \text{ ksi}$ - Concrete strength,
 $f_{yk} = 60 \text{ ksi}$ - Longitudinal reinforcement strength,
 $\phi = 0.65$ - Reduction factor for axial strength,
 $\alpha = 0.8$ - Alpha factor for axial strength,
 $A_g = 2304 \text{ in}^2$ - Gross area of concrete,

Table 22.4.2.1

Longitudinal reinforcement:

Required reinforcement due to axial load, $A_{st,required}$

22.4.2.2, 10.6.1.1

$A_{st,required}$

$$A_{st,required} = \text{Min} \left[\frac{\frac{P}{\phi \alpha} - (0.85 f'_{ck} A_g)}{f_{yk} - (0.85 f'_{ck})}, (0.08 A_g) \right]$$

$$A_{st,required} = \text{Min} \left[\frac{\frac{(4.828 \text{ kip})}{(0.65) \times (0.8)} - (0.85 \times (3 \text{ ksi}) \times (2304 \text{ in}^2))}{(60 \text{ ksi}) - (0.85 \times (3 \text{ ksi}))}, (0.08 \times (2304 \text{ in}^2)) \right]$$

$$A_{st,required} = -102.1 \text{ in}^2$$

A_{min} - Governing minimum reinforcement area,

$$A_{min} = \text{Max} [A_{st,required}, (0.0018 A_g)]$$

$$A_{min} = \text{Max} [(-102.1 \text{ in}^2), (0.0018 \times (2304 \text{ in}^2))]$$

$$A_{min} = 4.1472 \text{ in}^2$$

n_{rebar} - Required number of reinforcement,

$$n_{rebar} = \frac{A_{min}}{A_{rebar}}$$

$$n_{rebar} = \frac{(4.1472 \text{ in}^2)}{(0.3068 \text{ in}^2)}$$

$$n_{rebar} = 14$$

A_{st} - Actual total reinforcement area,

$$A_{st} = n_{rebar} \frac{\pi d_{bar}^2}{4}$$

$$A_{st} = (14) \times \frac{\pi \times (0.625 \text{ in})^2}{4}$$

$$A_{st} = 4.2951 \text{ in}^2$$

Ratio - Capacity

$$\text{Ratio} = \frac{A_{min}}{A_{st}}$$

$$\text{Ratio} = \frac{(4.1472 \text{ in}^2)}{(4.2951 \text{ in}^2)}$$

$$\text{Ratio} = 0.96556$$

Status: **PASS**
Ratio: **0.970**

25.2.3

s_{rebar} - Minimum spacing of reinforcement,

$$s_{rebar} = \text{Max} [1.5, (1.5 d_{bar})]$$

$$s_{rebar} = \text{Max} [1.5, (1.5 \times (0.625 \text{ in}))]$$

$$s_{rebar} = 1.5 \text{ in}$$

Ties:

25.7.2.2

Since longitudinal reinforcement is \leq No. 10: Use #3(0.375 in)

25.7.2.1

s_{ties} - Maximum spacing of ties,

$$s_{ties} = \text{Min} [(16 d_{bar}), (48 d_{ties}), \text{Min} (D, b)]$$

$$s_{ties} = \text{Min} [(16 \times (0.625 \text{ in})), (48 \times (0.375 \text{ in})), \text{Min} ((48 \text{ in}), (48 \text{ in}))]$$

$$s_{ties} = 10 \text{ in}$$

Summary:

Main reinforcement: **14 - #5 (0.625 in)**

Ties: #3(0.375 in) - 10 in

Axial Compression Strength (ACI 318-19, LRFD)

22.4.2.2

ϕP_N - Allowable axial compressive strength

$$\phi P_N = \phi 0.80 [(0.85 f'_{ck} [A_g - A_{st}] + (f_{yk} A_{st})]$$

$$\phi P_N = (0.65) \times 0.80 \times [(0.85 \times (3 \text{ ksi}) \times [(2304 \text{ in}^2) - (4.2951 \text{ in}^2)]) + ((60 \text{ ksi}) \times (4.2951 \text{ in}^2))]$$

$$\phi P_N = 3183.4 \text{ kip}$$

Ratio - Capacity

$$\text{Ratio} = \frac{P}{\phi P_N}$$

$$\text{Ratio} = \frac{(4.828 \text{ kip})}{(3183.4 \text{ kip})}$$

$$\text{Ratio} = 0.0015166$$

Status: **PASS**
Ratio: **0.000**

Shear Strength (ACI 318-19, LRFD)

Parameters:

22.5.2.2

$b_w = 48 \text{ in}$ - Effective width,
 d - Effective depth

$$d = 0.80 D$$

$$d = 0.80 \times (48 \text{ in})$$

$$d = 38.4 \text{ in}$$

22.5.5.1.3

λ_s - size effect modification factor

$$\lambda_s = \text{MIN} \left[\sqrt{\frac{2}{1 + \frac{d}{10}}}, 1 \right]$$

$$\lambda_s = \text{MIN} \left[\sqrt{\frac{2}{1 + \frac{(38.4 \text{ in})}{10}}}, 1 \right]$$

$$\lambda_s = 0.64282$$

22.5.5.1.1

The following variables were converted to be consistent with empirical formula $f'_{ck} = 3 \text{ ksi} \rightarrow 3000 \text{ psi}$,
 $V_{c,max}$ - Max shear strength of concrete

$$V_{c,max} = 5 \lambda_s \sqrt{f'_{ck}} b_w d$$

$$V_{c,max} = 5 \times (0.64282) \times \sqrt{(3000 \text{ psi})} \times (48 \text{ in}) \times (38.4 \text{ in})$$

$$V_{c,max} = 324.49 \text{ kip}$$

22.5.5.1.1(a)

The following variables were converted to be consistent with empirical formula $f'_{ck} = 3 \text{ ksi} \rightarrow 3000 \text{ psi}$, $P = 4.828 \text{ kip} \rightarrow 4828 \text{ lbf}$,
 $V_{c,a}$ - Shear strength of concrete (a)

$$V_{c,a} = \left[2 \lambda_s \sqrt{f'_{ck}} + \frac{P}{6 A_g} \right] b_w d$$

$$V_{c,a} = \left[2 \times (0.64282) \times \sqrt{(3000 \text{ psi})} + \frac{(4828 \text{ lbf})}{6 \times (2304 \text{ in}^2)} \right] \times (48 \text{ in}) \times (38.4 \text{ in})$$

$$V_{c,a} = 130.44 \text{ kip}$$

22.5.5.1.2

The following variables were converted to be consistent with empirical formula $f'_{ck} = 3 \text{ ksi} \rightarrow 3000 \text{ psi}$,
 $V_{c,b}$ - Shear strength of concrete (b)

$$V_{c,b} = \left[2 \lambda_s \sqrt{f'_{ck}} + (0.05 f'_{ck}) \right] b_w d$$

$$V_{c,b} = \left[2 \times (0.64282) \times \sqrt{(3000 \text{ psi})} + (0.05 \times (3000 \text{ psi})) \right] \times (48 \text{ in}) \times (38.4 \text{ in})$$

$$V_{c,b} = 406.27 \text{ kip}$$

V_c - Governing shear strength of concrete

$$V_c = \text{Min}[V_{c,max}, V_{c,a}, V_{c,b}]$$

$$V_c = \text{Min}[(324.49 \text{ kip}), (130.44 \text{ kip}), (406.27 \text{ kip})]$$

$$V_c = 130.44 \text{ kip}$$

<p>22.5.1.2</p>	<p>The following variables were converted to be consistent with empirical formula $f'_{ck} = 3 \text{ ksi} \rightarrow 3000 \text{ psi}$, $V_{s,a}$ - Shear strength of steel (a)</p> $V_{s,a} = 8 \sqrt{f'_{ck}} b_w d$ $V_{s,a} = 8 \times \sqrt{(3000 \text{ psi})} \times (48 \text{ in}) \times (38.4 \text{ in})$ $V_{s,a} = 807.65 \text{ kip}$ <p>A_v - Ties rebar area,</p> $A_v = \frac{\pi d_{ties}^2}{4}$ $A_v = \frac{\pi \times (0.375 \text{ in})^2}{4}$ $A_v = 0.11045 \text{ in}^2$ <p>22.5.8.5.3 $V_{s,b}$ - Shear strength of steel (b)</p> $V_{s,b} = \frac{2 A_v f_{yt} d}{s_{ties}}$ $V_{s,b} = \frac{2 \times (0.11045 \text{ in}^2) \times (60 \text{ ksi}) \times (38.4 \text{ in})}{(10 \text{ in})}$ $V_{s,b} = 50.894 \text{ kip}$ <p>V_s - Governing shear strength of steel</p> $V_s = \text{MIN}[V_{s,a}, V_{s,b}]$ $V_s = \text{MIN}[(807.65 \text{ kip}), (50.894 \text{ kip})]$ $V_s = 50.894 \text{ kip}$ <p>22.5.1.1 ϕV_n - Allowable shear strength</p> $\phi V_n = \phi (V_c + V_s)$ $\phi V_n = (0.65) \times ((130.44 \text{ kip}) + (50.894 \text{ kip}))$ $\phi V_n = 117.87 \text{ kip}$ <p>Considering x-direction:</p> <p>$V_{max} = 10.211 \text{ kip}$ - Maximum shear force in the x-direction, Ratio - Capacity</p> $\text{Ratio} = \frac{V_{max}}{\phi V_n}$ $\text{Ratio} = \frac{(10.211 \text{ kip})}{(117.87 \text{ kip})}$ $\text{Ratio} = 0.086629$ <p>Considering z-direction:</p> <p>$V_{max} = 0.19115 \text{ kip}$ - Maximum shear force in the z-direction, Ratio - Capacity</p> $\text{Ratio} = \frac{V_{max}}{\phi V_n}$ $\text{Ratio} = \frac{(0.19115 \text{ kip})}{(117.87 \text{ kip})}$ $\text{Ratio} = 0.0016217$	<p>Status: PASS Ratio: 0.090</p> <p>Status: PASS Ratio: 0.000</p>
	<p>Flexural Strength (ACI 318-19, LRFD)</p> <p>S_m - Section modulus</p> $S_m = \frac{b D^2}{6}$ $S_m = \frac{(48 \text{ in}) \times (48 \text{ in})^2}{6}$ $S_m = 18432 \text{ in}^3$	

<p>14.5.2.1b</p>	<p>$\lambda = 1$ - Concrete modification factor (Normal concrete), Allowable flexural strength: M_n shall be the lesser of: $\phi M_{n,1}$</p> $\phi M_{n,1} = \phi \times 5 \times \lambda \times \sqrt{f'_c} \times S_m$ $\phi M_{n,1} = 0.65 \times 5 \times 1 \times \sqrt{3\text{ksi}} \times 18432.001\text{in}^3$ $\phi M_{n,1} = 273.423\text{kipft}$ <p>$\phi M_{n,2}$</p> $\phi M_{n,2} = \phi \times 0.85 \times f'_c \times S_m$ $\phi M_{n,2} = (0.65) \times 0.85 \times (3\text{ksi}) \times (18432\text{in}^3)$ $\phi M_{n,2} = 2545.9\text{kipft}$ <p>Therefore, ϕM_n - Allowable flexural strength,</p> $\phi M_n = \text{MIN}[\phi M_{n,1}, \phi M_{n,2}]$ $\phi M_n = \text{MIN}[(273.42\text{kipft}), (2545.9\text{kipft})]$ $\phi M_n = 273.42\text{kipft}$ <p>Considering x-direction: $M_{max} = 31.522\text{kipft}$ - Maximum moment in the x-direction, Ratio - Capacity</p> $\text{Ratio} = \frac{M_{max}}{\phi M_n}$ $\text{Ratio} = \frac{(31.522\text{kipft})}{(273.42\text{kipft})}$ $\text{Ratio} = 0.11529$	<p>Status: PASS Ratio: 0.120</p>
	<p>Considering z-direction: $M_{max} = 0.54852\text{kipft}$ - Maximum moment in the z-direction, Ratio - Capacity</p> $\text{Ratio} = \frac{M_{max}}{\phi M_n}$ $\text{Ratio} = \frac{(0.54852\text{kipft})}{(273.42\text{kipft})}$ $\text{Ratio} = 0.0020061$	<p>Status: PASS Ratio: 0.000</p>

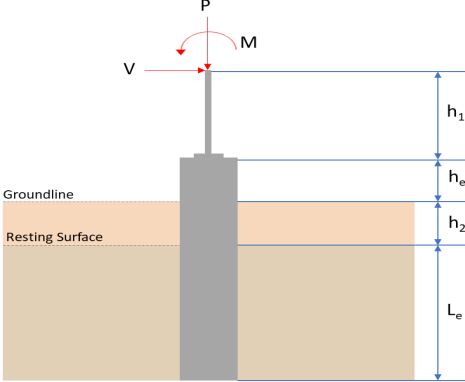
REFERENCES	CALCULATIONS	RESULTS																										
	<p>SkyCiv Foundation Design Pile Foundation</p> <p>Design Information : Design code : IBC 2021 (International Building Code) Unit System : Imperial</p>																											
	<p>Pile Input</p>  <p>Geometry Pile shape: rectangular $b = 48$ in - Pile width $D = 48$ in - Pile depth $L = 6.5$ ft - Total pile length $h_1 = 0$ ft - Lateral load height from the top of the pile, $h_2 = 0$ ft - Depth to resting surface $h_e = 0$ ft - Length of pile above the ground</p> <p>Tabulation of Soil Parameters</p> <table border="1" data-bbox="416 1102 1193 1191"> <thead> <tr> <th>Layer</th> <th>Label</th> <th>Allowable Bearing Pressure (q_a) (psf)</th> <th>Allowable Lateral Pressure (R) (psf/ft)</th> </tr> </thead> <tbody> <tr> <td>1</td> <td>Sand, silty sand, clayey sand, silty gravel & clayey gravel</td> <td>2000.000</td> <td>150.000</td> </tr> </tbody> </table> <p>Tabulation of Loads</p> <table border="1" data-bbox="676 1288 935 1458"> <thead> <tr> <th>Load Component</th> <th>ASD</th> <th>LRFD</th> </tr> </thead> <tbody> <tr> <td>P (kip)</td> <td>3.370</td> <td>4.828</td> </tr> <tr> <td>V_x (kip)</td> <td>-2.655</td> <td>-4.425</td> </tr> <tr> <td>V_z (kip)</td> <td>-0.129</td> <td>-0.197</td> </tr> <tr> <td>M_x (kipft)</td> <td>-0.408</td> <td>-0.620</td> </tr> <tr> <td>M_z (kipft)</td> <td>28.563</td> <td>48.166</td> </tr> </tbody> </table> <p>Material Properties $f'_{ck} = 3$ ksi - Concrete strength,</p>	Layer	Label	Allowable Bearing Pressure (q_a) (psf)	Allowable Lateral Pressure (R) (psf/ft)	1	Sand, silty sand, clayey sand, silty gravel & clayey gravel	2000.000	150.000	Load Component	ASD	LRFD	P (kip)	3.370	4.828	V_x (kip)	-2.655	-4.425	V_z (kip)	-0.129	-0.197	M_x (kipft)	-0.408	-0.620	M_z (kipft)	28.563	48.166	
Layer	Label	Allowable Bearing Pressure (q_a) (psf)	Allowable Lateral Pressure (R) (psf/ft)																									
1	Sand, silty sand, clayey sand, silty gravel & clayey gravel	2000.000	150.000																									
Load Component	ASD	LRFD																										
P (kip)	3.370	4.828																										
V_x (kip)	-2.655	-4.425																										
V_z (kip)	-0.129	-0.197																										
M_x (kipft)	-0.408	-0.620																										
M_z (kipft)	28.563	48.166																										
	<p>Required depth to resist lateral loads (ASD) H - Point of application of the lateral load</p> $H = h_1 + h_2 + h_e$ $H = (0 \text{ ft}) + (0 \text{ ft}) + (0 \text{ ft})$ $H = 0 \text{ ft}$ <p>Considering x-direction: H_o - Lateral force per length of pile,</p> $H_o = \frac{V_x}{1.57 D}$ $H_o = \frac{(-2.655 \text{ kip})}{1.57 \times (48 \text{ in})}$ $H_o = -0.42277 \text{ kip/ft}$ <p>M_o - Moment per length of pile,</p> $M_o = \frac{M_z + (V_x H)}{1.57 D}$																											

$$M_o = \frac{(28.563 \text{ kipft}) + ((-2.655 \text{ kip}) \times (0 \text{ ft}))}{1.57 \times (48 \text{ in})}$$

$$M_o = 4.5482 \text{ kipft/ft}$$

Required depth of embedment in earth:

$$L_x^3 - \left(14.14 \times \frac{H_o \times L_x}{R}\right) - \left(18.85 \times \frac{M_o}{R}\right) = 0$$

Solving the cubic equation:

$L_{e,x} = 5.9673 \text{ ft}$ - Required depth in x-direction,

Considering z-direction:

H_o - Lateral force per length of pile,

$$H_o = \frac{V_z}{1.57 b}$$

$$H_o = \frac{(-0.129 \text{ kip})}{1.57 \times (48 \text{ in})}$$

$$H_o = -0.020541 \text{ kip/ft}$$

M_o - Moment per length of pile,

$$M_o = \frac{M_x + (V_z H)}{1.57 b}$$

$$M_o = \frac{(0.408 \text{ kipft}) + ((-0.129 \text{ kip}) \times (0 \text{ ft}))}{1.57 \times (48 \text{ in})}$$

$$M_o = 0.064968 \text{ kipft/ft}$$

Required depth of embedment in earth:

$$L_z^3 - \left(14.14 \times \frac{H_o \times L_z}{R}\right) - \left(18.85 \times \frac{M_o}{R}\right) = 0$$

Solving the cubic equation:

$L_{e,z} = 1.4967 \text{ ft}$ - Required depth in z-direction,

Minimum embedded depth required:

$L_{e,req}$ - Depth of pile required,

$$L_{e,req} = \text{MAX}[L_{e,x}, L_{e,z}]$$

$$L_{e,req} = \text{MAX}[(5.9673 \text{ ft}), (1.4967 \text{ ft})]$$

$$L_{e,req} = 5.967 \text{ ft}$$

L_e - Actual embedded length of pile,

$$L_e = L - h_c - h_2$$

$$L_e = (6.5 \text{ ft}) - (0 \text{ ft}) - (0 \text{ ft})$$

$$L_e = 6.5 \text{ ft}$$

Ratio - Embedded depth

$$\text{Ratio} = \frac{L_{e,req}}{L_e}$$

$$\text{Ratio} = \frac{(5.967 \text{ ft})}{(6.5 \text{ ft})}$$

$$\text{Ratio} = 0.918$$

Status: **PASS**
Ratio: **0.920**

End-bearing Capacity (ASD)

A - Pile cross-section area

$$A = b D$$

$$A = (48 \text{ in}) \times (48 \text{ in})$$

$$A = 16 \text{ ft}^2$$

q - End-bearing pressure

$$q = \frac{P_c}{A}$$

$$q = \frac{(3.37 \text{ kip})}{(16 \text{ ft}^2)}$$

$$q = 0.21069 \text{ kip/ft}^2$$

$$q = 0.21062 \text{ kip/ft}^2$$

Check bearing capacity ratio:

Ratio - Capacity

$$\text{Ratio} = \frac{q}{q_a}$$

$$\text{Ratio} = \frac{(0.21062 \text{ kip/ft}^2)}{(2000 \text{ psf})}$$

$$\text{Ratio} = 0.10531$$

Status: **PASS**
Ratio: **0.110**

Czerniak

Lateral Soil Pressure (ASD):

L/D - Length to least lateral dimension ratio,

$$L/D = \frac{L}{D}$$

$$L/D = \frac{(6.5 \text{ ft})}{(48 \text{ in})}$$

$$L/D = 1.625$$

Since $L/D \leq 10$,

Pile is short.

Considering x-direction:

$H_o = -0.42277 \text{ kip/ft}$ - Lateral force per length of pile,

$M_o = 4.5482 \text{ kipft/ft}$ - Overturning moment per length of pile,

a - Distance from resting surface to pivot point,

$$a = \frac{(4 M_o L_e) + (3 H_o L_e^2)}{(6 M_o) + (4 H_o L_e)}$$

$$a = \frac{(4 \times (4.5482 \text{ kipft/ft}) \times (6.5 \text{ ft})) + (3 \times (-0.42277 \text{ kip/ft}) \times (6.5 \text{ ft})^2)}{(6 \times (4.5482 \text{ kipft/ft})) + (4 \times (-0.42277 \text{ kip/ft}) \times (6.5 \text{ ft}))}$$

$$a = 4.4889 \text{ ft}$$

p - Earth pressure against the pile at distance $a/2$ from resting surface,

$$p = \frac{0.75 [(4 M_o) + (3 H_o L_e)]^2}{L_e^2 [(3 M_o) + (2 H_o L_e)]}$$

$$p = \frac{0.75 [(4 \times (4.5482 \text{ kipft/ft})) + (3 \times (-0.42277 \text{ kip/ft}) \times (6.5 \text{ ft}))]^2}{(6.5 \text{ ft})^2 [(3 \times (4.5482 \text{ kipft/ft})) + (2 \times (-0.42277 \text{ kip/ft}) \times (6.5 \text{ ft}))]}$$

$$p = 0.21563 \text{ kip/ft}^2$$

s - Earth pressure against the pile at distance L_e ,

$$s = \frac{6 [(2 M_o) + (H_o L_e)]}{L_e^2}$$

$$s = \frac{6 [(2 \times (4.5482 \text{ kipft/ft})) + ((-0.42277 \text{ kip/ft}) \times (6.5 \text{ ft}))]}{(6.5 \text{ ft})^2}$$

$$s = 0.90156 \text{ kip/ft}^2$$

Check lateral soil pressure capacity:

p_a - Allowable lateral soil pressure at depth $a/2$,

$$p_a = R \frac{a}{2}$$

$$p_a = (150 \text{ psf/ft}) \times \frac{(4.4889 \text{ ft})}{2}$$

$$p_a = 0.33666 \text{ kip/ft}^2$$

Ratio - Lateral soil capacity

$$\text{Ratio} = \frac{p}{p_a}$$

$$\text{Ratio} = \frac{(0.21563 \text{ kip/ft}^2)}{(0.33666 \text{ kip/ft}^2)}$$

$$\text{Ratio} = 0.64048$$

p_a - Allowable lateral soil pressure at depth L_e ,

Status: **PASS**
Ratio: **0.640**

$$p_s = R L_e$$

$$p_s = (150 \text{ psf/ft}) \times (6.5 \text{ ft})$$

$$p_s = 0.975 \text{ kip/ft}^2$$

Ratio - Lateral soil capacity

$$\text{Ratio} = \frac{s}{p_s}$$

$$\text{Ratio} = \frac{(0.90156 \text{ kip/ft}^2)}{(0.975 \text{ kip/ft}^2)}$$

$$\text{Ratio} = 0.92468$$

Status: **PASS**
Ratio: **0.920**

Considering z-direction:

$H_o = -0.020541 \text{ kip/ft}$ - Lateral force per length of pile,

$M_o = 0.064968 \text{ kipft/ft}$ - Overturning moment per length of pile,

a - Distance from resting surface to pivot point,

$$a = \frac{(4 M_o L_e) + (3 H_o L_e^2)}{(6 M_o) + (4 H_o L_e)}$$

$$a = \frac{(4 \times (0.064968 \text{ kipft/ft}) \times (6.5 \text{ ft})) + (3 \times (-0.020541 \text{ kip/ft}) \times (6.5 \text{ ft})^2)}{(6 \times (0.064968 \text{ kipft/ft})) + (4 \times (-0.020541 \text{ kip/ft}) \times (6.5 \text{ ft}))}$$

$$a = 4.6465 \text{ ft}$$

p - Earth pressure against the pile at distance $a/2$ from resting surface,

$$p = \frac{0.75 [(4 M_o) + (3 H_o L_e)]^2}{L_e^2 [(3 M_o) + (2 H_o L_e)]}$$

$$p = \frac{0.75 \times [(4 \times (0.064968 \text{ kipft/ft})) + (3 \times (-0.020541 \text{ kip/ft}) \times (6.5 \text{ ft}))]^2}{(6.5 \text{ ft})^2 \times [(3 \times (0.064968 \text{ kipft/ft})) + (2 \times (-0.020541 \text{ kip/ft}) \times (6.5 \text{ ft}))]}$$

$$p = -0.0048707 \text{ kip/ft}^2$$

s - Earth pressure against the pile at distance L_e ,

$$s = \frac{6 [(2 M_o) + (H_o L_e)]}{L_e^2}$$

$$s = \frac{6 \times [(2 \times (0.064968 \text{ kipft/ft})) + ((-0.020541 \text{ kip/ft}) \times (6.5 \text{ ft}))]}{(6.5 \text{ ft})^2}$$

$$s = -0.0005088 \text{ kip/ft}^2$$

Check lateral soil pressure capacity:

p_a - Allowable lateral soil pressure at depth $a/2$,

$$p_a = R \frac{a}{2}$$

$$p_a = (150 \text{ psf/ft}) \times \frac{(4.6465 \text{ ft})}{2}$$

$$p_a = 0.34848 \text{ kip/ft}^2$$

Ratio - Lateral soil capacity

$$\text{Ratio} = \frac{p}{p_a}$$

$$\text{Ratio} = \frac{(-0.0048707 \text{ kip/ft}^2)}{(0.34848 \text{ kip/ft}^2)}$$

$$\text{Ratio} = -0.013977$$

p_s - Allowable lateral soil pressure at depth L_e ,

$$p_s = R L_e$$

$$p_s = (150 \text{ psf/ft}) \times (6.5 \text{ ft})$$

$$p_s = 0.975 \text{ kip/ft}^2$$

Ratio - Lateral soil capacity

$$\text{Ratio} = \frac{s}{p_s}$$

Status: **PASS**
Ratio: **-0.010**

$$\text{Ratio} = \frac{(-0.0005088 \text{ kip/ft}^2)}{(0.975 \text{ kip/ft}^2)}$$

$$\text{Ratio} = -0.00052185$$

Status: **PASS**
Ratio: **0.000**

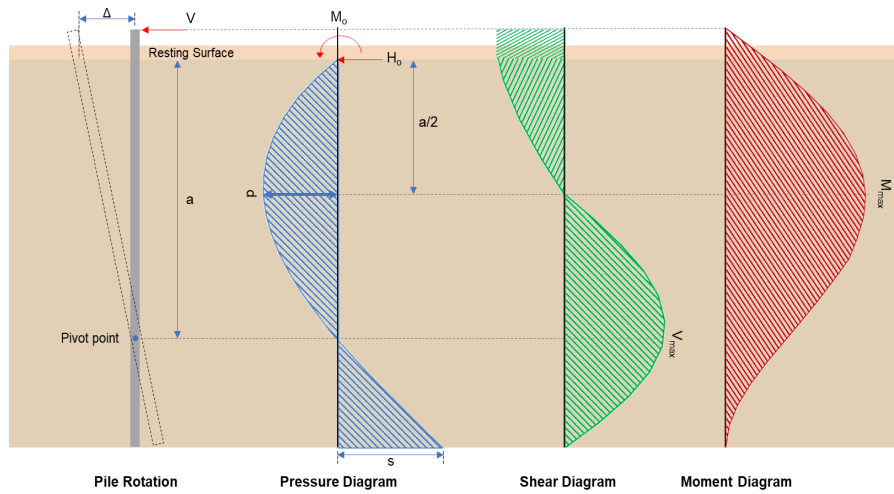

Shear force and Bending moment (x-direction, LRFD)

H_o - Lateral force per length of pile,

$$H_o = \frac{V_e}{1.57 D}$$

$$H_o = \frac{(-4.425 \text{ kip})}{1.57 \times (48 \text{ in})}$$

$$H_o = -0.70462 \text{ kip/ft}$$

M_o - Moment per length of pile,

$$M_o = \frac{M_z + (V_x H)}{1.57 D}$$

$$M_o = \frac{(48.166 \text{ kipft}) + ((-4.425 \text{ kip}) \times (0 \text{ ft}))}{1.57 \times (48 \text{ in})}$$

$$M_o = 7.6697 \text{ kipft/ft}$$

E - Distance from lateral load to resisting surface,

$$E = \frac{M_o}{H_o}$$

$$E = \frac{(7.6697 \text{ kipft/ft})}{(-0.70462 \text{ kip/ft})}$$

$$E = 10.885 \text{ ft}$$

a - Distance from resting surface to pivot point,

$$a = \frac{(4 M_o L_e) + (3 H_o L_e^2)}{(6 M_o) + (4 H_o L_e)}$$

$$a = \frac{(4 \times (7.6697 \text{ kipft/ft}) \times (6.5 \text{ ft})) + (3 \times (-0.70462 \text{ kip/ft}) \times (6.5 \text{ ft})^2)}{(6 \times (7.6697 \text{ kipft/ft})) + (4 \times (-0.70462 \text{ kip/ft}) \times (6.5 \text{ ft}))}$$

$$a = 4.4876 \text{ ft}$$

V_{max} - Max shear force located at depth a ,

$$V_{max} = (H_o D) \left[1 - \left[3 \left(\frac{4 E}{L_e} + 3 \right) \left(\frac{a}{L_e} \right)^2 \right] + \left[4 \left(\frac{3 E}{L_e} + 2 \right) \left(\frac{a}{L_e} \right)^3 \right] \right]$$

$$V_{max} = ((-0.70462 \text{ kip/ft}) \times (48 \text{ in})) \times \left[1 - \left[3 \times \left(\frac{4 \times (10.885 \text{ ft})}{(6.5 \text{ ft})} + 3 \right) \times \left(\frac{(4.4876 \text{ ft})}{(6.5 \text{ ft})} \right)^2 \right] + \left[4 \times \left(\frac{3 \times (10.885 \text{ ft})}{(6.5 \text{ ft})} + 2 \right) \times \left(\frac{(4.4876 \text{ ft})}{(6.5 \text{ ft})} \right)^3 \right] \right]$$

$$V_{max} = 10.211 \text{ kip}$$

M_{max} - Max bending moment located at depth $a/2$,

$$M_{max} = (H_o D L_e) \left[\left(\frac{E}{L_e} + \frac{a}{2 L_e} \right) - \left[\left(\frac{4E}{L_e} + 3 \right) \left(\frac{a}{2 L_e} \right)^3 \right] + \left[\left(\frac{3E}{L_e} + 2 \right) \left(\frac{a}{2 L_e} \right)^4 \right] \right]$$

$$M_{max} = ((-0.70462 \text{ kip/ft}) \times (48 \text{ in}) \times (6.5 \text{ ft})) \times \left[\left(\frac{(10.885 \text{ ft})}{(6.5 \text{ ft})} + \frac{(4.4876 \text{ ft})}{2 \times (6.5 \text{ ft})} \right) - \left[\left(\frac{4 \times (10.885 \text{ ft})}{(6.5 \text{ ft})} + 3 \right) \times \left(\frac{(4.4876 \text{ ft})}{2 \times (6.5 \text{ ft})} \right)^3 \right] + \left[\left(\frac{3 \times (10.885 \text{ ft})}{(6.5 \text{ ft})} + 2 \right) \times \left(\frac{(4.4876 \text{ ft})}{2 \times (6.5 \text{ ft})} \right)^4 \right] \right]$$

$$M_{max} = 31.522 \text{ kipft}$$

Shear force and Bending moment (z-direction, LRFD)

H_o - Lateral force per length of pile,

$$H_o = \frac{V_z}{1.57 b}$$

$$H_o = \frac{(-0.197 \text{ kip})}{1.57 \times (48 \text{ in})}$$

$$H_o = -0.031369 \text{ kip/ft}$$

M_o - Moment per length of pile,

$$M_o = \frac{M_x + (V_z H)}{1.57 b}$$

$$M_o = \frac{(0.62 \text{ kipft}) + ((-0.197 \text{ kip}) \times (0 \text{ ft}))}{1.57 \times (48 \text{ in})}$$

$$M_o = 0.098726 \text{ kipft/ft}$$

E - Distance from lateral load to resisting surface,

$$E = \frac{M_o}{H_o}$$

$$E = \frac{(0.098726 \text{ kipft/ft})}{(-0.031369 \text{ kip/ft})}$$

$$E = 3.1472 \text{ ft}$$

a - Distance from resting surface to pivot point,

$$a = \frac{(4 M_o L_e) + (3 H_o L_e^2)}{(6 M_o) + (4 H_o L_e)}$$

$$a = \frac{(4 \times (0.098726 \text{ kipft/ft}) \times (6.5 \text{ ft})) + (3 \times (-0.031369 \text{ kip/ft}) \times (6.5 \text{ ft})^2)}{(6 \times (0.098726 \text{ kipft/ft})) + (4 \times (-0.031369 \text{ kip/ft}) \times (6.5 \text{ ft}))}$$

$$a = 4.6471 \text{ ft}$$

V_{max} - Max shear force located at depth a ,

$$V_{max} = (H_o b) \left[1 - \left[3 \left(\frac{4E}{L_e} + 3 \right) \left(\frac{a}{L_e} \right)^2 \right] + \left[4 \left(\frac{3E}{L_e} + 2 \right) \left(\frac{a}{L_e} \right)^3 \right] \right]$$

$$V_{max} = ((-0.031369 \text{ kip/ft}) \times (48 \text{ in})) \times \left[1 - \left[3 \times \left(\frac{4 \times (3.1472 \text{ ft})}{(6.5 \text{ ft})} + 3 \right) \times \left(\frac{(4.6471 \text{ ft})}{(6.5 \text{ ft})} \right)^2 \right] + \left[4 \times \left(\frac{3 \times (3.1472 \text{ ft})}{(6.5 \text{ ft})} + 2 \right) \times \left(\frac{(4.6471 \text{ ft})}{(6.5 \text{ ft})} \right)^3 \right] \right]$$

$$V_{max} = 0.19115 \text{ kip}$$

M_{max} - Max bending moment located at depth $a/2$,

$$M_{max} = (H_o b L_e) \left[\left(\frac{E}{L_e} + \frac{a}{2 L_e} \right) - \left[\left(\frac{4E}{L_e} + 3 \right) \left(\frac{a}{2 L_e} \right)^3 \right] + \left[\left(\frac{3E}{L_e} + 2 \right) \left(\frac{a}{2 L_e} \right)^4 \right] \right]$$

$$M_{max} = ((-0.031369 \text{ kip/ft}) \times (48 \text{ in}) \times (6.5 \text{ ft})) \times \left[\left(\frac{(3.1472 \text{ ft})}{(6.5 \text{ ft})} + \frac{(4.6471 \text{ ft})}{2 \times (6.5 \text{ ft})} \right) - \left[\left(\frac{4 \times (3.1472 \text{ ft})}{(6.5 \text{ ft})} + 3 \right) \times \left(\frac{(4.6471 \text{ ft})}{2 \times (6.5 \text{ ft})} \right)^3 \right] + \left[\left(\frac{3 \times (3.1472 \text{ ft})}{(6.5 \text{ ft})} + 2 \right) \times \left(\frac{(4.6471 \text{ ft})}{2 \times (6.5 \text{ ft})} \right)^4 \right] \right]$$

$$M_{max} = 0.54852 \text{ kipft}$$

Minimum Reinforcement Check (LRFD)

Parameters:

$f'_{ck} = 3 \text{ ksi}$ - Concrete strength,
 $f_{yk} = 60 \text{ ksi}$ - Longitudinal reinforcement strength,
 $\phi = 0.65$ - Reduction factor for axial strength,
 $\alpha = 0.8$ - Alpha factor for axial strength,
 $A_g = 2304 \text{ in}^2$ - Gross area of concrete,

Table 22.4.2.1

Longitudinal reinforcement:

Required reinforcement due to axial load, $A_{st,required}$

22.4.2.2, 10.6.1.1

$A_{st,required}$

$$A_{st,required} = \text{Min} \left[\frac{\frac{P}{\phi \alpha} - (0.85 f'_{ck} A_g)}{f_{yk} - (0.85 f'_{ck})}, (0.08 A_g) \right]$$

$$A_{st,required} = \text{Min} \left[\frac{\frac{(4.828 \text{ kip})}{(0.65) \times (0.8)} - (0.85 \times (3 \text{ ksi}) \times (2304 \text{ in}^2))}{(60 \text{ ksi}) - (0.85 \times (3 \text{ ksi}))}, (0.08 \times (2304 \text{ in}^2)) \right]$$

$$A_{st,required} = -102.1 \text{ in}^2$$

A_{min} - Governing minimum reinforcement area,

$$A_{min} = \text{Max} [A_{st,required}, (0.0018 A_g)]$$

$$A_{min} = \text{Max} [(-102.1 \text{ in}^2), (0.0018 \times (2304 \text{ in}^2))]$$

$$A_{min} = 4.1472 \text{ in}^2$$

n_{rebar} - Required number of reinforcement,

$$n_{rebar} = \frac{A_{min}}{A_{rebar}}$$

$$n_{rebar} = \frac{(4.1472 \text{ in}^2)}{(0.3068 \text{ in}^2)}$$

$$n_{rebar} = 14$$

A_{st} - Actual total reinforcement area,

$$A_{st} = n_{rebar} \frac{\pi d_{bar}^2}{4}$$

$$A_{st} = (14) \times \frac{\pi \times (0.625 \text{ in})^2}{4}$$

$$A_{st} = 4.2951 \text{ in}^2$$

Ratio - Capacity

$$\text{Ratio} = \frac{A_{min}}{A_{st}}$$

$$\text{Ratio} = \frac{(4.1472 \text{ in}^2)}{(4.2951 \text{ in}^2)}$$

$$\text{Ratio} = 0.96556$$

Status: **PASS**
Ratio: **0.970**

25.2.3

s_{rebar} - Minimum spacing of reinforcement,

$$s_{rebar} = \text{Max} [1.5, (1.5 d_{bar})]$$

$$s_{rebar} = \text{Max} [1.5, (1.5 \times (0.625 \text{ in}))]$$

$$s_{rebar} = 1.5 \text{ in}$$

Ties:

25.7.2.2 Since longitudinal reinforcement is \leq No. 10: Use #3(0.375 in)

25.7.2.1 s_{ties} - Maximum spacing of ties,

$$s_{ties} = \text{Min} [(16 d_{bar}), (48 d_{ties}), \text{Min} (D, b)]$$

$$s_{ties} = \text{Min} [(16 \times (0.625 \text{ in})), (48 \times (0.375 \text{ in})), \text{Min} ((48 \text{ in}), (48 \text{ in}))]$$

$$s_{ties} = 10 \text{ in}$$

Summary:

Main reinforcement: **14 - #5 (0.625 in)**

Ties: #3(0.375 in) - 10 in

Axial Compression Strength (ACI 318-19, LRFD)

22.4.2.2

ϕP_N - Allowable axial compressive strength

$$\phi P_N = \phi 0.80 [(0.85 f'_{ck} [A_g - A_{st}]) + (f_{yk} A_{st})]$$

$$\phi P_N = (0.65) \times 0.80 \times [(0.85 \times (3 \text{ ksi}) \times [(2304 \text{ in}^2) - (4.2951 \text{ in}^2)]) + ((60 \text{ ksi}) \times (4.2951 \text{ in}^2))]$$

$$\phi P_N = 3183.4 \text{ kip}$$

Ratio - Capacity

$$\text{Ratio} = \frac{P}{\phi P_N}$$

$$\text{Ratio} = \frac{(4.828 \text{ kip})}{(3183.4 \text{ kip})}$$

$$\text{Ratio} = 0.0015166$$

Status: **PASS**
Ratio: **0.000**

Shear Strength (ACI 318-19, LRFD)

Parameters:

22.5.2.2

$b_w = 48 \text{ in}$ - Effective width,
 d - Effective depth

$$d = 0.80 D$$

$$d = 0.80 \times (48 \text{ in})$$

$$d = 38.4 \text{ in}$$

22.5.5.1.3

λ_s - size effect modification factor

$$\lambda_s = \text{MIN} \left[\sqrt{\frac{2}{1 + \frac{d}{10}}}, 1 \right]$$

$$\lambda_s = \text{MIN} \left[\sqrt{\frac{2}{1 + \frac{(38.4 \text{ in})}{10}}}, 1 \right]$$

$$\lambda_s = 0.64282$$

22.5.5.1.1

The following variables were converted to be consistent with empirical formula $f'_{ck} = 3 \text{ ksi} \rightarrow 3000 \text{ psi}$,
 $V_{c,max}$ - Max shear strength of concrete

$$V_{c,max} = 5 \lambda_s \sqrt{f'_{ck}} b_w d$$

$$V_{c,max} = 5 \times (0.64282) \times \sqrt{(3000 \text{ psi})} \times (48 \text{ in}) \times (38.4 \text{ in})$$

$$V_{c,max} = 324.49 \text{ kip}$$

22.5.5.1.1(a)

The following variables were converted to be consistent with empirical formula $f'_{ck} = 3 \text{ ksi} \rightarrow 3000 \text{ psi}$, $P = 4.828 \text{ kip} \rightarrow 4828 \text{ lbf}$,
 $V_{c,a}$ - Shear strength of concrete (a)

$$V_{c,a} = \left[2 \lambda_s \sqrt{f'_{ck}} + \frac{P}{6 A_g} \right] b_w d$$

$$V_{c,a} = \left[2 \times (0.64282) \times \sqrt{(3000 \text{ psi})} + \frac{(4828 \text{ lbf})}{6 \times (2304 \text{ in}^2)} \right] \times (48 \text{ in}) \times (38.4 \text{ in})$$

$$V_{c,a} = 130.44 \text{ kip}$$

22.5.5.1.2

The following variables were converted to be consistent with empirical formula $f'_{ck} = 3 \text{ ksi} \rightarrow 3000 \text{ psi}$,
 $V_{c,b}$ - Shear strength of concrete (b)

$$V_{c,b} = \left[2 \lambda_s \sqrt{f'_{ck}} + (0.05 f'_{ck}) \right] b_w d$$

$$V_{c,b} = \left[2 \times (0.64282) \times \sqrt{(3000 \text{ psi})} + (0.05 \times (3000 \text{ psi})) \right] \times (48 \text{ in}) \times (38.4 \text{ in})$$

$$V_{c,b} = 406.27 \text{ kip}$$

V_c - Governing shear strength of concrete

$$V_c = \text{Min}[V_{c,max}, V_{c,a}, V_{c,b}]$$

$$V_c = \text{Min}[(324.49 \text{ kip}), (130.44 \text{ kip}), (406.27 \text{ kip})]$$

$$V_c = 130.44 \text{ kip}$$

<p>22.5.1.2</p>	<p>The following variables were converted to be consistent with empirical formula $f'_{ck} = 3 \text{ ksi} \rightarrow 3000 \text{ psi}$, $V_{s,a}$ - Shear strength of steel (a)</p> $V_{s,a} = 8 \sqrt{f'_{ck}} b_w d$ $V_{s,a} = 8 \times \sqrt{(3000 \text{ psi})} \times (48 \text{ in}) \times (38.4 \text{ in})$ $V_{s,a} = 807.65 \text{ kip}$ <p>A_v - Ties rebar area,</p> $A_v = \frac{\pi d_{ties}^2}{4}$ $A_v = \frac{\pi \times (0.375 \text{ in})^2}{4}$ $A_v = 0.11045 \text{ in}^2$ <p>22.5.8.5.3 $V_{s,b}$ - Shear strength of steel (b)</p> $V_{s,b} = \frac{2 A_v f_{yt} d}{s_{ties}}$ $V_{s,b} = \frac{2 \times (0.11045 \text{ in}^2) \times (60 \text{ ksi}) \times (38.4 \text{ in})}{(10 \text{ in})}$ $V_{s,b} = 50.894 \text{ kip}$ <p>V_s - Governing shear strength of steel</p> $V_s = \text{MIN}[V_{s,a}, V_{s,b}]$ $V_s = \text{MIN}[(807.65 \text{ kip}), (50.894 \text{ kip})]$ $V_s = 50.894 \text{ kip}$ <p>22.5.1.1 ϕV_n - Allowable shear strength</p> $\phi V_n = \phi (V_c + V_s)$ $\phi V_n = (0.65) \times ((130.44 \text{ kip}) + (50.894 \text{ kip}))$ $\phi V_n = 117.87 \text{ kip}$ <p>Considering x-direction:</p> <p>$V_{max} = 10.211 \text{ kip}$ - Maximum shear force in the x-direction, Ratio - Capacity</p> $\text{Ratio} = \frac{V_{max}}{\phi V_n}$ $\text{Ratio} = \frac{(10.211 \text{ kip})}{(117.87 \text{ kip})}$ $\text{Ratio} = 0.086629$ <p>Considering z-direction:</p> <p>$V_{max} = 0.19115 \text{ kip}$ - Maximum shear force in the z-direction, Ratio - Capacity</p> $\text{Ratio} = \frac{V_{max}}{\phi V_n}$ $\text{Ratio} = \frac{(0.19115 \text{ kip})}{(117.87 \text{ kip})}$ $\text{Ratio} = 0.0016217$	<p>Status: PASS Ratio: 0.090</p> <p>Status: PASS Ratio: 0.000</p>
	<p>Flexural Strength (ACI 318-19, LFRD)</p> <p>S_m - Section modulus</p> $S_m = \frac{b D^2}{6}$ $S_m = \frac{(48 \text{ in}) \times (48 \text{ in})^2}{6}$ $S_m = 18432 \text{ in}^3$	

<p>14.5.2.1b</p>	<p>$\lambda = 1$ - Concrete modification factor (Normal concrete), Allowable flexural strength: M_n shall be the lesser of: $\phi M_{n,1}$</p> $\phi M_{n,1} = \phi \times 5 \times \lambda \times \sqrt{f'_c} \times S_m$ $\phi M_{n,1} = 0.65 \times 5 \times 1 \times \sqrt{3ksi} \times 18432.001 in^3$ $\phi M_{n,1} = 273.423 kipft$ <p>$\phi M_{n,2}$</p> $\phi M_{n,2} = \phi \times 0.85 \times f'_c \times S_m$ $\phi M_{n,2} = (0.65) \times 0.85 \times (3 ksi) \times (18432 in^3)$ $\phi M_{n,2} = 2545.9 kipft$ <p>Therefore, ϕM_n - Allowable flexural strength,</p> $\phi M_n = MIN[\phi M_{n,1}, \phi M_{n,2}]$ $\phi M_n = MIN[(273.42 kipft), (2545.9 kipft)]$ $\phi M_n = 273.42 kipft$ <p>Considering x-direction: $M_{max} = 31.522 kipft$ - Maximum moment in the x-direction, Ratio - Capacity</p> $Ratio = \frac{M_{max}}{\phi M_n}$ $Ratio = \frac{(31.522 kipft)}{(273.42 kipft)}$ $Ratio = 0.11529$	<p>Status: PASS Ratio: 0.120</p>
	<p>Considering z-direction: $M_{max} = 0.54852 kipft$ - Maximum moment in the z-direction, Ratio - Capacity</p> $Ratio = \frac{M_{max}}{\phi M_n}$ $Ratio = \frac{(0.54852 kipft)}{(273.42 kipft)}$ $Ratio = 0.0020061$	<p>Status: PASS Ratio: 0.000</p>