

Your Project Calculations



Project Name: MTSOLAR_Rott

S3D Model Link:

https://platform.skyciv.com/structural?preload_name=MTSOLAR_Rott&preload_path=Shared%20Enterprise%20Folder/MT_Solar_Projects/4_2023

Public Model Link:

https://platform.skyciv.com/structural-viewer?project_id=OGgxYvCRKgDVTXlq3UKjTO7ahDyYW6f74grfkykEk2d2gasZYsw7Met5hujM7WV

Array Specification

| | |
|------------------------------------|------------------------------|
| Product: | Beam |
| Unique ID: | 1P-0-8TOP-HD-84-L-5Hx4W-87DI |
| Duty Classification: | HD |
| Module Width: | 39.40 in |
| Module Length: | 66.30in |
| Number of Rows: | 5 |
| Number of Columns: | 4 |
| Total Number of Modules: | 20 |
| Desired Tilt Angle: | 30 |
| Front Edge Clearance: | 7 |
| Total Array Height at Tilt: | 15.26 ft |
| Total Frame Length: | 21.50 ft |
| Frame Weight: | 964 lbs |
| Array Dimensions N/S: | 16.63 ft |
| Array Dimensions E/W: | 22.43 ft |
| Rail Length: | 199.50 in |
| Rail Spacing: | 2.76 ft |
| Rail Check: | Not Checked |

Support Specifications

| | |
|---------------------------------|-----------------|
| Pole Size: | 8in Pipe Sch 40 |
| Pole Length above Grade: | 11.16 ft |
| Number of Poles: | 1 |
| Pole Spacing: | 0 |

Foundation Specifications

| | |
|--|----------------------|
| Foundation Type: | Square |
| Foundation Dimensions: | 48 x 48 in |
| Foundation Depth (below grade): | Pile 1: 6.50 ft |
| Foundation Volume: | 3.852 y ³ |
| Foundation Result: | PASSED |
| Mount Twist: | 0.000005 kip |

Site Info

| | |
|-----------------------------------|--|
| Risk Category: | I |
| Exposure: | B |
| Soil Classification: | sand |
| Site Location: | 4817 N Waynesville Rd, Oregonia, OH 45054, USA |
| Wind Speed: | 100 mph |
| Snow Load: | 20 psf |
| Design Uplift Pressure: | Multiple pressures |
| Design Downforce Pressure: | Multiple pressures |
| Design Snow Pressure: | 0.008797 ksf |



Design Disclaimer

This software should be used for preliminary designs and should not be used as a final design unless reviewed, verified and designed by a qualified structural engineer.

AutoDesigner Input

```
{
  "wind_speed_override": null,
  "snow_load_override": null,
  "direct_snow_load": false,
  "product_type": "Beam",
  "project_id": "MTSOLAR_Rott",
  "site_address": "4817 N Waynesville Rd, Oregonia, OH 45054, USA",
  "module_width": 39.4,
  "module_length": 66.3,
  "number_rows": 5,
  "number_columns": 4,
  "pole_mount_section": "4_40",
  "core_pipe_width": 65,
  "core_pipe_section": "2_40",
  "adjuster_section": "2_40",
  "core_beam_height": 65,
  "core_beam_section": "HSS3x2x1/8",
  "main_pipe_section": "2_12GA",
  "pole_spacing": 15,
  "tilt_angle": 30,
  "ground_clearance": 7,
  "risk_category": "I",
  "exposure_category": "B",
  "frame_duty_override": "auto",
  "pole_override": "auto",
  "soil_type": "sand",
  "foundation_type": "Square",
  "foundation_size": 48,
  "check_rails": false
}
```

Design Notes:

- AISC Deflection checks are set to L/1 due to structure design intent
- Foundation Design and Sizing is approximate only

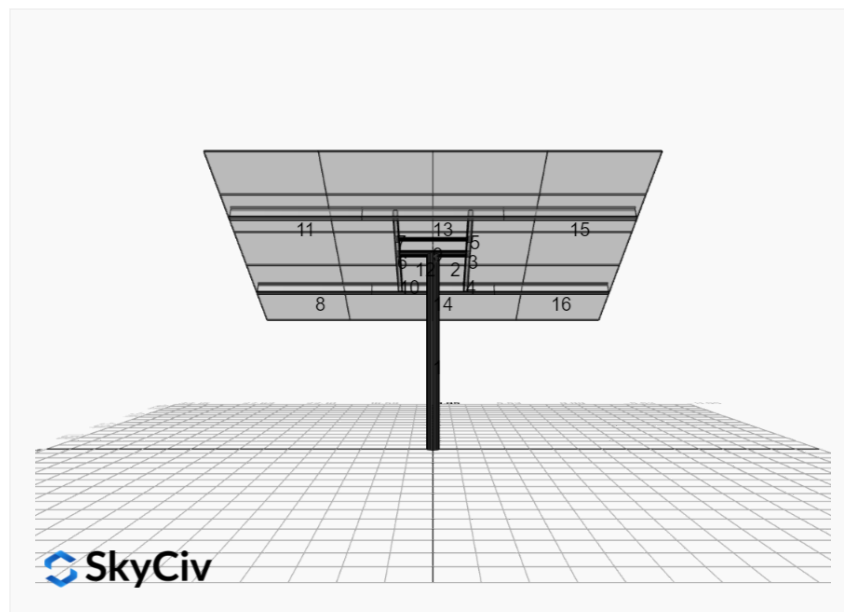

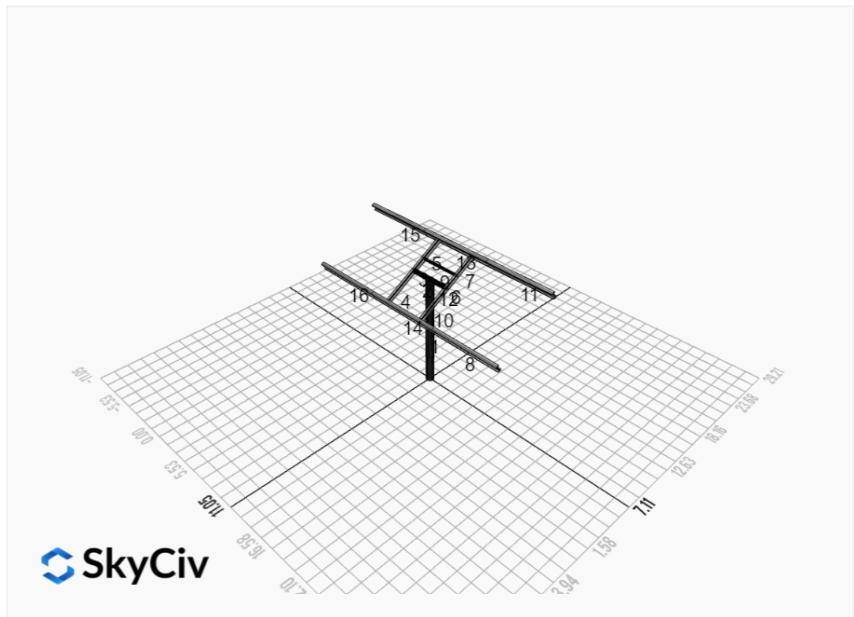
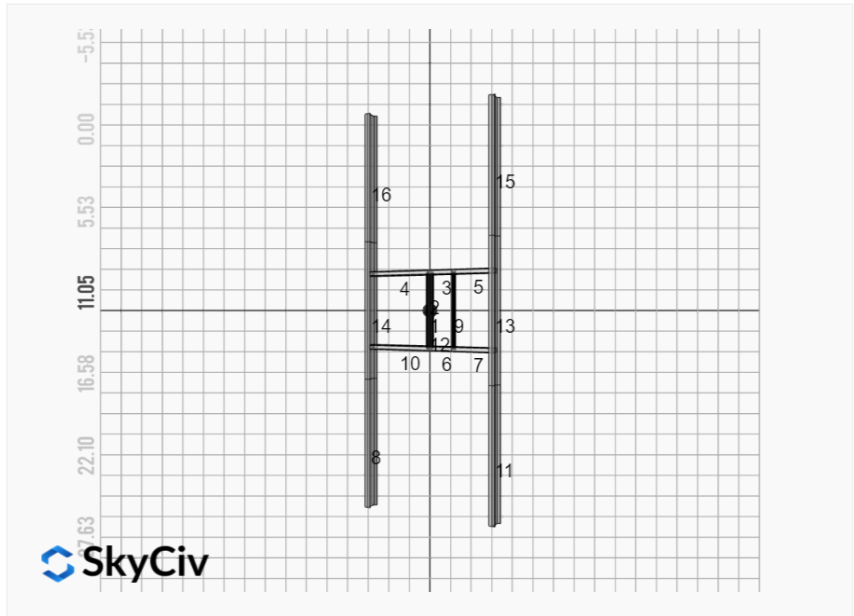
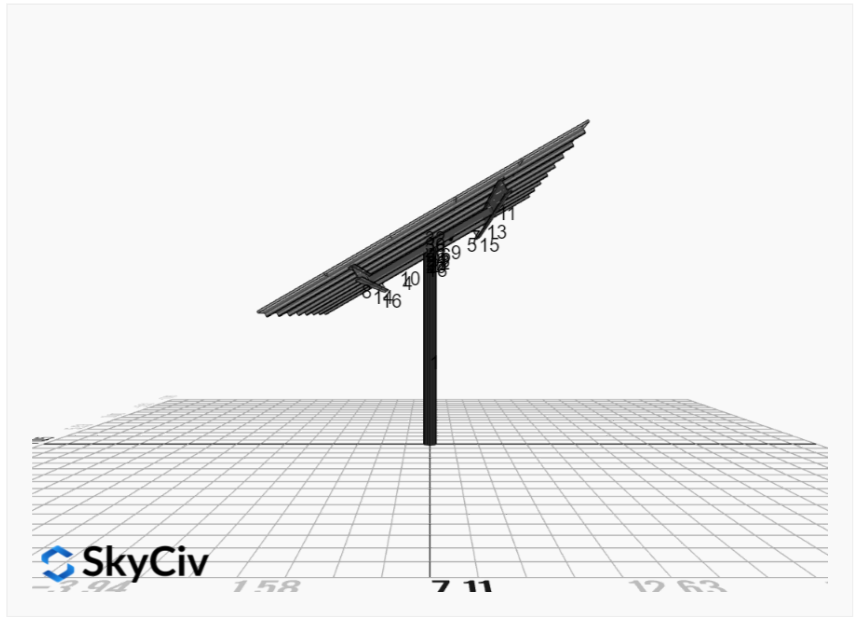

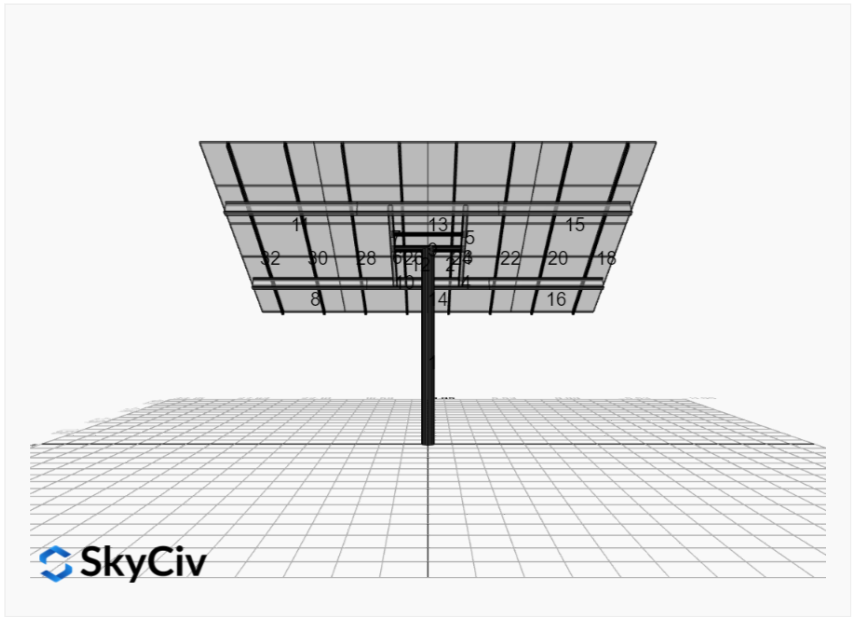

FEM Results (Envelope Worst Case for each member)

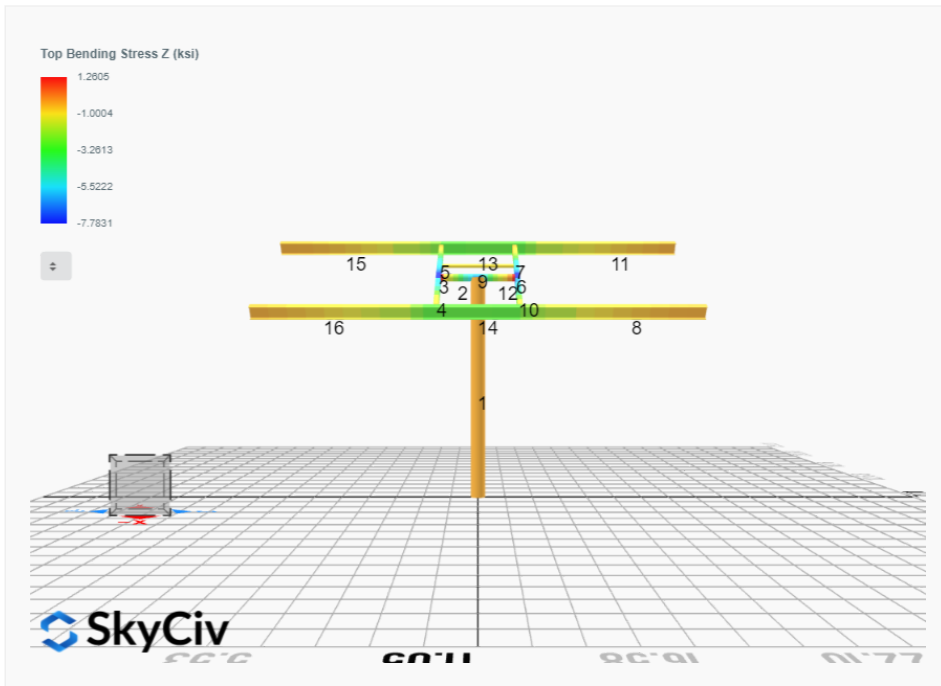
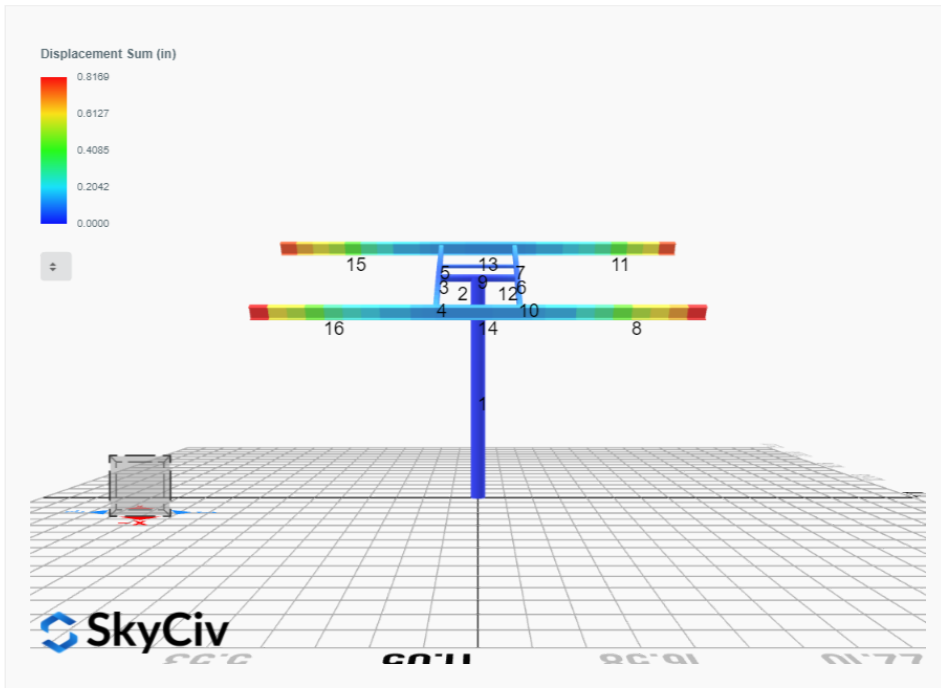

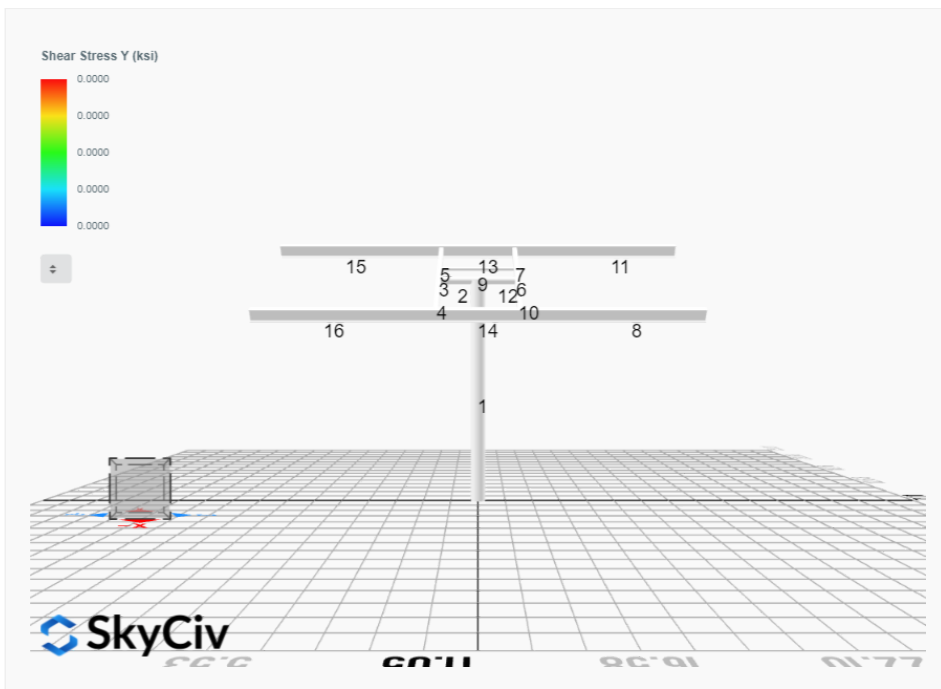
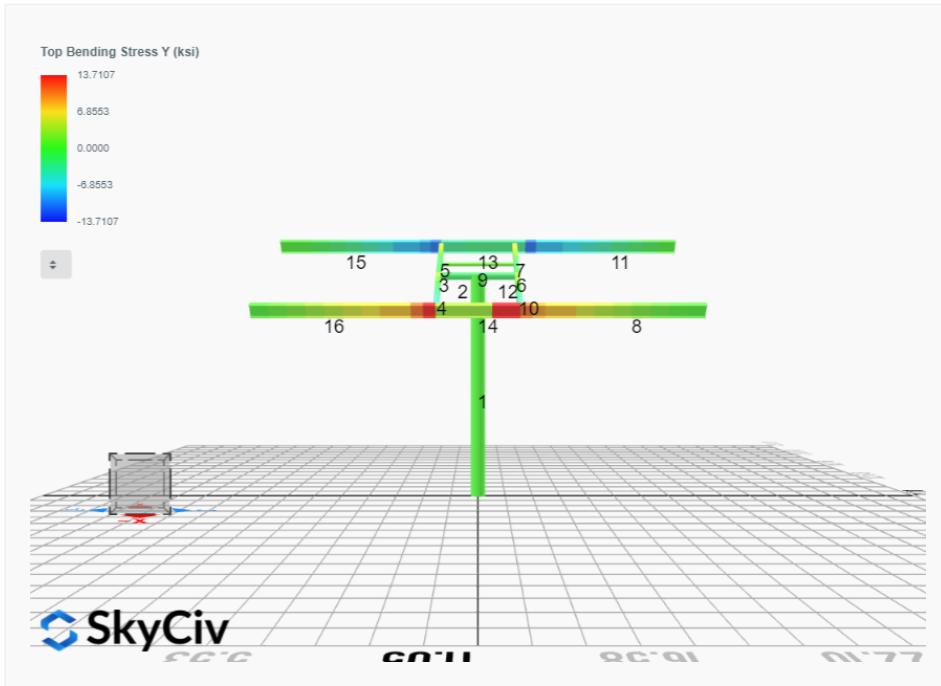

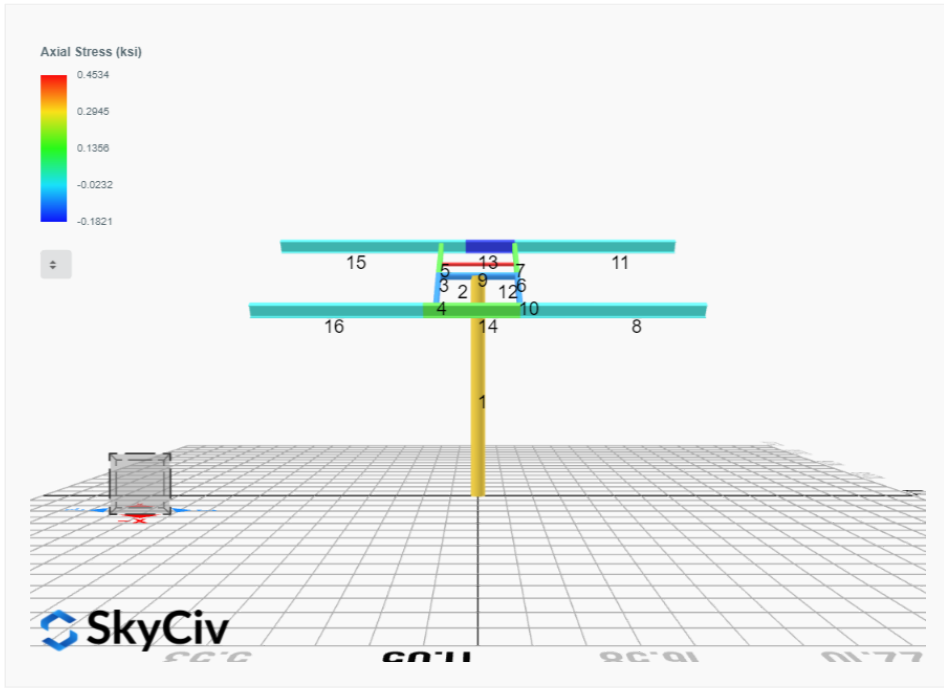

Reaction Forces for Foundation 1 (Node ID#1), (kip, kip-ft)

ASD Load Combination Results

| Name | Fx | Fy | Fz | Mx | My | Mz |
|---|---------|---------|---------|--------|---------|----------|
| ULS: 1. D | -0.0000 | 2.6956 | -0.0000 | 0.0000 | -0.0000 | 0.0284 |
| ULS: 2. D + L | -0.0000 | 2.6956 | -0.0000 | 0.0000 | -0.0000 | 0.0284 |
| ULS: 3. D + (S or Lr or R) | -0.0000 | 5.4187 | -0.0000 | 0.0000 | -0.0000 | 0.0367 |
| ULS: 3. D + (S or Lr or R) | -0.0000 | 2.6956 | -0.0000 | 0.0000 | -0.0000 | 0.0284 |
| ULS: 4. D + 0.75L + 0.75(S or Lr or R) | -0.0000 | 4.7379 | -0.0000 | 0.0000 | -0.0000 | 0.0346 |
| ULS: 4. D + 0.75L + 0.75(S or Lr or R) | -0.0000 | 2.6956 | -0.0000 | 0.0000 | -0.0000 | 0.0284 |
| ULS: 5b. D + 0.7E | -0.0000 | 2.6956 | -0.0000 | 0.0000 | -0.0000 | 0.0284 |
| ULS: 6b. D + 0.75L + 0.75(0.7)E + 0.75S | -0.0000 | 4.7379 | -0.0000 | 0.0000 | -0.0000 | 0.0346 |
| ULS: 8. 0.6D + 0.7E | -0.0000 | 1.6173 | -0.0000 | 0.0000 | -0.0000 | 0.0170 |
| ULS: 5a. D + 0.6W_Wind downforce Case A only | -2.4239 | 6.8940 | 0.0000 | 0.0000 | -0.0000 | 27.6214 |
| ULS: 5a. D + 0.6W_Wind downforce Case B only | -2.4239 | 6.8940 | 0.0000 | 0.0000 | -0.0000 | 27.6214 |
| ULS: 5a. D + 0.6W_Wind uplift Case A only | 2.0777 | -0.9031 | -0.0000 | 0.0000 | -0.0000 | -22.7634 |
| ULS: 5a. D + 0.6W_Wind uplift Case B only | 1.7314 | -0.3033 | -0.0000 | 0.0000 | -0.0000 | -27.4934 |
| ULS: 6a. D + 0.75L + 0.75(0.6)W + 0.75(S or Lr or R)_Wind downforce Case A only | -1.8180 | 7.8867 | -0.0000 | 0.0000 | -0.0000 | 20.7294 |
| ULS: 6a. D + 0.75L + 0.75(0.6)W + 0.75(S or Lr or R)_Wind downforce Case B only | -1.8180 | 7.8867 | -0.0000 | 0.0000 | -0.0000 | 20.7294 |
| ULS: 6a. D + 0.75L + 0.75(0.6)W + 0.75(S or Lr or R)_Wind uplift Case A only | 1.5583 | 2.0389 | -0.0000 | 0.0000 | -0.0000 | -17.0593 |
| ULS: 6a. D + 0.75L + 0.75(0.6)W + 0.75(S or Lr or R)_Wind uplift Case B only | 1.2985 | 2.4888 | -0.0000 | 0.0000 | -0.0000 | -20.6067 |
| ULS: 6a. D + 0.75L + 0.75(0.6)W + 0.75(S or Lr or R)_Wind downforce Case A only | -1.8180 | 5.8444 | -0.0000 | 0.0000 | -0.0000 | 20.7232 |
| ULS: 6a. D + 0.75L + 0.75(0.6)W + 0.75(S or Lr or R)_Wind downforce Case B only | -1.8180 | 5.8444 | -0.0000 | 0.0000 | -0.0000 | 20.7232 |
| ULS: 6a. D + 0.75L + 0.75(0.6)W + 0.75(S or Lr or R)_Wind uplift Case A only | 1.5583 | -0.0034 | -0.0000 | 0.0000 | -0.0000 | -17.0655 |
| ULS: 6a. D + 0.75L + 0.75(0.6)W + 0.75(S or Lr or R)_Wind uplift Case B only | 1.2985 | 0.4464 | -0.0000 | 0.0000 | -0.0000 | -20.6130 |
| ULS: 7. 0.6D + 0.6W_Wind downforce Case A only | -2.4239 | 5.8157 | 0.0000 | 0.0000 | -0.0000 | 27.6101 |
| ULS: 7. 0.6D + 0.6W_Wind downforce Case B only | -2.4239 | 5.8157 | 0.0000 | 0.0000 | -0.0000 | 27.6101 |
| ULS: 7. 0.6D + 0.6W_Wind uplift Case A only | 2.0777 | -1.9813 | -0.0000 | 0.0000 | -0.0000 | -22.7748 |
| ULS: 7. 0.6D + 0.6W_Wind uplift Case B only | 1.7314 | -1.3815 | -0.0000 | 0.0000 | -0.0000 | -27.5048 |

Worst Case Reactions LRFD

These calculations are taken directly from the FEA via SkyCiv and are used in the Concrete Checks of the Foundation Module.
Note: Worst case values are assumed as downforce wind load cases.

| Result | Value (kip, kip-ft) |
|------------------|---------------------|
| Axial | 11.5936 |
| Shear X | -4.0399 |
| Shear Z | 0.0000 |
| Moment X | -0.0000 |
| Moment Y (Twist) | 0.0000 |
| Moment Z | 46.7108 |

Worst Case Reactions ASD

These results are taken from the worst case values in the above table and are used in the Soil Checks in the Foundation Module.
Note: Worst case values are assumed as downforce wind load cases.

| Result | Value (kip, kip-ft) |
|------------------|---------------------|
| Axial | 7.8867 |
| Shear X | -2.4239 |
| Shear Z | -0.0000 |
| Moment X | 0.0000 |
| Moment Y (Twist) | 0.0000 |
| Moment Z | 27.6214 |

Project Details

Design Code: AISC 360-16 LRFD
 Provision: LRFD
 Country: United States

User Name: sales@mtsolar.us
 Project Name: MTSOLAR_Rott
 Unit System: imperial



Design Input Information

| Design Factors | | | |
|----------------|----------|----------|----------|
| Φ_t | Φ_c | Φ_b | Φ_v |
| 0.9 | 0.9 | 0.9 | 0.9 |

| Design Materials | | | |
|------------------|---------|----------------------|----------------------|
| ID | E (ksi) | F _y (ksi) | F _u (ksi) |
| 1 | 29000 | 50 | 65 |

Section Dimensions

| ID | Name | d (in) | t _w (in) | | | | |
|----|-----------------|--------|---------------------|--|--|--|--|
| 2 | 2in Pipe Sch 80 | 2.38 | 0.22 | | | | |
| 5 | 4in Pipe Sch 80 | 4.50 | 0.34 | | | | |
| 9 | 8in Pipe Sch 40 | 8.63 | 0.32 | | | | |

| ID | Name | d (in) | b (in) | t _w (in) | t _b (in) | r (in) | |
|----|-------------|--------|--------|---------------------|---------------------|--------|--|
| 16 | HSS5x3x3/16 | 5.00 | 3.00 | 0.17 | 0.17 | 0.17 | |

| ID | Name | d (in) | t _w (in) | b _t (in) | b _b (in) | t _t (in) | t _b (in) | r (in) |
|----|-------|--------|---------------------|---------------------|---------------------|---------------------|---------------------|--------|
| 19 | W8x10 | 7.89 | 0.17 | 3.94 | 3.94 | 0.20 | 0.20 | 0.30 |

| Section Properties | | | | | | | | |
|--------------------|-----------------|----------------------|----------------------|------------------------------------|------------------------------------|-----------------------------------|------------------------------------|------------------------------------|
| ID | Name | A (in ²) | J (in ⁴) | I _{yp} (in ⁴) | I _{zp} (in ⁴) | I _w (in ⁶) | S _{yp} (in ³) | S _{zp} (in ³) |
| 2 | 2in Pipe Sch 80 | 1.48 | 1.74 | 0.87 | 0.87 | 0.00 | 1.02 | 1.02 |
| 5 | 4in Pipe Sch 80 | 4.41 | 19.22 | 9.61 | 9.61 | 0.00 | 5.85 | 5.85 |

| | | | | | | |
|----|--------|--------|-------|-------|-------|-------|
| 10 | 116.10 | 111.33 | 15.79 | 11.10 | 42.08 | 23.28 |
| 11 | 133.20 | 15.17 | 32.87 | 6.12 | 40.24 | 43.62 |
| 12 | 198.33 | 196.72 | 21.95 | 21.95 | 59.50 | 59.50 |
| 13 | 133.20 | 104.94 | 23.37 | 6.12 | 40.24 | 43.62 |
| 14 | 133.20 | 104.94 | 23.14 | 6.12 | 40.24 | 43.62 |
| 15 | 133.20 | 15.17 | 32.87 | 6.12 | 40.24 | 43.62 |
| 16 | 133.20 | 15.17 | 32.87 | 6.12 | 40.24 | 43.62 |

Design Ratio

| Member ID | P | M _z | M _y | V _y | V _z | (P,M _z ,M _y) | Worst LC | KL/r | δ | Status |
|-----------|-------|----------------|----------------|----------------|----------------|-------------------------------------|----------|--------------|--------------|--------|
| 1 | 0.060 | 0.561 | 0.000 | 0.036 | 0.000 | 0.591 | #13 | 0.478 | Not Required | Pass |
| 2 | 0.007 | 0.453 | 0.199 | 0.094 | 0.034 | 0.654 | #13 | 0.035 | Not Required | Pass |
| 3 | 0.008 | 0.692 | 0.058 | 0.069 | 0.014 | 0.705 | #13 | 0.045 | Not Required | Pass |
| 4 | 0.008 | 0.689 | 0.216 | 0.069 | 0.043 | 0.760 | #13 | 0.080 | Not Required | Pass |
| 5 | 0.008 | 0.429 | 0.227 | 0.069 | 0.059 | 0.466 | #13 | 0.074 | Not Required | Pass |
| 6 | 0.008 | 0.692 | 0.058 | 0.069 | 0.014 | 0.705 | #13 | 0.045 | Not Required | Pass |
| 7 | 0.008 | 0.429 | 0.227 | 0.069 | 0.059 | 0.466 | #13 | 0.074 | Not Required | Pass |
| 8 | 0.000 | 0.199 | 0.324 | 0.047 | 0.013 | 0.498 | #21 | Not Required | Not Required | Pass |
| 9 | 0.029 | 0.077 | 0.052 | 0.001 | 0.000 | 0.136 | #13 | 0.204 | Not Required | Pass |
| 10 | 0.008 | 0.689 | 0.216 | 0.069 | 0.043 | 0.760 | #13 | 0.080 | Not Required | Pass |
| 11 | 0.000 | 0.199 | 0.324 | 0.047 | 0.013 | 0.498 | #21 | Not Required | Not Required | Pass |
| 12 | 0.007 | 0.453 | 0.199 | 0.094 | 0.034 | 0.654 | #13 | 0.035 | Not Required | Pass |
| 13 | 0.010 | 0.447 | 0.506 | 0.058 | 0.016 | 0.889 | #21 | 0.190 | Not Required | Pass |
| 14 | 0.010 | 0.453 | 0.506 | 0.058 | 0.016 | 0.889 | #21 | 0.190 | Not Required | Pass |
| 15 | 0.000 | 0.199 | 0.324 | 0.047 | 0.013 | 0.498 | #21 | Not Required | Not Required | Pass |
| 16 | 0.000 | 0.199 | 0.324 | 0.047 | 0.013 | 0.498 | #21 | Not Required | Not Required | Pass |

Definitions

| | |
|-------------------------------------|---|
| Φ_t | Safety factor for tensile |
| Φ_c | Safety factor for compression |
| Φ_b | Safety factor for flexure |
| Φ_v | Safety factor for shear |
| E | Modulus of elasticity |
| F _y | Specified minimum yield stress |
| F _u | Specified minimum tensile strength |
| A | Cross-sectional area |
| J | Torsional constant |
| I _{yp} | Moment of inertia about the Y axes |
| I _{zp} | Moment of inertia about the Z axes |
| I _w | Warping constant |
| S _{yp} | Plastic section modulus about the Y axis |
| S _{zp} | Plastic section modulus about the Z axis |
| KL | Effective length |
| C _b | Buckling modification factor (from all load combinations) |
| L _b | Length between braced points |
| LST | Limited slenderness for tension |
| LSC | Limited slenderness for compression |
| LD | Limited deflection |
| P _n | Nominal axial strength (tension/compression) |
| M _n | Nominal flexural strength (about Z/Y axis) |
| V _n | Nominal shear strength (along Z/Y axis) |
| P | Design ratio in case of axial force |
| M _z | Design ratio in case of bending about Z axis |
| M _y | Design ratio in case of bending about Y axis |
| V _y | Design ratio in case of shear along Y axis |
| V _z | Design ratio in case of shear along Z axis |
| (P,M _z ,M _y) | Design ratio in case of axial force and bending action |
| KL/r | Design ratio in case of section slenderness |
| δ | Design ratio in case of member deflection |
| OK | Capacity is provided |

ON
NG

Capacity is provided
Capacity is not provided

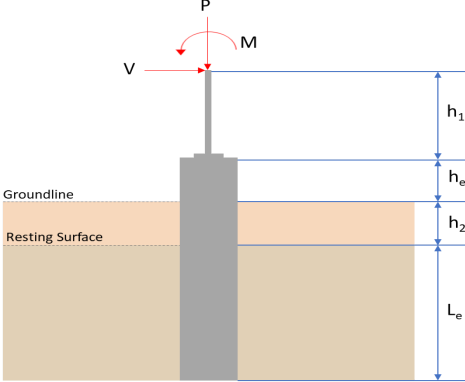
| REFERENCES | CALCULATIONS | RESULTS | | | | | | | | | | | | | | | | | | | | | | | | | | |
|----------------|--|--|---|--|---|---|---|----------|---------|----------------|-----|------|-----------|-------|--------|-------------|--------|--------|-------------|-------|-------|---------------|-------|-------|---------------|--------|--------|--|
| | <p>SkyCiv Foundation Design Pile Foundation</p> <p>Design Information : Design code : IBC 2021 (International Building Code) Unit System : Imperial</p> | | | | | | | | | | | | | | | | | | | | | | | | | | | |
| | <p>Pile Input</p>  <p>Geometry Pile shape: rectangular $b = 48$ in - Pile width $D = 48$ in - Pile depth $L = 6.5$ ft - Total pile length $h_1 = 0$ ft - Lateral load height from the top of the pile, $h_2 = 0$ ft - Depth to resting surface $h_e = 0$ ft - Length of pile above the ground</p> <p>Tabulation of Soil Parameters</p> <table border="1" data-bbox="416 1102 1193 1191"> <thead> <tr> <th>Layer</th> <th>Label</th> <th>Allowable Bearing Pressure (q_a) (psf)</th> <th>Allowable Lateral Pressure (R) (psf/ft)</th> </tr> </thead> <tbody> <tr> <td>1</td> <td>Sand, silty sand, clayey sand, silty gravel & clayey gravel</td> <td>2000.000</td> <td>150.000</td> </tr> </tbody> </table> <p>Tabulation of Loads</p> <table border="1" data-bbox="676 1285 935 1458"> <thead> <tr> <th>Load Component</th> <th>ASD</th> <th>LRFD</th> </tr> </thead> <tbody> <tr> <td>P (kip)</td> <td>7.887</td> <td>11.594</td> </tr> <tr> <td>V_x (kip)</td> <td>-2.424</td> <td>-4.040</td> </tr> <tr> <td>V_z (kip)</td> <td>0.000</td> <td>0.000</td> </tr> <tr> <td>M_x (kipft)</td> <td>0.000</td> <td>0.000</td> </tr> <tr> <td>M_z (kipft)</td> <td>27.621</td> <td>46.711</td> </tr> </tbody> </table> <p>Material Properties $f'_{ck} = 3$ ksi - Concrete strength,</p> | Layer | Label | Allowable Bearing Pressure (q_a) (psf) | Allowable Lateral Pressure (R) (psf/ft) | 1 | Sand, silty sand, clayey sand, silty gravel & clayey gravel | 2000.000 | 150.000 | Load Component | ASD | LRFD | P (kip) | 7.887 | 11.594 | V_x (kip) | -2.424 | -4.040 | V_z (kip) | 0.000 | 0.000 | M_x (kipft) | 0.000 | 0.000 | M_z (kipft) | 27.621 | 46.711 | |
| Layer | Label | Allowable Bearing Pressure (q_a) (psf) | Allowable Lateral Pressure (R) (psf/ft) | | | | | | | | | | | | | | | | | | | | | | | | | |
| 1 | Sand, silty sand, clayey sand, silty gravel & clayey gravel | 2000.000 | 150.000 | | | | | | | | | | | | | | | | | | | | | | | | | |
| Load Component | ASD | LRFD | | | | | | | | | | | | | | | | | | | | | | | | | | |
| P (kip) | 7.887 | 11.594 | | | | | | | | | | | | | | | | | | | | | | | | | | |
| V_x (kip) | -2.424 | -4.040 | | | | | | | | | | | | | | | | | | | | | | | | | | |
| V_z (kip) | 0.000 | 0.000 | | | | | | | | | | | | | | | | | | | | | | | | | | |
| M_x (kipft) | 0.000 | 0.000 | | | | | | | | | | | | | | | | | | | | | | | | | | |
| M_z (kipft) | 27.621 | 46.711 | | | | | | | | | | | | | | | | | | | | | | | | | | |
| | <p>Required depth to resist lateral loads (ASD) H - Point of application of the lateral load</p> $H = h_1 + h_2 + h_e$ $H = (0 \text{ ft}) + (0 \text{ ft}) + (0 \text{ ft})$ $H = 0 \text{ ft}$ <p>Considering x-direction: H_o - Lateral force per length of pile,</p> $H_o = \frac{V_x}{1.57 D}$ $H_o = \frac{(-2.424 \text{ kip})}{1.57 \times (48 \text{ in})}$ $H_o = -0.38599 \text{ kip/ft}$ <p>M_o - Moment per length of pile,</p> $M_o = \frac{M_z + (V_x H)}{1.57 D}$ | | | | | | | | | | | | | | | | | | | | | | | | | | | |

| | | |
|----------|---|---|
| | $M_o = \frac{(27.621 \text{ kipft}) + ((-2.424 \text{ kip}) \times (0 \text{ ft}))}{1.57 \times (48 \text{ in})}$ $M_o = 4.3982 \text{ kipft/ft}$ <p>Required depth of embedment in earth:</p> $L_x^3 - \left(14.14 \times \frac{H_o \times L_x}{R}\right) - \left(18.85 \times \frac{M_o}{R}\right) = 0$ <p>Solving the cubic equation: $L_{e,x} = 5.9763 \text{ ft}$ - Required depth in x-direction,</p> <p>Considering z-direction: $L_{e,z} = 0 \text{ ft}$ - Required depth in z-direction,</p> <p>Minimum embedded depth required: $L_{e,req}$ - Depth of pile required,</p> $L_{e,req} = \text{MAX}[L_{e,x}, L_{e,z}]$ $L_{e,req} = \text{MAX}[(5.9763 \text{ ft}), (0 \text{ ft})]$ $L_{e,req} = 5.976 \text{ ft}$ <p>L_e - Actual embedded length of pile,</p> $L_e = L - h_e - h_2$ $L_e = (6.5 \text{ ft}) - (0 \text{ ft}) - (0 \text{ ft})$ $L_e = 6.5 \text{ ft}$ <p><i>Ratio</i> - Embedded depth</p> $\text{Ratio} = \frac{L_{e,req}}{L_e}$ $\text{Ratio} = \frac{(5.976 \text{ ft})}{(6.5 \text{ ft})}$ $\text{Ratio} = 0.91938$ | <p>Status: PASS Ratio: 0.920</p> |
| | <p>End-bearing Capacity (ASD)</p> <p>A - Pile cross-section area</p> $A = b D$ $A = (48 \text{ in}) \times (48 \text{ in})$ $A = 16 \text{ ft}^2$ <p>q - End-bearing pressure</p> $q = \frac{P_u}{A}$ $q = \frac{(7.887 \text{ kip})}{(16 \text{ ft}^2)}$ $q = 0.49294 \text{ kip/ft}^2$ <p>Check bearing capacity ratio:</p> <p><i>Ratio</i> - Capacity</p> $\text{Ratio} = \frac{q}{q_o}$ $\text{Ratio} = \frac{(0.49294 \text{ kip/ft}^2)}{(2000 \text{ psf})}$ $\text{Ratio} = 0.24647$ | <p>Status: PASS Ratio: 0.250</p> |
| Czerniak | <p>Lateral Soil Pressure (ASD):</p> <p>L/D - Length to least lateral dimension ratio,</p> $L/D = \frac{L}{D}$ $L/D = \frac{(6.5 \text{ ft})}{(48 \text{ in})}$ | |

$$L/D = 1.625$$

Since $L/D \leq 10$,

Pile is short.

Considering x-direction:

$H_o = -0.38599$ kip/ft - Lateral force per length of pile,

$M_o = 4.3982$ kipft/ft - Overturning moment per length of pile,

a - Distance from resting surface to pivot point,

$$a = \frac{(4 M_o L_e) + (3 H_o L_e^2)}{(6 M_o) + (4 H_o L_e)}$$

$$a = \frac{(4 \times (4.3982 \text{ kipft/ft}) \times (6.5 \text{ ft})) + (3 \times (-0.38599 \text{ kip/ft}) \times (6.5 \text{ ft})^2)}{(6 \times (4.3982 \text{ kipft/ft})) + (4 \times (-0.38599 \text{ kip/ft}) \times (6.5 \text{ ft}))}$$

$$a = 4.4826 \text{ ft}$$

p - Earth pressure against the pile at distance $a/2$ from resting surface,

$$p = \frac{0.75 [(4 M_o) + (3 H_o L_e)]^2}{L_e^2 [(3 M_o) + (2 H_o L_e)]}$$

$$p = \frac{0.75 \times [(4 \times (4.3982 \text{ kipft/ft})) + (3 \times (-0.38599 \text{ kip/ft}) \times (6.5 \text{ ft}))]^2}{(6.5 \text{ ft})^2 \times [(3 \times (4.3982 \text{ kipft/ft})) + (2 \times (-0.38599 \text{ kip/ft}) \times (6.5 \text{ ft}))]}$$

$$p = 0.21998 \text{ kip/ft}^2$$

s - Earth pressure against the pile at distance L_e ,

$$s = \frac{6 [(2 M_o) + (H_o L_e)]}{L_e^2}$$

$$s = \frac{6 \times [(2 \times (4.3982 \text{ kipft/ft})) + ((-0.38599 \text{ kip/ft}) \times (6.5 \text{ ft}))]}{(6.5 \text{ ft})^2}$$

$$s = 0.89291 \text{ kip/ft}^2$$

Check lateral soil pressure capacity:

p_a - Allowable lateral soil pressure at depth $a/2$,

$$p_a = R \frac{a}{2}$$

$$p_a = (150 \text{ psf/ft}) \times \frac{(4.4826 \text{ ft})}{2}$$

$$p_a = 0.33619 \text{ kip/ft}^2$$

Ratio - Lateral soil capacity

$$\text{Ratio} = \frac{p}{p_a}$$

$$\text{Ratio} = \frac{(0.21998 \text{ kip/ft}^2)}{(0.33619 \text{ kip/ft}^2)}$$

$$\text{Ratio} = 0.65432$$

p_s - Allowable lateral soil pressure at depth L_e ,

$$p_s = R L_e$$

$$p_s = (150 \text{ psf/ft}) \times (6.5 \text{ ft})$$

$$p_s = 0.975 \text{ kip/ft}^2$$

Ratio - Lateral soil capacity

$$\text{Ratio} = \frac{s}{p_s}$$

$$\text{Ratio} = \frac{(0.89291 \text{ kip/ft}^2)}{(0.975 \text{ kip/ft}^2)}$$

$$\text{Ratio} = 0.91581$$

Status: **PASS**
Ratio: **0.650**

Status: **PASS**
Ratio: **0.920**

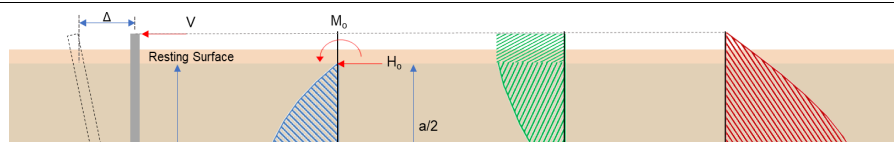



Shear force and Bending moment (x-direction, LRFD)

H_o - Lateral force per length of pile,

$$H_o = \frac{V_x}{1.57 D}$$

$$H_o = \frac{(-4.04 \text{ kip})}{1.57 \times (48 \text{ in})}$$

$$H_o = -0.64331 \text{ kip/ft}$$

M_o - Moment per length of pile,

$$M_o = \frac{M_x + (V_x H)}{1.57 D}$$

$$M_o = \frac{(46.711 \text{ kipft}) + ((-4.04 \text{ kip}) \times (0 \text{ ft}))}{1.57 \times (48 \text{ in})}$$

$$M_o = 7.4381 \text{ kipft/ft}$$

E - Distance from lateral load to resisting surface,

$$E = \frac{M_o}{H_o}$$

$$E = \frac{(7.4381 \text{ kipft/ft})}{(-0.64331 \text{ kip/ft})}$$

$$E = 11.562 \text{ ft}$$

a - Distance from resting surface to pivot point,

$$a = \frac{(4 M_o L_c) + (3 H_o L_c^2)}{(6 M_o) + (4 H_o L_c)}$$

$$a = \frac{(4 \times (7.4381 \text{ kipft/ft}) \times (6.5 \text{ ft})) + (3 \times (-0.64331 \text{ kip/ft}) \times (6.5 \text{ ft})^2)}{(6 \times (7.4381 \text{ kipft/ft})) + (4 \times (-0.64331 \text{ kip/ft}) \times (6.5 \text{ ft}))}$$

$$a = 4.481 \text{ ft}$$

V_{max} - Max shear force located at depth a ,

$$V_{max} = (H_o D) \left[1 - \left[3 \left(\frac{4 E}{L_c} + 3 \right) \left(\frac{a}{L_c} \right)^2 \right] + \left[4 \left(\frac{3 E}{L_c} + 2 \right) \left(\frac{a}{L_c} \right)^3 \right] \right]$$

$$V_{max} = ((-0.64331 \text{ kip/ft}) \times (48 \text{ in})) \times \left[1 - \left[3 \times \left(\frac{4 \times (11.562 \text{ ft})}{(6.5 \text{ ft})} + 3 \right) \times \left(\frac{(4.481 \text{ ft})}{(6.5 \text{ ft})} \right)^2 \right] + \left[4 \times \left(\frac{3 \times (11.562 \text{ ft})}{(6.5 \text{ ft})} + 2 \right) \times \left(\frac{(4.481 \text{ ft})}{(6.5 \text{ ft})} \right)^3 \right] \right]$$

$$V_{max} = 9.797 \text{ kip}$$

M_{max} - Max bending moment located at depth $a/2$,

$$M_{max} = (H_o D L_c) \left[\left(\frac{E}{L_c} + \frac{a}{2 L_c} \right) - \left[\left(\frac{4 E}{L_c} + 3 \right) \left(\frac{a}{2 L_c} \right)^3 \right] + \left[\left(\frac{3 E}{L_c} + 2 \right) \left(\frac{a}{2 L_c} \right)^4 \right] \right]$$

$$M_{max} = ((-0.64331 \text{ kip/ft}) \times (48 \text{ in}) \times (6.5 \text{ ft})) \times \left[\left(\frac{(11.562 \text{ ft})}{(6.5 \text{ ft})} + \frac{(4.481 \text{ ft})}{2 \times (6.5 \text{ ft})} \right) - \left[\left(\frac{4 \times (11.562 \text{ ft})}{(6.5 \text{ ft})} + 3 \right) \times \left(\frac{(4.481 \text{ ft})}{2 \times (6.5 \text{ ft})} \right)^3 \right] + \left[\left(\frac{3 \times (11.562 \text{ ft})}{(6.5 \text{ ft})} + 2 \right) \times \left(\frac{(4.481 \text{ ft})}{2 \times (6.5 \text{ ft})} \right)^4 \right] \right]$$

$$M_{max} = 30.321 \text{ kipft}$$

Minimum Reinforcement Check (LRFD)

Parameters:

$f'_{ck} = 3 \text{ ksi}$ - Concrete strength,
 $f_{yk} = 60 \text{ ksi}$ - Longitudinal reinforcement strength,
 $\phi = 0.65$ - Reduction factor for axial strength,
 $\alpha = 0.8$ - Alpha factor for axial strength,
 $A_g = 2304 \text{ in}^2$ - Gross area of concrete,

Table 22.4.2.1

Longitudinal reinforcement:

Required reinforcement due to axial load, $A_{st,required}$

22.4.2.2, 10.6.1.1

$A_{st,required}$

$$A_{st,required} = \text{Min} \left[\frac{\frac{P}{\phi \alpha} - (0.85 f'_{ck} A_g)}{f_{yk} - (0.85 f'_{ck})}, (0.08 A_g) \right]$$

$$A_{st,required} = \text{Min} \left[\frac{\frac{(11.594 \text{ kip})}{(0.65) \times (0.8)} - (0.85 \times (3 \text{ ksi}) \times (2304 \text{ in}^2))}{(60 \text{ ksi}) - (0.85 \times (3 \text{ ksi}))}, (0.08 \times (2304 \text{ in}^2)) \right]$$

$$A_{st,required} = -101.88 \text{ in}^2$$

A_{min} - Governing minimum reinforcement area,

$$A_{min} = \text{Max} [A_{st,required}, (0.0018 A_g)]$$

$$A_{min} = \text{Max} [(-101.88 \text{ in}^2), (0.0018 \times (2304 \text{ in}^2))]$$

$$A_{min} = 4.1472 \text{ in}^2$$

n_{rebar} - Required number of reinforcement,

$$n_{rebar} = \frac{A_{min}}{A_{rebar}}$$

$$n_{rebar} = \frac{(4.1472 \text{ in}^2)}{(0.3068 \text{ in}^2)}$$

$$n_{rebar} = 14$$

A_{st} - Actual total reinforcement area,

$$A_{st} = n_{rebar} \frac{\pi d_{bar}^2}{4}$$

$$A_{st} = (14) \times \frac{\pi \times (0.625 \text{ in})^2}{4}$$

$$A_{st} = 4.2951 \text{ in}^2$$

Ratio - Capacity

$$\text{Ratio} = \frac{A_{min}}{A_{st}}$$

$$\text{Ratio} = \frac{(4.1472 \text{ in}^2)}{(4.2951 \text{ in}^2)}$$

$$\text{Ratio} = 0.96556$$

Status: **PASS**
Ratio: **0.970**

25.2.3

s_{rebar} - Minimum spacing of reinforcement,

$$s_{rebar} = \text{Max} [1.5, (1.5 d_{bar})]$$

$$s_{rebar} = \text{Max} [1.5, (1.5 \times (0.625 \text{ in}))]$$

$$s_{rebar} = 1.5 \text{ in}$$

Ties:

25.7.2.2 Since longitudinal reinforcement is \leq No. 10: Use #3(0.375 in)

25.7.2.1

s_{ties} - Maximum spacing of ties,

$$s_{ties} = \text{Min} [(16 d_{bar}), (48 d_{ties}), \text{Min} (D, b)]$$

$$s_{ties} = \text{Min} [(16 \times (0.625 \text{ in})), (48 \times (0.375 \text{ in})), \text{Min} ((48 \text{ in}), (48 \text{ in}))]$$

$$s_{ties} = 10 \text{ in}$$

Summary:

Main reinforcement: **14 - #5 (0.625 in)**

Axial Compression Strength (ACI 318-19, LRFD)22.4.2.2 ϕP_N - Allowable axial compressive strength

$$\phi P_N = \phi 0.80 [(0.85 f'_{ck} [A_g - A_{st}]) + (f_{yk} A_{st})]$$

$$\phi P_N = (0.65) \times 0.80 \times [(0.85 \times (3 \text{ ksi}) \times [(2304 \text{ in}^2) - (4.2951 \text{ in}^2)]) + ((60 \text{ ksi}) \times (4.2951 \text{ in}^2))]$$

$$\phi P_N = 3183.4 \text{ kip}$$

Ratio - Capacity

$$\text{Ratio} = \frac{P}{\phi P_N}$$

$$\text{Ratio} = \frac{(11.594 \text{ kip})}{(3183.4 \text{ kip})}$$

$$\text{Ratio} = 0.003642$$

Status: **PASS**
Ratio: **0.000****Shear Strength (ACI 318-19, LRFD)****Parameters:** $b_w = 48 \text{ in}$ - Effective width,22.5.2.2 d - Effective depth

$$d = 0.80 D$$

$$d = 0.80 \times (48 \text{ in})$$

$$d = 38.4 \text{ in}$$

22.5.5.1.3 λ_s - size effect modification factor

$$\lambda_s = \text{MIN} \left[\sqrt{\frac{2}{1 + \frac{d}{10}}}, 1 \right]$$

$$\lambda_s = \text{MIN} \left[\sqrt{\frac{2}{1 + \frac{(38.4 \text{ in})}{10}}}, 1 \right]$$

$$\lambda_s = 0.64282$$

The following variables were converted to be consistent with empirical formula $f'_{ck} = 3 \text{ ksi} \rightarrow 3000 \text{ psi}$,22.5.5.1.1 $V_{c,max}$ - Max shear strength of concrete

$$V_{c,max} = 5 \lambda_s \sqrt{f'_{ck}} b_w d$$

$$V_{c,max} = 5 \times (0.64282) \times \sqrt{(3000 \text{ psi})} \times (48 \text{ in}) \times (38.4 \text{ in})$$

$$V_{c,max} = 324.49 \text{ kip}$$

The following variables were converted to be consistent with empirical formula $f'_{ck} = 3 \text{ ksi} \rightarrow 3000 \text{ psi}$, $P = 11.594 \text{ kip} \rightarrow 11594 \text{ lbf}$,22.5.5.1.1(a) $V_{c,a}$ - Shear strength of concrete (a)

$$V_{c,a} = \left[2 \lambda_s \sqrt{f'_{ck}} + \frac{P}{6 A_g} \right] b_w d$$

$$V_{c,a} = \left[2 \times (0.64282) \times \sqrt{(3000 \text{ psi})} + \frac{(11594 \text{ lbf})}{6 \times (2304 \text{ in}^2)} \right] \times (48 \text{ in}) \times (38.4 \text{ in})$$

$$V_{c,a} = 131.34 \text{ kip}$$

The following variables were converted to be consistent with empirical formula $f'_{ck} = 3 \text{ ksi} \rightarrow 3000 \text{ psi}$,22.5.5.1.2 $V_{c,b}$ - Shear strength of concrete (b)

$$V_{c,b} = \left[2 \lambda_s \sqrt{f'_{ck}} + (0.05 f'_{ck}) \right] b_w d$$

$$V_{c,b} = \left[2 \times (0.64282) \times \sqrt{(3000 \text{ psi})} + (0.05 \times (3000 \text{ psi})) \right] \times (48 \text{ in}) \times (38.4 \text{ in})$$

$$V_{c,b} = 406.27 \text{ kip}$$

 V_c - Governing shear strength of concrete

$$V_c = \text{Min}[V_{c,max}, V_{c,a}, V_{c,b}]$$

$$V_c = \text{Min}[(324.49 \text{ kip}), (131.34 \text{ kip}), (406.27 \text{ kip})]$$

$$V_c = 131.34 \text{ kip}$$

| | | |
|------------------|--|---|
| <p>22.5.1.2</p> | <p>The following variables were converted to be consistent with empirical formula $f'_{ck} = 3 \text{ ksi} \rightarrow 3000 \text{ psi}$.</p> <p>$V_{s,a}$ - Shear strength of steel (a)</p> $V_{s,a} = 8 \sqrt{f'_{ck}} b_w d$ $V_{s,a} = 8 \times \sqrt{(3000 \text{ psi})} \times (48 \text{ in}) \times (38.4 \text{ in})$ $V_{s,a} = 807.65 \text{ kip}$ <p>A_v - Ties rebar area,</p> $A_v = \frac{\pi d_{ties}^2}{4}$ $A_v = \frac{\pi \times (0.375 \text{ in})^2}{4}$ $A_v = 0.11045 \text{ in}^2$ <p>22.5.8.5.3 $V_{s,b}$ - Shear strength of steel (b)</p> $V_{s,b} = \frac{2 A_v f_{ywk} d}{s_{ties}}$ $V_{s,b} = \frac{2 \times (0.11045 \text{ in}^2) \times (60 \text{ ksi}) \times (38.4 \text{ in})}{(10 \text{ in})}$ $V_{s,b} = 50.894 \text{ kip}$ <p>V_s - Governing shear strength of steel</p> $V_s = MIN[V_{s,a}, V_{s,b}]$ $V_s = MIN[(807.65 \text{ kip}), (50.894 \text{ kip})]$ $V_s = 50.894 \text{ kip}$ <p>22.5.1.1 ϕV_n - Allowable shear strength</p> $\phi V_n = \phi (V_c + V_s)$ $\phi V_n = (0.65) \times ((131.34 \text{ kip}) + (50.894 \text{ kip}))$ $\phi V_n = 118.45 \text{ kip}$ <p>Considering x-direction:</p> <p>$V_{max} = 9.797 \text{ kip}$ - Maximum shear force in the x-direction, Ratio - Capacity</p> $Ratio = \frac{V_{max}}{\phi V_n}$ $Ratio = \frac{(9.797 \text{ kip})}{(118.45 \text{ kip})}$ $Ratio = 0.082708$ | <p>Status: PASS Ratio: 0.080</p> |
| <p>14.5.2.1b</p> | <p>Flexural Strength (ACI 318-19, LFRD)</p> <p>S_m - Section modulus</p> $S_m = \frac{b D^2}{6}$ $S_m = \frac{(48 \text{ in}) \times (48 \text{ in})^2}{6}$ $S_m = 18432 \text{ in}^3$ <p>$\lambda = 1$ - Concrete modification factor (Normal concrete), Allowable flexural strength: M_n shall be the lesser of:</p> <p>$\phi M_{n,1}$</p> $\phi M_{n,1} = \phi \times 5 \times \lambda \times \sqrt{f'_c} \times S_m$ $\phi M_{n,1} = 0.65 \times 5 \times 1 \times \sqrt{(3 \text{ ksi})} \times 18432.001 \text{ in}^3$ $\phi M_{n,1} = 273.423 \text{ kipft}$ <p>$\phi M_{n,2}$</p> $\phi M_{n,2} = \phi \times 0.85 \times f'_c \times S_m$ | |

$$\phi M_{n,z} = \phi S_x F_y$$

$$\phi M_{n,z} = (0.65) \times 0.85 \times (3 \text{ ksi}) \times (18432 \text{ in}^3)$$

$$\phi M_{n,z} = 2545.9 \text{ kipft}$$

Therefore,

ϕM_n - Allowable flexural strength,

$$\phi M_n = \text{MIN}[\phi M_{n,1}, \phi M_{n,2}]$$

$$\phi M_n = \text{MIN}[(273.42 \text{ kipft}), (2545.9 \text{ kipft})]$$

$$\phi M_n = 273.42 \text{ kipft}$$

Considering x-direction:

$M_{max} = 30.321 \text{ kipft}$ - Maximum moment in the x-direction,

Ratio - Capacity

$$\text{Ratio} = \frac{M_{max}}{\phi M_n}$$

$$\text{Ratio} = \frac{(30.321 \text{ kipft})}{(273.42 \text{ kipft})}$$

$$\text{Ratio} = 0.11089$$

Status: **PASS**
Ratio: **0.110**