

# Your Project Calculations



Project Name: MTSOLAR\_0682EKH4CH17JA

S3D Model Link:

[https://platform.skyciv.com/structural?preload\\_name=MTSOLAR\\_0682EKH4CH17JA&preload\\_path=Shared%20Enterprise%20Folder/MT\\_Solar\\_Projects/6\\_2023](https://platform.skyciv.com/structural?preload_name=MTSOLAR_0682EKH4CH17JA&preload_path=Shared%20Enterprise%20Folder/MT_Solar_Projects/6_2023)

Public Model Link:

[https://platform.skyciv.com/structural-viewer?project\\_id=X1t2VLeqQGavIG7PveVysEphrH4iQVHP4TPXcUlvnlwNL30EewQ8hfjNr0aQInC](https://platform.skyciv.com/structural-viewer?project_id=X1t2VLeqQGavIG7PveVysEphrH4iQVHP4TPXcUlvnlwNL30EewQ8hfjNr0aQInC)

## Array Specification

|                             |                              |
|-----------------------------|------------------------------|
| Product:                    | Beam                         |
| Unique ID:                  | 1P-0-8TOP-XD-57-L-4Hx3W-5GD2 |
| Duty Classification:        | XD                           |
| Module Width:               | 40.80 in                     |
| Module Length:              | 69.40in                      |
| Number of Rows:             | 4                            |
| Number of Columns:          | 3                            |
| Total Number of Modules:    | 12                           |
| Desired Tilt Angle:         | 35                           |
| Front Edge Clearance:       | 3                            |
| Total Array Height at Tilt: | 10.85 ft                     |
| Total Frame Length:         | 17.00 ft                     |
| Frame Weight:               | 879 lbs                      |
| Array Dimensions N/S:       | 13.77 ft                     |
| Array Dimensions E/W:       | 17.60 ft                     |
| Rail Length:                | 165.20 in                    |
| Rail Spacing:               | 2.89 ft                      |
| Rail Check:                 | Not Checked                  |

## Support Specifications

|                          |                 |
|--------------------------|-----------------|
| Pole Size:               | 8in Pipe Sch 40 |
| Pole Length above Grade: | 6.95 ft         |
| Number of Poles:         | 1               |
| Pole Spacing:            | 0               |

## Foundation Specifications

|                                 |                      |
|---------------------------------|----------------------|
| Foundation Type:                | Square               |
| Foundation Dimensions:          | 48 x 48 in           |
| Foundation Depth (below grade): | Pile 1: 5.75 ft      |
| Foundation Volume:              | 3.407 y <sup>3</sup> |
| Foundation Result:              | PASSED               |
| Mount Twist:                    | 0.000007 kip         |

## Site Info

|                            |                       |
|----------------------------|-----------------------|
| Risk Category:             | I                     |
| Exposure:                  | C                     |
| Soil Classification:       | sand                  |
| Site Location:             | Lyndeborough, NH, USA |
| Wind Speed:                | 105 mph               |
| Snow Load:                 | 80 psf                |
| Design Uplift Pressure:    | Multiple pressures    |
| Design Downforce Pressure: | Multiple pressures    |
| Design Snow Pressure:      | 0.030790 ksf          |



### Design Disclaimer

This software should be used for preliminary designs and should not be used as a final design unless reviewed, verified and designed by a qualified structural engineer.

### AutoDesigner Input

```
{
  "product_type": "Beam",
  "project_id": "MTSOLAR_0682EKH4CH17JA",
  "site_address": "Lyndeborough, NH, USA",
  "module_width": 40.8,
  "module_length": 69.4,
  "number_rows": 4,
  "number_columns": 3,
  "pole_mount_section": "4_40",
  "core_pipe_width": 65,
  "core_pipe_section": "2_40",
  "adjuster_section": "2_40",
  "core_beam_height": 65,
  "core_beam_section": "HSS3x2x1/8",
  "main_pipe_section": "2_12GA",
  "pole_spacing": 15,
  "tilt_angle": 35,
  "ground_clearance": 3,
  "risk_category": "I",
  "exposure_category": "C",
  "frame_duty_override": "auto",
  "pole_override": "auto",
  "soil_type": "sand",
  "foundation_type": "Square",
  "foundation_size": 48,
  "check_rails": false,
  "wind_speed_override": 105,
  "snow_load_override": 80,
  "direct_snow_load": false
}
```

### Design Notes:

- AISC Deflection checks are set to L/1 due to structure design intent
- Foundation Design and Sizing is approximate only

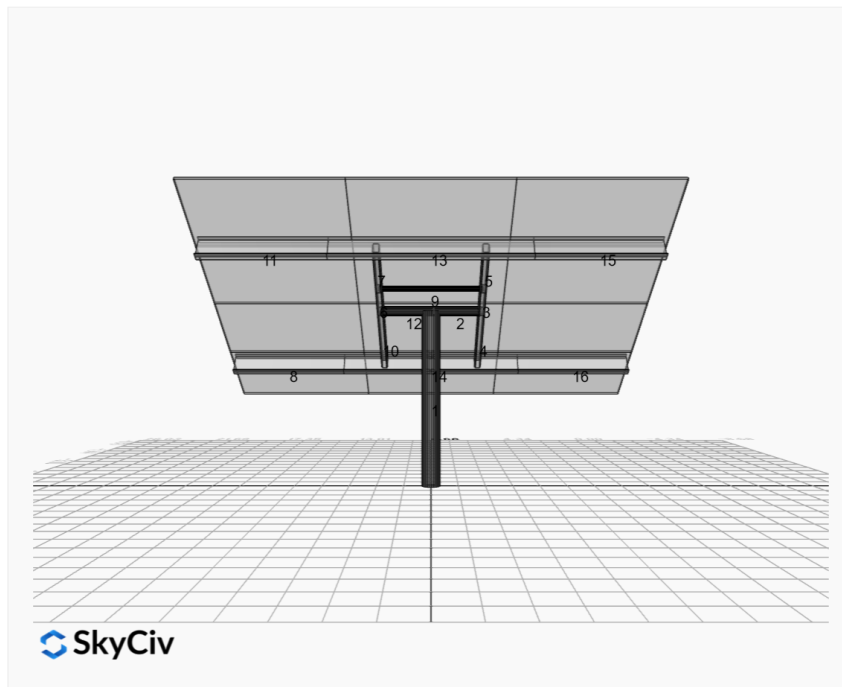

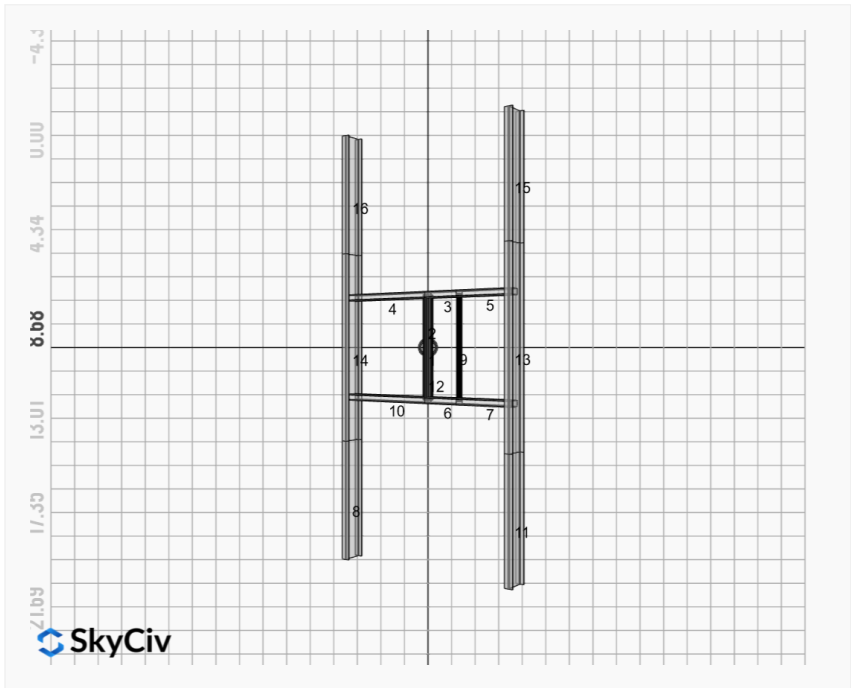
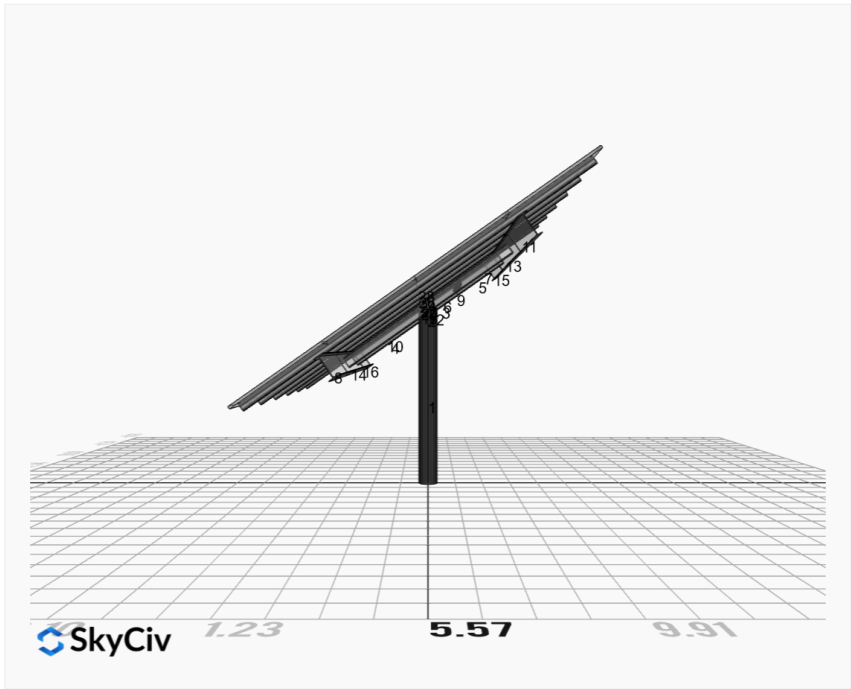

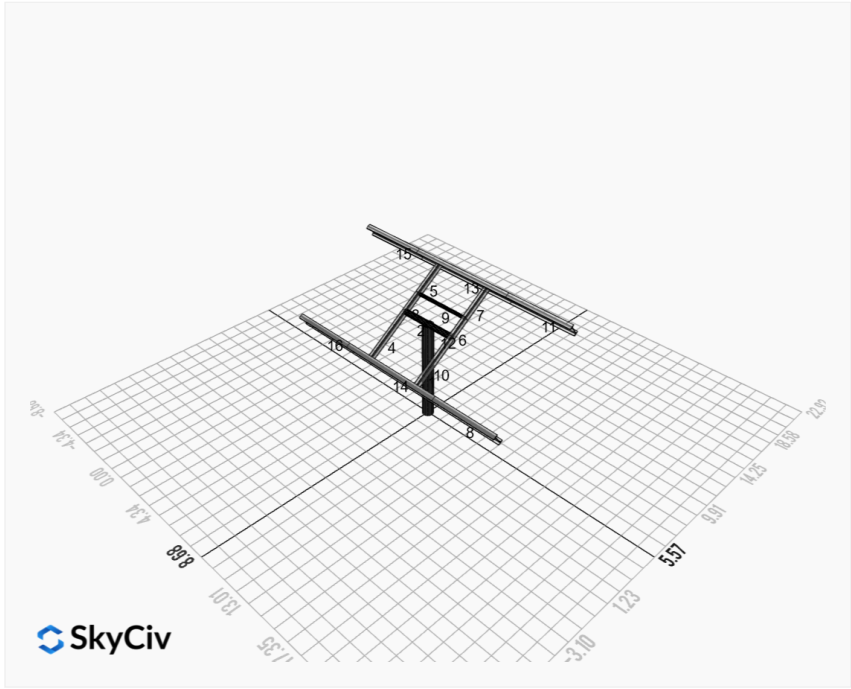

## FEM Results (Envelope Worst Case for each member)

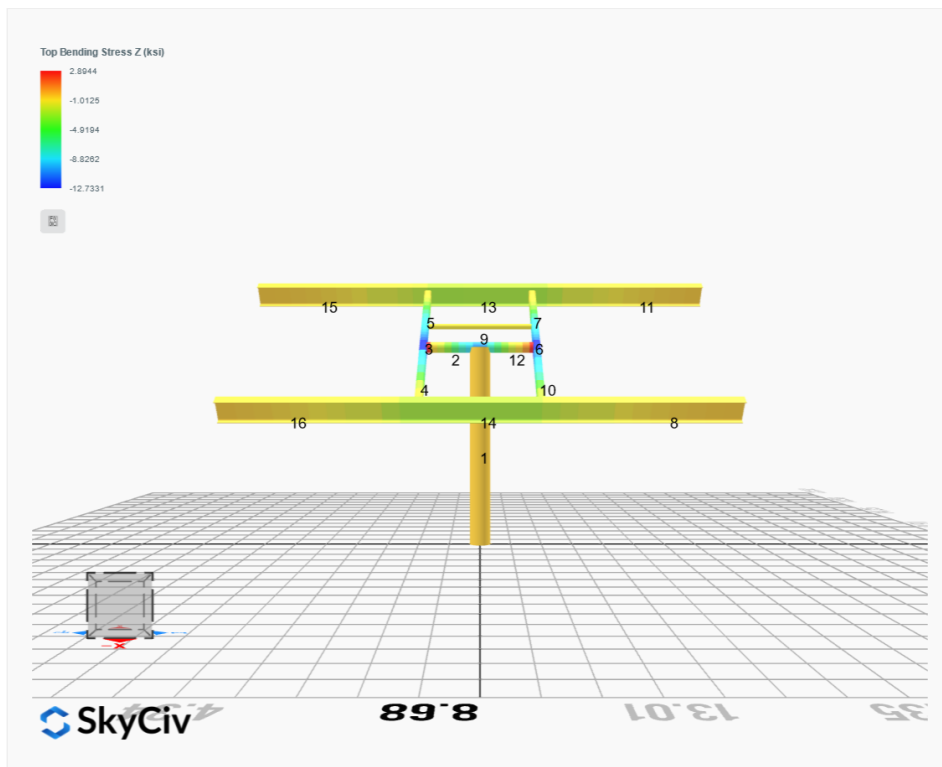
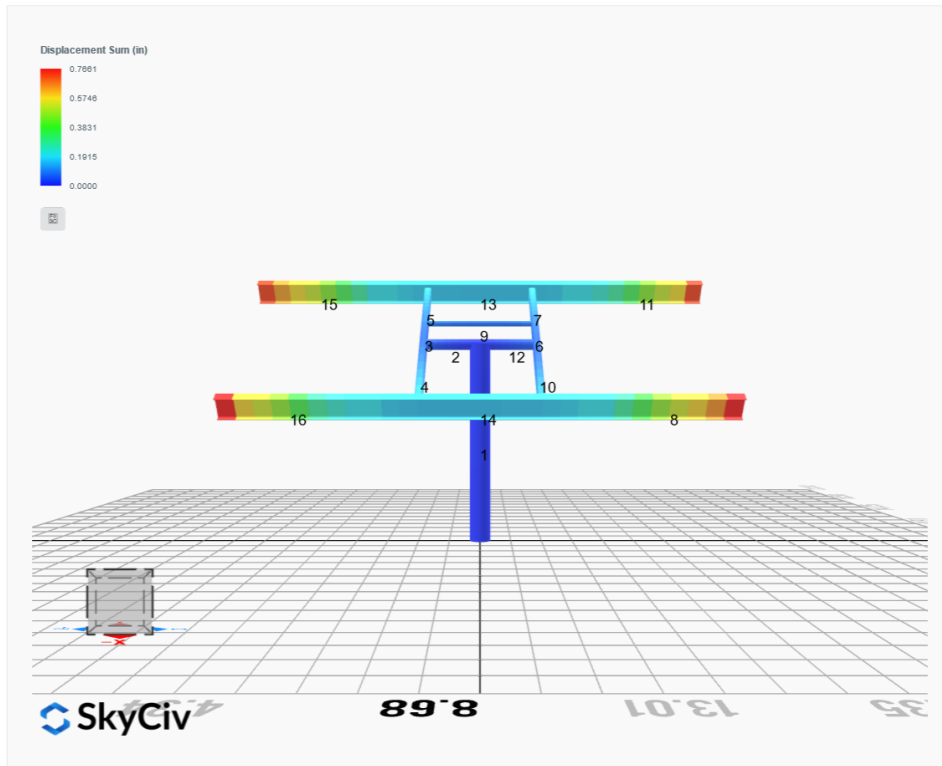

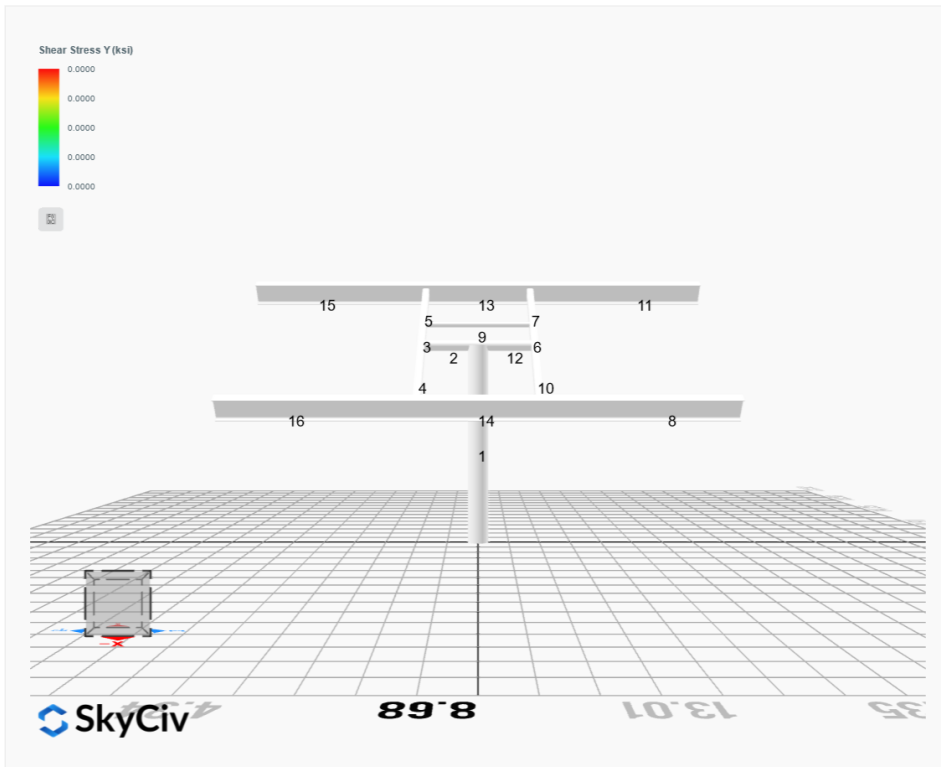
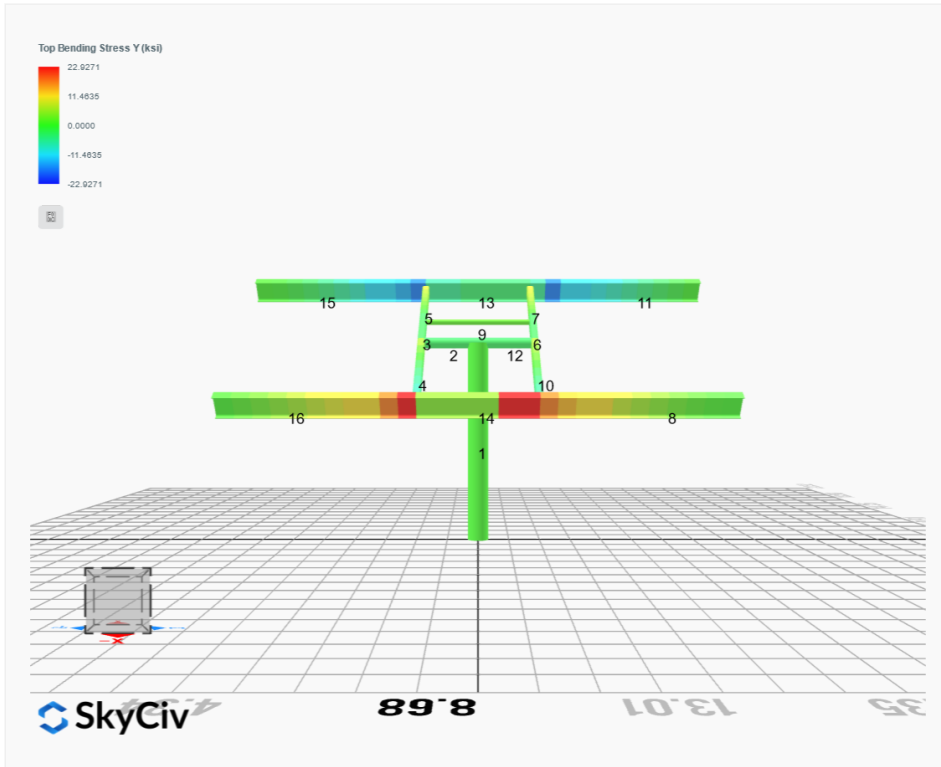

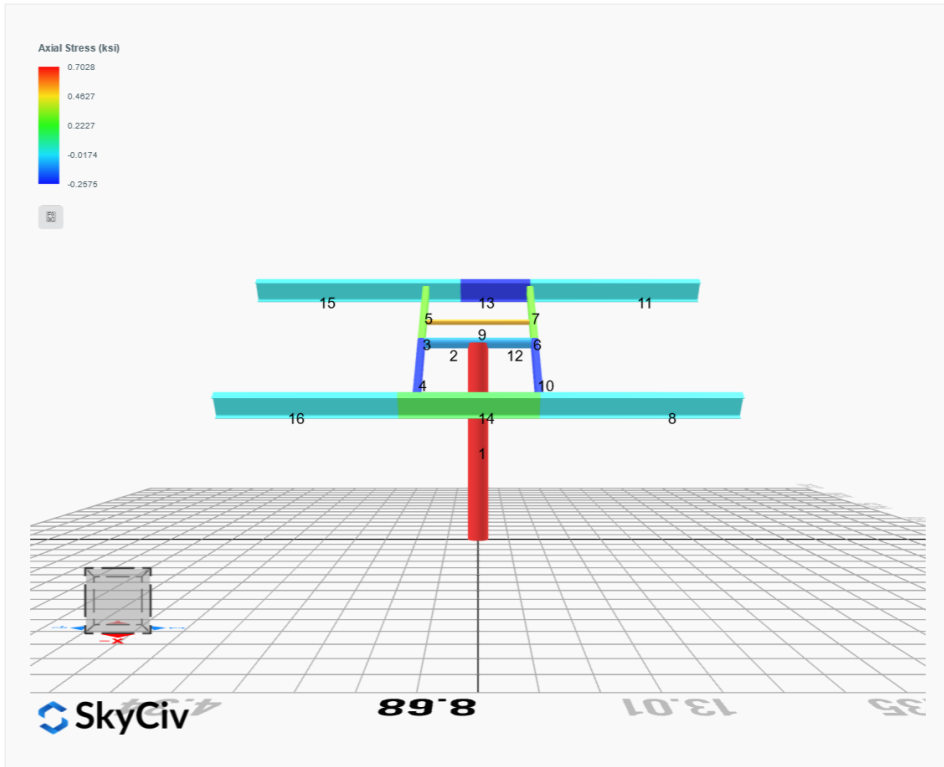

## Reaction Forces for Foundation 1 (Node ID#1), (kip, kip-ft)

### ASD Load Combination Results

| Name  | Fx      | Fy      | Fz      | Mx     | My      | Mz       |
|---|---------|---------|---------|--------|---------|----------|
| ULS: 1. D   | 0.0000  | 2.0280  | -0.0000 | 0.0000 | -0.0000 | 0.0279   |
| ULS: 2. D + L   | 0.0000  | 2.0280  | -0.0000 | 0.0000 | -0.0000 | 0.0279   |
| ULS: 3. D + (S or Lr or R)  | 0.0000  | 7.9306  | 0.0000  | 0.0000 | -0.0000 | 0.0616   |
| ULS: 3. D + (S or Lr or R)  | 0.0000  | 2.0280  | -0.0000 | 0.0000 | -0.0000 | 0.0279   |
| ULS: 4. D + 0.75L + 0.75(S or Lr or R)  | 0.0000  | 6.4550  | 0.0000  | 0.0000 | -0.0000 | 0.0532   |
| ULS: 4. D + 0.75L + 0.75(S or Lr or R)  | 0.0000  | 2.0280  | -0.0000 | 0.0000 | -0.0000 | 0.0279   |
| ULS: 5b. D + 0.7E   | 0.0000  | 2.0280  | -0.0000 | 0.0000 | -0.0000 | 0.0279   |
| ULS: 6b. D + 0.75L + 0.75(0.7)E + 0.75S   | 0.0000  | 6.4550  | 0.0000  | 0.0000 | -0.0000 | 0.0532   |
| ULS: 8. 0.6D + 0.7E   | 0.0000  | 1.2168  | -0.0000 | 0.0000 | -0.0000 | 0.0167   |
| ULS: 5a. D + 0.6W_Wind downforce Case A only                                    | -2.9822 | 6.2870  | -0.0000 | 0.0000 | -0.0000 | 21.2206  |
| ULS: 5a. D + 0.6W_Wind downforce Case B only                                    | -2.9822 | 6.2870  | -0.0000 | 0.0000 | -0.0000 | 21.2206  |
| ULS: 5a. D + 0.6W_Wind uplift Case A only                                       | 2.5162  | -1.5656 | 0.0000  | 0.0000 | -0.0000 | -17.3407 |
| ULS: 5a. D + 0.6W_Wind uplift Case B only                                       | 2.0969  | -0.9667 | -0.0000 | 0.0000 | -0.0000 | -22.9220 |
| ULS: 6a. D + 0.75L + 0.75(0.6)W + 0.75(S or Lr or R)_Wind downforce Case A only | -2.2367 | 9.6493  | -0.0000 | 0.0000 | -0.0000 | 15.9477  |
| ULS: 6a. D + 0.75L + 0.75(0.6)W + 0.75(S or Lr or R)_Wind downforce Case B only | -2.2367 | 9.6493  | -0.0000 | 0.0000 | -0.0000 | 15.9477  |
| ULS: 6a. D + 0.75L + 0.75(0.6)W + 0.75(S or Lr or R)_Wind uplift Case A only    | 1.8872  | 3.7598  | 0.0000  | 0.0000 | -0.0000 | -12.9733 |
| ULS: 6a. D + 0.75L + 0.75(0.6)W + 0.75(S or Lr or R)_Wind uplift Case B only    | 1.5727  | 4.2090  | -0.0000 | 0.0000 | -0.0000 | -17.1592 |
| ULS: 6a. D + 0.75L + 0.75(0.6)W + 0.75(S or Lr or R)_Wind downforce Case A only | -2.2367 | 5.2222  | -0.0000 | 0.0000 | -0.0000 | 15.9224  |
| ULS: 6a. D + 0.75L + 0.75(0.6)W + 0.75(S or Lr or R)_Wind downforce Case B only | -2.2367 | 5.2222  | -0.0000 | 0.0000 | -0.0000 | 15.9224  |
| ULS: 6a. D + 0.75L + 0.75(0.6)W + 0.75(S or Lr or R)_Wind uplift Case A only    | 1.8872  | -0.6672 | 0.0000  | 0.0000 | -0.0000 | -12.9986 |
| ULS: 6a. D + 0.75L + 0.75(0.6)W + 0.75(S or Lr or R)_Wind uplift Case B only    | 1.5727  | -0.2180 | -0.0000 | 0.0000 | -0.0000 | -17.1845 |
| ULS: 7. 0.6D + 0.6W_Wind downforce Case A only                                  | -2.9822 | 5.4758  | -0.0000 | 0.0000 | -0.0000 | 21.2094  |
| ULS: 7. 0.6D + 0.6W_Wind downforce Case B only                                  | -2.9822 | 5.4758  | -0.0000 | 0.0000 | -0.0000 | 21.2094  |
| ULS: 7. 0.6D + 0.6W_Wind uplift Case A only                                     | 2.5162  | -2.3768 | 0.0000  | 0.0000 | -0.0000 | -17.3519 |
| ULS: 7. 0.6D + 0.6W_Wind uplift Case B only                                     | 2.0969  | -1.7779 | -0.0000 | 0.0000 | -0.0000 | -22.9332 |

### Worst Case Reactions LRFD

These calculations are taken directly from the FEA via SkyCiv and are used in the Concrete Checks of the Foundation Module.  
Note: Worst case values are assumed as downforce wind load cases.

| Result           | Value (kip, kip-ft) |
|------------------|---------------------|
| Axial            | 15.4271             |
| Shear X          | -4.9704             |
| Shear Z          | 0.0000              |
| Moment X         | -0.0000             |
| Moment Y (Twist) | 0.0000              |
| Moment Z         | 38.5000             |

### Worst Case Reactions ASD

These results are taken from the worst case values in the above table and are used in the Soil Checks in the Foundation Module.  
Note: Worst case values are assumed as downforce wind load cases.

| Result           | Value (kip, kip-ft) |
|------------------|---------------------|
| Axial            | 9.6493              |
| Shear X          | -2.9822             |
| Shear Z          | -0.0000             |
| Moment X         | 0.0000              |
| Moment Y (Twist) | 0.0000              |
| Moment Z         | 22.9332             |

## Project Details

Design Code: AISC 360-16 LRFD  
 Provision: LRFD  
 Country: United States  
 User Name: sales@mtsolar.us  
 Unit System: imperial



## Design Input Information

| Design Factors |          |          |          |
|----------------|----------|----------|----------|
| $\Phi_t$       | $\Phi_c$ | $\Phi_b$ | $\Phi_v$ |
| 0.9            | 0.9      | 0.9      | 0.9      |

| Design Materials |         |             |             |
|------------------|---------|-------------|-------------|
| ID               | E (ksi) | $F_y$ (ksi) | $F_u$ (ksi) |
| 1                | 29000   | 50          | 65          |

### Section Dimensions

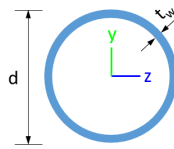

| ID | Name             | d (in) | $t_w$ (in) |  |  |  |  |
|----|------------------|--------|------------|--|--|--|--|
| 3  | 2in Pipe Sch 120 | 2.38   | 0.25       |  |  |  |  |
| 6  | 4in Pipe Sch 120 | 4.50   | 0.44       |  |  |  |  |
| 9  | 8in Pipe Sch 40  | 8.63   | 0.32       |  |  |  |  |

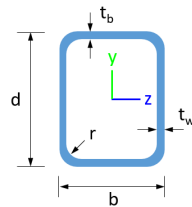

| ID | Name       | d (in) | b (in) | $t_w$ (in) | $t_b$ (in) | r (in) |  |
|----|------------|--------|--------|------------|------------|--------|--|
| 17 | HSS5x3x1/4 | 5.00   | 3.00   | 0.23       | 0.23       | 0.23   |  |



| ID | Name   | d (in) | $t_w$ (in) | $b_t$ (in) | $b_b$ (in) | $t_t$ (in) | $t_b$ (in) | r (in) |
|----|--------|--------|------------|------------|------------|------------|------------|--------|
| 20 | W10x12 | 9.87   | 0.19       | 3.96       | 3.96       | 0.21       | 0.21       | 0.30   |

### Section Properties

| ID | Name             | A (in <sup>2</sup> ) | J (in <sup>4</sup> ) | $I_{yp}$ (in <sup>4</sup> ) | $I_{zp}$ (in <sup>4</sup> ) | $I_w$ (in <sup>6</sup> ) | $S_{yp}$ (in <sup>3</sup> ) | $S_{zp}$ (in <sup>3</sup> ) |
|----|------------------|----------------------|----------------------|-----------------------------|-----------------------------|--------------------------|-----------------------------|-----------------------------|
| 3  | 2in Pipe Sch 120 | 1.67                 | 1.91                 | 0.96                        | 0.96                        | 0.00                     | 1.13                        | 1.13                        |
| 6  | 4in Pipe Sch 120 | 5.58                 | 23.29                | 11.64                       | 11.64                       | 0.00                     | 7.24                        | 7.24                        |
| 9  | 8in Pipe Sch 40  | 8.40                 | 144.98               | 72.49                       | 72.49                       | 0.00                     | 22.21                       | 22.21                       |



|    |        |        |       |       |       |       |
|----|--------|--------|-------|-------|-------|-------|
| 11 | 159.30 | 34.37  | 46.90 | 6.46  | 56.26 | 44.91 |
| 12 | 251.01 | 248.88 | 27.16 | 27.16 | 75.30 | 75.30 |
| 13 | 159.30 | 116.35 | 31.48 | 6.46  | 56.26 | 44.91 |
| 14 | 159.30 | 116.35 | 31.17 | 6.46  | 56.26 | 44.91 |
| 15 | 159.30 | 34.37  | 46.90 | 6.46  | 56.26 | 44.91 |
| 16 | 159.30 | 34.37  | 46.90 | 6.46  | 56.26 | 44.91 |

## Design Ratio

| Member ID | P     | M <sub>z</sub> | M <sub>y</sub> | V <sub>y</sub> | V <sub>z</sub> | (P,M <sub>z</sub> ,M <sub>y</sub> ) | Worst LC | KL/r         | δ            | Status |
|-----------|-------|----------------|----------------|----------------|----------------|-------------------------------------|----------|--------------|--------------|--------|
| 1         | 0.053 | 0.462          | 0.000          | 0.044          | 0.000          | 0.464                               | #32      | 0.298        | Not Required | Pass   |
| 2         | 0.005 | 0.452          | 0.188          | 0.101          | 0.033          | 0.596                               | #21      | 0.036        | Not Required | Pass   |
| 3         | 0.011 | 0.644          | 0.055          | 0.064          | 0.001          | 0.704                               | #21      | 0.046        | Not Required | Pass   |
| 4         | 0.011 | 0.632          | 0.224          | 0.063          | 0.047          | 0.776                               | #21      | 0.082        | Not Required | Pass   |
| 5         | 0.011 | 0.399          | 0.231          | 0.064          | 0.060          | 0.462                               | #21      | 0.076        | Not Required | Pass   |
| 6         | 0.011 | 0.644          | 0.055          | 0.064          | 0.001          | 0.704                               | #21      | 0.046        | Not Required | Pass   |
| 7         | 0.011 | 0.399          | 0.231          | 0.064          | 0.060          | 0.462                               | #21      | 0.076        | Not Required | Pass   |
| 8         | 0.000 | 0.096          | 0.333          | 0.034          | 0.020          | 0.429                               | #21      | Not Required | Not Required | Pass   |
| 9         | 0.026 | 0.052          | 0.052          | 0.001          | 0.000          | 0.116                               | #21      | 0.206        | Not Required | Pass   |
| 10        | 0.011 | 0.632          | 0.224          | 0.063          | 0.047          | 0.776                               | #21      | 0.082        | Not Required | Pass   |
| 11        | 0.000 | 0.097          | 0.333          | 0.034          | 0.020          | 0.430                               | #21      | Not Required | Not Required | Pass   |
| 12        | 0.005 | 0.452          | 0.188          | 0.101          | 0.033          | 0.596                               | #21      | 0.036        | Not Required | Pass   |
| 13        | 0.011 | 0.288          | 0.624          | 0.046          | 0.028          | 0.894                               | #21      | 0.204        | Not Required | Pass   |
| 14        | 0.012 | 0.289          | 0.624          | 0.046          | 0.028          | 0.892                               | #21      | 0.204        | Not Required | Pass   |
| 15        | 0.000 | 0.097          | 0.333          | 0.034          | 0.020          | 0.430                               | #21      | Not Required | Not Required | Pass   |
| 16        | 0.000 | 0.096          | 0.333          | 0.034          | 0.020          | 0.429                               | #21      | Not Required | Not Required | Pass   |

## Definitions

|                                     |   |
|-------------------------------------|---|
| $\Phi_t$                            | Safety factor for tensile                                 |
| $\Phi_c$                            | Safety factor for compression                             |
| $\Phi_b$                            | Safety factor for flexure                                 |
| $\Phi_v$                            | Safety factor for shear                                   |
| E                                   | Modulus of elasticity                                     |
| F <sub>y</sub>                      | Specified minimum yield stress                            |
| F <sub>u</sub>                      | Specified minimum tensile strength                        |
| A                                   | Cross-sectional area                                      |
| J                                   | Torsional constant  |
| I <sub>yp</sub>                     | Moment of inertia about the Y axes                        |
| I <sub>zp</sub>                     | Moment of inertia about the Z axes                        |
| I <sub>w</sub>                      | Warping constant  |
| S <sub>yp</sub>                     | Plastic section modulus about the Y axis                  |
| S <sub>zp</sub>                     | Plastic section modulus about the Z axis                  |
| KL                                  | Effective length  |
| C <sub>b</sub>                      | Buckling modification factor (from all load combinations) |
| L <sub>b</sub>                      | Length between braced points                              |
| LST                                 | Limited slenderness for tension                           |
| LSC                                 | Limited slenderness for compression                       |
| LD                                  | Limited deflection  |
| P <sub>n</sub>                      | Nominal axial strength (tension/compression)              |
| M <sub>n</sub>                      | Nominal flexural strength (about Z/Y axis)                |
| V <sub>n</sub>                      | Nominal shear strength (along Z/Y axis)                   |
| P                                   | Design ratio in case of axial force                       |
| M <sub>z</sub>                      | Design ratio in case of bending about Z axis              |
| M <sub>y</sub>                      | Design ratio in case of bending about Y axis              |
| V <sub>y</sub>                      | Design ratio in case of shear along Y axis                |
| V <sub>z</sub>                      | Design ratio in case of shear along Z axis                |
| (P,M <sub>z</sub> ,M <sub>y</sub> ) | Design ratio in case of axial force and bending action    |
| KL/r                                | Design ratio in case of section slenderness               |
| δ                                   | Design ratio in case of member deflection                 |
| OK                                  | Capacity is provided                                      |
| NG                                  | Capacity is not provided                                  |

Capacity is not provided

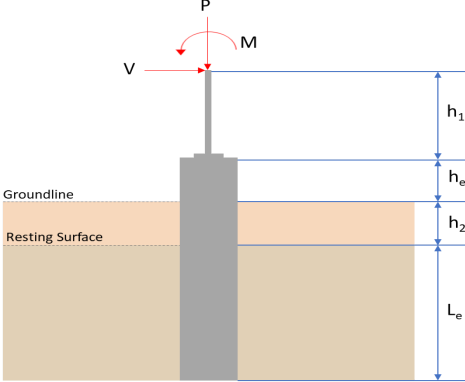
| REFERENCES     | CALCULATIONS  | RESULTS                                    |   |  |   |   |   |          |         |                |     |      |           |       |        |             |        |        |             |       |       |               |       |       |               |        |        |  |
|----------------|---|--|---|--|---|---|---|----------|---------|----------------|-----|------|-----------|-------|--------|-------------|--------|--------|-------------|-------|-------|---------------|-------|-------|---------------|--------|--------|--|
|                | <p><b>SkyCiv Foundation Design</b><br/>Pile Foundation</p> <p><b>Design Information :</b><br/>Design code : IBC 2021 (International Building Code)<br/>Unit System : Imperial</p>   |  |   |  |   |   |   |          |         |                |     |      |           |       |        |             |        |        |             |       |       |               |       |       |               |        |        |  |
|                | <p><b>Pile Input</b></p>  <p><b>Geometry</b><br/>Pile shape: rectangular<br/><math>b = 48</math> in - Pile width<br/><math>D = 48</math> in - Pile depth<br/><math>L = 5.75</math> ft - Total pile length<br/><math>h_1 = 0</math> ft - Lateral load height from the top of the pile,<br/><math>h_2 = 0</math> ft - Depth to resting surface<br/><math>h_e = 0</math> ft - Length of pile above the ground</p> <p><b>Tabulation of Soil Parameters</b></p> <table border="1" data-bbox="416 1102 1193 1191"> <thead> <tr> <th>Layer</th> <th>Label</th> <th>Allowable Bearing Pressure (<math>q_a</math>) (psf)</th> <th>Allowable Lateral Pressure (<math>R</math>) (psf/ft)</th> </tr> </thead> <tbody> <tr> <td>1</td> <td>Sand, silty sand, clayey sand, silty gravel &amp; clayey gravel</td> <td>2000.000</td> <td>150.000</td> </tr> </tbody> </table> <p><b>Tabulation of Loads</b></p> <table border="1" data-bbox="676 1288 935 1458"> <thead> <tr> <th>Load Component</th> <th>ASD</th> <th>LRFD</th> </tr> </thead> <tbody> <tr> <td><math>P</math> (kip)</td> <td>9.649</td> <td>15.427</td> </tr> <tr> <td><math>V_x</math> (kip)</td> <td>-2.982</td> <td>-4.970</td> </tr> <tr> <td><math>V_z</math> (kip)</td> <td>0.000</td> <td>0.000</td> </tr> <tr> <td><math>M_x</math> (kipft)</td> <td>0.000</td> <td>0.000</td> </tr> <tr> <td><math>M_z</math> (kipft)</td> <td>22.933</td> <td>38.500</td> </tr> </tbody> </table> <p><b>Material Properties</b><br/><math>f'_{ck} = 3</math> ksi - Concrete strength,</p> | Layer                                      | Label                                       | Allowable Bearing Pressure ( $q_a$ ) (psf) | Allowable Lateral Pressure ( $R$ ) (psf/ft) | 1 | Sand, silty sand, clayey sand, silty gravel & clayey gravel | 2000.000 | 150.000 | Load Component | ASD | LRFD | $P$ (kip) | 9.649 | 15.427 | $V_x$ (kip) | -2.982 | -4.970 | $V_z$ (kip) | 0.000 | 0.000 | $M_x$ (kipft) | 0.000 | 0.000 | $M_z$ (kipft) | 22.933 | 38.500 |  |
| Layer          | Label   | Allowable Bearing Pressure ( $q_a$ ) (psf) | Allowable Lateral Pressure ( $R$ ) (psf/ft) |  |   |   |   |          |         |                |     |      |           |       |        |             |        |        |             |       |       |               |       |       |               |        |        |  |
| 1              | Sand, silty sand, clayey sand, silty gravel & clayey gravel   | 2000.000                                   | 150.000                                     |  |   |   |   |          |         |                |     |      |           |       |        |             |        |        |             |       |       |               |       |       |               |        |        |  |
| Load Component | ASD   | LRFD                                       |   |  |   |   |   |          |         |                |     |      |           |       |        |             |        |        |             |       |       |               |       |       |               |        |        |  |
| $P$ (kip)      | 9.649   | 15.427                                     |   |  |   |   |   |          |         |                |     |      |           |       |        |             |        |        |             |       |       |               |       |       |               |        |        |  |
| $V_x$ (kip)    | -2.982  | -4.970                                     |   |  |   |   |   |          |         |                |     |      |           |       |        |             |        |        |             |       |       |               |       |       |               |        |        |  |
| $V_z$ (kip)    | 0.000   | 0.000                                      |   |  |   |   |   |          |         |                |     |      |           |       |        |             |        |        |             |       |       |               |       |       |               |        |        |  |
| $M_x$ (kipft)  | 0.000   | 0.000                                      |   |  |   |   |   |          |         |                |     |      |           |       |        |             |        |        |             |       |       |               |       |       |               |        |        |  |
| $M_z$ (kipft)  | 22.933  | 38.500                                     |   |  |   |   |   |          |         |                |     |      |           |       |        |             |        |        |             |       |       |               |       |       |               |        |        |  |
|                | <p><b>Required depth to resist lateral loads (ASD)</b><br/><math>H</math> - Point of application of the lateral load</p> $H = h_1 + h_2 + h_e$ $H = (0 \text{ ft}) + (0 \text{ ft}) + (0 \text{ ft})$ $H = 0 \text{ ft}$ <p><b>Considering x-direction:</b><br/><math>H_o</math> - Lateral force per length of pile,</p> $H_o = \frac{V_x}{1.57 D}$ $H_o = \frac{(-2.982 \text{ kip})}{1.57 \times (48 \text{ in})}$ $H_o = -0.47484 \text{ kip/ft}$ <p><math>M_o</math> - Moment per length of pile,</p> $M_o = \frac{M_z + (V_x H)}{1.57 D}$  |  |   |  |   |   |   |          |         |                |     |      |           |       |        |             |        |        |             |       |       |               |       |       |               |        |        |  |

$$M_o = \frac{(22.933 \text{ kipft}) + ((-2.982 \text{ kip}) \times (0 \text{ ft}))}{1.57 \times (48 \text{ in})}$$

$$M_o = 3.6518 \text{ kipft/ft}$$

Required depth of embedment in earth:

$$L_x^3 - \left(14.14 \times \frac{H_o \times L_x}{R}\right) - \left(18.85 \times \frac{M_o}{R}\right) = 0$$

Solving the cubic equation:

$$L_{e,x} = 5.2307 \text{ ft} - \text{Required depth in x-direction,}$$

**Considering z-direction:**

$$L_{e,z} = 0 \text{ ft} - \text{Required depth in z-direction,}$$

**Minimum embedded depth required:**

$L_{e,req}$  - Depth of pile required,

$$L_{e,req} = \text{MAX}[L_{e,x}, L_{e,z}]$$

$$L_{e,req} = \text{MAX}[(5.2307 \text{ ft}), (0 \text{ ft})]$$

$$L_{e,req} = 5.231 \text{ ft}$$

$L_e$  - Actual embedded length of pile,

$$L_e = L - h_e - h_2$$

$$L_e = (5.75 \text{ ft}) - (0 \text{ ft}) - (0 \text{ ft})$$

$$L_e = 5.75 \text{ ft}$$

**Ratio** - Embedded depth

$$\text{Ratio} = \frac{L_{e,req}}{L_e}$$

$$\text{Ratio} = \frac{(5.231 \text{ ft})}{(5.75 \text{ ft})}$$

$$\text{Ratio} = 0.90974$$

Status: **PASS**  
Ratio: **0.910**

### End-bearing Capacity (ASD)

A - Pile cross-section area

$$A = b D$$

$$A = (48 \text{ in}) \times (48 \text{ in})$$

$$A = 16 \text{ ft}^2$$

q - End-bearing pressure

$$q = \frac{P_v}{A}$$

$$q = \frac{(9.649 \text{ kip})}{(16 \text{ ft}^2)}$$

$$q = 0.60306 \text{ kip/ft}^2$$

**Check bearing capacity ratio:**

**Ratio** - Capacity

$$\text{Ratio} = \frac{q}{q_o}$$

$$\text{Ratio} = \frac{(0.60306 \text{ kip/ft}^2)}{(2000 \text{ psf})}$$

$$\text{Ratio} = 0.30153$$

Status: **PASS**  
Ratio: **0.300**

Czerniak

### Lateral Soil Pressure (ASD):

L/D - Length to least lateral dimension ratio,

$$L/D = \frac{L}{D}$$

$$L/D = \frac{(5.75 \text{ ft})}{(48 \text{ in})}$$

$$L/D = 1.4375$$

Since  $L/D \leq 10$ ,

Pile is short.

**Considering x-direction:**

$H_o = -0.47484$  kip/ft - Lateral force per length of pile,

$M_o = 3.6518$  kipft/ft - Overturning moment per length of pile,

$a$  - Distance from resting surface to pivot point,

$$a = \frac{(4 M_o L_e) + (3 H_o L_e^2)}{(6 M_o) + (4 H_o L_e)}$$

$$a = \frac{(4 \times (3.6518 \text{ kipft/ft}) \times (5.75 \text{ ft})) + (3 \times (-0.47484 \text{ kip/ft}) \times (5.75 \text{ ft})^2)}{(6 \times (3.6518 \text{ kipft/ft})) + (4 \times (-0.47484 \text{ kip/ft}) \times (5.75 \text{ ft}))}$$

$$a = 3.9927 \text{ ft}$$

$p$  - Earth pressure against the pile at distance  $a/2$  from resting surface,

$$p = \frac{0.75 [(4 M_o) + (3 H_o L_e)]^2}{L_e^2 [(3 M_o) + (2 H_o L_e)]}$$

$$p = \frac{0.75 \times [(4 \times (3.6518 \text{ kipft/ft})) + (3 \times (-0.47484 \text{ kip/ft}) \times (5.75 \text{ ft}))]^2}{(5.75 \text{ ft})^2 \times [(3 \times (3.6518 \text{ kipft/ft})) + (2 \times (-0.47484 \text{ kip/ft}) \times (5.75 \text{ ft}))]}$$

$$p = 0.16995 \text{ kip/ft}^2$$

$s$  - Earth pressure against the pile at distance  $L_e$ ,

$$s = \frac{6 [(2 M_o) + (H_o L_e)]}{L_e^2}$$

$$s = \frac{6 \times [(2 \times (3.6518 \text{ kipft/ft})) + ((-0.47484 \text{ kip/ft}) \times (5.75 \text{ ft}))]}{(5.75 \text{ ft})^2}$$

$$s = 0.82991 \text{ kip/ft}^2$$

**Check lateral soil pressure capacity:**

$p_a$  - Allowable lateral soil pressure at depth  $a/2$ ,

$$p_a = R \frac{a}{2}$$

$$p_a = (150 \text{ psf/ft}) \times \frac{(3.9927 \text{ ft})}{2}$$

$$p_a = 0.29945 \text{ kip/ft}^2$$

*Ratio* - Lateral soil capacity

$$\text{Ratio} = \frac{p}{p_a}$$

$$\text{Ratio} = \frac{(0.16995 \text{ kip/ft}^2)}{(0.29945 \text{ kip/ft}^2)}$$

$$\text{Ratio} = 0.56753$$

$p_s$  - Allowable lateral soil pressure at depth  $L_e$ ,

$$p_s = R L_e$$

$$p_s = (150 \text{ psf/ft}) \times (5.75 \text{ ft})$$

$$p_s = 0.8625 \text{ kip/ft}^2$$

*Ratio* - Lateral soil capacity

$$\text{Ratio} = \frac{s}{p_s}$$

$$\text{Ratio} = \frac{(0.82991 \text{ kip/ft}^2)}{(0.8625 \text{ kip/ft}^2)}$$

$$\text{Ratio} = 0.96222$$

Status: **PASS**  
Ratio: **0.570**

Status: **PASS**  
Ratio: **0.960**

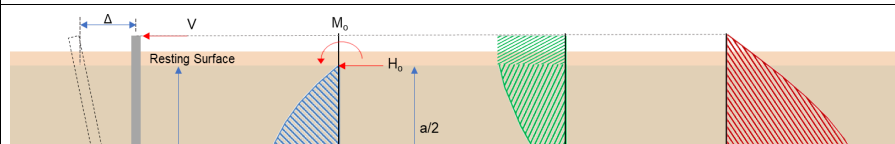

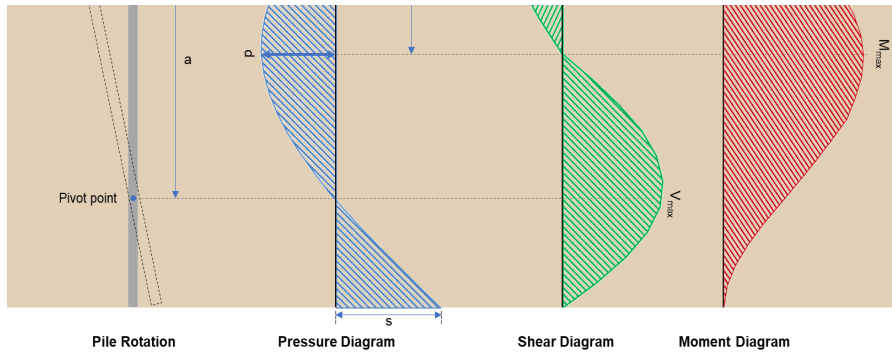

### Shear force and Bending moment (x-direction, LRFD)

$H_o$  - Lateral force per length of pile,

$$H_o = \frac{V_x}{1.57 D}$$

$$H_o = \frac{(-4.97 \text{ kip})}{1.57 \times (48 \text{ in})}$$

$$H_o = -0.7914 \text{ kip/ft}$$

$M_o$  - Moment per length of pile,

$$M_o = \frac{M_x + (V_x H)}{1.57 D}$$

$$M_o = \frac{(38.5 \text{ kipft}) + ((-4.97 \text{ kip}) \times (0 \text{ ft}))}{1.57 \times (48 \text{ in})}$$

$$M_o = 6.1306 \text{ kipft/ft}$$

$E$  - Distance from lateral load to resisting surface,

$$E = \frac{M_o}{H_o}$$

$$E = \frac{(6.1306 \text{ kipft/ft})}{(-0.7914 \text{ kip/ft})}$$

$$E = 7.7465 \text{ ft}$$

$a$  - Distance from resting surface to pivot point,

$$a = \frac{(4 M_o L_c) + (3 H_o L_c^2)}{(6 M_o) + (4 H_o L_c)}$$

$$a = \frac{(4 \times (6.1306 \text{ kipft/ft}) \times (5.75 \text{ ft})) + (3 \times (-0.7914 \text{ kip/ft}) \times (5.75 \text{ ft})^2)}{(6 \times (6.1306 \text{ kipft/ft})) + (4 \times (-0.7914 \text{ kip/ft}) \times (5.75 \text{ ft}))}$$

$$a = 3.992 \text{ ft}$$

$V_{max}$  - Max shear force located at depth  $a$ ,

$$V_{max} = (H_o D) \left[ 1 - \left[ 3 \left( \frac{4 E}{L_c} + 3 \right) \left( \frac{a}{L_c} \right)^2 \right] + \left[ 4 \left( \frac{3 E}{L_c} + 2 \right) \left( \frac{a}{L_c} \right)^3 \right] \right]$$

$$V_{max} = ((-0.7914 \text{ kip/ft}) \times (48 \text{ in})) \times \left[ 1 - \left[ 3 \times \left( \frac{4 \times (7.7465 \text{ ft})}{(5.75 \text{ ft})} + 3 \right) \times \left( \frac{(3.992 \text{ ft})}{(5.75 \text{ ft})} \right)^2 \right] + \left[ 4 \times \left( \frac{3 \times (7.7465 \text{ ft})}{(5.75 \text{ ft})} + 2 \right) \times \left( \frac{(3.992 \text{ ft})}{(5.75 \text{ ft})} \right)^3 \right] \right]$$

$$V_{max} = 9.634 \text{ kip}$$

$M_{max}$  - Max bending moment located at depth  $a/2$ ,

$$M_{max} = (H_o D L_c) \left[ \left( \frac{E}{L_c} + \frac{a}{2 L_c} \right) - \left[ \left( \frac{4 E}{L_c} + 3 \right) \left( \frac{a}{2 L_c} \right)^3 \right] + \left[ \left( \frac{3 E}{L_c} + 2 \right) \left( \frac{a}{2 L_c} \right)^4 \right] \right]$$

$$M_{max} = ((-0.7914 \text{ kip/ft}) \times (48 \text{ in}) \times (5.75 \text{ ft})) \times \left[ \left( \frac{(7.7465 \text{ ft})}{(5.75 \text{ ft})} + \frac{(3.992 \text{ ft})}{2 \times (5.75 \text{ ft})} \right) - \left[ \left( \frac{4 \times (7.7465 \text{ ft})}{(5.75 \text{ ft})} + 3 \right) \times \left( \frac{(3.992 \text{ ft})}{2 \times (5.75 \text{ ft})} \right)^3 \right] + \left[ \left( \frac{3 \times (7.7465 \text{ ft})}{(5.75 \text{ ft})} + 2 \right) \times \left( \frac{(3.992 \text{ ft})}{2 \times (5.75 \text{ ft})} \right)^4 \right] \right]$$

$$M_{max} = 26.051 \text{ kipft}$$

### Minimum Reinforcement Check (LRFD)

#### Parameters:

$f'_{ck} = 3 \text{ ksi}$  - Concrete strength,  
 $f_{yk} = 60 \text{ ksi}$  - Longitudinal reinforcement strength,  
 $\phi = 0.65$  - Reduction factor for axial strength,  
 $\alpha = 0.8$  - Alpha factor for axial strength,  
 $A_g = 2304 \text{ in}^2$  - Gross area of concrete,

Table 22.4.2.1

#### Longitudinal reinforcement:

Required reinforcement due to axial load,  $A_{st,required}$

22.4.2.2, 10.6.1.1

$A_{st,required}$

$$A_{st,required} = \text{Min} \left[ \frac{\frac{P}{\phi \alpha} - (0.85 f'_{ck} A_g)}{f_{yk} - (0.85 f'_{ck})}, (0.08 A_g) \right]$$

$$A_{st,required} = \text{Min} \left[ \frac{\frac{(15.427 \text{ kip})}{(0.65) \times (0.8)} - (0.85 \times (3 \text{ ksi}) \times (2304 \text{ in}^2))}{(60 \text{ ksi}) - (0.85 \times (3 \text{ ksi}))}, (0.08 \times (2304 \text{ in}^2)) \right]$$

$$A_{st,required} = -101.75 \text{ in}^2$$

$A_{min}$  - Governing minimum reinforcement area,

$$A_{min} = \text{Max} [A_{st,required}, (0.0018 A_g)]$$

$$A_{min} = \text{Max} [(-101.75 \text{ in}^2), (0.0018 \times (2304 \text{ in}^2))]$$

$$A_{min} = 4.1472 \text{ in}^2$$

$n_{rebar}$  - Required number of reinforcement,

$$n_{rebar} = \frac{A_{min}}{A_{rebar}}$$

$$n_{rebar} = \frac{(4.1472 \text{ in}^2)}{(0.3068 \text{ in}^2)}$$

$$n_{rebar} = 14$$

$A_{st}$  - Actual total reinforcement area,

$$A_{st} = n_{rebar} \frac{\pi d_{bar}^2}{4}$$

$$A_{st} = (14) \times \frac{\pi \times (0.625 \text{ in})^2}{4}$$

$$A_{st} = 4.2951 \text{ in}^2$$

Ratio - Capacity

$$\text{Ratio} = \frac{A_{min}}{A_{st}}$$

$$\text{Ratio} = \frac{(4.1472 \text{ in}^2)}{(4.2951 \text{ in}^2)}$$

$$\text{Ratio} = 0.96556$$

Status: **PASS**  
Ratio: **0.970**

25.2.3

$s_{rebar}$  - Minimum spacing of reinforcement,

$$s_{rebar} = \text{Max} [1.5, (1.5 d_{bar})]$$

$$s_{rebar} = \text{Max} [1.5, (1.5 \times (0.625 \text{ in}))]$$

$$s_{rebar} = 1.5 \text{ in}$$

#### Ties:

25.7.2.2 Since longitudinal reinforcement is  $\leq$  No. 10: Use #3(0.375 in)

25.7.2.1

$s_{ties}$  - Maximum spacing of ties,

$$s_{ties} = \text{Min} [(16 d_{bar}), (48 d_{ties}), \text{Min} (D, b)]$$

$$s_{ties} = \text{Min} [(16 \times (0.625 \text{ in})), (48 \times (0.375 \text{ in})), \text{Min} ((48 \text{ in}), (48 \text{ in}))]$$

$$s_{ties} = 10 \text{ in}$$

#### Summary:

Main reinforcement: **14 - #5 (0.625 in)**

**Axial Compression Strength (ACI 318-19, LRFD)**22.4.2.2  $\phi P_N$  - Allowable axial compressive strength

$$\phi P_N = \phi 0.80 [(0.85 f'_{ck} [A_g - A_{st}] + (f_{yt} A_{st}))]$$

$$\phi P_N = (0.65) \times 0.80 \times [(0.85 \times (3 \text{ ksi}) \times [(2304 \text{ in}^2) - (4.2951 \text{ in}^2)]) + ((60 \text{ ksi}) \times (4.2951 \text{ in}^2))]$$

$$\phi P_N = 3183.4 \text{ kip}$$

Ratio - Capacity

$$\text{Ratio} = \frac{P}{\phi P_N}$$

$$\text{Ratio} = \frac{(15.427 \text{ kip})}{(3183.4 \text{ kip})}$$

$$\text{Ratio} = 0.0048461$$

Status: **PASS**  
Ratio: **0.000****Shear Strength (ACI 318-19, LRFD)****Parameters:** $b_w = 48 \text{ in}$  - Effective width,22.5.2.2  $d$  - Effective depth

$$d = 0.80 D$$

$$d = 0.80 \times (48 \text{ in})$$

$$d = 38.4 \text{ in}$$

22.5.5.1.3  $\lambda_s$  - size effect modification factor

$$\lambda_s = \text{MIN} \left[ \sqrt{\frac{2}{1 + \frac{d}{10}}}, 1 \right]$$

$$\lambda_s = \text{MIN} \left[ \sqrt{\frac{2}{1 + \frac{(38.4 \text{ in})}{10}}}, 1 \right]$$

$$\lambda_s = 0.64282$$

The following variables were converted to be consistent with empirical formula  $f'_{ck} = 3 \text{ ksi} \rightarrow 3000 \text{ psi}$ ,22.5.5.1.1  $V_{c,max}$  - Max shear strength of concrete

$$V_{c,max} = 5 \lambda_s \sqrt{f'_{ck}} b_w d$$

$$V_{c,max} = 5 \times (0.64282) \times \sqrt{(3000 \text{ psi})} \times (48 \text{ in}) \times (38.4 \text{ in})$$

$$V_{c,max} = 324.49 \text{ kip}$$

The following variables were converted to be consistent with empirical formula  $f'_{ck} = 3 \text{ ksi} \rightarrow 3000 \text{ psi}$ ,  $P = 15.427 \text{ kip} \rightarrow 15427 \text{ lbf}$ ,22.5.5.1.1(a)  $V_{c,a}$  - Shear strength of concrete (a)

$$V_{c,a} = \left[ 2 \lambda_s \sqrt{f'_{ck}} + \frac{P}{6 A_g} \right] b_w d$$

$$V_{c,a} = \left[ 2 \times (0.64282) \times \sqrt{(3000 \text{ psi})} + \frac{(15427 \text{ lbf})}{6 \times (2304 \text{ in}^2)} \right] \times (48 \text{ in}) \times (38.4 \text{ in})$$

$$V_{c,a} = 131.85 \text{ kip}$$

The following variables were converted to be consistent with empirical formula  $f'_{ck} = 3 \text{ ksi} \rightarrow 3000 \text{ psi}$ ,22.5.5.1.2  $V_{c,b}$  - Shear strength of concrete (b)

$$V_{c,b} = \left[ 2 \lambda_s \sqrt{f'_{ck}} + (0.05 f'_{ck}) \right] b_w d$$

$$V_{c,b} = \left[ 2 \times (0.64282) \times \sqrt{(3000 \text{ psi})} + (0.05 \times (3000 \text{ psi})) \right] \times (48 \text{ in}) \times (38.4 \text{ in})$$

$$V_{c,b} = 406.27 \text{ kip}$$

 $V_c$  - Governing shear strength of concrete

$$V_c = \text{Min}[V_{c,max}, V_{c,a}, V_{c,b}]$$

$$V_c = \text{Min}[(324.49 \text{ kip}), (131.85 \text{ kip}), (406.27 \text{ kip})]$$

$$V_c = 131.85 \text{ kip}$$

|                  |   |   |
|------------------|---|---|
| <p>22.5.1.2</p>  | <p>The following variables were converted to be consistent with empirical formula <math>f'_{ck} = 3 \text{ ksi} \rightarrow 3000 \text{ psi}</math>.</p> <p><math>V_{s,a}</math> - Shear strength of steel (a)</p> $V_{s,a} = 8 \sqrt{f'_{ck}} b_w d$ $V_{s,a} = 8 \times \sqrt{(3000 \text{ psi})} \times (48 \text{ in}) \times (38.4 \text{ in})$ $V_{s,a} = 807.65 \text{ kip}$ <p><math>A_v</math> - Ties rebar area,</p> $A_v = \frac{\pi d_{ties}^2}{4}$ $A_v = \frac{\pi \times (0.375 \text{ in})^2}{4}$ $A_v = 0.11045 \text{ in}^2$ <p>22.5.8.5.3 <math>V_{s,b}</math> - Shear strength of steel (b)</p> $V_{s,b} = \frac{2 A_v f_{ywk} d}{s_{ties}}$ $V_{s,b} = \frac{2 \times (0.11045 \text{ in}^2) \times (60 \text{ ksi}) \times (38.4 \text{ in})}{(10 \text{ in})}$ $V_{s,b} = 50.894 \text{ kip}$ <p><math>V_s</math> - Governing shear strength of steel</p> $V_s = \text{MIN}[V_{s,a}, V_{s,b}]$ $V_s = \text{MIN}[(807.65 \text{ kip}), (50.894 \text{ kip})]$ $V_s = 50.894 \text{ kip}$ <p>22.5.1.1 <math>\phi V_n</math> - Allowable shear strength</p> $\phi V_n = \phi (V_c + V_s)$ $\phi V_n = (0.65) \times ((131.85 \text{ kip}) + (50.894 \text{ kip}))$ $\phi V_n = 118.78 \text{ kip}$ <p><b>Considering x-direction:</b></p> <p><math>V_{max} = 9.634 \text{ kip}</math> - Maximum shear force in the x-direction,<br/> <b>Ratio</b> - Capacity</p> $\text{Ratio} = \frac{V_{max}}{\phi V_n}$ $\text{Ratio} = \frac{(9.634 \text{ kip})}{(118.78 \text{ kip})}$ $\text{Ratio} = 0.081105$ | <p>Status: <b>PASS</b><br/> Ratio: <b>0.080</b></p> |
| <p>14.5.2.1b</p> | <p><b>Flexural Strength (ACI 318-19, LRFD)</b></p> <p><math>S_m</math> - Section modulus</p> $S_m = \frac{b D^2}{6}$ $S_m = \frac{(48 \text{ in}) \times (48 \text{ in})^2}{6}$ $S_m = 18432 \text{ in}^3$ <p><math>\lambda = 1</math> - Concrete modification factor (Normal concrete),<br/> Allowable flexural strength:<br/> <math>M_n</math> shall be the lesser of:</p> <p><math>\phi M_{n,1}</math></p> $\phi M_{n,1} = \phi \times 5 \times \lambda \times \sqrt{f'_c} \times S_m$ $\phi M_{n,1} = 0.65 \times 5 \times 1 \times \sqrt{(3 \text{ ksi})} \times 18432.001 \text{ in}^3$ $\phi M_{n,1} = 273.423 \text{ kipft}$ <p><math>\phi M_{n,2}</math></p> $\phi M_{n,2} = 0.85 f'_c S_m$  |   |

$$\phi M_{n,z} = \phi S_{xx} F_{ck} \leq m$$

$$\phi M_{n,z} = (0.65) \times 0.85 \times (3 \text{ ksi}) \times (18432 \text{ in}^3)$$

$$\phi M_{n,z} = 2545.9 \text{ kipft}$$

Therefore,

$\phi M_n$  - Allowable flexural strength,

$$\phi M_n = \text{MIN}[\phi M_{n,1}, \phi M_{n,2}]$$

$$\phi M_n = \text{MIN}[(273.42 \text{ kipft}), (2545.9 \text{ kipft})]$$

$$\phi M_n = 273.42 \text{ kipft}$$

**Considering x-direction:**

$M_{max} = 26.051 \text{ kipft}$  - Maximum moment in the x-direction,

*Ratio* - Capacity

$$\text{Ratio} = \frac{M_{max}}{\phi M_n}$$

$$\text{Ratio} = \frac{(26.051 \text{ kipft})}{(273.42 \text{ kipft})}$$

$$\text{Ratio} = 0.095276$$

Status: **PASS**  
Ratio: **0.100**