

Project Name: MTSOLAR_3JJH9A34K8378 **Date:** Wed Jun 11 2025
Location: Jackson, WY 83001, USA **Number of Modules:** 12
Unique ID: 1P-0-6TOP-HD-84-L-3Hx4W-1BI0 **Number of Poles:** 1
Dealer: _____ **Date Sold:** _____

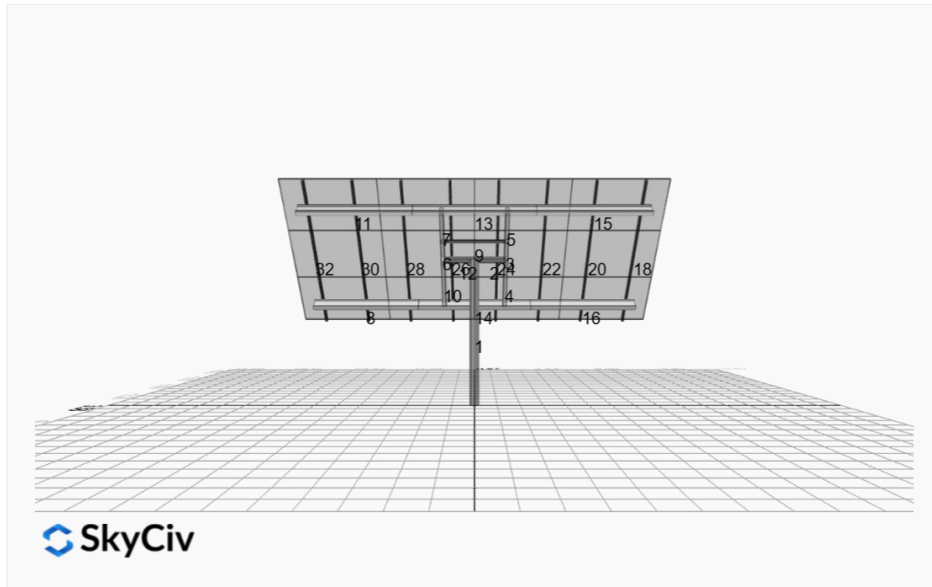

Array Dimensions N/S	11.13 ft
Array Dimensions E/W	23.33 ft
Winter Tilt Angle	50
Front Edge Clearance	5 ft

MT Solar Bill of Materials (1P-0-6TOP-HD-84-L-3Hx4W-1BI0)

Part	Short Description	BOM Qty
MTS-PC-6	6IN Pole Cap Assembly	1
MTS-HF-HD	H-Frame Assembly-HD	1
MTS-HD-Wing-84	84IN HD Wing	4
MTS-CLAMP-HOOK-4PK	Hook Clamp	4

Rail Bill of Materials

Part	Qty
Rails (134in)	8
Rail Attachment	16
Module Mid Clamp	16
Module End Clamp	16
Ground Lug	4

Site Details:

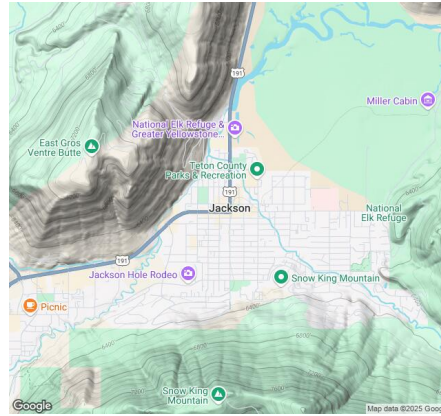

Site Address: Jackson, WY 83001, USA

Array Specification

Duty Classification:	HD
Module Width:	44.00 in
Module Length:	69.00in
Number of Rows:	3
Number of Columns:	4
Total Number of Modules:	12
Winter Tilt Angle:	50
Front Edge Clearance:	5
Total Array Height at Tilt:	13.52 ft
Total Frame Length:	21.50 ft
Module Info/Notes:	
Array Dimensions N/S:	11.13 ft
Array Dimensions E/W:	23.33 ft
Rail Length:	133.50 in
Rail Spacing:	2.92 ft

Support Specifications

Pole Size:	6in Pipe Sch 40
Pole Length above Grade:	9.26 ft
Number of Poles:	1
Pole Spacing:	0

Foundation Specifications

Foundation Type:	Round
Foundation Dimensions:	Ø36 in
Foundation Depth (below grade):	Pile 1: 8.00 ft
Foundation Volume:	2.094 y ³

Site Info

Risk Category:	I
Exposure:	C
Soil Classification:	sand
Site Location:	Jackson, WY 83001, USA
Wind Speed:	90 mph
Snow Load:	75 psf

Design Disclaimer

This software should be used for preliminary designs and should not be used as a final design unless reviewed, verified and designed by a qualified structural engineer.

AutoDesigner Input

```
{ "product_type": "Beam", "designer_name": "", "designer_email": "lkames@energy-1.net", "designer_phone": "", "project_id": "MTSOLAR_3JJH9A34K8378", "site_address": "Jackson, WY 83001, USA", "module_info": "", "module_width": 44, "module_length": 69, "number_rows": 3, "number_columns": 4, "pole_mount_section": "4_40", "core_pipe_width": 65, "core_pipe_section": "2_40", "adjuster_section": "2_40", "core_beam_height": 65, "core_beam_section": "HSS3x2x1/8", "main_pipe_section": "2_12GA", "pole_spacing": 15, "tilt_angle": 50, "ground_clearance": 5, "risk_category": "I", "exposure_category": "C", "frame_duty_override": "auto", "pole_override": "auto", "soil_type": "sand", "customer_foundation_override": "36_Round", "foundation_type": "Round", "foundation_size": 36, "check_rails": false, "wind_speed_override": 90, "snow_load_override": 75, "direct_snow_load": false, "add_angle_brace": false }
```

Design Notes:

- AISC Deflection checks are set to L/1 due to structure design intent
- Foundation Soil Parameters used in this Autodesign are all estimates, proper geotechnical reports are required to confirm soil profiles
- Wind speeds, snow loads and other site specific results are based on ASCE 7 2016
- Steel frame design checks are based on AISC 360 2016 (LRFD)
- Foundation Design and Sizing is approximate only

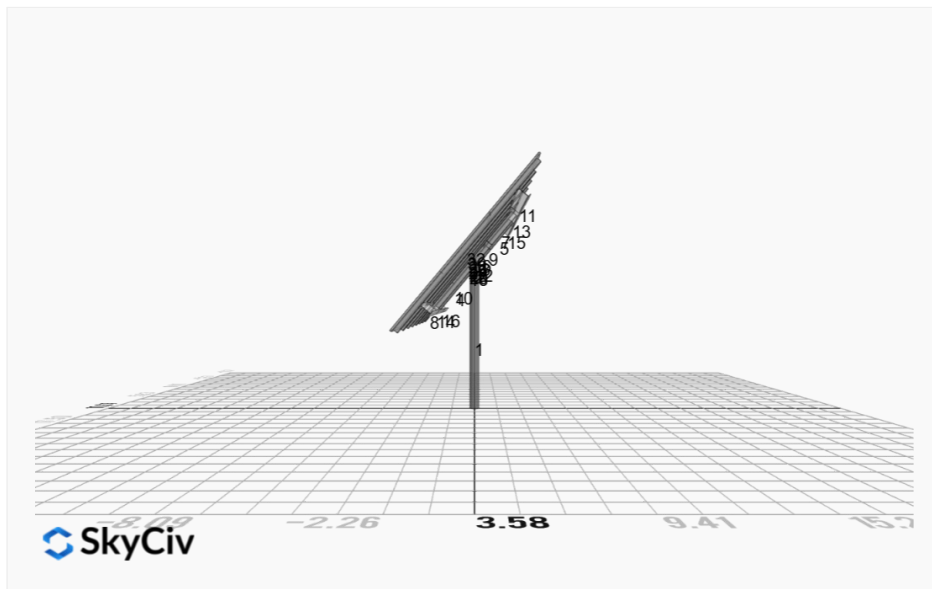
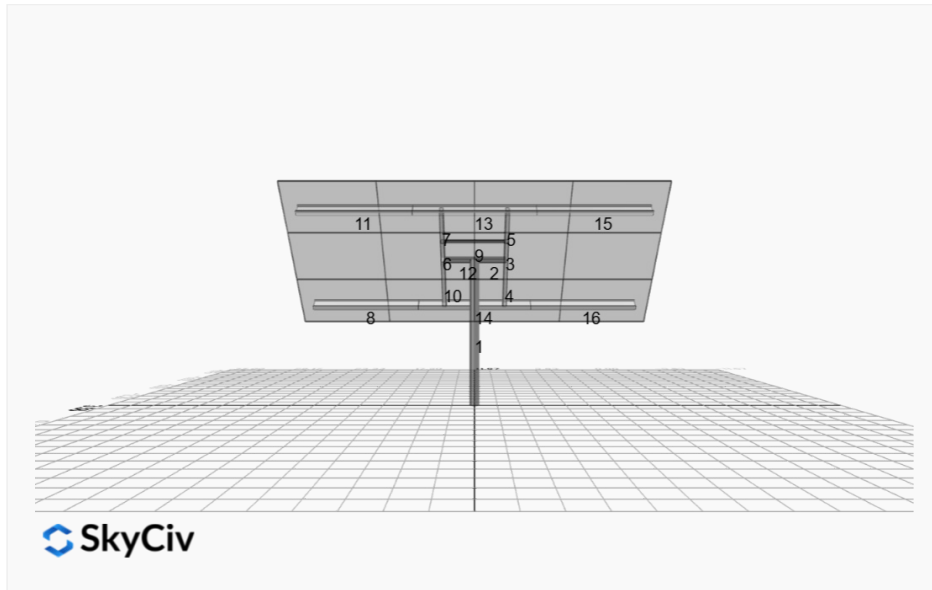

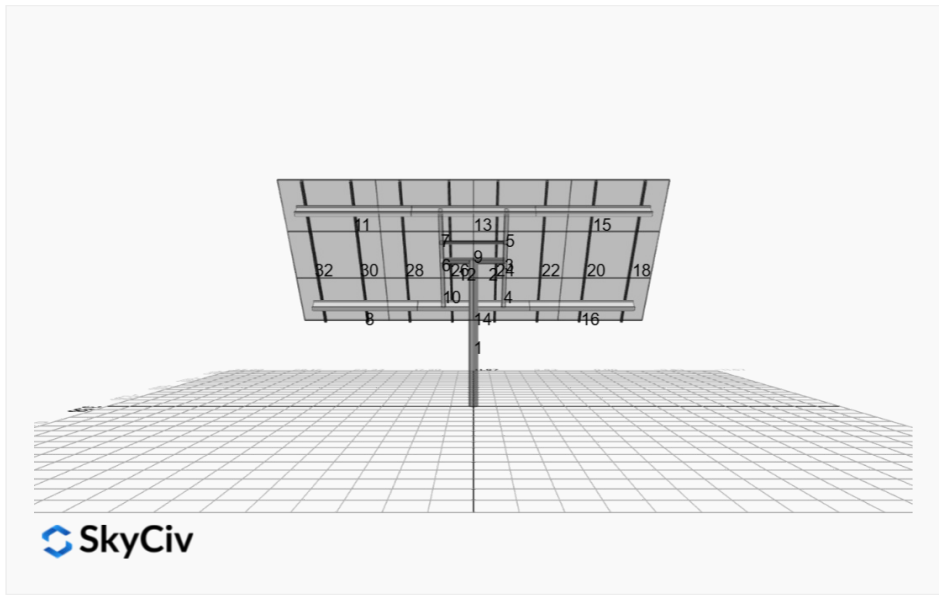
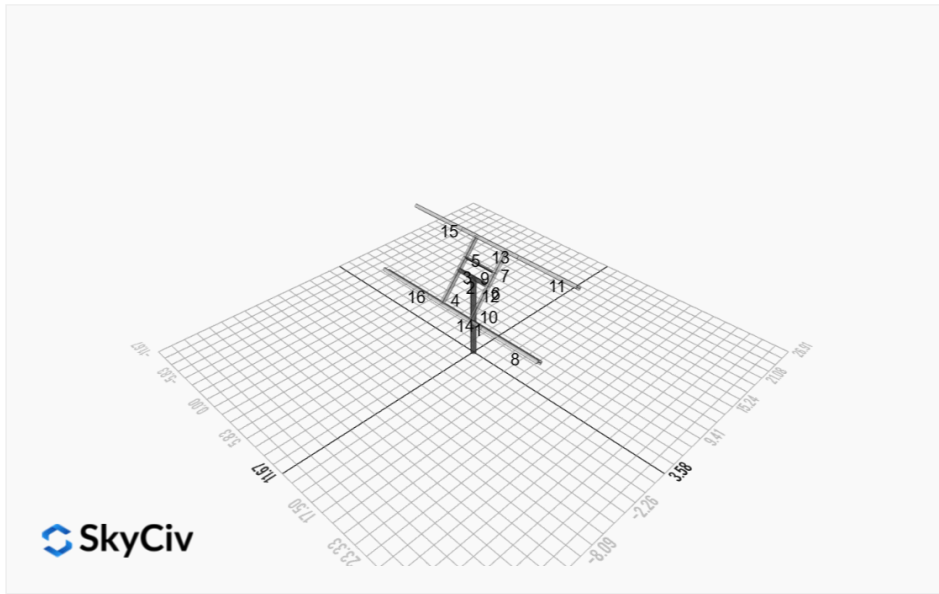
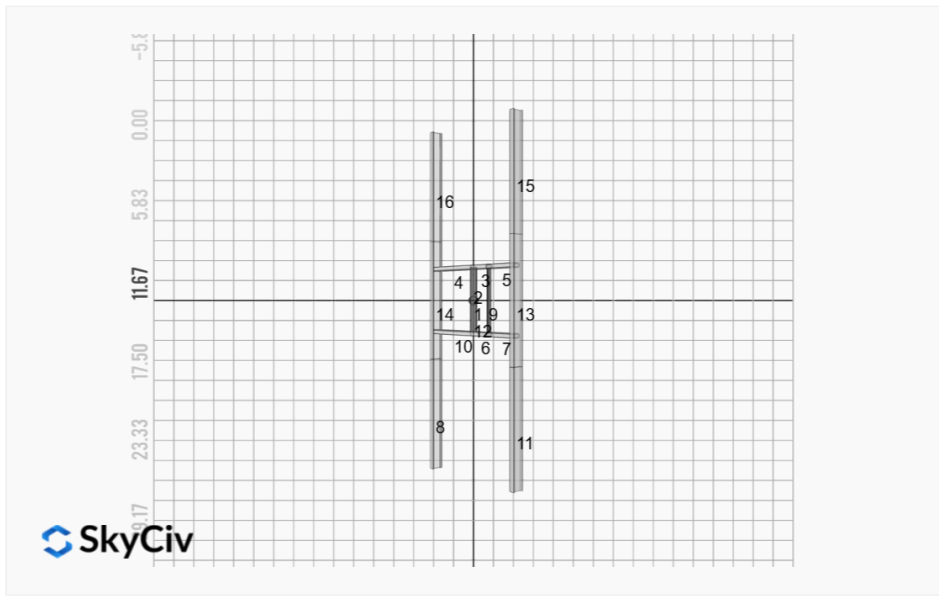

FEM Results (Envelope Worst Case for each member)

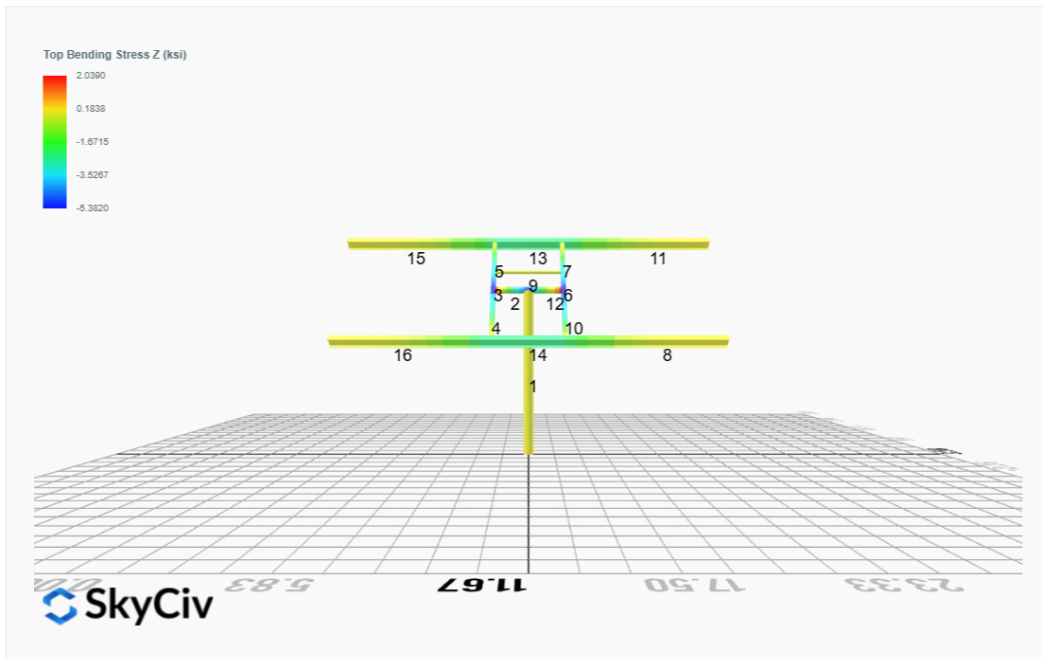
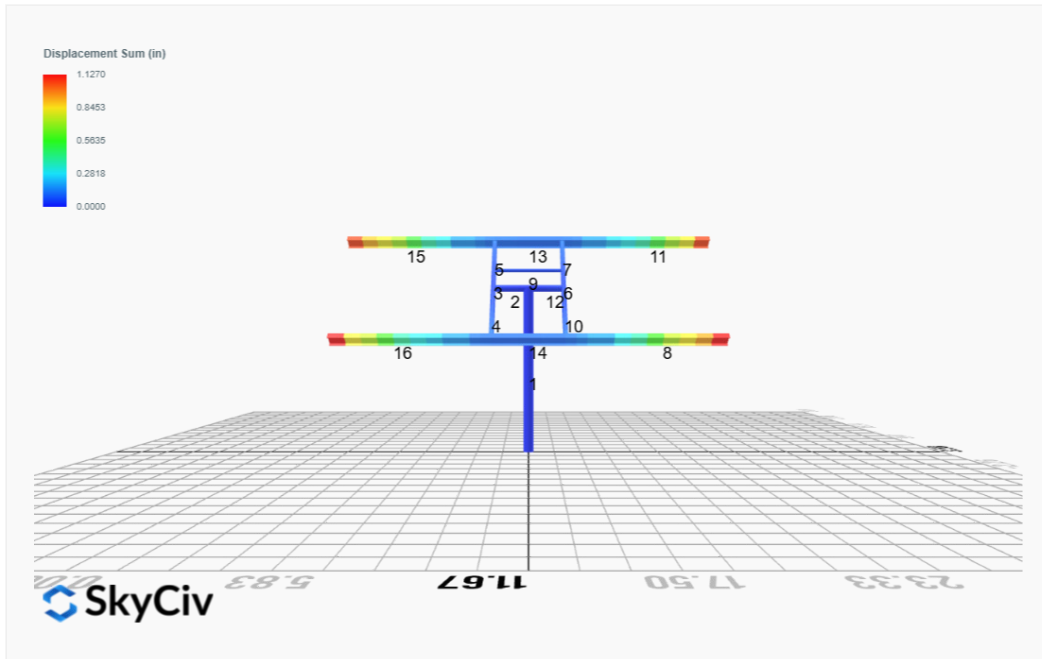

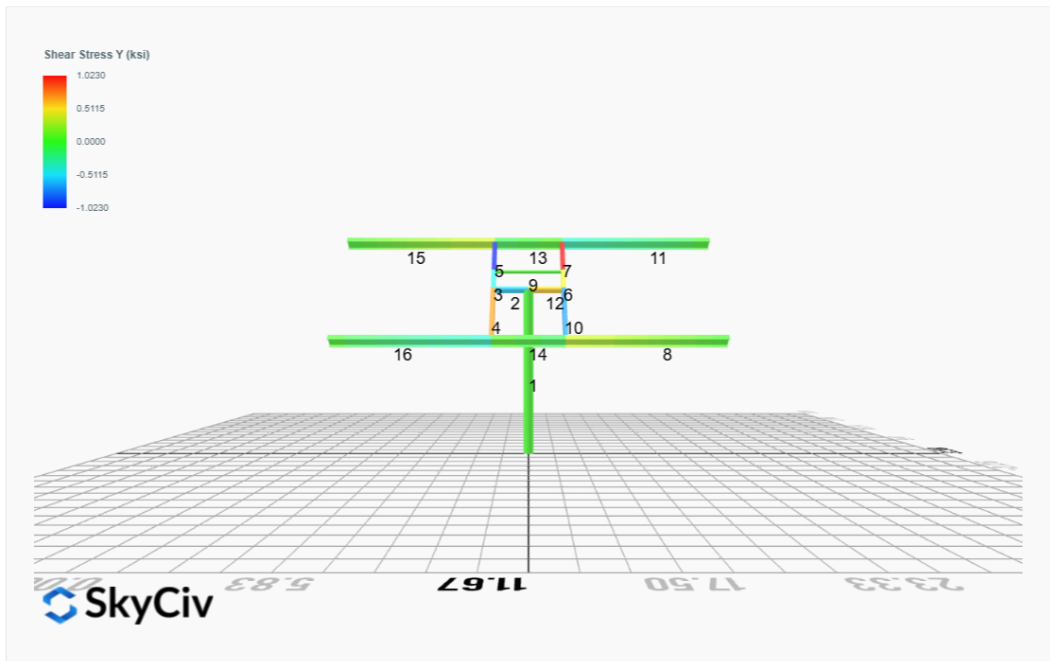
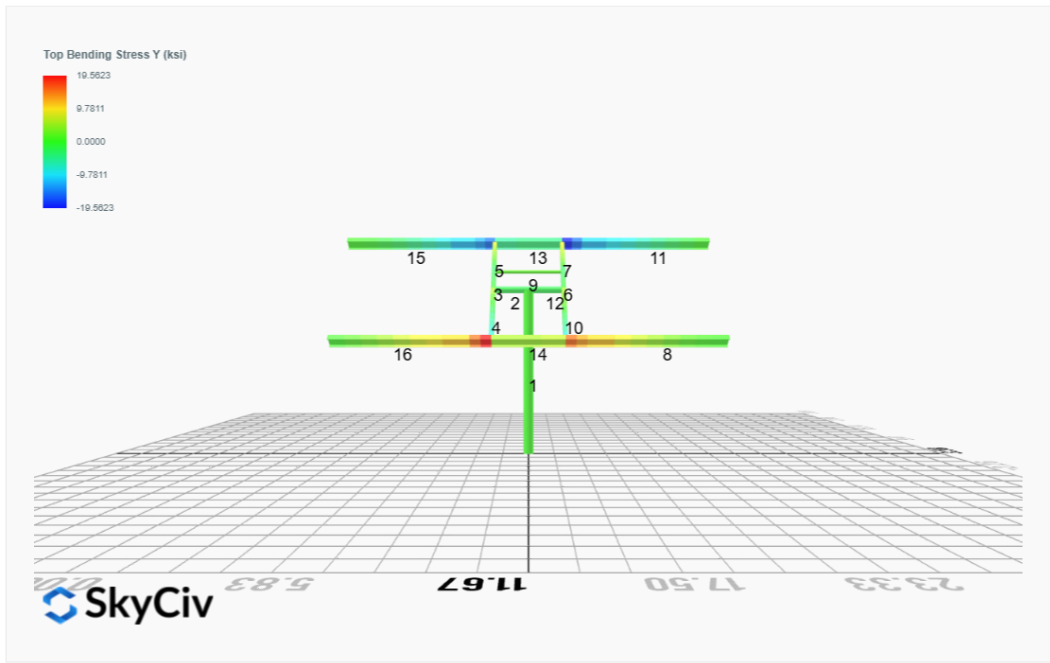

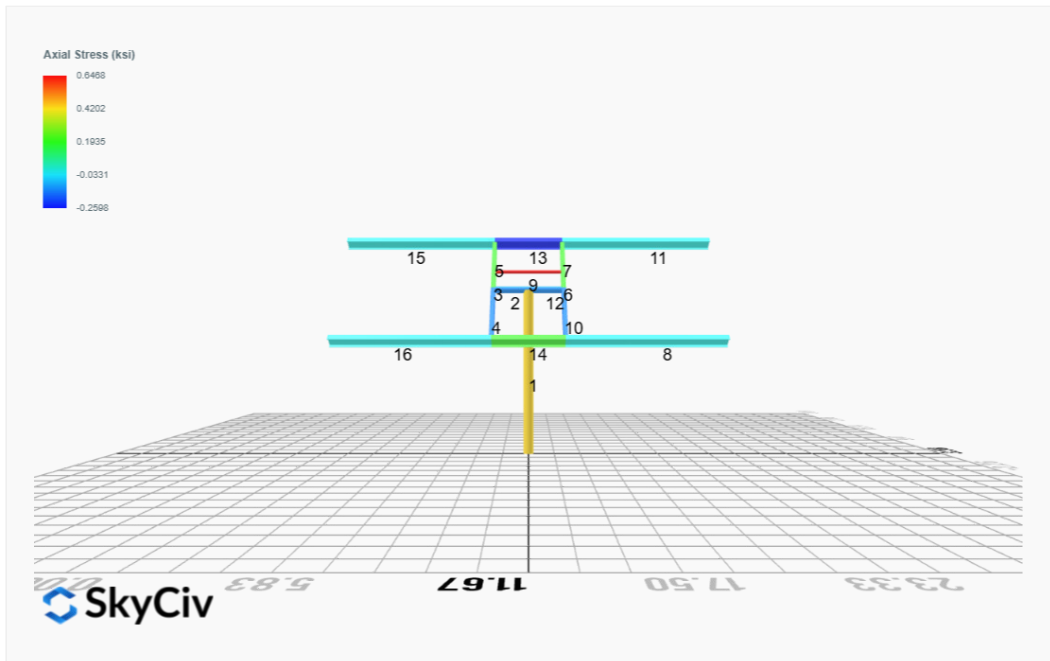

Reaction Forces for Foundation 1 (Node ID#1), (kip, kip-ft)

ASD Load Combination Results

Name	Fx	Fy	Fz	Mx	My	Mz
ULS: 1. D	0.0000	2.0991	0.0000	0.0000	-0.0000	0.0208
ULS: 2. D + L	0.0000	2.0991	0.0000	0.0000	-0.0000	0.0208
ULS: 3. D + (S or Lr or R)	0.0000	4.6351	0.0000	0.0000	-0.0000	0.0291
ULS: 3. D + (S or Lr or R)	0.0000	2.0991	0.0000	0.0000	-0.0000	0.0208
ULS: 4. D + 0.75L + 0.75(S or Lr or R)	0.0000	4.0011	0.0000	0.0000	-0.0000	0.0270
ULS: 4. D + 0.75L + 0.75(S or Lr or R)	0.0000	2.0991	0.0000	0.0000	-0.0000	0.0208
ULS: 5b. D + 0.7E	0.0000	2.0991	0.0000	0.0000	-0.0000	0.0208
ULS: 6b. D + 0.75L + 0.75(0.7)E + 0.75S	0.0000	4.0011	0.0000	0.0000	-0.0000	0.0270
ULS: 8. 0.6D + 0.7E	0.0000	1.2595	0.0000	0.0000	-0.0000	0.0125
ULS: 5a. D + 0.6W_Wind downforce Case A only	-2.2429	3.9811	0.0000	0.0000	-0.0000	21.1276
ULS: 5a. D + 0.6W_Wind downforce Case B only	0.0000	2.0991	0.0000	0.0000	-0.0000	0.0208
ULS: 5a. D + 0.6W_Wind uplift Case A only	2.2429	0.2171	0.0000	0.0000	-0.0000	-20.4284
ULS: 5a. D + 0.6W_Wind uplift Case B only	0.0000	2.0991	0.0000	0.0000	-0.0000	0.0208
ULS: 6a. D + 0.75L + 0.75(0.6)W + 0.75(S or Lr or R)_Wind downforce Case A only	-1.6822	5.4126	0.0000	0.0000	-0.0000	15.8571
ULS: 6a. D + 0.75L + 0.75(0.6)W + 0.75(S or Lr or R)_Wind downforce Case B only	0.0000	4.0011	0.0000	0.0000	-0.0000	0.0270
ULS: 6a. D + 0.75L + 0.75(0.6)W + 0.75(S or Lr or R)_Wind uplift Case A only	1.6822	2.5896	0.0000	0.0000	-0.0000	-15.3099
ULS: 6a. D + 0.75L + 0.75(0.6)W + 0.75(S or Lr or R)_Wind uplift Case B only	0.0000	4.0011	0.0000	0.0000	-0.0000	0.0270
ULS: 6a. D + 0.75L + 0.75(0.6)W + 0.75(S or Lr or R)_Wind downforce Case A only	-1.6822	3.5106	0.0000	0.0000	-0.0000	15.8509
ULS: 6a. D + 0.75L + 0.75(0.6)W + 0.75(S or Lr or R)_Wind downforce Case B only	0.0000	2.0991	0.0000	0.0000	-0.0000	0.0208
ULS: 6a. D + 0.75L + 0.75(0.6)W + 0.75(S or Lr or R)_Wind uplift Case A only	1.6822	0.6876	0.0000	0.0000	-0.0000	-15.3161
ULS: 6a. D + 0.75L + 0.75(0.6)W + 0.75(S or Lr or R)_Wind uplift Case B only	0.0000	2.0991	0.0000	0.0000	-0.0000	0.0208
ULS: 7. 0.6D + 0.6W_Wind downforce Case A only	-2.2429	3.1415	0.0000	0.0000	-0.0000	21.1193
ULS: 7. 0.6D + 0.6W_Wind downforce Case B only	0.0000	1.2595	0.0000	0.0000	-0.0000	0.0125
ULS: 7. 0.6D + 0.6W_Wind uplift Case A only	2.2429	-0.6226	0.0000	0.0000	-0.0000	-20.4368
ULS: 7. 0.6D + 0.6W_Wind uplift Case B only	0.0000	1.2595	0.0000	0.0000	-0.0000	0.0125

Worst Case Reactions LRFD

These calculations are taken directly from the FEA via SkyCiv and are used in the Concrete Checks of the Foundation Module.

Note: Worst case values are assumed as downforce wind load cases.

Result	Value (kip, kip-ft)
Axial	8.1449
Shear X	-3.7382
Shear Z	0.0000
Moment X	0.0000
Moment Y (Twist)	0.0000
Moment Z	35.9558

Worst Case Reactions ASD

These results are taken from the worst case values in the above table and are used in the Soil Checks in the Foundation Module.

Note: Worst case values are assumed as downforce wind load cases.

Result	Value (kip, kip-ft)
Axial	5.4126
Shear X	-2.2429
Shear Z	0.0000
Moment X	0.0000
Moment Y (Twist)	0.0000
Moment Z	21.1276

Project Details

Design Code: AISC 360-16 LRFD
 Provision: LRFD
 Country: United States

 User Name: sales@mtsolar.us
 Project Name: MTSOLAR_3JJH9A34K8378
 Unit System: imperial



Design Input Information

Design Factors			
Φ_t	Φ_c	Φ_b	Φ_v
0.9	0.9	0.9	0.9

Design Materials			
ID	E (ksi)	F_y (ksi)	F_u (ksi)
1	29000	50	65

Section Dimensions

ID	Name	d (in)	t_w (in)				
2	2in Pipe Sch 80	2.38	0.22				
5	4in Pipe Sch 80	4.50	0.34				
7	6in Pipe Sch 40	6.63	0.28				

ID	Name	d (in)	b (in)	t_w (in)	t_b (in)	r (in)	
16	HSS5x3x3/16	5.00	3.00	0.17	0.17	0.17	

ID	Name	d (in)	t_w (in)	b_t (in)	b_b (in)	t_t (in)	t_b (in)	r (in)
19	W8x10	7.89	0.17	3.94	3.94	0.20	0.20	0.30

Section Properties								
ID	Name	A (in ²)	J (in ⁴)	I_{y0} (in ⁴)	I_{z0} (in ⁴)	I_w (in ⁶)	S_{y0} (in ³)	S_{z0} (in ³)

14	133.20	85.85	23.29	6.12	40.24	43.62
15	133.20	15.17	32.87	6.12	40.24	43.62
16	133.20	15.17	32.87	6.12	40.24	43.62

Design Ratio

Member ID	P	M _z	M _y	V _y	V _z	(P,M _z ,M _y)	Worst LC	KL/r	δ	Status
1	0.071	0.850	0.000	0.050	0.000	0.880	#13	0.520	Not Required	Pass
2	0.009	0.272	0.185	0.067	0.031	0.435	#13	0.035	Not Required	Pass
3	0.010	0.426	0.078	0.042	0.018	0.444	#13	0.045	Not Required	Pass
4	0.010	0.423	0.291	0.042	0.058	0.553	#21	0.080	Not Required	Pass
5	0.010	0.264	0.305	0.042	0.079	0.329	#21	0.074	Not Required	Pass
6	0.010	0.426	0.078	0.042	0.018	0.444	#13	0.045	Not Required	Pass
7	0.010	0.264	0.305	0.042	0.079	0.329	#21	0.074	Not Required	Pass
8	0.000	0.122	0.436	0.028	0.017	0.546	#21	Not Required	Not Required	Pass
9	0.039	0.031	0.049	0.001	0.000	0.089	#21	0.204	Not Required	Pass
10	0.010	0.423	0.291	0.042	0.058	0.553	#21	0.080	Not Required	Pass
11	0.000	0.122	0.436	0.028	0.017	0.546	#21	Not Required	Not Required	Pass
12	0.009	0.272	0.185	0.067	0.031	0.435	#13	0.035	Not Required	Pass
13	0.014	0.273	0.681	0.035	0.022	0.924	#21	0.190	Not Required	Pass
14	0.016	0.277	0.681	0.035	0.022	0.924	#21	0.190	Not Required	Pass
15	0.000	0.122	0.436	0.028	0.017	0.546	#21	Not Required	Not Required	Pass
16	0.000	0.122	0.436	0.028	0.017	0.546	#21	Not Required	Not Required	Pass

Definitions

Φ _t	Safety factor for tensile
Φ _c	Safety factor for compression
Φ _b	Safety factor for flexure
Φ _v	Safety factor for shear
E	Modulus of elasticity
F _y	Specified minimum yield stress
F _u	Specified minimum tensile strength
A	Cross-sectional area
J	Torsional constant
I _{yp}	Moment of inertia about the Y axes
I _{zp}	Moment of inertia about the Z axes
I _w	Warping constant
S _{yp}	Plastic section modulus about the Y axis
S _{zp}	Plastic section modulus about the Z axis
KL	Effective length
C _b	Buckling modification factor (from all load combinations)
L _b	Length between braced points
LST	Limited slenderness for tension
LSC	Limited slenderness for compression
LD	Limited deflection
P _n	Nominal axial strength (tension/compression)
M _n	Nominal flexural strength (about Z/Y axis)
V _n	Nominal shear strength (along Z/Y axis)
P	Design ratio in case of axial force
M _z	Design ratio in case of bending about Z axis
M _y	Design ratio in case of bending about Y axis
V _y	Design ratio in case of shear along Y axis
V _z	Design ratio in case of shear along Z axis
(P,M _z ,M _y)	Design ratio in case of axial force and bending action
KL/r	Design ratio in case of section slenderness
δ	Design ratio in case of member deflection
OK	Capacity is provided
NG	Capacity is not provided

REFERENCES	CALCULATIONS	RESULTS
------------	--------------	---------

SkyCiv Foundation Design

Pile Foundation

Design Information :

Design code : IBC 2021 (International Building Code)
Unit System : Imperial

Pile Input

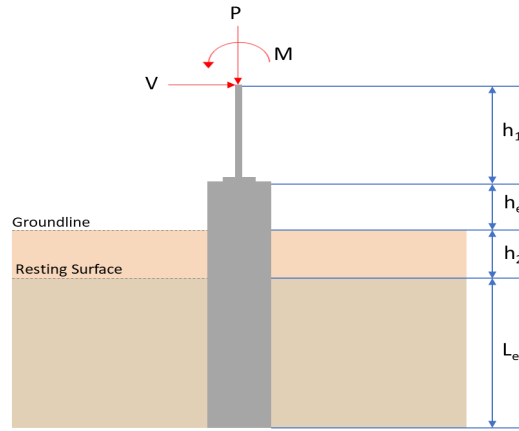

Geometry

Pile shape: round

$D = 36$ in - Pile diameter

$L = 8$ ft - Total pile length

$h_1 = 0$ ft - Lateral load height from the top of the pile,

$h_2 = 0$ ft - Depth to resisting surface

$h_e = 0$ ft - Length of pile above the ground

Tabulation of Soil Parameters

Layer	Label	Allowable Bearing Pressure (q_a) (psf)	Allowable Lateral Pressure (R) (psf/ft)
1	Sand, silty sand, clayey sand, silty gravel & clayey gravel	2000.000	150.000

Tabulation of Loads

Load Component	ASD	LRFD
P (kip)	5.413	8.145
V_x (kip)	-2.243	-3.738
V_z (kip)	0.000	0.000
M_x (kipft)	0.000	0.000
M_z (kipft)	21.128	35.956

Material Properties

$f'_{ck} = 2.5$ ksi - Concrete strength,

Required depth to resist lateral loads (ASD)

H - Point of application of the lateral load

$$H = h_1 + h_2 + h_e$$

$$H = (0 \text{ ft}) + (0 \text{ ft}) + (0 \text{ ft})$$

$$H = 0 \text{ ft}$$

Considering x-direction:

H_o - Lateral force per length of pile,

$$H_o = \frac{V_x}{D}$$

$$H_o = \frac{(-2.243 \text{ kip})}{(36 \text{ in})}$$

$$H_o = -0.74767 \text{ kip/ft}$$

M_o - Moment per length of pile,

$$M_o = \frac{M_z + (V_x H)}{D}$$

$$M_o = \frac{(21.128 \text{ kipft}) + ((-2.243 \text{ kip}) \times (0 \text{ ft}))}{(36 \text{ in})}$$

$$M_o = 7.0427 \text{ kipft/ft}$$

Required depth of embedment in earth:

$$L_x^3 - \left(14.14 \times \frac{H_o \times L_x}{R}\right) - \left(18.85 \times \frac{M_o}{R}\right) = 0$$

Solving the cubic equation:

$L_{e,x} = 7.2191 \text{ ft}$ - Required depth in x-direction,

Considering z-direction:

$L_{e,z} = 0 \text{ ft}$ - Required depth in z-direction,

Minimum embedded depth required:

$L_{e,req}$ - Depth of pile required,

$$L_{e,req} = \text{MAX}[L_{e,x}, L_{e,z}]$$

$$L_{e,req} = \text{MAX}[(7.2191 \text{ ft}), (0 \text{ ft})]$$

$$L_{e,req} = 7.219 \text{ ft}$$

L_e - Actual embedded length of pile,

$$L_e = L - h_e - h_2$$

$$L_e = (8 \text{ ft}) - (0 \text{ ft}) - (0 \text{ ft})$$

$$L_e = 8 \text{ ft}$$

Ratio - Embedded depth

$$\text{Ratio} = \frac{L_{e,req}}{L_e}$$

$$\text{Ratio} = \frac{(7.219 \text{ ft})}{(8 \text{ ft})}$$

$$\text{Ratio} = 0.90238$$

Status: **PASS**
Ratio: **0.900**

End-bearing Capacity (ASD)

A - Pile cross-section area

$$A = \pi \left(\frac{D}{2}\right)^2$$

$$A = \pi \times \left(\frac{(36 \text{ in})}{2}\right)^2$$

$$A = 7.0686 \text{ ft}^2$$

q - End-bearing pressure

$$q = \frac{P_v}{A}$$

$$q = \frac{(5.413 \text{ kip})}{(7.0686 \text{ ft}^2)}$$

$$q = 0.76578 \text{ kip/ft}^2$$

Check bearing capacity ratio:

Ratio - Capacity

$$\text{Ratio} = \frac{q}{q_a}$$

$$\text{Ratio} = \frac{(0.76578 \text{ kip/ft}^2)}{(2000 \text{ psf})}$$

$$\text{Ratio} = 0.38289$$

Status: **PASS**
Ratio: **0.380**

Czerniak

Lateral Soil Pressure (ASD):

L/D - Length to least lateral dimension ratio,

$$L/D = \frac{L}{D}$$

$$L/D = \frac{(8 \text{ ft})}{(36 \text{ in})}$$

$$L/D = 2.6667$$

Since $L/D \leq 10$,

Pile is short.

Considering x-direction:

$H_o = -0.74767$ kip/ft - Lateral force per length of pile,

$M_o = 7.0427$ kipft/ft - Overturning moment per length of pile,

a - Distance from resting surface to pivot point,

$$a = \frac{(4 M_o L_e) + (3 H_o L_e^2)}{(6 M_o) + (4 H_o L_e)}$$

$$a = \frac{(4 \times (7.0427 \text{ kipft/ft}) \times (8 \text{ ft})) + (3 \times (-0.74767 \text{ kip/ft}) \times (8 \text{ ft})^2)}{(6 \times (7.0427 \text{ kipft/ft})) + (4 \times (-0.74767 \text{ kip/ft}) \times (8 \text{ ft}))}$$

$$a = 5.5743 \text{ ft}$$

p - Earth pressure against the pile at distance $a/2$ from resting surface,

$$p = \frac{1.178 [(4 M_o) + (3 H_o L_e)]^2}{L_e^2 [(3 M_o) + (2 H_o L_e)]}$$

$$p = \frac{1.178 \times [(4 \times (7.0427 \text{ kipft/ft})) + (3 \times (-0.74767 \text{ kip/ft}) \times (8 \text{ ft}))]^2}{(8 \text{ ft})^2 \times [(3 \times (7.0427 \text{ kipft/ft})) + (2 \times (-0.74767 \text{ kip/ft}) \times (8 \text{ ft}))]}$$

$$p = 0.21003 \text{ kip/ft}^2$$

s - Earth pressure against the pile at distance L_e ,

$$s = \frac{9.425 [(2 M_o) + (H_o L_e)]}{L_e^2}$$

$$s = \frac{9.425 \times [(2 \times (7.0427 \text{ kipft/ft})) + ((-0.74767 \text{ kip/ft}) \times (8 \text{ ft}))]}{(8 \text{ ft})^2}$$

$$s = 1.1934 \text{ kip/ft}^2$$

Check lateral soil pressure capacity:

p_a - Allowable lateral soil pressure at depth $a/2$,

$$p_a = R \frac{a}{2}$$

$$p_a = (150 \text{ psf/ft}) \times \frac{(5.5743 \text{ ft})}{2}$$

$$p_a = 0.41808 \text{ kip/ft}^2$$

Ratio - Lateral soil capacity

$$\text{Ratio} = \frac{p}{p_a}$$

$$\text{Ratio} = \frac{(0.21003 \text{ kip/ft}^2)}{(0.41808 \text{ kip/ft}^2)}$$

$$\text{Ratio} = 0.50238$$

p_s - Allowable lateral soil pressure at depth L_e ,

$$p_s = R L_e$$

$$p_s = (150 \text{ psf/ft}) \times (8 \text{ ft})$$

$$p_s = 1.2 \text{ kip/ft}^2$$

Ratio - Lateral soil capacity

$$\text{Ratio} = \frac{s}{p_s}$$

$$(1.1934 \text{ kip/ft}^2)$$

Status: **PASS**
Ratio: **0.500**

$$\text{Ratio} = \frac{\dots}{(1.2 \text{ kip/ft}^2)}$$

$$\text{Ratio} = 0.99453$$

Status: **PASS**
Ratio: **0.990**

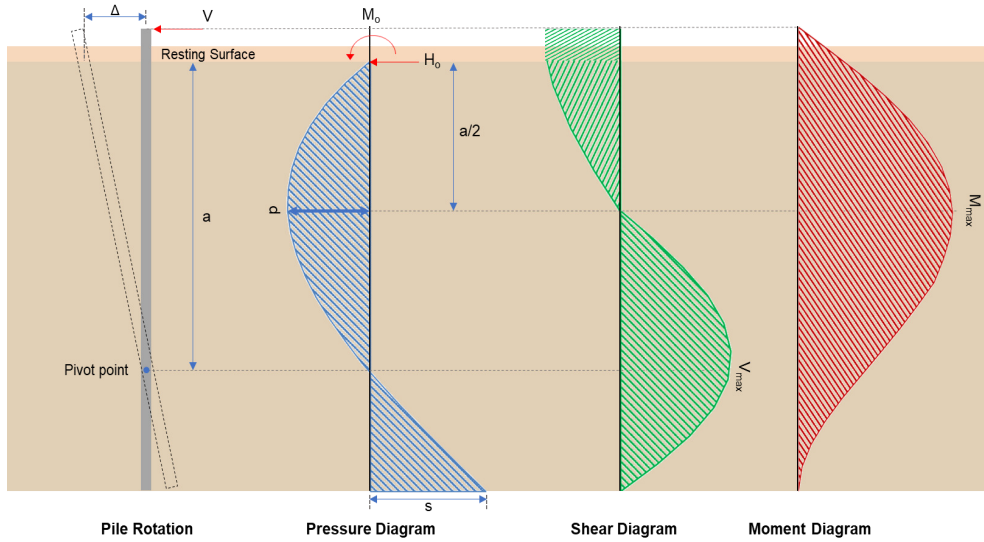

Shear force and Bending moment (x-direction, LRFD)

H_o - Lateral force per length of pile,

$$H_o = \frac{V_x}{D}$$

$$H_o = \frac{(-3.738 \text{ kip})}{(36 \text{ in})}$$

$$H_o = -1.246 \text{ kip/ft}$$

M_o - Moment per length of pile,

$$M_o = \frac{M_z + (V_x H)}{D}$$

$$M_o = \frac{(35.956 \text{ kipft}) + ((-3.738 \text{ kip}) \times (0 \text{ ft}))}{(36 \text{ in})}$$

$$M_o = 11.985 \text{ kipft/ft}$$

E - Distance from lateral load to resisting surface,

$$E = \frac{M_o}{H_o}$$

$$E = \frac{(11.985 \text{ kipft/ft})}{(-1.246 \text{ kip/ft})}$$

$$E = 9.619 \text{ ft}$$

a - Distance from resting surface to pivot point,

$$a = \frac{(4 M_o L_e) + (3 H_o L_e^2)}{(6 M_o) + (4 H_o L_e)}$$

$$a = \frac{(4 \times (11.985 \text{ kipft/ft}) \times (8 \text{ ft})) + (3 \times (-1.246 \text{ kip/ft}) \times (8 \text{ ft})^2)}{(6 \times (11.985 \text{ kipft/ft})) + (4 \times (-1.246 \text{ kip/ft}) \times (8 \text{ ft}))}$$

$$a = 5.5711 \text{ ft}$$

V_{max} - Max shear force located at depth a ,

$$V_{max} = (H_o D) \left[1 - \left[3 \left(\frac{4E}{L_e} + 3 \right) \left(\frac{a}{L_e} \right)^2 + 4 \left(\frac{3E}{L_e} + 2 \right) \left(\frac{a}{L_e} \right)^3 \right] \right]$$

$$V_{max} = ((-1.246 \text{ kip/ft}) \times (36 \text{ in})) \times \left[1 - \left[3 \times \left(\frac{4 \times (9.619 \text{ ft})}{(8 \text{ ft})} + 3 \right) \times \left(\frac{(5.5711 \text{ ft})}{(8 \text{ ft})} \right)^2 + 4 \times \left(\frac{3 \times (9.619 \text{ ft})}{(8 \text{ ft})} + 2 \right) \times \left(\frac{(5.5711 \text{ ft})}{(8 \text{ ft})} \right)^3 \right] \right]$$

$$V_{max} = 10.419 \text{ kip}$$

M_{max} - Max bending moment located at depth $a/2$,

$$M_{max} = (H_o D L_e) \left[\left(\frac{E}{L_e} + \frac{a}{2 L_e} \right) - \left[\left(\frac{4E}{L_e} + 3 \right) \left(\frac{a}{2 L_e} \right)^3 + \left[\left(\frac{3E}{L_e} + 2 \right) \left(\frac{a}{2 L_e} \right)^4 \right] \right] \right]$$

$$M_{max} = ((-1.246 \text{ kip/ft}) \times (36 \text{ in}) \times (8 \text{ ft})) \times \left[\left(\frac{(9.619 \text{ ft})}{(8 \text{ ft})} + \frac{(5.5711 \text{ ft})}{2 \times (8 \text{ ft})} \right) - \left[\left(\frac{4 \times (9.619 \text{ ft})}{(8 \text{ ft})} + 3 \right) \times \left(\frac{(5.5711 \text{ ft})}{2 \times (8 \text{ ft})} \right)^3 + \left[\left(\frac{3 \times (9.619 \text{ ft})}{(8 \text{ ft})} + 2 \right) \times \left(\frac{(5.5711 \text{ ft})}{2 \times (8 \text{ ft})} \right)^4 \right] \right] \right]$$

$$M_{max} = 38.974 \text{ kipft}$$

Minimum Reinforcement Check (LRFD)

Parameters:

$f'_{ck} = 2.5 \text{ ksi}$ - Concrete strength,

$f_{yk} = 60 \text{ ksi}$ - Longitudinal reinforcement strength,

$\phi = 0.65$ - Reduction factor for axial strength,

$\alpha = 0.85$ - Alpha factor for axial strength,

$A_g = 1017.9 \text{ in}^2$ - Gross area of concrete,

Table 22.4.2.1

Longitudinal reinforcement:

Required reinforcement due to axial load, $A_{st,required}$

22.4.2.2, 10.6.1.1

$A_{st,required}$

$$A_{st,required} = \text{Min} \left[\frac{\frac{P}{\phi \alpha} - (0.85 f'_{ck} A_g)}{f_{yk} - (0.85 f'_{ck})}, (0.08 A_g) \right]$$

$$A_{st,required} = \text{Min} \left[\frac{\frac{(8.145 \text{ kip})}{(0.65) \times (0.85)} - (0.85 \times (2.5 \text{ ksi}) \times (1017.9 \text{ in}^2))}{(60 \text{ ksi}) - (0.85 \times (2.5 \text{ ksi}))}, (0.08 \times (1017.9 \text{ in}^2)) \right]$$

$$A_{st,required} = -37.119 \text{ in}^2$$

A_{min} - Governing minimum reinforcement area,

$$A_{min} = \text{Max} [A_{st,required}, (0.0018 A_g)]$$

$$A_{min} = \text{Max} [(-37.119 \text{ in}^2), (0.0018 \times (1017.9 \text{ in}^2))]$$

$$A_{min} = 1.8322 \text{ in}^2$$

n_{rebar} - Required number of reinforcement,

$$n_{rebar} = \frac{A_{min}}{A_{rebar}}$$

$$n_{rebar} = \frac{(1.8322 \text{ in}^2)}{(0.3068 \text{ in}^2)}$$

$$n_{rebar} = 6$$

A_{st} - Actual total reinforcement area,

$$A_{st} = n_{rebar} \frac{\pi d_{bar}^2}{4}$$

$$A_{st} = (6) \times \frac{\pi \times (0.625 \text{ in})^2}{4}$$

$$A_{st} = 1.8408 \text{ in}^2$$

Ratio - Capacity

$$\text{Ratio} = \frac{A_{min}}{A_{st}}$$

$$\text{Ratio} = \frac{(1.8322 \text{ in}^2)}{(1.8408 \text{ in}^2)}$$

$$\text{Ratio} = 0.99533$$

25.2.3

s_{rebar} - Minimum spacing of reinforcement,

Status: **PASS**
Ratio: **1.000**

<p>25.7.2.2 25.7.2.1</p>	<p style="text-align: center;">$s_{rebar} = Max [1.5, (1.5 d_{bar})]$</p> <p style="text-align: center;">$s_{rebar} = Max [1.5, (1.5 \times (0.625 \text{ in}))]$</p> <p style="text-align: center;">$s_{rebar} = 1.5 \text{ in}$</p> <p>Ties: Since longitudinal reinforcement is \leq No. 10e: Use #3(0.375 in) s_{ties} - Maximum center-to-center spacing of ties,</p> <p style="text-align: center;">$s_{ties} = Min [(16 d_{bar}), (48 d_{ties}), D]$</p> <p style="text-align: center;">$s_{ties} = Min [(16 \times (0.625 \text{ in})), (48 \times (0.375 \text{ in})), (36 \text{ in})]$</p> <p style="text-align: center;">$s_{ties} = 10 \text{ in}$</p> <p>Summary:</p> <p style="text-align: center;">Main reinforcement: 6 - #5 (0.625 in) Ties: #3(0.375 in) - 10 in</p>	
<p>22.4.2.2</p>	<p>Axial Compression Strength (ACI 318-19, LRFD)</p> <p>ϕP_N - Allowable axial compressive strength</p> <p style="text-align: center;">$\phi P_N = \phi 0.85 [(0.85 f'_{ck} [A_g - A_{st}]) + (f_{yk} A_{st})]$</p> <p style="text-align: center;">$\phi P_N = (0.65) \times 0.85 \times [(0.85 \times (2.5 \text{ ksi}) \times [(1017.9 \text{ in}^2) - (1.8408 \text{ in}^2)]) + ((60 \text{ ksi}) \times (1.8408 \text{ in}^2))]$</p> <p style="text-align: center;">$\phi P_N = 1253.9 \text{ kip}$</p> <p>Ratio - Capacity</p> <p style="text-align: center;">$Ratio = \frac{P}{\phi P_N}$</p> <p style="text-align: center;">$Ratio = \frac{(8.145 \text{ kip})}{(1253.9 \text{ kip})}$</p> <p style="text-align: center;">$Ratio = 0.0064957$</p>	<p>Status: PASS Ratio: 0.010</p>
<p>22.5.2.2 22.5.5.1.3 22.5.5.1.1 22.5.5.1.1(a)</p>	<p>Shear Strength (ACI 318-19, LRFD)</p> <p>Parameters: $b_w = 36 \text{ in}$ - Effective width, d - Effective depth</p> <p style="text-align: center;">$d = 0.80 D$</p> <p style="text-align: center;">$d = 0.80 \times (36 \text{ in})$</p> <p style="text-align: center;">$d = 28.8 \text{ in}$</p> <p>λ_s - size effect modification factor</p> <p style="text-align: center;">$\lambda_s = MIN \left[\sqrt{\frac{2}{1 + \frac{d}{10}}}, 1 \right]$</p> <p style="text-align: center;">$\lambda_s = MIN \left[\sqrt{\frac{2}{1 + \frac{(28.8 \text{ in})}{10}}}, 1 \right]$</p> <p style="text-align: center;">$\lambda_s = 0.71796$</p> <p>The following variables were converted to be consistent with empirical formula $f'_{ck} = 2.5 \text{ ksi} \rightarrow 2500 \text{ psi}$,</p> <p>$V_{c,max}$ - Max shear strength of concrete</p> <p style="text-align: center;">$V_{c,max} = 5 \lambda_s \sqrt{f'_{ck}} b_w d$</p> <p style="text-align: center;">$V_{c,max} = 5 \times (0.71796) \times \sqrt{(2500 \text{ psi})} \times (36 \text{ in}) \times (28.8 \text{ in})$</p> <p style="text-align: center;">$V_{c,max} = 186.09 \text{ kip}$</p> <p>The following variables were converted to be consistent with empirical formula $f'_{ck} = 2.5 \text{ ksi} \rightarrow 2500 \text{ psi}$, $P = 8.145 \text{ kip} \rightarrow 8145 \text{ lbf}$,</p> <p>$V_{c,a}$ - Shear strength of concrete (a)</p> <p style="text-align: center;">$V_{c,a} = \left[2 \lambda_s \sqrt{f'_{ck}} + \frac{P}{6 A_g} \right] b_w d$</p>	

$$V_{c,a} = \left[2 \times (0.71796) \times \sqrt{(2500 \text{ psi})} + \frac{(8145 \text{ lbf})}{6 \times (1017.9 \text{ in}^2)} \right] \times (36 \text{ in}) \times (28.8 \text{ in})$$

$$V_{c,a} = 75.821 \text{ kip}$$

22.5.5.1.2 The following variables were converted to be consistent with empirical formula $f'_{ck} = 2.5 \text{ ksi} \rightarrow 2500 \text{ psi}$,
 $V_{c,b}$ - Shear strength of concrete (b)

$$V_{c,b} = \left[2 \lambda_s \sqrt{f'_{ck}} + (0.05 f'_{ck}) \right] b_w d$$

$$V_{c,b} = \left[2 \times (0.71796) \times \sqrt{(2500 \text{ psi})} + (0.05 \times (2500 \text{ psi})) \right] \times (36 \text{ in}) \times (28.8 \text{ in})$$

$$V_{c,b} = 204.04 \text{ kip}$$

V_c - Governing shear strength of concrete

$$V_c = \text{Min} [V_{c,max}, V_{c,a}, V_{c,b}]$$

$$V_c = \text{Min} [(186.09 \text{ kip}), (75.821 \text{ kip}), (204.04 \text{ kip})]$$

$$V_c = 75.821 \text{ kip}$$

22.5.1.2 The following variables were converted to be consistent with empirical formula $f'_{ck} = 2.5 \text{ ksi} \rightarrow 2500 \text{ psi}$,
 $V_{s,a}$ - Shear strength of steel (a)

$$V_{s,a} = 8 \sqrt{f'_{ck}} b_w d$$

$$V_{s,a} = 8 \times \sqrt{(2500 \text{ psi})} \times (36 \text{ in}) \times (28.8 \text{ in})$$

$$V_{s,a} = 414.72 \text{ kip}$$

A_v - Ties rebar area,

$$A_v = \frac{\pi d_{ties}^2}{4}$$

$$A_v = \frac{\pi \times (0.375 \text{ in})^2}{4}$$

$$A_v = 0.11045 \text{ in}^2$$

22.5.8.5.3 $V_{s,b}$ - Shear strength of steel (b)

$$V_{s,b} = \frac{2 A_v f_{yw} d}{s_{ties}}$$

$$V_{s,b} = \frac{2 \times (0.11045 \text{ in}^2) \times (60 \text{ ksi}) \times (28.8 \text{ in})}{(10 \text{ in})}$$

$$V_{s,b} = 38.17 \text{ kip}$$

V_s - Governing shear strength of steel

$$V_s = \text{MIN} [V_{s,a}, V_{s,b}]$$

$$V_s = \text{MIN} [(414.72 \text{ kip}), (38.17 \text{ kip})]$$

$$V_s = 38.17 \text{ kip}$$

22.5.1.1 ϕV_n - Allowable shear strength

$$\phi V_n = \phi (V_c + V_s)$$

$$\phi V_n = (0.65) \times ((75.821 \text{ kip}) + (38.17 \text{ kip}))$$

$$\phi V_n = 74.094 \text{ kip}$$

Considering x-direction:

$V_{max} = 10.419 \text{ kip}$ - Maximum shear force in the x-direction,

Ratio - Capacity

$$\text{Ratio} = \frac{V_{max}}{\phi V_n}$$

$$\text{Ratio} = \frac{(10.419 \text{ kip})}{(74.094 \text{ kip})}$$

$$\text{Ratio} = 0.14062$$

Flexural Strength (ACI 318-19, LRFD) S_m - Section modulus

$$S_m = \frac{\pi D^3}{32}$$

$$S_m = \frac{\pi \times (36 \text{ in})^3}{32}$$

$$S_m = 4580.4 \text{ in}^3$$

 $\lambda = 1$ - Concrete modification factor (Normal concrete),

Allowable flexural strength:

 M_n shall be the lesser of: $\phi M_{n,1}$

$$\phi M_{n,1} = \phi \times 5 \times \lambda \times \sqrt{f'_c} \times S_m$$

$$\phi M_{n,1} = 0.65 \times 5 \times 1 \times \sqrt{2.5 \text{ ksi}} \times 4580.442 \text{ in}^3$$

$$\phi M_{n,1} = 62.027 \text{ kipft}$$

14.5.2.1b

 $\phi M_{n,2}$

$$\phi M_{n,2} = \phi \times 0.85 f'_c S_m$$

$$\phi M_{n,2} = (0.65) \times 0.85 \times (2.5 \text{ ksi}) \times (4580.4 \text{ in}^3)$$

$$\phi M_{n,2} = 527.23 \text{ kipft}$$

Therefore,

 ϕM_n - Allowable flexural strength,

$$\phi M_n = \text{MIN}[\phi M_{n,1}, \phi M_{n,2}]$$

$$\phi M_n = \text{MIN}[(62.027 \text{ kipft}), (527.23 \text{ kipft})]$$

$$\phi M_n = 62.027 \text{ kipft}$$

Considering x-direction: $M_{max} = 38.974 \text{ kipft}$ - Maximum moment in the x-direction,

Ratio - Capacity

$$\text{Ratio} = \frac{M_{max}}{\phi M_n}$$

$$\text{Ratio} = \frac{(38.974 \text{ kipft})}{(62.027 \text{ kipft})}$$

$$\text{Ratio} = 0.62835$$

Status: **PASS**
Ratio: **0.630**