

Project Name: Unleashed **Date:** Fri Oct 10 2025
Location: Madison, WI, USA **Number of Modules:** 12
Unique ID: 1P-0-8TOP-HD-84-L-4Hx3W-953J **Number of Poles:** 1
Dealer: _____ **Date Sold:** _____

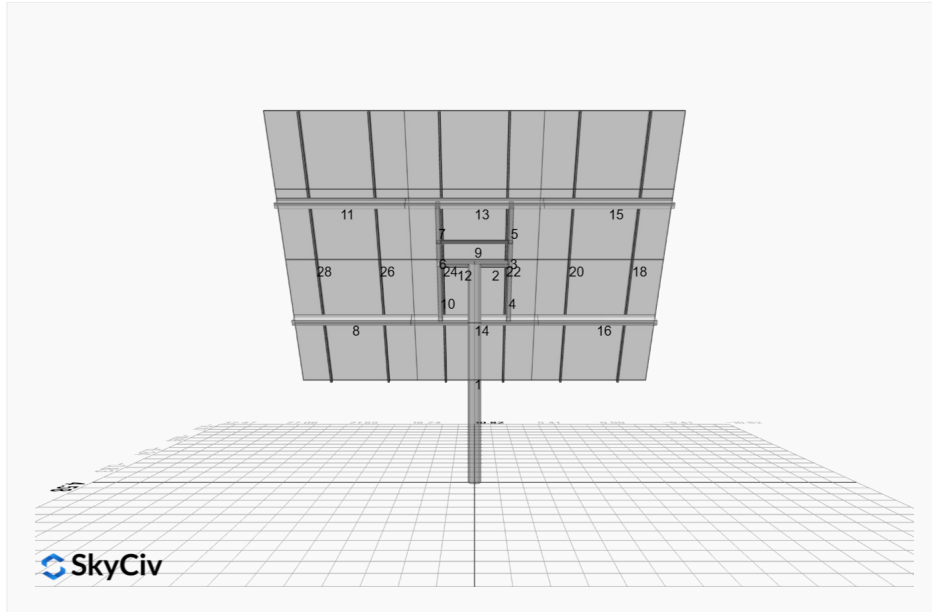

Array Dimensions N/S	17.30 ft
Array Dimensions E/W	21.65 ft
Winter Tilt Angle (Degrees)	58
Front Edge Clearance	5

MT Solar Bill of Materials (1P-0-8TOP-HD-84-L-4Hx3W-953J)

Part	Short Description	BOM Qty
MTS-PC-8	8IN Pole Cap Assembly	1
MTS-HF-HD	H-Frame Assembly-HD	1
MTS-HD-Wing-84	84IN HD Wing	4
MTS-CLAMP-HOOK-4PK	Hook Clamp	3

Rail Bill of Materials

Part	Qty
Rails (208in Long)	6x
Rail Attachment	12x
Module Mid Clamp	18x
Module End Clamp	12x
Ground Lug	3x

Site Details:

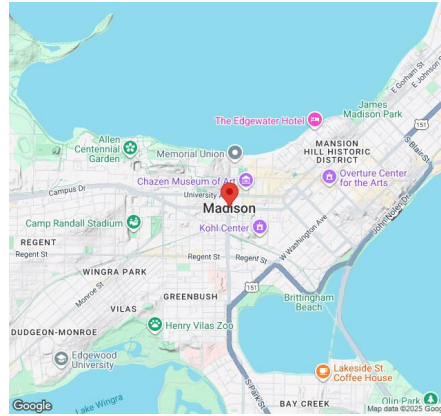

Site Address: Madison, WI, USA

Array Specifications

Duty Classification:	HD
Module Width:	51.40 in
Module Length:	85.60 in
Number of Rows:	4
Number of Columns:	3
Total Number of Modules:	12
Winter Tilt Angle:	58
Front Edge Clearance:	5
Total Array Height at Tilt:	19.67 ft
Total Frame Length:	21.50 ft
Module Info/Notes:	
Array Dimensions N/S:	17.30 ft
Array Dimensions E/W:	21.65 ft
Rail Length:	207.60 in
Rail Spacing:	3.61 ft

Support Specifications

Pole Size:	8in Pipe Sch 80
Pole Length above Grade:	12.34 ft
Number of Poles:	1
Pole Spacing:	0

Foundation Specifications

Foundation Type:	rectangular
Foundation Dimensions:	48x48 in
Foundation Depth (below grade):	8.0 ft
Foundation Volume:	128.00 ft ³

Site Info

Risk Category:	I
Exposure:	C
Soil Classification:	sand
Site Location:	Madison, WI, USA
Wind Speed:	101 mph

Snow Load:

30 psf

Design Disclaimer

This software should be used for preliminary designs and should not be used as a final design unless reviewed, verified and designed by a qualified structural engineer.

AutoDesigner Input

```
{ "wind_speed_override": null, "snow_load_override": null, "direct_snow_load": false, "add_angle_brace": false, "product_type": "Beam", "designer_name": "Aiden", "designer_email": "aiden@mwsolarpower.com", "designer_phone": "", "project_id": "Unleashed", "site_address": "Madison, WI, USA", "module_info": {}, "module_width": 51.4, "module_length": 85.6, "number_rows": 4, "number_columns": 3, "pole_mount_section": "4_40", "core_pipe_width": 65, "core_pipe_section": "2_40", "adjuster_section": "2_40", "core_beam_height": 65, "core_beam_section": "HSS3x2x1/8", "main_pipe_section": "2_12 GA", "pole_spacing": "15", "tilt_angle": 58, "ground_clearance": 5, "risk_category": "I", "exposure_category": "C", "frame_duty_override": "auto", "pole_override": "auto", "soil_type": "sand", "customer_foundation_override": "48_Square", "foundation_type": "Square", "foundation_size": 48, "check_rails": false }
```

Design Notes:

- Deflection checks are set to L/1 due to manufacturer structural design intent
- Foundation Soil Parameters used in this Autodesign are all estimates, proper geotechnical reports are required to confirm soil profiles
- Wind speeds, snow loads and other site specific results are based on ASCE 7-16
- Steel frame design checks are based on AISC 360-16 LRFD
- Design / analysis of fixings and connections are not carried out by this module.
- Impacts of eccentrically applied, partial or pattern loading are not considered by this module.
- Foundation Design and Sizing is approximate only

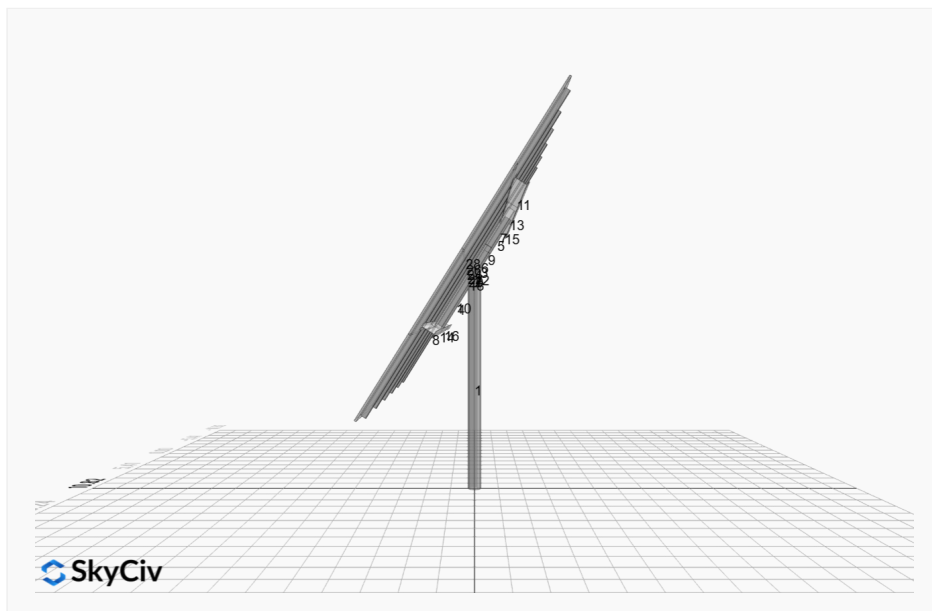
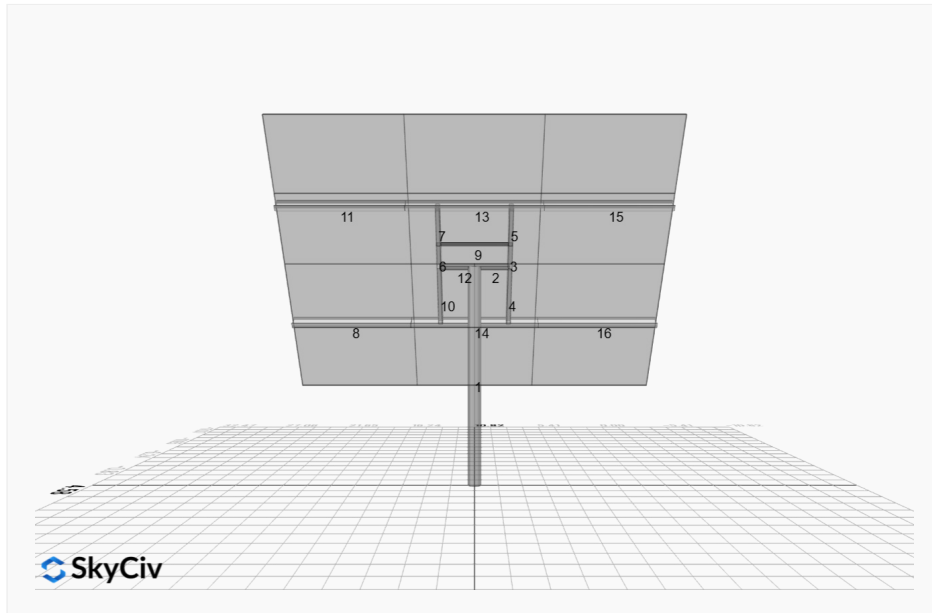

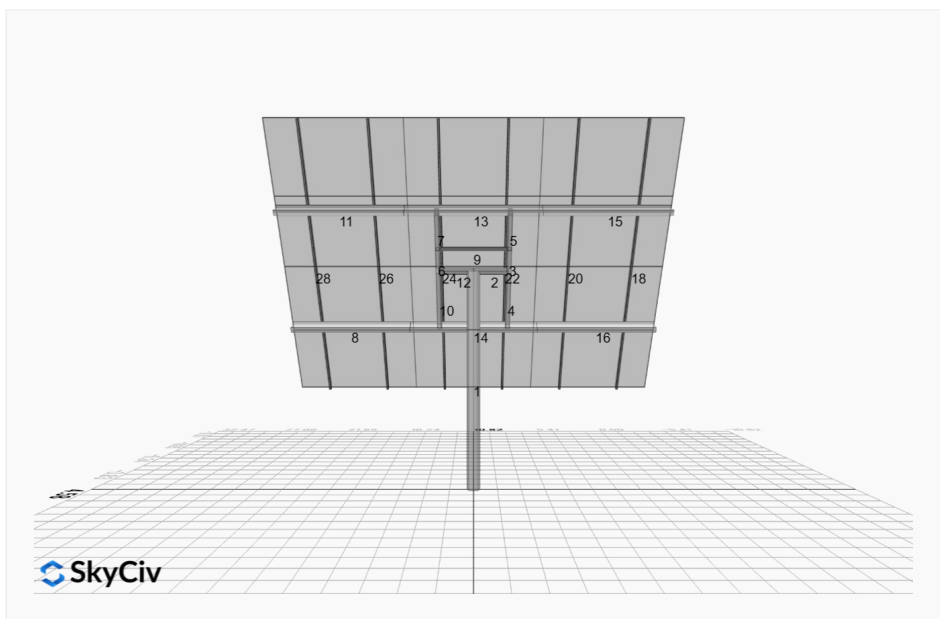
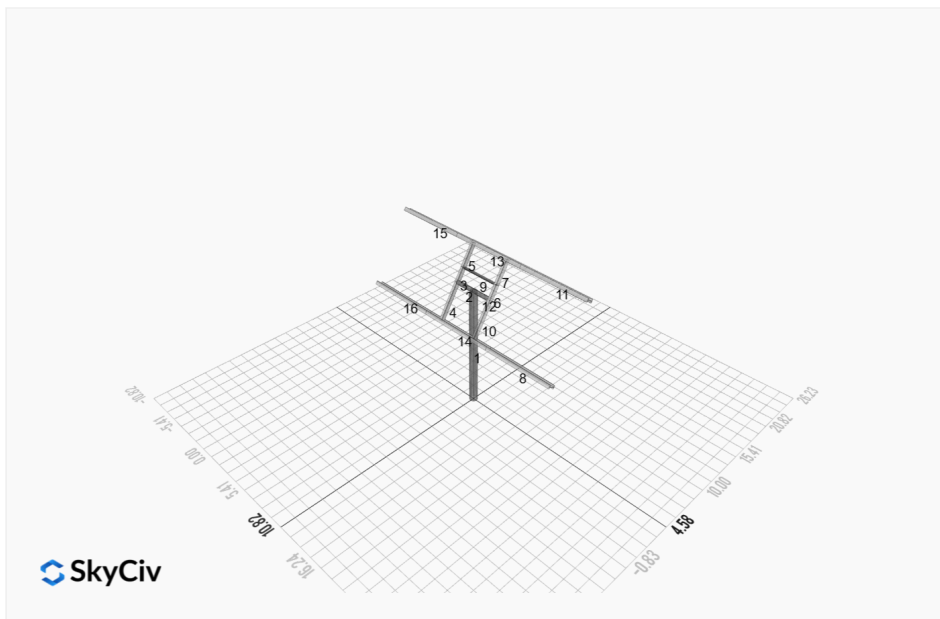
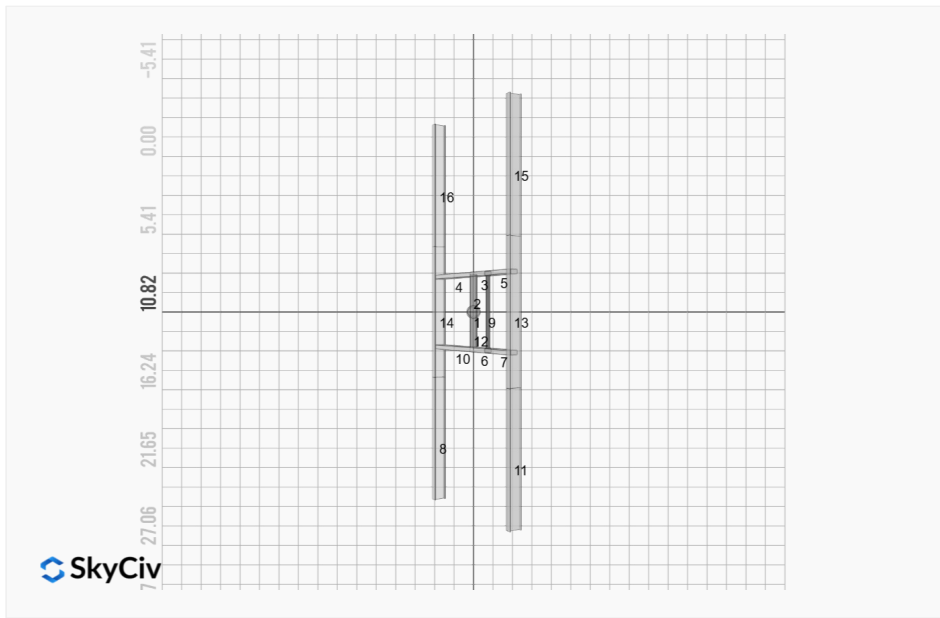

FEM Results (Envelope Worst Case)

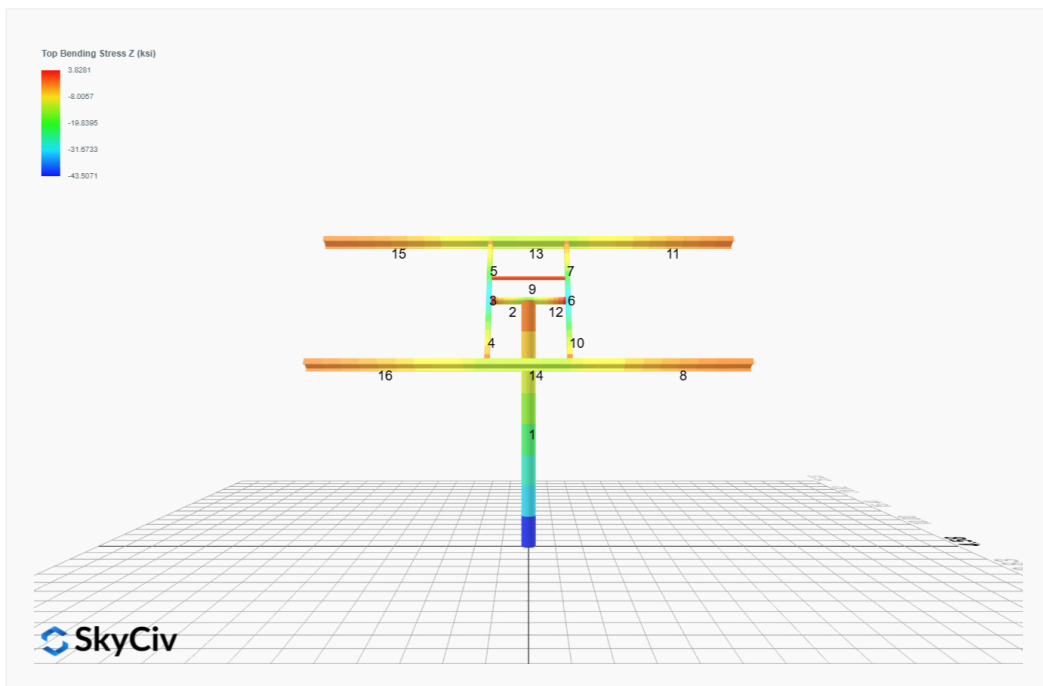
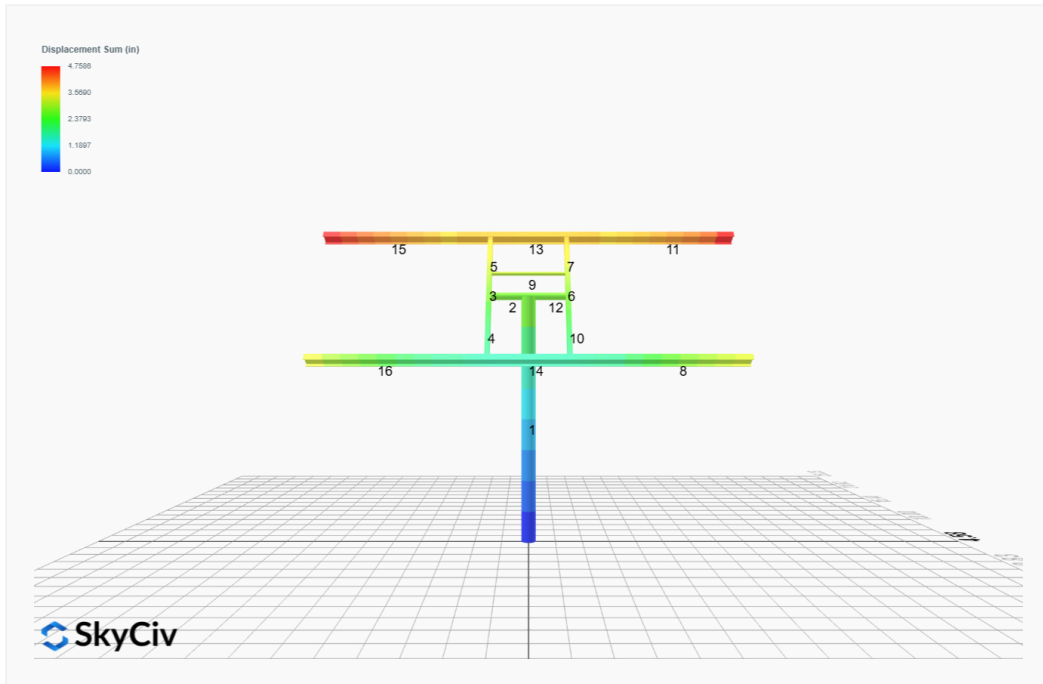

Reaction Forces for Foundation 1 (Node ID#1), (kip, kip-ft)

LRFD Load Combination Results

Name	Fx	Fy	Fz	Mx	My	Mz
ULS: 1. 1.4D	0.0000	3.9860	0.0000	0.0000	-0.0000	0.0321
ULS: 2. 1.2D + 1.6L + 0.5(S or Lr or R)	0.0000	3.8067	0.0000	0.0000	-0.0000	0.0287
ULS: 2. 1.2D + 1.6L + 0.5(S or Lr or R)	0.0000	3.4166	0.0000	0.0000	-0.0000	0.0261
ULS: 3. 1.2D + 1.6(S or Lr or R) + L	0.0000	4.6650	0.0000	0.0000	-0.0000	0.0356
ULS: 5. 1.2D + E + L + 0.2S	0.0000	3.5726	0.0000	0.0000	-0.0000	0.0271
ULS: 7. 0.9D + 1.0E	0.0000	2.5624	0.0000	0.0000	-0.0000	0.0181
ULS: 4. 1.2D + W + L + 0.5(S or Lr or R)_Wind downforce Case A only	-7.0565	8.2161	0.0000	0.0000	0.0000	88.8775
ULS: 4. 1.2D + W + L + 0.5(S or Lr or R)_Wind downforce Case B only	0.0000	3.8067	0.0000	0.0000	-0.0000	0.0287
ULS: 4. 1.2D + W + L + 0.5(S or Lr or R)_Wind uplift Case A only	7.0565	-0.6027	0.0000	-0.0000	-0.0000	-86.9486
ULS: 4. 1.2D + W + L + 0.5(S or Lr or R)_Wind uplift Case B only	0.0000	3.8067	0.0000	0.0000	-0.0000	0.0287
ULS: 4. 1.2D + W + L + 0.5(S or Lr or R)_Wind downforce Case A only	-7.0565	7.8260	0.0000	0.0000	0.0000	88.7827
ULS: 4. 1.2D + W + L + 0.5(S or Lr or R)_Wind downforce Case B only	0.0000	3.4166	0.0000	0.0000	-0.0000	0.0261
ULS: 4. 1.2D + W + L + 0.5(S or Lr or R)_Wind uplift Case A only	7.0565	-0.9928	0.0000	-0.0000	-0.0000	-86.8634
ULS: 4. 1.2D + W + L + 0.5(S or Lr or R)_Wind uplift Case B only	0.0000	3.4166	0.0000	0.0000	-0.0000	0.0261
ULS: 3. 1.2D + 1.6(S or Lr or R) + 0.5W_Wind downforce Case A only	-3.5283	6.8697	0.0000	0.0000	0.0000	44.3222
ULS: 3. 1.2D + 1.6(S or Lr or R) + 0.5W_Wind downforce Case B only	0.0000	4.6650	0.0000	0.0000	-0.0000	0.0356
ULS: 3. 1.2D + 1.6(S or Lr or R) + 0.5W_Wind uplift Case A only	3.5283	2.4603	0.0000	-0.0000	-0.0000	-43.7806
ULS: 3. 1.2D + 1.6(S or Lr or R) + 0.5W_Wind uplift Case B only	0.0000	4.6650	0.0000	0.0000	-0.0000	0.0356
ULS: 3. 1.2D + 1.6(S or Lr or R) + 0.5W_Wind downforce Case A only	-3.5283	5.6213	0.0000	0.0000	0.0000	44.1666
ULS: 3. 1.2D + 1.6(S or Lr or R) + 0.5W_Wind downforce Case B only	0.0000	3.4166	0.0000	0.0000	-0.0000	0.0261
ULS: 3. 1.2D + 1.6(S or Lr or R) + 0.5W_Wind uplift Case A only	3.5283	1.2119	0.0000	-0.0000	-0.0000	-43.6476
ULS: 3. 1.2D + 1.6(S or Lr or R) + 0.5W_Wind uplift Case B only	0.0000	3.4166	0.0000	0.0000	-0.0000	0.0261
ULS: 6. 0.9D + 1.0W_Wind downforce Case A only	-7.0565	6.9719	0.0000	0.0000	0.0000	88.5771
ULS: 6. 0.9D + 1.0W_Wind downforce Case B only	0.0000	2.5624	0.0000	0.0000	-0.0000	0.0181
ULS: 6. 0.9D + 1.0W_Wind uplift Case A only	7.0565	-1.8470	0.0000	-0.0000	-0.0000	-86.6835
ULS: 6. 0.9D + 1.0W_Wind uplift Case B only	0.0000	2.5624	0.0000	0.0000	-0.0000	0.0181

ASD Load Combination Results

Name	Fx	Fy	Fz	Mx	My	Mz
ULS: 1. D	0.0000	2.8472	0.0000	0.0000	-0.0000	0.0207
ULS: 2. D + L	0.0000	2.8472	0.0000	0.0000	-0.0000	0.0207
ULS: 3. D + (S or Lr or R)	0.0000	3.6274	0.0000	0.0000	-0.0000	0.0253
ULS: 3. D + (S or Lr or R)	0.0000	2.8472	0.0000	0.0000	-0.0000	0.0207
ULS: 4. D + 0.75L + 0.75(S or Lr or R)	0.0000	3.4324	0.0000	0.0000	-0.0000	0.0240
ULS: 4. D + 0.75L + 0.75(S or Lr or R)	0.0000	2.8472	0.0000	0.0000	-0.0000	0.0207
ULS: 5b. D + 0.7E	0.0000	2.8472	0.0000	0.0000	-0.0000	0.0207
ULS: 6b. D + 0.75L + 0.75(0.7)E + 0.75S	0.0000	3.4324	0.0000	0.0000	-0.0000	0.0240
ULS: 8. 0.6D + 0.7E	0.0000	1.7083	0.0000	0.0000	-0.0000	0.0111
ULS: 5a. D + 0.6W_Wind downforce Case A only	-4.2339	5.4928	0.0000	0.0000	0.0000	52.9677
ULS: 5a. D + 0.6W_Wind downforce Case B only	0.0000	2.8472	0.0000	0.0000	-0.0000	0.0207
ULS: 5a. D + 0.6W_Wind uplift Case A only	4.2339	0.2015	0.0000	-0.0000	-0.0000	-52.2566
ULS: 5a. D + 0.6W_Wind uplift Case B only	0.0000	2.8472	0.0000	0.0000	-0.0000	0.0207
ULS: 6a. D + 0.75L + 0.75(0.6)W + 0.75(S or Lr or R)_Wind downforce Case A only	-3.1754	5.4166	0.0000	0.0000	0.0000	39.7319
ULS: 6a. D + 0.75L + 0.75(0.6)W + 0.75(S or Lr or R)_Wind downforce Case B only	0.0000	3.4324	0.0000	0.0000	-0.0000	0.0240
ULS: 6a. D + 0.75L + 0.75(0.6)W + 0.75(S or Lr or R)_Wind uplift Case A only	3.1754	1.4481	0.0000	-0.0000	-0.0000	-39.3057
ULS: 6a. D + 0.75L + 0.75(0.6)W + 0.75(S or Lr or R)_Wind uplift Case B only	0.0000	3.4324	0.0000	0.0000	-0.0000	0.0240

Name	Fx	Fy	Fz	Mx	My	Mz
ULS: 6a. D + 0.75L + 0.75(0.6)W + 0.75(S or Lr or R)_Wind downforce Case A only	-3.1754	4.8314	0.0000	0.0000	0.0000	39.6673
ULS: 6a. D + 0.75L + 0.75(0.6)W + 0.75(S or Lr or R)_Wind downforce Case B only	0.0000	2.8472	0.0000	0.0000	-0.0000	0.0207
ULS: 6a. D + 0.75L + 0.75(0.6)W + 0.75(S or Lr or R)_Wind uplift Case A only	3.1754	0.8629	0.0000	-0.0000	-0.0000	-39.2492
ULS: 6a. D + 0.75L + 0.75(0.6)W + 0.75(S or Lr or R)_Wind uplift Case B only	0.0000	2.8472	0.0000	0.0000	-0.0000	0.0207
ULS: 7. 0.6D + 0.6W_Wind downforce Case A only	-4.2339	4.3539	0.0000	0.0000	0.0000	52.8023
ULS: 7. 0.6D + 0.6W_Wind downforce Case B only	0.0000	1.7083	0.0000	0.0000	-0.0000	0.0111
ULS: 7. 0.6D + 0.6W_Wind uplift Case A only	4.2339	-0.9373	0.0000	-0.0000	-0.0000	-52.1150
ULS: 7. 0.6D + 0.6W_Wind uplift Case B only	0.0000	1.7083	0.0000	0.0000	-0.0000	0.0111

Worst Case Reactions (LRFD)

Note: Downforce / downwind wind load cases are assumed to govern.

Result	Value (kip, kip-ft)
Axial	8.2161
Shear X	-7.0565
Shear Z	0.0000
Moment X	0.0000
Moment Y (Twist)	0.0000
Moment Z	88.8775

Worst Case Reactions (ASD)

Note: Downforce / downwind wind load cases are assumed to govern.

Result	Value (kip, kip-ft)
Axial	5.4928
Shear X	-4.2339
Shear Z	0.0000
Moment X	0.0000
Moment Y (Twist)	0.0000
Moment Z	52.9677

Project Details

Design Code: AISC 360-16 LRFD
 Provision: LRFD
 Country: United States
 User Name: sales@mtsolar.us
 Unit System: imperial



Design Input Information

Design Factors			
Φ_t	Φ_c	Φ_b	Φ_v
0.9	0.9	0.9	0.9

Design Materials			
ID	E (ksi)	F_y (ksi)	F_u (ksi)
1	29000	50	65

Section Dimensions

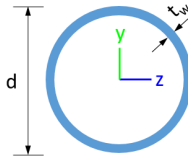

ID	Name	d (in)	t_w (in)				
2	2in Pipe Sch 80	2.38	0.22				
5	4in Pipe Sch 80	4.50	0.34				
10	8in Pipe Sch 80	8.63	0.50				

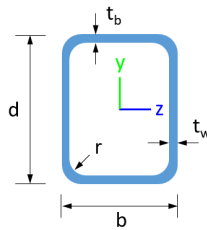

ID	Name	d (in)	b (in)	t_w (in)	t_b (in)	r (in)	
16	HSS5x3x3/16	5.00	3.00	0.17	0.17	0.17	

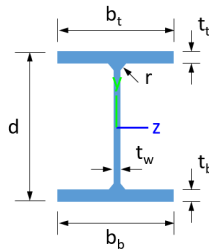

ID	Name	d (in)	t_w (in)	b_t (in)	b_b (in)	t_t (in)	t_b (in)	r (in)
19	W8x10	7.89	0.17	3.94	3.94	0.20	0.20	0.30

Section Properties

ID	Name	A (in ²)	J (in ⁴)	I_{yp} (in ⁴)	I_{zp} (in ⁴)	I_w (in ⁶)	S_{yp} (in ³)	S_{zp} (in ³)
----	------	----------------------	----------------------	-----------------------------	-----------------------------	--------------------------	-----------------------------	-----------------------------

3	116.10	115.41	15.79	11.10	42.08	23.28
4	116.10	111.33	15.79	11.10	42.08	23.28
5	116.10	114.23	15.79	11.10	42.08	23.28
6	116.10	115.41	15.79	11.10	42.08	23.28
7	116.10	114.23	15.79	11.10	42.08	23.28
8	133.20	15.17	32.87	6.12	40.24	43.62
9	66.48	58.89	3.82	3.82	19.94	19.94
10	116.10	111.33	15.79	11.10	42.08	23.28
11	133.20	15.17	32.87	6.12	40.24	43.62
12	198.33	196.72	21.95	21.95	59.50	59.50
13	133.20	85.85	23.30	6.12	40.24	43.62
14	133.20	85.85	23.29	6.12	40.24	43.62
15	133.20	15.17	32.87	6.12	40.24	43.62
16	133.20	15.17	32.87	6.12	40.24	43.62

Design Ratio

Member ID	P	M _z	M _y	V _y	V _z	(P,M _z ,M _y)	Worst LC	KL/r	δ	Status
1	0.016	0.717	0.000	0.041	0.000	0.725	#13	0.167	Not Required	Pass
2	0.006	0.281	0.319	0.064	0.059	0.603	#13	0.035	Not Required	Pass
3	0.007	0.594	0.053	0.059	0.012	0.612	#13	0.045	Not Required	Pass
4	0.007	0.591	0.199	0.059	0.040	0.681	#13	0.080	Not Required	Pass
5	0.007	0.369	0.208	0.059	0.054	0.415	#13	0.074	Not Required	Pass
6	0.007	0.594	0.053	0.059	0.012	0.612	#13	0.045	Not Required	Pass
7	0.007	0.369	0.208	0.059	0.054	0.415	#13	0.074	Not Required	Pass
8	0.000	0.171	0.298	0.040	0.012	0.404	#21	Not Required	Not Required	Pass
9	0.026	0.036	0.071	0.001	0.000	0.115	#13	0.204	Not Required	Pass
10	0.007	0.591	0.199	0.059	0.040	0.681	#13	0.080	Not Required	Pass
11	0.000	0.171	0.298	0.040	0.012	0.404	#21	Not Required	Not Required	Pass
12	0.006	0.281	0.319	0.064	0.059	0.603	#13	0.035	Not Required	Pass
13	0.009	0.384	0.465	0.050	0.015	0.736	#13	0.190	Not Required	Pass
14	0.011	0.389	0.465	0.050	0.015	0.736	#13	0.190	Not Required	Pass
15	0.000	0.171	0.298	0.040	0.012	0.404	#21	Not Required	Not Required	Pass
16	0.000	0.171	0.298	0.040	0.012	0.404	#21	Not Required	Not Required	Pass

Definitions

Φ _t	Safety factor for tensile
Φ _c	Safety factor for compression
Φ _b	Safety factor for flexure
Φ _v	Safety factor for shear
E	Modulus of elasticity
F _y	Specified minimum yield stress
F _u	Specified minimum tensile strength
A	Cross-sectional area
J	Torsional constant
I _{yp}	Moment of inertia about the Y axes
I _{zp}	Moment of inertia about the Z axes
I _w	Warping constant
S _{yp}	Plastic section modulus about the Y axis
S _{zp}	Plastic section modulus about the Z axis
KL	Effective length
C _b	Buckling modification factor (from all load combinations)
L _b	Length between braced points
LST	Limited slenderness for tension
LSC	Limited slenderness for compression

LD	Limited deflection
P_n	Nominal axial strength (tension/compression)
M_n	Nominal flexural strength (about Z/Y axis)
V_n	Nominal shear strength (along Z/Y axis)
P	Design ratio in case of axial force
M_z	Design ratio in case of bending about Z axis
M_y	Design ratio in case of bending about Y axis
V_y	Design ratio in case of shear along Y axis
V_z	Design ratio in case of shear along Z axis
(P, M_z, M_y)	Design ratio in case of axial force and bending action
KL/r	Design ratio in case of section slenderness
δ	Design ratio in case of member deflection
OK	Capacity is provided
NG	Capacity is not provided

IBC 2018 Pile Design



Input	Description
Region	American Standard
Concrete design code	American Concrete Institute (ACI 318:2019)

Cross-section

Input	Description	Value
Shape	Cross-sectional shape	Square
b	Section width	48 in
D	Section depth	48 in

Material Properties

Input	Description	Value
f'_{ck}	Concrete compressive strength	2.5 ksi
f_{yk}	Yield strength of steel	60 ksi
d_b	Rebar diameter	#5 (0.625) in
cover	Concrete cover	3 in

Soil Parameters (IBC 1806)

Input	Description	Value
Soil type	Sand, silty sand, clayey sand, silty gravel & clayey gravel	
q_a	Allowable bearing pressure	2000 psf
R	Allowable lateral pressure	150 psf/ft

Loading

Load	ASD	LRFD
P	5.493 kip	8.216 kip
V _x	-4.234 kip	-7.057 kip
V _z	0 kip	0 kip
M _x	0 kip-ft	0 kip-ft
M _z	52.97 kip-ft	88.88 kip-ft

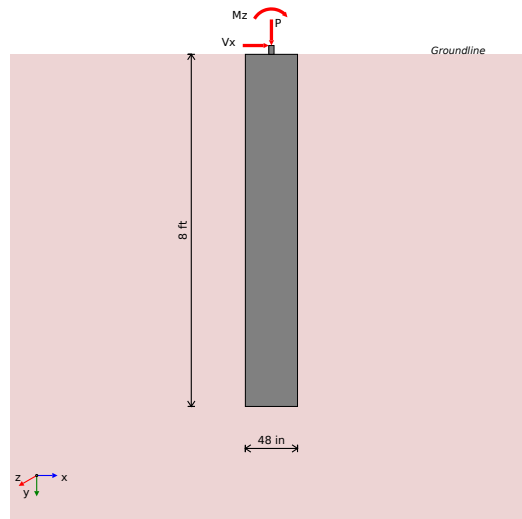

Required depth to resist lateral loads (ASD)

Allowable lateral pressure

$$R = 150 \text{ psf/ft}$$

Point of application of lateral load:

$$H = h_1 + h_2 + h_e = 0 + 0 + 0 = 0 \text{ ft}$$

Considering x-direction:

Lateral force per section length

$$H_o = \frac{V_x}{1.57 \times D} = \frac{-4.234}{1.57 \times 48} = -0.674 \frac{\text{kip}}{\text{ft}}$$

Moment per section length

$$M_o = \frac{M_z + (V_z \times H)}{1.57 \times D} = \frac{52.97 + (-4.234 \times 0)}{1.57 \times 48} = 8.434 \frac{\text{kip-ft}}{\text{ft}}$$

Required depth of embedment in earth:

$$L_e^3 - \left(9 \times \frac{H_o \times L_z}{R}\right) - \left(12 \times \frac{M_o}{R}\right) = 0$$

Solving the cubic equation:

$$L_{e,z} = 7.252 \text{ ft}$$

Considering z-direction:

Since there are no loads applied in this direction, the required effective length: $L_{e,z} = 0 \text{ ft}$.

Minimum embedded depth

Depth of pile required

$$L_{e,req} = \text{MAX}[L_{e,x}, L_{e,z}] = \text{MAX}[7.252, 0] = 7.252 \text{ ft}$$

Actual embedded length

$$L_e = L - h_2 - h_e = 8 - 0 - 0 = 8 \text{ ft}$$

Utilisation

$$\text{Ratio} = \frac{L_{e,req}}{L_e} = \frac{7.252}{8} = 0.907$$

UTILITY: 0.91

REFERENCES

CALCULATIONS

RESULTS

End-bearing Capacity (ASD)

Allowable bearing pressure
Unit weight of concrete

$q_a = 2000 \text{ psf}$
 $w_c = 0.15 \text{ kip/ft}^3$

Cross-sectional area:

$$A = b \times D = 48 \times 48 = 16 \text{ ft}^2$$

End-bearing pressure:

$$q = \frac{P}{A} = \frac{5.493}{16} = 343.3 \text{ psf}$$

Utilisation

$$\text{Ratio} = \frac{q}{q_a} = \frac{343.3}{2000} = 0.172$$

UTILITY: 0.17

Lateral Soil Pressure (ASD)

Allowable lateral pressure

$R = 150 \text{ psf/ft}$

Length to least lateral dimension ratio:

$$\frac{L}{\text{MIN}[b, D]} = \frac{8}{\text{MIN}[4, 4]} = 2$$

L/D ratio ≤ 10 . This pile is classified as a short pile.

Considering x-direction:

Distance from resting surface to pivot point:

$$a = \frac{(4 \times M_o \times L_e) + (3 \times H_o \times L_e^2)}{(6 \times M_o) + (4 \times H_o \times L_e)}$$

$$a = \frac{(4 \times 8.434 \times 8) + (3 \times 0.674 \times 8^2)}{(6 \times 8.434) + (4 \times 0.674 \times 8)} = 5.533 \text{ ft}$$

Earth pressure against the pile at a distance a/2 from the resting surface:

$$p = \frac{0.75 \times [(4 \times M_o) + (3 \times H_o \times L_e)]^2}{L_e^2 \times [(3 \times M_o) + (2 \times H_o \times L_e)]}$$

$$p = \frac{0.75 \times [(4 \times 8.434) + (3 \times -0.674 \times 8)]^2}{8^2 \times [(3 \times 8.434) + (2 \times -0.674 \times 8)]} = 0.249 \frac{\text{kip}}{\text{ft}^2}$$

Allowable lateral soil pressure at a depth of a/2:

$$p_a = R \times \frac{a}{2} = 0.15 \times \frac{5.533}{2} = 0.415 \frac{\text{kip}}{\text{ft}^2}$$

Utilisation - pressure at a depth of a/2

$$\text{Ratio} = \frac{p}{p_a} = \frac{0.249}{0.415} = 0.6$$

UTILITY: 0.60

Earth pressure against the pile at distance L_e :

$$s = \frac{6 \times [(2 \times M_o) + (H_o \times L_e)]}{L_e^2} = \frac{6 \times [(2 \times 8.434) + (-0.674 \times 8)]}{8^2} = 1.076 \frac{\text{kip}}{\text{ft}^2}$$

Allowable lateral soil pressure at a depth of L_e :

$$p_s = R \times L_e = 0.15 \times 8 = 1.2 \frac{\text{kip}}{\text{ft}^2}$$

Utilisation - pressure at a depth of L_e

$$\text{Ratio} = \frac{s}{p_s} = \frac{1.076}{1.2} = 0.896$$

UTILITY: 0.90

Considering z-direction:

Since no loads are applied in this direction, lateral soil pressure check is not required.

REFERENCES

CALCULATIONS

RESULTS

Shear force and bending moment (LRFD)

Considering x-direction:

Lateral force per section length

$$H_o = \frac{V_x}{1.57 \times D} = \frac{-7.057}{1.57 \times 48} = -1.124 \frac{\text{kip}}{\text{ft}}$$

Moment per section length

$$M_o = \frac{M_z + (V_x \times H)}{1.57 \times D} = \frac{88.88 + (-7.057 \times 0)}{1.57 \times 48} = 14.15 \frac{\text{kip-ft}}{\text{ft}}$$

Distance from resting surface to pivot point:

$$a = \frac{(4 \times M_o \times L_e) + (3 \times H_o \times L_e^2)}{(6 \times M_o) + (4 \times H_o \times L_e)}$$

$$a = \frac{(4 \times 14.15 \times 8) + (3 \times 1.124 \times 8^2)}{(6 \times 14.15) + (4 \times 1.124 \times 8)} = 5.532 \text{ ft}$$

Max shear force located at depth a:

$$E = \frac{M_o}{H_o} = \frac{14.15}{-1.124} = 12.6 \text{ ft}$$

$$V_{max,x} = (H_o \times D) \times [1 - 3 \times \left(\frac{4 \times E}{L_e} + 3\right) \times \left(\frac{a}{L_e}\right)^2] + [4 \times \left(\frac{3 \times E}{L_e} + 2\right) \times \left(\frac{a}{L_e}\right)^3]$$

$$V_{max,x} = (-1.124 \times 48) \times [1 - 3 \times \left(\frac{4 \times 12.6}{8} + 3\right) \times \left(\frac{5.532}{8}\right)^2] + [4 \times \left(\frac{3 \times 12.6}{8} + 2\right) \times \left(\frac{5.532}{8}\right)^3]$$

$$V_{max,x} = 15.49 \text{ kip}$$

Max bending moment located at a depth of a/2:

$$M_{max,x} = (H_o \times D \times L_e) \times \left[\left(\frac{E}{L_e} + \frac{a}{2 \times L_e}\right) - \left[\left(\frac{4 \times E}{L_e} + 3\right) \times \left(\frac{a}{2 \times L_e}\right)^3\right] + \left[\left(\frac{3 \times E}{L_e} + 2\right) \times \left(\frac{a}{2 \times L_e}\right)^4\right]\right]$$

$$M_{max,x} = (-1.124 \times 48 \times 8) \times \left[\left(\frac{12.6}{8} + \frac{5.532}{2 \times 8}\right) - \left[\left(\frac{4 \times 12.6}{8} + 3\right) \times \left(\frac{5.532}{2 \times 8}\right)^3\right] + \left[\left(\frac{3 \times 12.6}{8} + 2\right) \times \left(\frac{5.532}{2 \times 8}\right)^4\right]\right]$$

$$M_{max,x} = 58.68 \text{ kip-ft}$$

Considering z-direction:

There are no loads applied in this direction.

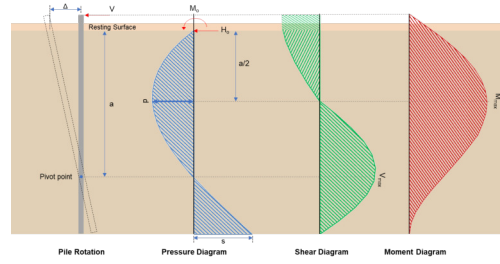

Minimum Reinforcement Check (LRFD)

Gross area of concrete:

$$A_g = b \times D = 48 \times 48 = 2304 \text{ in}^2$$

Main Reinforcement

22.4.2.2 Required reinforcement:

$$A_{st,req} = \frac{P - (0.85 \times f'_{ck} \times A_g)}{f_{yk} - (0.85 \times f'_{ck})} = \frac{8.216 - (0.85 \times 2.5 \times 2304)}{60 - (0.85 \times 2.5)} = -84.45 \text{ in}^2$$

10.6.1.1 Maximum reinforcement:

$$A_{st,max} = 0.08 \times A_g = 0.08 \times 2304 = 184.3 \text{ in}^2$$

7.6.1.1 Minimum reinforcement:

$$A_{st,min} = 0.0018 \times A_g = 0.0018 \times 2304 = 4.147 \text{ in}^2$$

Governing minimum reinforcement area:

$$(0.0018 \times A_g) \leq A_{st,req} \leq (0.08 \times A_g)$$

$$A_{min} = 4.147 \text{ in}^2$$

Minimum number of reinforcements:

$$A_{bar} = 0.307 \text{ in}^2$$

$$n_{min} = \frac{A_{min}}{A_{bar}} = \frac{4.147}{0.307} = 14$$

25.2.3 Minimum spacing:

$$s_{rebar} = \text{MAX}[1.5, 1.5 \times d_b] = \text{MAX}[1.5, (1.5 \times 0.625)] = 1.5 \text{ in}$$

Use: $n = 16$ pcs at 1.5 in minimum spacing

Total reinforcement area:

$$A_{st} = 16 \times 0.307 = 4.909 \text{ in}^2$$

Shear Reinforcement

25.7.2.2 For main reinforcement ≤ 1.41 in: Use #3(0.375 in)

Maximum spacing of shear Reinforcements:

$$s = \text{MIN}[16 \times d_b, 48 \times d_{b,ires}, \text{MIN}(b, D)] = \text{MIN}[(16 \times 0.625), (48 \times 0.375), \text{MIN}(48, 48)] = 10 \text{ in}$$

Detailing Summary

Detailing Summary	
Main reinforcement	#5 (0.625 in) - 16pcs at 1.5 in min. spacing
Shear reinforcement	#3 (0.375 in) at 10 in max. spacing

Axial Compression Strength (LRFD)

22.4.2.2 Allowable axial compressive strength:

$$\phi P_N = \phi \times 0.8 \times [(0.85 \times f'_{ck} \times (A_g - A_{st})) + (f_{yk} \times A_{st})]$$

$$\phi P_N = 0.65 \times 0.8 \times [(0.85 \times 2.5 \times (2304 - 4.909)) + (60 \times 4.909)] = 2694 \text{ kip}$$

Utilisation

$$\text{Ratio} = \frac{P}{\phi P_N} = \frac{8.216}{2694} = 0.003$$

Shear Strength LRFD

Effective shear width	$b_w = 48$ in
Effective shear depth	$d = 44.31$ in
Shear reinforcement area	$A_v = 0.221$ in ²
Shear reinforcement spacing	$s = 10$ in
Concrete type factor (Normal concrete)	$\lambda = 1$
Strength reduction factor for shear	$\phi = 0.75$
Maximum shear in the x-direction	$V_{max,x} = 15.49$ kip
Maximum shear in the z-direction	$V_{max,z} = 0$ kip

22.5.5.1.1 Max shear strength of concrete:

$$V_{c,max} = 5 \times \lambda \times \sqrt{f'_{ck}} \times b_w \times d = 5 \times 1 \times \sqrt{2.5} \times 48 \times 44.31 = 531.8 \text{ kip}$$

Table 22.5.5.1 Shear strength of concrete:

$$V_{c,a} = \left(2 \times \lambda \times \sqrt{f'_{ck}} + \text{MIN} \left[\frac{P}{6 \times A_g}, (0.05 \times f'_{ck}) \right] \right) \times (b_w \times d)$$

$$V_{c,a} = \left(2 \times 1 \times \sqrt{2.5} + \text{MIN} \left[\frac{8.216}{6 \times 2304}, (0.05 \times 2.5) \right] \right) \times (48 \times 44.31) = 214 \text{ kip}$$

Governing shear strength of concrete:

$$V_c = \text{MIN}[V_{c,max}, V_{c,a}] = \text{MIN}[531.8, 214] = 214 \text{ kip}$$

22.5.1.2 Shear strength of steel (a):

$$V_{s,a} = 8 \times \sqrt{f'_{ck}} \times b_w \times d = 8 \times \sqrt{2.5} \times 48 \times 44.31 = 850.8 \text{ kip}$$

22.5.8.5.3 Shear strength of steel (b):

$$V_{s,b} = \frac{A_v \times f_{yk} \times d}{s} = \frac{0.221 \times 60 \times 44.31}{10} = 58.73 \text{ kip}$$

Governing shear strength of steel:

$$V_s = \text{MIN}[V_{s,a}, V_{s,b}] = \text{MIN}[850.8, 58.73] = 58.73 \text{ kip}$$

22.5.1.1 Allowable shear strength:

$$\phi V_n = \phi \times (V_c + V_s) = 0.75 \times (214 + 58.73) = 204.5 \text{ kip}$$

$$V_{max} = \text{MAX}[15.49, 0] = 15.49 \text{ kip}$$

Utilisation

$$\text{Ratio} = \frac{V_{max}}{\phi V_n} = \frac{15.49}{204.5} = 0.076$$

Flexural Strength (LRFD)

Concrete type factor (Normal concrete)	$\lambda = 1$
Strength reduction factor for flexure	$\phi = 0.65$
Modulus of steel reinforcement	$E_s = 200e3$ ksi
Maximum concrete strain	$\epsilon_c = 0.0030$
Yield strain of steel f_y/E_s	$\epsilon_{y1} = 0.0003$
Section width	$b = 48$ in
Distance to the compression rebar	$d_c = 3.688$ in
Distance to the tension rebar	$d = 44.31$ in
Total bar area	$A_s = 4.909$ in ²
Maximum applied axial load	$P = 8.216$ kip
Maximum moment in the x-direction	$M_{max,x} = 58.68$ kip-ft
Maximum moment in the z-direction	$M_{max,z} = 0$ kip-ft

Compressive force due to concrete:

$$\beta_1 = 0.85$$

$$C_{rc} = 0.85 \times \beta_1 \times f'_c \times b \times c$$

Compressive force due to bars in compression:

$$C_{rs} = f_1 \times A_{sc}$$

$$\epsilon_1 = (c - d_s) \times \frac{\epsilon_c}{c}$$

$$f_1 = E_s \times \epsilon_1 \quad (\epsilon_1 < \epsilon_{sy}), f_1 = f_y \quad (\epsilon_1 \geq \epsilon_{sy})$$

Tensile force due to bars in tension:

$$T_{rs} = f_2 \times A_{st}$$

$$\epsilon_2 = (d - c) \times \frac{\epsilon_{cu}}{c}$$

$$f_2 = E_s \times \epsilon_2 \quad (\epsilon_2 < \epsilon_{sy}), f_2 = \phi_s \times f_y \quad (\epsilon_2 \geq \epsilon_{sy})$$

Interaction Diagram Summary

Point	Case	M _r	P _r
P1	Pure Tension	0	-265.1
P2	Pure Bending	498.4	0
P3	Balanced Failure	1303	2402
P4	Decompression	1077	2629
P5	Compression Limit	982	2694
P6	Pure Compression	0	2694

Uniaxial Bending Check

$$M_f = \text{MAX}[58.68, 0] = 58.68 \text{ kip-ft}$$

Interaction Diagram

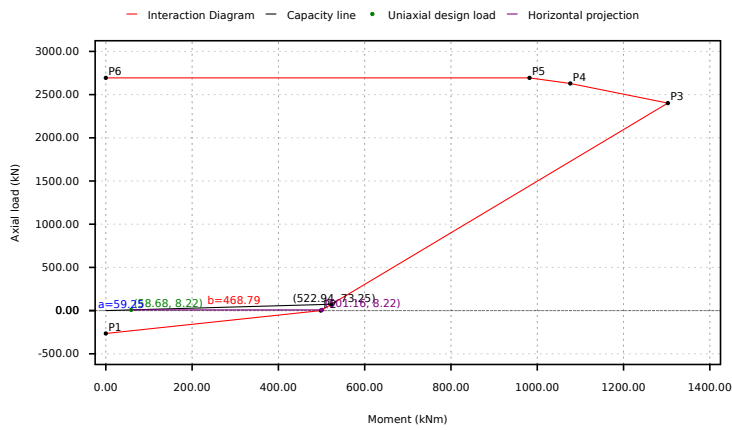

Segment	Signed Distance
P1 - P2	213.7
P2 - P3	419.6
P3 - P4	2570
P4 - P5	2737
P5 - P6	2685
Status	PASS: Point lies inside the curve

Utilisation

$$\text{Ratio} = \frac{a}{a+b} = \frac{59.25}{59.25 + 468.8} = 0.112$$

UTILITY: 0.11

REFERENCES

CALCULATIONS

RESULTS

Results Summary

Result Name	Results
PILE DETAILS	
Length of the pile	8.00 ft
Dimensions	48 x 48 in
Main bar reinforcement	#5-16pcs at 1.5 in min.
Shear reinforcement	#3 at 10 in max.
UTILISATIONS	
Required depth	0.91
End-bearing capacity	0.17
P _a	0.60
P _s	0.90
Axial compression strength	0.00
Shear strength	0.08
Uniaxial bending strength	0.11

