

# Your Project Calculations



Project Name: MTSOLAR\_6GEEK5LB82F5-RevA

S3D Model Link:  
[https://platform.skyciv.com/structural?preload\\_name=MTSOLAR\\_6GEEK5LB82F5-RevA&preload\\_path=Shared%20Enterprise%20Folder/MT\\_Solar\\_Projects/6\\_2023](https://platform.skyciv.com/structural?preload_name=MTSOLAR_6GEEK5LB82F5-RevA&preload_path=Shared%20Enterprise%20Folder/MT_Solar_Projects/6_2023)

Public Model Link:  
[https://platform.skyciv.com/structural-viewer?project\\_id=G8UPamgFcWD1fn3Xia3A55v6GoeY0kONMKRk0xmeMMUrPO20L7gZ0w2EBwBjgbsl](https://platform.skyciv.com/structural-viewer?project_id=G8UPamgFcWD1fn3Xia3A55v6GoeY0kONMKRk0xmeMMUrPO20L7gZ0w2EBwBjgbsl)

## Array Specification

Product:	Beam
Unique ID:	3P-17-10TOP-XD-45-L-5Hx8W-9J0E
Duty Classification:	XD
Module Width:	39.00 in
Module Length:	75.00in
Number of Rows:	5
Number of Columns:	8
Total Number of Modules:	40
Desired Tilt Angle:	55
Front Edge Clearance:	10
Total Array Height at Tilt:	23.40 ft
Total Frame Length:	49.00 ft
Frame Weight:	4028 lbs
Array Dimensions N/S:	16.46 ft
Array Dimensions E/W:	50.67 ft
Rail Length:	197.50 in
Rail Spacing:	3.13 ft
Rail Check:	Not Checked

## Support Specifications

Pole Size:	10in Pipe Sch 40
Pole Length above Grade:	16.74 ft
Number of Poles:	3
Pole Spacing:	17 ft

## Foundation Specifications

Foundation Type:	Square
Foundation Dimensions:	48 x 48 in
Foundation Depth (below grade):	Pile 1: 7.75 ft Pile 2: 7.75 ft Pile 3: 7.75 ft
Foundation Volume:	13.778 y <sup>3</sup>
Foundation Result:	PASSED
Mount Twist:	0.357497 kip

## Site Info

Risk Category:	I
Exposure:	B
Soil Classification:	sand
Site Location:	22222 NV-431, Reno, NV 89511, USA
Wind Speed:	120 mph
Snow Load:	243 psf
Design Uplift Pressure:	0.019019 ksf
Design Downforce Pressure:	-0.019019 ksf
Design Snow Pressure:	0.040082 ksf



### Design Disclaimer

This software should be used for preliminary designs and should not be used as a final design unless reviewed, verified and designed by a qualified structural engineer.

### AutoDesigner Input

```
{
  "wind_speed_override": 120,
  "snow_load_override": 243,
  "direct_snow_load": false,
  "product_type": "Beam",
  "project_id": "MTSOLAR_6GEEK5L B82F5-RevA",
  "site_address": "22222 NV-431, Reno, NV 89511, USA",
  "module_width": 39,
  "module_length": 75,
  "number_rows": 5,
  "number_columns": 8,
  "pole_mount_section": "4_40",
  "core_pipe_width": 65,
  "core_pipe_section": "2_40",
  "adjuster_section": "2_40",
  "core_beam_height": 65,
  "core_beam_section": "HSS3x2x1/8",
  "main_pipe_section": "2_12GA",
  "pole_spacing": 15,
  "tilt_angle": 55,
  "ground_clearance": 10,
  "risk_category": "I",
  "exposure_category": "B",
  "frame_duty_override": "XD",
  "pole_override": "10_40",
  "soil_type": "sand",
  "foundation_type": "Square",
  "foundation_size": 48,
  "check_rails": false
}
```

### Design Notes:

- AISC Deflection checks are set to L/1 due to structure design intent

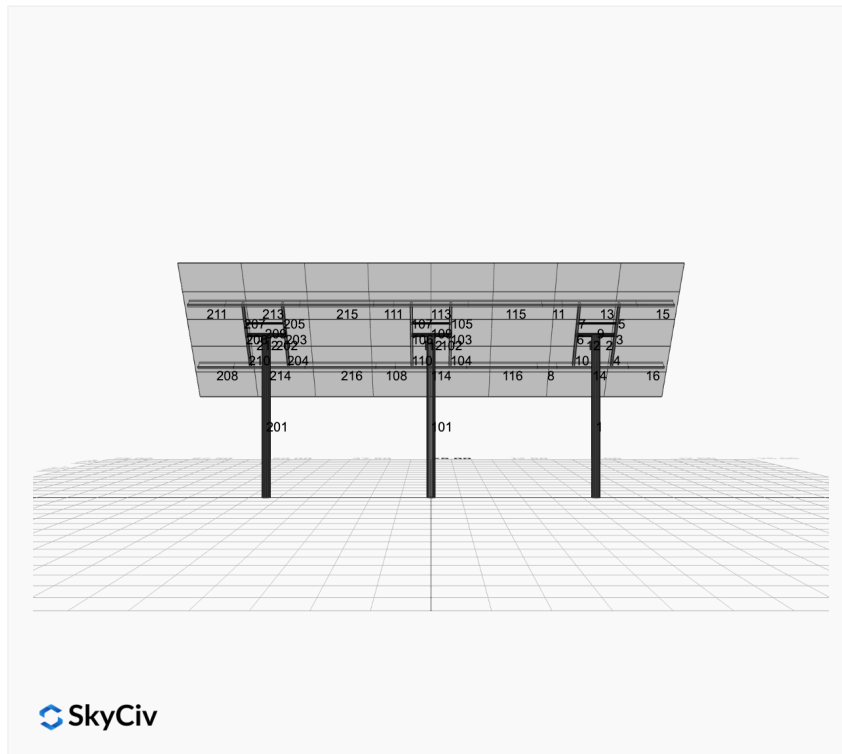

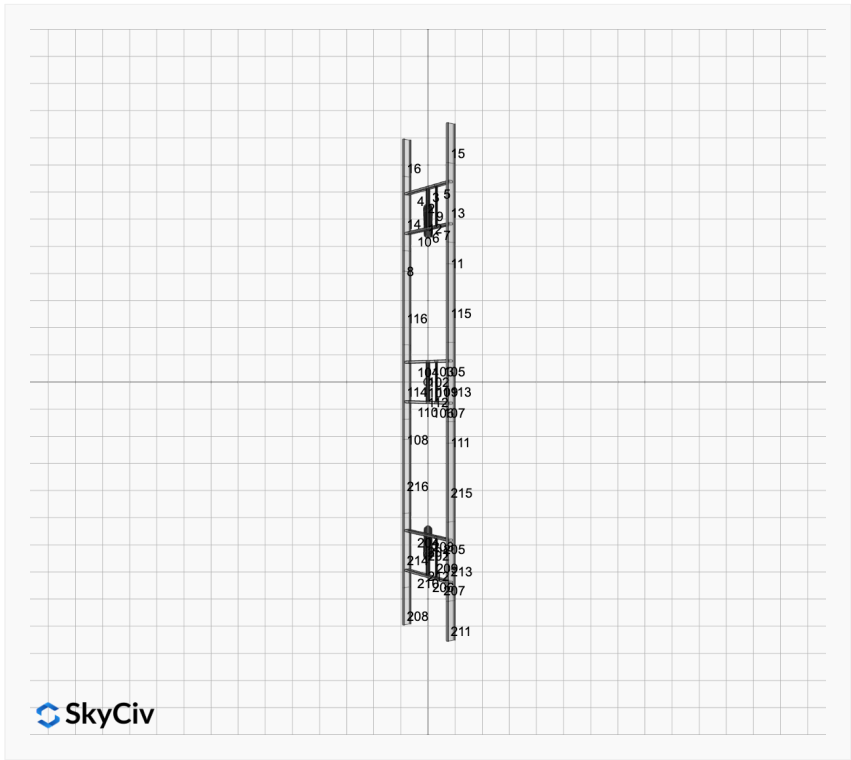
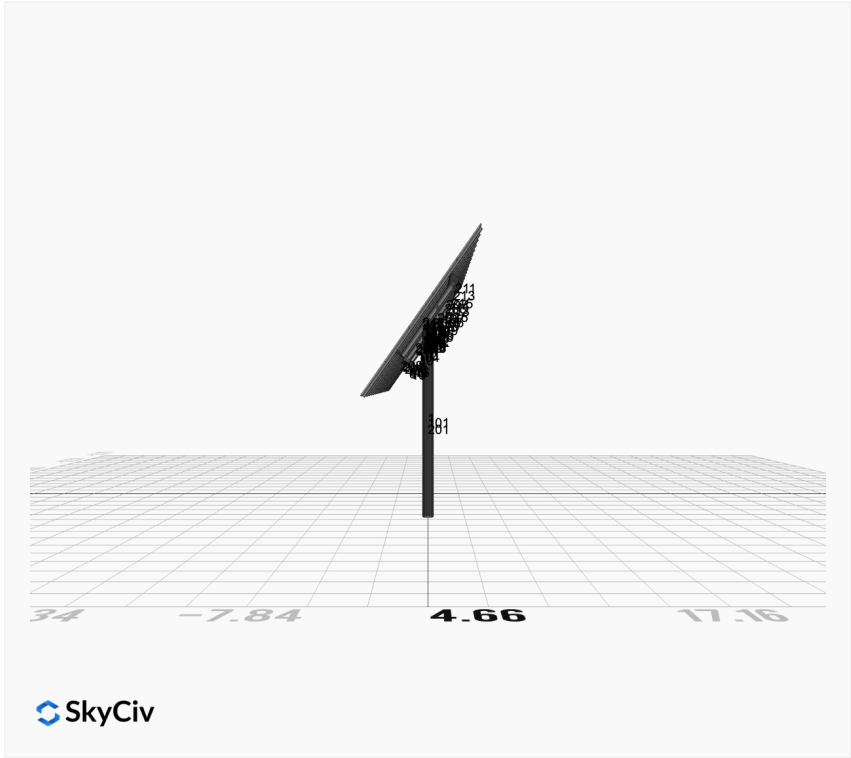

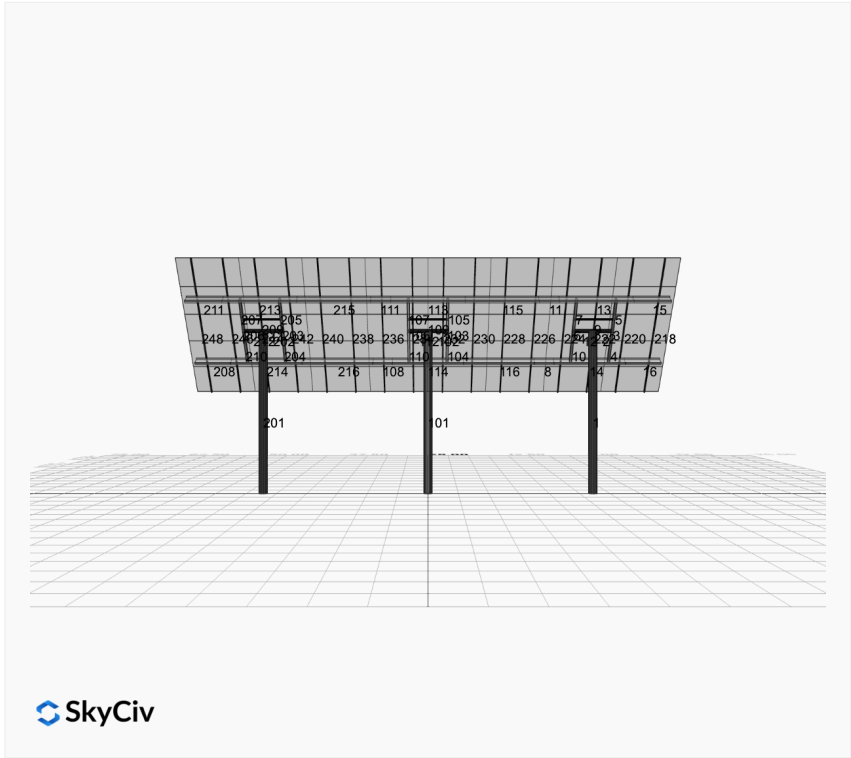
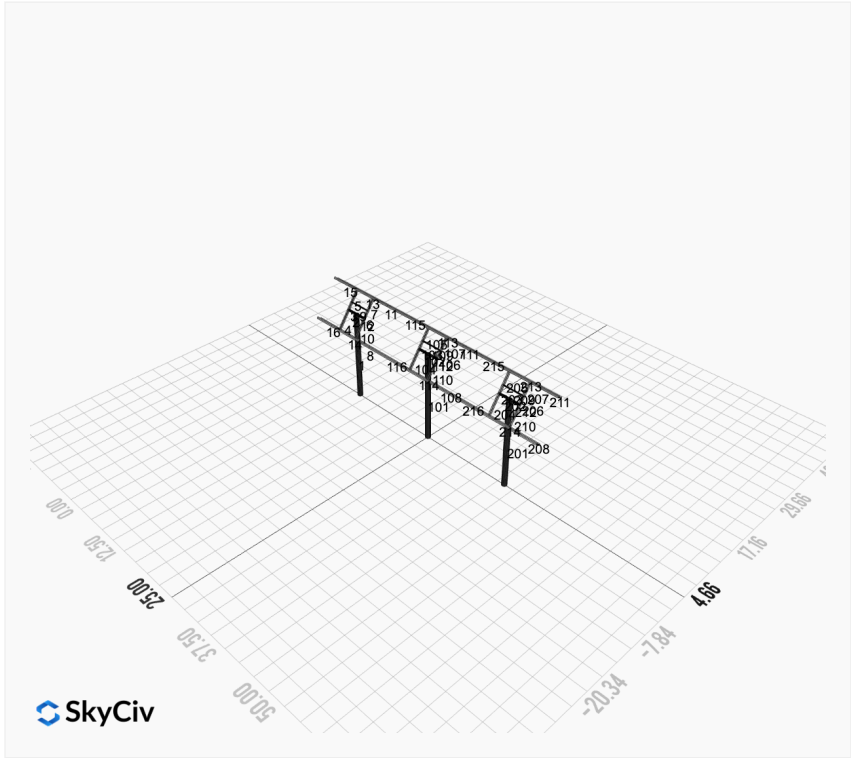

# FEM Results (Envelope Worst Case for each member)

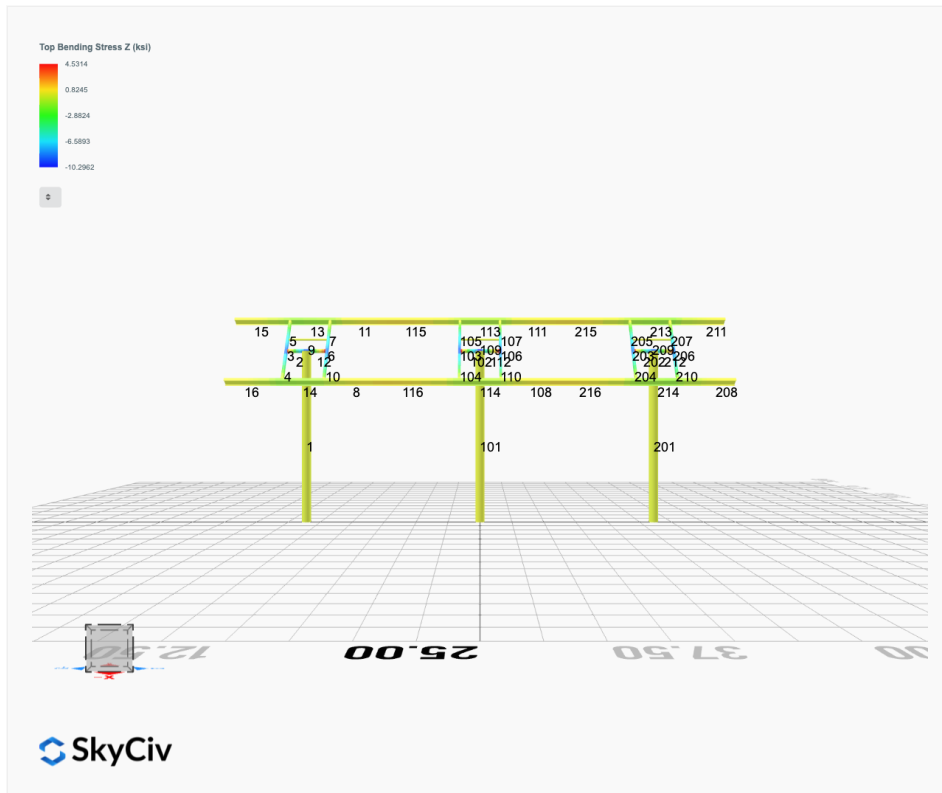
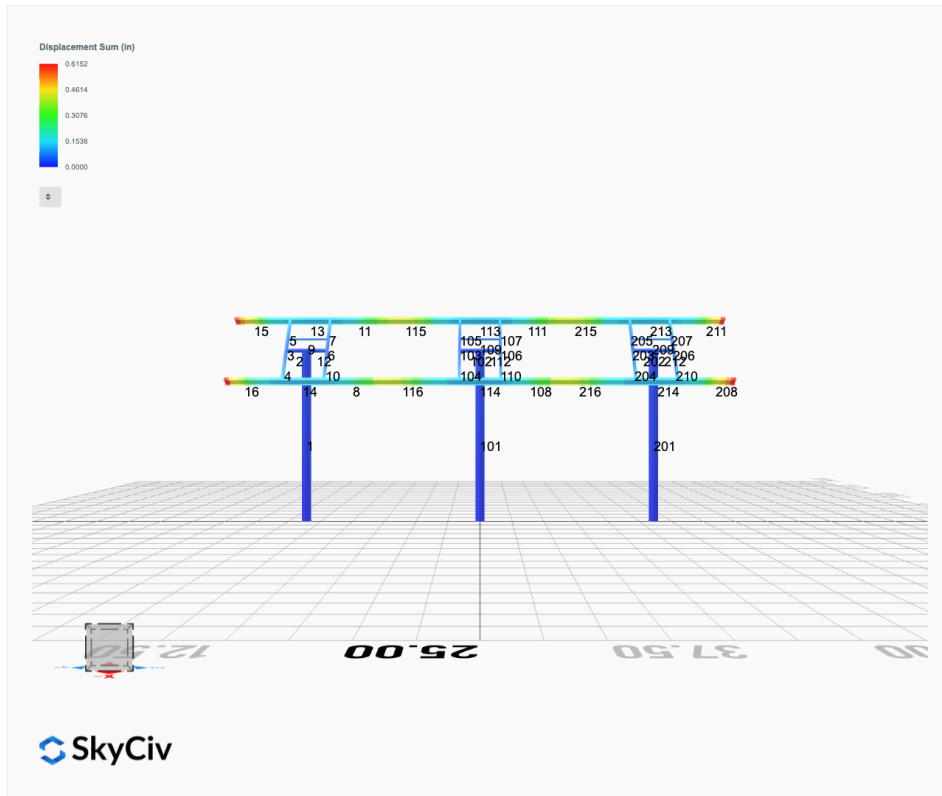

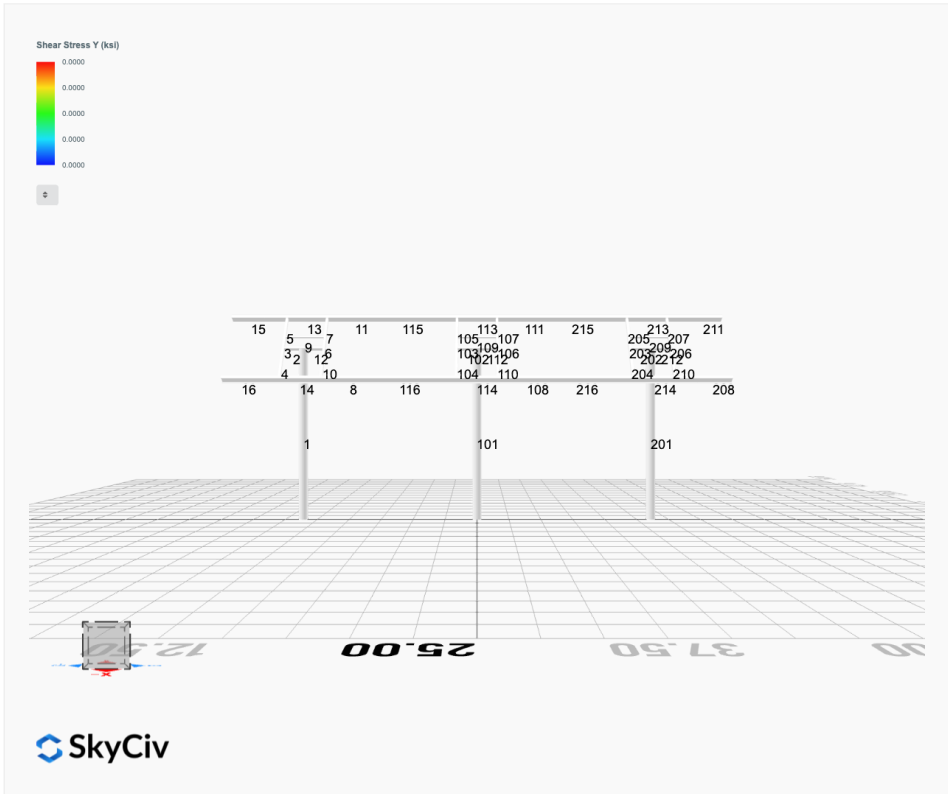
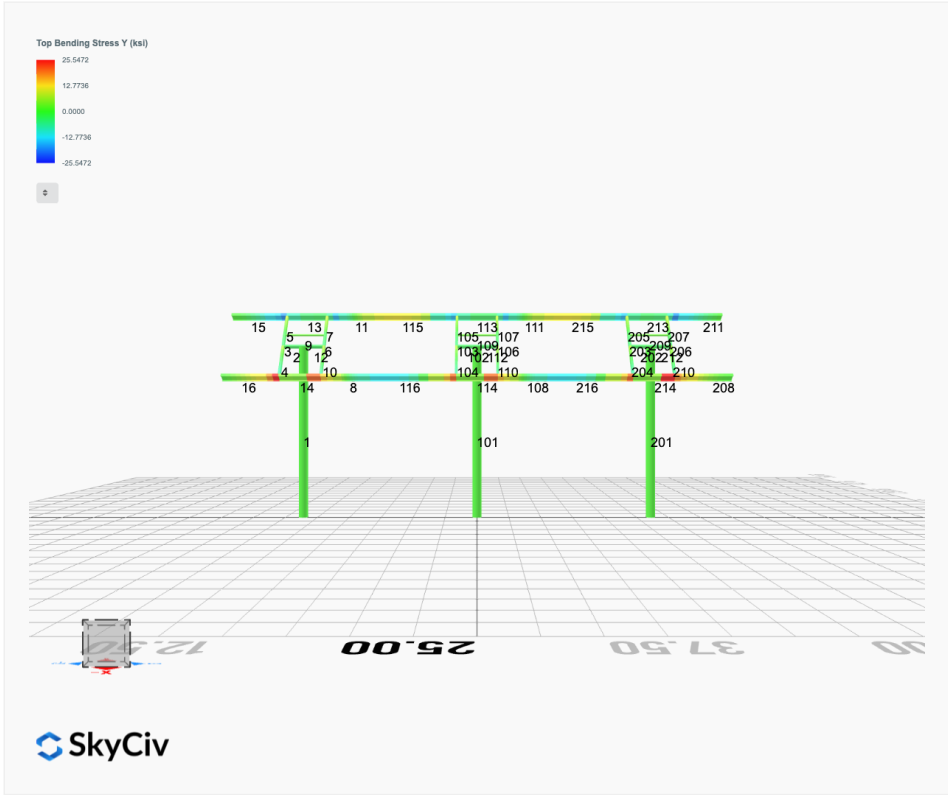

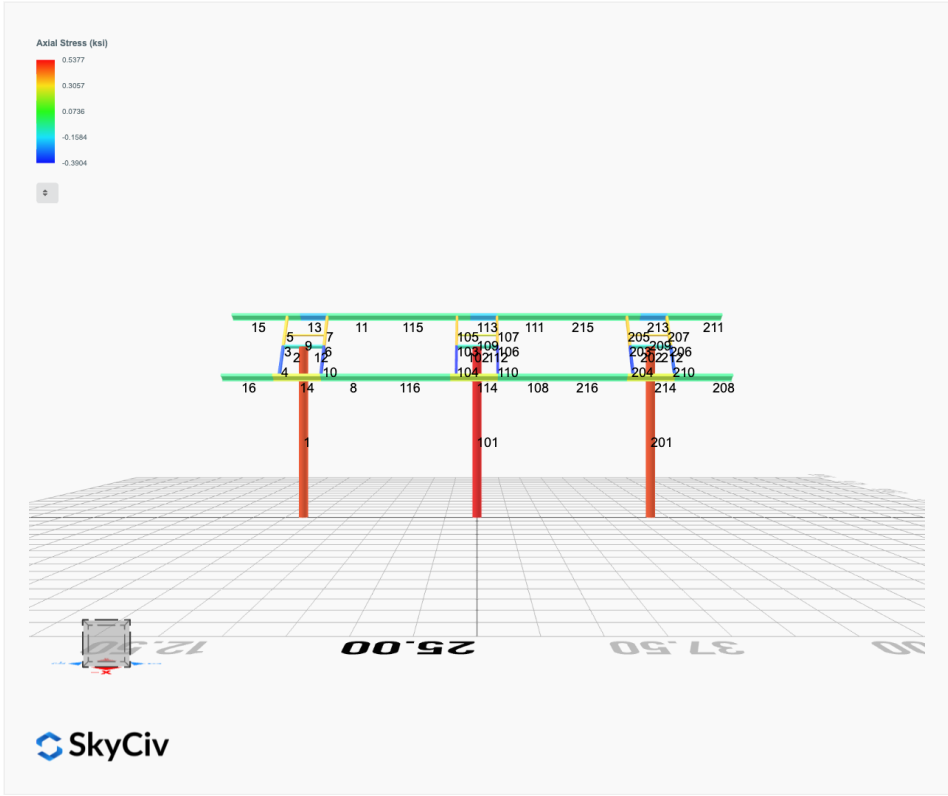

## Reaction Forces for Foundation 1 (Node ID#1), (kip, kip-ft)

### ASD Load Combination Results

Name	Fx	Fy	Fz	Mx	My	Mz
ULS: 1. D	-0.0041	2.5844	-0.0002	0.0005	0.0496	0.0807
ULS: 2. D + L	-0.0041	2.5844	-0.0002	0.0005	0.0496	0.0807
ULS: 3. D + (S or Lr or R)	-0.0189	8.6531	-0.0007	0.0044	0.2313	0.3390
ULS: 3. D + (S or Lr or R)	-0.0041	2.5844	-0.0002	0.0005	0.0496	0.0807
ULS: 4. D + 0.75L + 0.75(S or Lr or R)	-0.0152	7.1360	-0.0006	0.0034	0.1859	0.2744
ULS: 4. D + 0.75L + 0.75(S or Lr or R)	-0.0041	2.5844	-0.0002	0.0005	0.0496	0.0807
ULS: 5b. D + 0.7E	-0.0041	2.5844	-0.0002	0.0005	0.0496	0.0807
ULS: 6b. D + 0.75L + 0.75(0.7)E + 0.75S	-0.0152	7.1360	-0.0006	0.0034	0.1859	0.2744
ULS: 8. 0.6D + 0.7E	-0.0025	1.5507	-0.0001	0.0003	0.0298	0.0484
ULS: 5a. D + 0.6W_Wind downforce Case A only	-2.5949	4.3958	-0.0018	-0.0079	0.0605	43.8498
ULS: 5a. D + 0.6W_Wind downforce Case B only	-0.0041	2.5844	-0.0002	0.0005	0.0496	0.0807
ULS: 5a. D + 0.6W_Wind uplift Case A only	2.5865	0.7732	0.0015	0.0092	0.0380	-42.9280
ULS: 5a. D + 0.6W_Wind uplift Case B only	-0.0041	2.5844	-0.0002	0.0005	0.0496	0.0807
ULS: 6a. D + 0.75L + 0.75(0.6)W + 0.75(S or Lr or R)_Wind downforce Case A only	-1.9583	8.4945	-0.0018	-0.0028	0.1940	33.1012
ULS: 6a. D + 0.75L + 0.75(0.6)W + 0.75(S or Lr or R)_Wind downforce Case B only	-0.0152	7.1360	-0.0006	0.0034	0.1859	0.2744
ULS: 6a. D + 0.75L + 0.75(0.6)W + 0.75(S or Lr or R)_Wind uplift Case A only	1.9277	5.7775	0.0007	0.0100	0.1772	-31.9821
ULS: 6a. D + 0.75L + 0.75(0.6)W + 0.75(S or Lr or R)_Wind uplift Case B only	-0.0152	7.1360	-0.0006	0.0034	0.1859	0.2744
ULS: 6a. D + 0.75L + 0.75(0.6)W + 0.75(S or Lr or R)_Wind downforce Case A only	-1.9472	3.9429	-0.0014	-0.0058	0.0578	32.9075
ULS: 6a. D + 0.75L + 0.75(0.6)W + 0.75(S or Lr or R)_Wind downforce Case B only	-0.0041	2.5844	-0.0002	0.0005	0.0496	0.0807
ULS: 6a. D + 0.75L + 0.75(0.6)W + 0.75(S or Lr or R)_Wind uplift Case A only	1.9388	1.2260	0.0011	0.0070	0.0409	-32.1758
ULS: 6a. D + 0.75L + 0.75(0.6)W + 0.75(S or Lr or R)_Wind uplift Case B only	-0.0041	2.5844	-0.0002	0.0005	0.0496	0.0807
ULS: 7. 0.6D + 0.6W_Wind downforce Case A only	-2.5933	3.3620	-0.0018	-0.0080	0.0407	43.8175
ULS: 7. 0.6D + 0.6W_Wind downforce Case B only	-0.0025	1.5507	-0.0001	0.0003	0.0298	0.0484
ULS: 7. 0.6D + 0.6W_Wind uplift Case A only	2.5881	-0.2606	0.0016	0.0090	0.0182	-42.9602
ULS: 7. 0.6D + 0.6W_Wind uplift Case B only	-0.0025	1.5507	-0.0001	0.0003	0.0298	0.0484

### Worst Case Reactions LRFD

These calculations are taken directly from the FEA via SkyCiv and are used in the Concrete Checks of the Foundation Module.  
Note: Worst case values are assumed as downforce wind load cases.

Result	Value (kip, kip-ft)
Axial	14.3211
Shear X	-4.3313
Shear Z	-0.0030
Moment X	0.0160
Moment Y (Twist)	0.3576
Moment Z	74.5863

### Worst Case Reactions ASD

These results are taken from the worst case values in the above table and are used in the Soil Checks in the Foundation Module.  
Note: Worst case values are assumed as downforce wind load cases.

Result	Value (kip, kip-ft)
Axial	8.6531
Shear X	-2.5949
Shear Z	-0.0018
Moment X	0.0100
Moment Y (Twist)	0.2313
Moment Z	43.8498

## Reaction Forces for Foundation 2 (Node ID#101), (kip, kip-ft)

### ASD Load Combination Results

Name	Fx	Fy	Fz	Mx	My	Mz
ULS: 1. D	0.0082	2.6742	-0.0000	0.0000	0.0000	-0.1004
ULS: 2. D + L	0.0082	2.6742	-0.0000	0.0000	0.0000	-0.1004
ULS: 3. D + (S or Lr or R)	0.0379	9.0772	0.0000	0.0000	0.0000	-0.5045
ULS: 3. D + (S or Lr or R)	0.0082	2.6742	-0.0000	0.0000	0.0000	-0.1004
ULS: 4. D + 0.75L + 0.75(S or Lr or R)	0.0305	7.4765	-0.0000	0.0000	0.0000	-0.4035
ULS: 4. D + 0.75L + 0.75(S or Lr or R)	0.0082	2.6742	-0.0000	0.0000	0.0000	-0.1004
ULS: 5b. D + 0.7E	0.0082	2.6742	-0.0000	0.0000	0.0000	-0.1004

Name	Fx	Fy	Fz	Mx	My	Mz
ULS: 6b. D + 0.75L + 0.75(0.7)E + 0.75S	0.0305	7.4765	-0.0000	0.0000	0.0000	-0.4035
ULS: 8. 0.6D + 0.7E	0.0049	1.6045	-0.0000	0.0000	0.0000	-0.0602
ULS: 5a. D + 0.6W_Wind downforce Case A only	-2.6053	4.5097	-0.0000	0.0000	0.0000	44.0125
ULS: 5a. D + 0.6W_Wind downforce Case B only	0.0082	2.6742	-0.0000	0.0000	0.0000	-0.1004
ULS: 5a. D + 0.6W_Wind uplift Case A only	2.6221	0.8385	-0.0000	0.0000	0.0000	-43.4498
ULS: 5a. D + 0.6W_Wind uplift Case B only	0.0082	2.6742	-0.0000	0.0000	0.0000	-0.1004
ULS: 6a. D + 0.75L + 0.75(0.6)W + 0.75(S or Lr or R)_Wind downforce Case A only	-1.9296	8.8531	-0.0000	0.0000	0.0000	32.6812
ULS: 6a. D + 0.75L + 0.75(0.6)W + 0.75(S or Lr or R)_Wind downforce Case B only	0.0305	7.4765	-0.0000	0.0000	0.0000	-0.4035
ULS: 6a. D + 0.75L + 0.75(0.6)W + 0.75(S or Lr or R)_Wind uplift Case A only	1.9909	6.0997	-0.0000	0.0000	0.0000	-32.9155
ULS: 6a. D + 0.75L + 0.75(0.6)W + 0.75(S or Lr or R)_Wind uplift Case B only	0.0305	7.4765	-0.0000	0.0000	0.0000	-0.4035
ULS: 6a. D + 0.75L + 0.75(0.6)W + 0.75(S or Lr or R)_Wind downforce Case A only	-1.9519	4.0509	-0.0000	0.0000	0.0000	32.9843
ULS: 6a. D + 0.75L + 0.75(0.6)W + 0.75(S or Lr or R)_Wind downforce Case B only	0.0082	2.6742	-0.0000	0.0000	0.0000	-0.1004
ULS: 6a. D + 0.75L + 0.75(0.6)W + 0.75(S or Lr or R)_Wind uplift Case A only	1.9686	1.2974	-0.0000	0.0000	0.0000	-32.6125
ULS: 6a. D + 0.75L + 0.75(0.6)W + 0.75(S or Lr or R)_Wind uplift Case B only	0.0082	2.6742	-0.0000	0.0000	0.0000	-0.1004
ULS: 7. 0.6D + 0.6W_Wind downforce Case A only	-2.6085	3.4400	-0.0000	0.0000	0.0000	44.0526
ULS: 7. 0.6D + 0.6W_Wind downforce Case B only	0.0049	1.6045	-0.0000	0.0000	0.0000	-0.0602
ULS: 7. 0.6D + 0.6W_Wind uplift Case A only	2.6189	-0.2312	-0.0000	0.0000	0.0000	-43.4097
ULS: 7. 0.6D + 0.6W_Wind uplift Case B only	0.0049	1.6045	-0.0000	0.0000	0.0000	-0.0602

#### Worst Case Reactions LRFD

These calculations are taken directly from the FEA via SkyCiv and are used in the Concrete Checks of the Foundation Module.  
Note: Worst case values are assumed as downforce wind load cases.

Result	Value (kip, kip-ft)
Axial	14.9826
Shear X	-4.3792
Shear Z	-0.0000
Moment X	0.0001
Moment Y (Twist)	0.0002
Moment Z	74.6227

#### Worst Case Reactions ASD

These results are taken from the worst case values in the above table and are used in the Soil Checks in the Foundation Module.  
Note: Worst case values are assumed as downforce wind load cases.

Result	Value (kip, kip-ft)
Axial	9.0772
Shear X	-2.6221
Shear Z	-0.0000
Moment X	0.0000
Moment Y (Twist)	0.0000
Moment Z	44.0526

#### Reaction Forces for Foundation 3 (Node ID#201), (kip, kip-ft)

##### ASD Load Combination Results

Name	Fx	Fy	Fz	Mx	My	Mz
ULS: 1. D	-0.0041	2.5844	0.0002	-0.0005	-0.0496	0.0807
ULS: 2. D + L	-0.0041	2.5844	0.0002	-0.0005	-0.0496	0.0807
ULS: 3. D + (S or Lr or R)	-0.0189	8.6531	0.0007	-0.0044	-0.2313	0.3390
ULS: 3. D + (S or Lr or R)	-0.0041	2.5844	0.0002	-0.0005	-0.0496	0.0807
ULS: 4. D + 0.75L + 0.75(S or Lr or R)	-0.0152	7.1360	0.0006	-0.0034	-0.1859	0.2744
ULS: 4. D + 0.75L + 0.75(S or Lr or R)	-0.0041	2.5844	0.0002	-0.0005	-0.0496	0.0807
ULS: 5b. D + 0.7E	-0.0041	2.5844	0.0002	-0.0005	-0.0496	0.0807
ULS: 6b. D + 0.75L + 0.75(0.7)E + 0.75S	-0.0152	7.1360	0.0006	-0.0034	-0.1859	0.2744
ULS: 8. 0.6D + 0.7E	-0.0025	1.5507	0.0001	-0.0003	-0.0298	0.0484
ULS: 5a. D + 0.6W_Wind downforce Case A only	-2.5949	4.3958	0.0018	0.0079	-0.0605	43.8498
ULS: 5a. D + 0.6W_Wind downforce Case B only	-0.0041	2.5844	0.0002	-0.0005	-0.0496	0.0807
ULS: 5a. D + 0.6W_Wind uplift Case A only	2.5865	0.7732	-0.0015	-0.0092	-0.0380	-42.9279
ULS: 5a. D + 0.6W_Wind uplift Case B only	-0.0041	2.5844	0.0002	-0.0005	-0.0496	0.0807
ULS: 6a. D + 0.75L + 0.75(0.6)W + 0.75(S or Lr or R)_Wind downforce Case A only	-1.9583	8.4945	0.0018	0.0028	-0.1940	33.1012
ULS: 6a. D + 0.75L + 0.75(0.6)W + 0.75(S or Lr or R)_Wind downforce Case B only	-0.0152	7.1360	0.0006	-0.0034	-0.1859	0.2744
ULS: 6a. D + 0.75L + 0.75(0.6)W + 0.75(S or Lr or R)_Wind uplift Case A only	1.9277	5.7775	-0.0007	-0.0100	-0.1772	-31.9821
ULS: 6a. D + 0.75L + 0.75(0.6)W + 0.75(S or Lr or R)_Wind uplift Case B only	-0.0152	7.1360	0.0006	-0.0034	-0.1859	0.2744

Name	Fx	Fy	Fz	Mx	My	Mz
ULS: 6a. D + 0.75L + 0.75(0.6)W + 0.75(S or Lr or R)_Wind downforce Case A only	-1.9472	3.9429	0.0014	0.0058	-0.0578	32.9075
ULS: 6a. D + 0.75L + 0.75(0.6)W + 0.75(S or Lr or R)_Wind downforce Case B only	-0.0041	2.5844	0.0002	-0.0005	-0.0496	0.0807
ULS: 6a. D + 0.75L + 0.75(0.6)W + 0.75(S or Lr or R)_Wind uplift Case A only	1.9388	1.2260	-0.0011	-0.0070	-0.0409	-32.1758
ULS: 6a. D + 0.75L + 0.75(0.6)W + 0.75(S or Lr or R)_Wind uplift Case B only	-0.0041	2.5844	0.0002	-0.0005	-0.0496	0.0807
ULS: 7. 0.6D + 0.6W_Wind downforce Case A only	-2.5933	3.3620	0.0018	0.0081	-0.0407	43.8175
ULS: 7. 0.6D + 0.6W_Wind downforce Case B only	-0.0025	1.5507	0.0001	-0.0003	-0.0298	0.0484
ULS: 7. 0.6D + 0.6W_Wind uplift Case A only	2.5881	-0.2606	-0.0016	-0.0090	-0.0182	-42.9602
ULS: 7. 0.6D + 0.6W_Wind uplift Case B only	-0.0025	1.5507	0.0001	-0.0003	-0.0298	0.0484

### Worst Case Reactions LRFD

These calculations are taken directly from the FEA via SkyCiv and are used in the Concrete Checks of the Foundation Module.  
Note: Worst case values are assumed as downforce wind load cases.

Result	Value (kip, kip-ft)
Axial	14.3212
Shear X	-4.3313
Shear Z	0.0030
Moment X	-0.0158
Moment Y (Twist)	0.3575
Moment Z	74.5874

### Worst Case Reactions ASD

These results are taken from the worst case values in the above table and are used in the Soil Checks in the Foundation Module.  
Note: Worst case values are assumed as downforce wind load cases.

Result	Value (kip, kip-ft)
Axial	8.6531
Shear X	-2.5949
Shear Z	0.0018
Moment X	-0.0100
Moment Y (Twist)	0.2313
Moment Z	43.8498

## Project Details

Design Code: AISC 360-16 LRFD  
 Provision: LRFD  
 Country: United States  
 User Name: sales@mtsolar.us  
 Unit System: imperial



## Design Input Information

Design Factors			
$\Phi_t$	$\Phi_c$	$\Phi_b$	$\Phi_v$
0.9	0.9	0.9	0.9

Design Materials			
ID	E (ksi)	$F_y$ (ksi)	$F_u$ (ksi)
1	29000	50	65

### Section Dimensions



ID	Name	d (in)	$t_w$ (in)				
3	2in Pipe Sch 120	2.38	0.25				
6	4in Pipe Sch 120	4.50	0.44				
11	10in Pipe Sch 40	10.75	0.36				

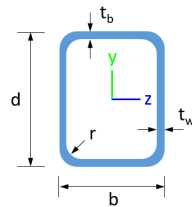

ID	Name	d (in)	b (in)	$t_w$ (in)	$t_b$ (in)	r (in)	
17	HSS5x3x1/4	5.00	3.00	0.23	0.23	0.23	



ID	Name	d (in)	$t_w$ (in)	$b_t$ (in)	$b_b$ (in)	$t_t$ (in)	$t_b$ (in)	r (in)
20	W10x12	9.87	0.19	3.96	3.96	0.21	0.21	0.30

### Section Properties

ID	Name	A (in <sup>2</sup> )	J (in <sup>4</sup> )	$I_{yp}$ (in <sup>4</sup> )	$I_{zp}$ (in <sup>4</sup> )	$I_w$ (in <sup>6</sup> )	$S_{yp}$ (in <sup>3</sup> )	$S_{zp}$ (in <sup>3</sup> )
3	2in Pipe Sch 120	1.67	1.91	0.96	0.96	0.00	1.13	1.13
6	4in Pipe Sch 120	5.58	23.29	11.64	11.64	0.00	7.24	7.24
11	10in Pipe Sch 40	11.91	321.47	160.73	160.73	0.00	39.38	39.38



108	20	1.33	1.33	2.0 5	1.67,1.68,1.67,1.68,1.67,1.67,1.55,1.68,1.37,1.68,1.52,1.67,1.47,1.67,1.62,1.68,1.87,1.68,1.5 4,1.67,1.41,1.67,1.52,1.67,1.48,1.67	3 0 0	2 0 0	1
109	3	2.60	2.60	4.0 0	-	3 0 0	2 0 0	1
110	17	2.44	2.44	3.7 5	1.69,1.68,1.69,1.67,1.68,1.69,1.67,1.68,1.66,1.68,1.67,1.69,1.66,1.69,1.67,1.67,1.68,1.67,1.6 7,1.69,1.65,1.69,1.67,1.69,1.66,1.69	3 0 0	2 0 0	1
111	20	1.33	1.33	2.0 5	1.81,1.82,1.81,1.82,1.82,1.81,1.55,1.82,1.28,1.82,1.51,1.81,1.41,1.81,1.68,1.82,2.05,1.82,1.5 4,1.81,1.34,1.81,1.50,1.81,1.43,1.81	3 0 0	2 0 0	1
112	6	1.30	1.30	2.0 0	-	3 0 0	2 0 0	1
113	20	4.88	4.00	7.5 0	1.05,1.05,1.05,1.05,1.05,1.05,1.06,1.05,1.10,1.05,1.06,1.05,1.07,1.05,1.06,1.05,1.05,1.05,1.0 6,1.05,1.09,1.05,1.06,1.05,1.07,1.05	3 0 0	2 0 0	1
114	20	4.88	4.00	7.5 0	1.05,1.05,1.05,1.05,1.05,1.05,1.06,1.05,1.08,1.05,1.06,1.05,1.07,1.05,1.06,1.05,1.05,1.05,1.0 6,1.05,1.07,1.05,1.06,1.05,1.06,1.05	3 0 0	2 0 0	1
115	20	4.84	4.84	7.4 5	1.15,1.15,1.15,1.15,1.15,1.15,1.12,1.15,1.07,1.15,1.11,1.15,1.10,1.15,1.13,1.15,1.18,1.15,1.1 2,1.15,1.08,1.15,1.11,1.15,1.10,1.15	3 0 0	2 0 0	1
116	20	4.84	4.84	7.4 5	1.13,1.13,1.13,1.13,1.13,1.13,1.12,1.13,1.09,1.13,1.12,1.13,1.11,1.13,1.13,1.13,1.15,1.13,1.1 2,1.13,1.10,1.13,1.12,1.13,1.11,1.13	3 0 0	2 0 0	1
201	11	35.1 6	35.1 6	16. 74	-	3 0 0	2 0 0	1
202	6	1.30	1.30	2.0 0	-	3 0 0	2 0 0	1
203	17	0.92	0.92	1.4 2	1.19,1.18,1.19,1.18,1.18,1.19,1.18,1.18,1.17,1.18,1.18,1.19,1.17,1.19,1.18,1.18,1.18,1.1 8,1.19,1.17,1.19,1.18,1.19,1.18,1.19	3 0 0	2 0 0	1
204	17	2.44	2.44	3.7 5	1.69,1.68,1.69,1.67,1.68,1.69,1.67,1.68,1.66,1.68,1.67,1.69,1.66,1.69,1.67,1.67,1.68,1.67,1.6 7,1.69,1.65,1.69,1.67,1.69,1.66,1.69	3 0 0	2 0 0	1
205	17	1.52	1.52	2.3 3	1.68,1.67,1.68,1.67,1.68,1.68,1.67,1.67,1.66,1.67,1.67,1.68,1.66,1.68,1.67,1.67,1.67,1.67,1.6 7,1.68,1.66,1.68,1.67,1.68,1.66,1.68	3 0 0	2 0 0	1
206	17	0.92	0.92	1.4 2	1.19,1.18,1.19,1.18,1.19,1.19,1.18,1.18,1.17,1.18,1.18,1.19,1.17,1.19,1.18,1.18,1.18,1.1 8,1.19,1.17,1.19,1.18,1.19,1.18,1.19	3 0 0	2 0 0	1
207	17	1.52	1.52	2.3 3	1.68,1.67,1.68,1.67,1.68,1.68,1.67,1.67,1.66,1.67,1.67,1.68,1.66,1.68,1.67,1.67,1.67,1.6 7,1.68,1.65,1.68,1.67,1.68,1.66,1.68	3 0 0	2 0 0	1
208	20	7.88	7.88	3.7 5	2.33,2.33,2.33,2.33,2.33,2.33,2.33,2.33,2.33,2.33,2.33,2.33,2.33,2.33,2.33,2.33,2.33,2.3 3,2.33,2.33,2.33,2.33,2.33,2.33,2.33	3 0 0	2 0 0	1
209	3	2.60	2.60	4.0 0	-	3 0 0	2 0 0	1
210	17	2.44	2.44	3.7 5	1.69,1.68,1.69,1.67,1.68,1.69,1.67,1.68,1.66,1.68,1.67,1.69,1.66,1.69,1.67,1.67,1.68,1.67,1.6 7,1.69,1.65,1.69,1.67,1.69,1.66,1.69	3 0 0	2 0 0	1
211	20	7.88	7.88	3.7 5	2.33,2.33,2.33,2.33,2.33,2.33,2.33,2.33,2.33,2.33,2.33,2.33,2.33,2.33,2.33,2.33,2.33,2.3 3,2.33,2.33,2.33,2.33,2.33,2.33,2.33	3 0 0	2 0 0	1
212	6	1.30	1.30	2.0 0	-	3 0 0	2 0 0	1
213	20	4.88	4.00	7.5 0	1.11,1.12,1.11,1.12,1.11,1.11,1.11,1.12,1.11,1.12,1.11,1.11,1.11,1.11,1.11,1.12,1.12,1.1 1,1.11,1.11,1.11,1.11,1.11,1.11,1.11	3 0 0	2 0 0	1
214	20	4.88	4.00	7.5 0	1.11,1.11,1.11,1.11,1.11,1.11,1.11,1.11,1.11,1.11,1.11,1.11,1.11,1.11,1.11,1.12,1.11,1.1 1,1.11,1.11,1.11,1.11,1.11,1.11,1.11	3 0 0	2 0 0	1
215	20	4.84	4.84	7.4 5	1.16,1.16,1.16,1.16,1.16,1.16,1.16,1.16,1.18,1.16,1.16,1.16,1.16,1.16,1.16,1.16,1.16,1.1 6,1.16,1.17,1.16,1.16,1.16,1.16,1.16	3 0 0	2 0 0	1
216	20	4.84	4.84	7.4 5	1.16,1.16,1.16,1.16,1.16,1.16,1.16,1.16,1.16,1.16,1.16,1.16,1.16,1.16,1.16,1.16,1.16,1.1 6,1.16,1.16,1.16,1.16,1.16,1.16,1.16	3 0 0	2 0 0	1

Member Design Capacity

## Member Design Capacity

Member ID	$\Phi_t P_n$ (kip)	$\Phi_c P_n$ (kip)	$\Phi_b M_{zn}$ (k-ft)	$\Phi_b M_{yn}$ (k-ft)	$\Phi_v V_{yn}$ (kip)	$\Phi_v V_{zn}$ (kip)
1	535.87	204.03	147.68	147.68	160.76	160.76
2	251.01	248.88	27.16	27.16	75.30	75.30
3	151.65	150.70	20.17	14.14	54.12	28.95
4	151.65	145.15	20.17	14.14	54.12	28.95
5	151.65	149.10	20.17	14.14	54.12	28.95
6	151.65	150.70	20.17	14.14	54.12	28.95
7	151.65	149.10	20.17	14.14	54.12	28.95
8	159.30	142.47	46.90	6.46	56.26	44.91
9	75.10	66.32	4.25	4.25	22.53	22.53
10	151.65	145.15	20.17	14.14	54.12	28.95
11	159.30	142.47	46.90	6.46	56.26	44.91
12	251.01	248.88	27.16	27.16	75.30	75.30
13	159.30	116.35	33.92	6.46	56.26	44.91
14	159.30	116.35	33.92	6.46	56.26	44.91
15	159.30	55.15	46.90	6.46	56.26	44.91
16	159.30	55.15	46.90	6.46	56.26	44.91
101	535.87	204.03	147.68	147.68	160.76	160.76
102	251.01	248.88	27.16	27.16	75.30	75.30
103	151.65	150.70	20.17	14.14	54.12	28.95
104	151.65	145.15	20.17	14.14	54.12	28.95
105	151.65	149.10	20.17	14.14	54.12	28.95
106	151.65	150.70	20.17	14.14	54.12	28.95
107	151.65	149.10	20.17	14.14	54.12	28.95
108	159.30	142.47	46.90	6.46	56.26	44.91
109	75.10	66.32	4.25	4.25	22.53	22.53
110	151.65	145.15	20.17	14.14	54.12	28.95
111	159.30	142.47	46.90	6.46	56.26	44.91
112	251.01	248.88	27.16	27.16	75.30	75.30
113	159.30	116.35	32.09	6.46	56.26	44.91
114	159.30	116.35	32.09	6.46	56.26	44.91
115	159.30	104.63	32.89	6.46	56.26	44.91
116	159.30	104.63	33.50	6.46	56.26	44.91
201	535.87	204.03	147.68	147.68	160.76	160.76
202	251.01	248.88	27.16	27.16	75.30	75.30
203	151.65	150.70	20.17	14.14	54.12	28.95
204	151.65	145.15	20.17	14.14	54.12	28.95
205	151.65	149.10	20.17	14.14	54.12	28.95
206	151.65	150.70	20.17	14.14	54.12	28.95
207	151.65	149.10	20.17	14.14	54.12	28.95
208	159.30	55.15	46.90	6.46	56.26	44.91
209	75.10	66.32	4.25	4.25	22.53	22.53
210	151.65	145.15	20.17	14.14	54.12	28.95
211	159.30	55.15	46.90	6.46	56.26	44.91
212	251.01	248.88	27.16	27.16	75.30	75.30
213	159.30	116.35	33.92	6.46	56.26	44.91
214	159.30	116.35	33.92	6.46	56.26	44.91
215	159.30	104.63	35.66	6.46	56.26	44.91
216	159.30	104.63	35.66	6.46	56.26	44.91

## Design Ratio

Member ID	P	M <sub>z</sub>	M <sub>y</sub>	V <sub>y</sub>	V <sub>z</sub>	(P,M <sub>z</sub> ,M <sub>y</sub> )	Worst LC	KL/r	φ	Status
1	0.070	0.505	0.000	0.027	0.000	0.528	#13	0.574	Not Required	Pass
2	0.003	0.355	0.167	0.089	0.029	0.489	#21	0.036	Not Required	Pass
3	0.016	0.450	0.106	0.044	0.022	0.563	#21	0.046	Not Required	Pass
4	0.016	0.445	0.235	0.044	0.051	0.610	#21	0.082	Not Required	Pass
5	0.016	0.279	0.241	0.044	0.060	0.332	#21	0.076	Not Required	Pass
6	0.017	0.439	0.113	0.043	0.022	0.561	#21	0.046	Not Required	Pass
7	0.017	0.273	0.234	0.043	0.061	0.337	#21	0.076	Not Required	Pass
8	0.000	0.036	0.183	0.025	0.032	0.218	#21	0.068	Not Required	Pass
9	0.017	0.022	0.047	0.001	0.000	0.074	#21	0.206	Not Required	Pass
10	0.016	0.436	0.229	0.043	0.052	0.613	#21	0.082	Not Required	Pass
11	0.000	0.035	0.180	0.025	0.032	0.215	#21	0.102	Not Required	Pass
12	0.003	0.354	0.161	0.090	0.029	0.475	#21	0.036	Not Required	Pass
13	0.011	0.142	0.698	0.034	0.043	0.826	#21	0.306	Not Required	Pass
14	0.013	0.144	0.698	0.034	0.043	0.827	#21	0.204	Not Required	Pass
15	0.000	0.043	0.325	0.019	0.025	0.368	#21	Not Required	Not Required	Pass
16	0.000	0.043	0.325	0.019	0.025	0.368	#21	Not Required	Not Required	Pass
101	0.073	0.505	0.000	0.027	0.000	0.529	#13	0.574	Not Required	Pass
102	0.002	0.371	0.163	0.094	0.029	0.497	#21	0.036	Not Required	Pass
103	0.017	0.461	0.125	0.046	0.029	0.594	#21	0.046	Not Required	Pass
104	0.017	0.454	0.217	0.045	0.049	0.623	#21	0.082	Not Required	Pass
105	0.017	0.287	0.221	0.045	0.055	0.339	#21	0.076	Not Required	Pass
106	0.017	0.461	0.125	0.045	0.029	0.594	#21	0.046	Not Required	Pass
107	0.017	0.287	0.221	0.045	0.055	0.339	#21	0.076	Not Required	Pass
108	0.000	0.041	0.185	0.024	0.031	0.226	#21	0.068	Not Required	Pass
109	0.011	0.018	0.046	0.001	0.000	0.065	#21	0.206	Not Required	Pass
110	0.017	0.454	0.217	0.045	0.049	0.623	#21	0.082	Not Required	Pass
111	0.000	0.040	0.183	0.024	0.031	0.222	#21	0.102	Not Required	Pass
112	0.002	0.371	0.163	0.094	0.029	0.497	#21	0.036	Not Required	Pass
113	0.010	0.111	0.623	0.033	0.043	0.718	#21	0.306	Not Required	Pass
114	0.012	0.110	0.621	0.033	0.043	0.712	#21	0.204	Not Required	Pass
115	0.000	0.080	0.349	0.024	0.031	0.430	#21	0.370	Not Required	Pass
116	0.000	0.083	0.351	0.024	0.031	0.434	#21	0.247	Not Required	Pass
201	0.070	0.505	0.000	0.027	0.000	0.528	#13	0.574	Not Required	Pass
202	0.003	0.354	0.161	0.090	0.029	0.475	#21	0.036	Not Required	Pass
203	0.017	0.439	0.113	0.043	0.022	0.561	#21	0.046	Not Required	Pass
204	0.016	0.436	0.229	0.043	0.052	0.613	#21	0.082	Not Required	Pass
205	0.017	0.273	0.234	0.043	0.061	0.337	#21	0.076	Not Required	Pass
206	0.016	0.450	0.106	0.044	0.022	0.563	#21	0.046	Not Required	Pass
207	0.016	0.279	0.241	0.044	0.060	0.333	#21	0.076	Not Required	Pass
208	0.000	0.043	0.325	0.019	0.025	0.368	#21	Not Required	Not Required	Pass
209	0.017	0.022	0.047	0.001	0.000	0.074	#21	0.206	Not Required	Pass
210	0.016	0.445	0.235	0.044	0.051	0.610	#21	0.082	Not Required	Pass
211	0.000	0.043	0.325	0.019	0.025	0.368	#21	Not Required	Not Required	Pass
212	0.003	0.355	0.167	0.089	0.029	0.489	#21	0.036	Not Required	Pass
213	0.011	0.142	0.698	0.034	0.043	0.827	#21	0.204	Not Required	Pass
214	0.013	0.144	0.698	0.034	0.043	0.827	#21	0.204	Not Required	Pass
215	0.000	0.079	0.349	0.025	0.032	0.428	#21	0.370	Not Required	Pass
216	0.000	0.080	0.351	0.025	0.032	0.432	#21	0.247	Not Required	Pass

## Definitions

Φ<sub>t</sub> Safety factor for tensile

$\Phi_c$	Safety factor for compression
$\Phi_b$	Safety factor for flexure
$\Phi_v$	Safety factor for shear
E	Modulus of elasticity
$F_y$	Specified minimum yield stress
$F_u$	Specified minimum tensile strength
A	Cross-sectional area
J	Torsional constant
$I_{yp}$	Moment of inertia about the Y axes
$I_{zp}$	Moment of inertia about the Z axes
$I_w$	Warping constant
$S_{yp}$	Plastic section modulus about the Y axis
$S_{zp}$	Plastic section modulus about the Z axis
KL	Effective length
$C_b$	Buckling modification factor (from all load combinations)
$L_b$	Length between braced points
LST	Limited slenderness for tension
LSC	Limited slenderness for compression
LD	Limited deflection
$P_n$	Nominal axial strength (tension/compression)
$M_n$	Nominal flexural strength (about Z/Y axis)
$V_n$	Nominal shear strength (along Z/Y axis)
P	Design ratio in case of axial force
$M_z$	Design ratio in case of bending about Z axis
$M_y$	Design ratio in case of bending about Y axis
$V_y$	Design ratio in case of shear along Y axis
$V_z$	Design ratio in case of shear along Z axis
(P, $M_z$ , $M_y$ )	Design ratio in case of axial force and bending action
KL/r	Design ratio in case of section slenderness
$\delta$	Design ratio in case of member deflection
OK	Capacity is provided
NG	Capacity is not provided

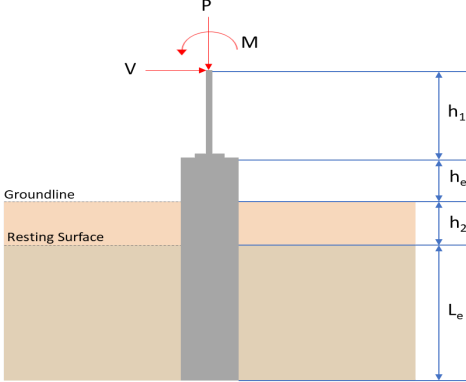
REFERENCES	CALCULATIONS	RESULTS																										
	<p><b>SkyCiv Foundation Design</b> Pile Foundation</p> <p><b>Design Information :</b> Design code : IBC 2021 (International Building Code) Unit System : Imperial</p>																											
	<p><b>Pile Input</b></p>  <p><b>Geometry</b> Pile shape: rectangular <math>b = 48</math> in - Pile width <math>D = 48</math> in - Pile depth <math>L = 7.75</math> ft - Total pile length <math>h_1 = 0</math> ft - Lateral load height from the top of the pile, <math>h_2 = 0</math> ft - Depth to resting surface <math>h_e = 0</math> ft - Length of pile above the ground</p> <p><b>Tabulation of Soil Parameters</b></p> <table border="1" data-bbox="416 1102 1193 1191"> <thead> <tr> <th>Layer</th> <th>Label</th> <th>Allowable Bearing Pressure (<math>q_n</math>) (psf)</th> <th>Allowable Lateral Pressure (<math>R</math>) (psf/ft)</th> </tr> </thead> <tbody> <tr> <td>1</td> <td>Sand, silty sand, clayey sand, silty gravel &amp; clayey gravel</td> <td>2000.000</td> <td>150.000</td> </tr> </tbody> </table> <p><b>Tabulation of Loads</b></p> <table border="1" data-bbox="676 1288 935 1458"> <thead> <tr> <th>Load Component</th> <th>ASD</th> <th>LRFD</th> </tr> </thead> <tbody> <tr> <td><math>P</math> (kip)</td> <td>8.653</td> <td>14.321</td> </tr> <tr> <td><math>V_x</math> (kip)</td> <td>-2.595</td> <td>-4.331</td> </tr> <tr> <td><math>V_z</math> (kip)</td> <td>-0.002</td> <td>-0.003</td> </tr> <tr> <td><math>M_x</math> (kipft)</td> <td>0.010</td> <td>0.016</td> </tr> <tr> <td><math>M_z</math> (kipft)</td> <td>43.850</td> <td>74.586</td> </tr> </tbody> </table> <p><b>Material Properties</b> <math>f'_{ck} = 2.5</math> ksi - Concrete strength,</p>	Layer	Label	Allowable Bearing Pressure ( $q_n$ ) (psf)	Allowable Lateral Pressure ( $R$ ) (psf/ft)	1	Sand, silty sand, clayey sand, silty gravel & clayey gravel	2000.000	150.000	Load Component	ASD	LRFD	$P$ (kip)	8.653	14.321	$V_x$ (kip)	-2.595	-4.331	$V_z$ (kip)	-0.002	-0.003	$M_x$ (kipft)	0.010	0.016	$M_z$ (kipft)	43.850	74.586	
Layer	Label	Allowable Bearing Pressure ( $q_n$ ) (psf)	Allowable Lateral Pressure ( $R$ ) (psf/ft)																									
1	Sand, silty sand, clayey sand, silty gravel & clayey gravel	2000.000	150.000																									
Load Component	ASD	LRFD																										
$P$ (kip)	8.653	14.321																										
$V_x$ (kip)	-2.595	-4.331																										
$V_z$ (kip)	-0.002	-0.003																										
$M_x$ (kipft)	0.010	0.016																										
$M_z$ (kipft)	43.850	74.586																										
	<p><b>Required depth to resist lateral loads (ASD)</b> <math>H</math> - Point of application of the lateral load</p> $H = h_1 + h_2 + h_e$ $H = (0 \text{ ft}) + (0 \text{ ft}) + (0 \text{ ft})$ $H = 0 \text{ ft}$ <p><b>Considering x-direction:</b> <math>H_o</math> - Lateral force per length of pile,</p> $H_o = \frac{V_x}{1.57 D}$ $H_o = \frac{(-2.595 \text{ kip})}{1.57 \times (48 \text{ in})}$ $H_o = -0.41322 \text{ kip/ft}$ <p><math>M_o</math> - Moment per length of pile,</p> $M_o = \frac{M_z + (V_x H)}{1.57 D}$																											

$$M_o = \frac{(43.85 \text{ kipft}) + ((-2.595 \text{ kip}) \times (0 \text{ ft}))}{1.57 \times (48 \text{ in})}$$

$$M_o = 6.9825 \text{ kipft/ft}$$

Required depth of embedment in earth:

$$L_x^3 - \left(14.14 \times \frac{H_o \times L_x}{R}\right) - \left(18.85 \times \frac{M_o}{R}\right) = 0$$

Solving the cubic equation:

$L_{e,x} = 7.2378 \text{ ft}$  - Required depth in x-direction,

**Considering z-direction:**

$H_o$  - Lateral force per length of pile,

$$H_o = \frac{V_z}{1.57 b}$$

$$H_o = \frac{(-0.002 \text{ kip})}{1.57 \times (48 \text{ in})}$$

$$H_o = -0.00031847 \text{ kip/ft}$$

$M_o$  - Moment per length of pile,

$$M_o = \frac{M_x + (V_z H)}{1.57 b}$$

$$M_o = \frac{(0.01 \text{ kipft}) + ((-0.002 \text{ kip}) \times (0 \text{ ft}))}{1.57 \times (48 \text{ in})}$$

$$M_o = 0.0015924 \text{ kipft/ft}$$

Required depth of embedment in earth:

$$L_z^3 - \left(14.14 \times \frac{H_o \times L_z}{R}\right) - \left(18.85 \times \frac{M_o}{R}\right) = 0$$

Solving the cubic equation:

$L_{e,z} = 0.49019 \text{ ft}$  - Required depth in z-direction,

**Minimum embedded depth required:**

$L_{e,req}$  - Depth of pile required,

$$L_{e,req} = \text{MAX}[L_{e,x}, L_{e,z}]$$

$$L_{e,req} = \text{MAX}[(7.2378 \text{ ft}), (0.49019 \text{ ft})]$$

$$L_{e,req} = 7.238 \text{ ft}$$

$L_e$  - Actual embedded length of pile,

$$L_e = L - h_e - h_2$$

$$L_e = (7.75 \text{ ft}) - (0 \text{ ft}) - (0 \text{ ft})$$

$$L_e = 7.75 \text{ ft}$$

**Ratio** - Embedded depth

$$\text{Ratio} = \frac{L_{e,req}}{L_e}$$

$$\text{Ratio} = \frac{(7.238 \text{ ft})}{(7.75 \text{ ft})}$$

$$\text{Ratio} = 0.93394$$

Status: **PASS**  
Ratio: **0.930**

**End-bearing Capacity (ASD)**

A - Pile cross-section area

$$A = b D$$

$$A = (48 \text{ in}) \times (48 \text{ in})$$

$$A = 16 \text{ ft}^2$$

q - End-bearing pressure

$$q = \frac{P_c}{A}$$

$$q = \frac{(8.653 \text{ kip})}{(16 \text{ ft}^2)}$$

$$q = 0.54081 \text{ kip/ft}^2$$

$$q = 0.00001 \text{ kip/ft}$$

**Check bearing capacity ratio:**

Ratio - Capacity

$$\text{Ratio} = \frac{q}{q_a}$$

$$\text{Ratio} = \frac{(0.54081 \text{ kip/ft}^2)}{(2000 \text{ psf})}$$

$$\text{Ratio} = 0.27041$$

Status: **PASS**  
Ratio: **0.270**

Czerniak

**Lateral Soil Pressure (ASD):**

$L/D$  - Length to least lateral dimension ratio,

$$L/D = \frac{L}{D}$$

$$L/D = \frac{(7.75 \text{ ft})}{(48 \text{ in})}$$

$$L/D = 1.9375$$

Since  $L/D \leq 10$ ,

Pile is short.

**Considering x-direction:**

$H_o = -0.41322 \text{ kip/ft}$  - Lateral force per length of pile,

$M_o = 6.9825 \text{ kipft/ft}$  - Overturning moment per length of pile,

$a$  - Distance from resting surface to pivot point,

$$a = \frac{(4 M_o L_e) + (3 H_o L_e^2)}{(6 M_o) + (4 H_o L_e)}$$

$$a = \frac{(4 \times (6.9825 \text{ kipft/ft}) \times (7.75 \text{ ft})) + (3 \times (-0.41322 \text{ kip/ft}) \times (7.75 \text{ ft})^2)}{(6 \times (6.9825 \text{ kipft/ft})) + (4 \times (-0.41322 \text{ kip/ft}) \times (7.75 \text{ ft}))}$$

$$a = 5.3179 \text{ ft}$$

$p$  - Earth pressure against the pile at distance  $a/2$  from resting surface,

$$p = \frac{0.75 [(4 M_o) + (3 H_o L_e)]^2}{L_e^2 [(3 M_o) + (2 H_o L_e)]}$$

$$p = \frac{0.75 \times [(4 \times (6.9825 \text{ kipft/ft})) + (3 \times (-0.41322 \text{ kip/ft}) \times (7.75 \text{ ft}))]^2}{(7.75 \text{ ft})^2 \times [(3 \times (6.9825 \text{ kipft/ft})) + (2 \times (-0.41322 \text{ kip/ft}) \times (7.75 \text{ ft}))]}$$

$$p = 0.28827 \text{ kip/ft}^2$$

$s$  - Earth pressure against the pile at distance  $L_e$ ,

$$s = \frac{6 [(2 M_o) + (H_o L_e)]}{L_e^2}$$

$$s = \frac{6 \times [(2 \times (6.9825 \text{ kipft/ft})) + ((-0.41322 \text{ kip/ft}) \times (7.75 \text{ ft}))]}{(7.75 \text{ ft})^2}$$

$$s = 1.0751 \text{ kip/ft}^2$$

**Check lateral soil pressure capacity:**

$p_a$  - Allowable lateral soil pressure at depth  $a/2$ ,

$$p_a = R \frac{a}{2}$$

$$p_a = (150 \text{ psf/ft}) \times \frac{(5.3179 \text{ ft})}{2}$$

$$p_a = 0.39884 \text{ kip/ft}^2$$

Ratio - Lateral soil capacity

$$\text{Ratio} = \frac{p}{p_a}$$

$$\text{Ratio} = \frac{(0.28827 \text{ kip/ft}^2)}{(0.39884 \text{ kip/ft}^2)}$$

$$\text{Ratio} = 0.72276$$

$p_a$  - Allowable lateral soil pressure at depth  $L_e$ ,

Status: **PASS**  
Ratio: **0.720**

	$p_s = R L_e$ $p_s = (150 \text{ psf/ft}) \times (7.75 \text{ ft})$ $p_s = 1.1625 \text{ kip/ft}^2$ <p>Ratio - Lateral soil capacity</p> $\text{Ratio} = \frac{s}{p_s}$ $\text{Ratio} = \frac{(1.0751 \text{ kip/ft}^2)}{(1.1625 \text{ kip/ft}^2)}$ $\text{Ratio} = 0.92485$	Status: <b>PASS</b> Ratio: <b>0.920</b>
	<p><b>Considering z-direction:</b></p> <p><math>H_o = -0.00031847 \text{ kip/ft}</math> - Lateral force per length of pile,  <math>M_o = 0.0015924 \text{ kipft/ft}</math> - Overturning moment per length of pile,  <math>a</math> - Distance from resting surface to pivot point,</p> $a = \frac{(4 M_o L_e) + (3 H_o L_e^2)}{(6 M_o) + (4 H_o L_e)}$ $a = \frac{(4 \times (0.0015924 \text{ kipft/ft}) \times (7.75 \text{ ft})) + (3 \times (-0.00031847 \text{ kip/ft}) \times (7.75 \text{ ft})^2)}{(6 \times (0.0015924 \text{ kipft/ft})) + (4 \times (-0.00031847 \text{ kip/ft}) \times (7.75 \text{ ft}))}$ $a = 5.4949 \text{ ft}$ <p><math>p</math> - Earth pressure against the pile at distance <math>a/2</math> from resting surface,</p> $p = \frac{0.75 [(4 M_o) + (3 H_o L_e)]^2}{L_e^2 [(3 M_o) + (2 H_o L_e)]}$ $p = \frac{0.75 \times [(4 \times (0.0015924 \text{ kipft/ft})) + (3 \times (-0.00031847 \text{ kip/ft}) \times (7.75 \text{ ft}))]^2}{(7.75 \text{ ft})^2 \times [(3 \times (0.0015924 \text{ kipft/ft})) + (2 \times (-0.00031847 \text{ kip/ft}) \times (7.75 \text{ ft}))]}$ $p = -0.000084009 \text{ kip/ft}^2$ <p><math>s</math> - Earth pressure against the pile at distance <math>L_e</math>,</p> $s = \frac{6 [(2 M_o) + (H_o L_e)]}{L_e^2}$ $s = \frac{6 \times [(2 \times (0.0015924 \text{ kipft/ft})) + ((-0.00031847 \text{ kip/ft}) \times (7.75 \text{ ft}))]}{(7.75 \text{ ft})^2}$ $s = 0.000071581 \text{ kip/ft}^2$ <p><b>Check lateral soil pressure capacity:</b></p> <p><math>p_a</math> - Allowable lateral soil pressure at depth <math>a/2</math>,</p> $p_a = R \frac{a}{2}$ $p_a = (150 \text{ psf/ft}) \times \frac{(5.4949 \text{ ft})}{2}$ $p_a = 0.41212 \text{ kip/ft}^2$ <p>Ratio - Lateral soil capacity</p> $\text{Ratio} = \frac{p}{p_a}$ $\text{Ratio} = \frac{(-0.000084009 \text{ kip/ft}^2)}{(0.41212 \text{ kip/ft}^2)}$ $\text{Ratio} = -0.00020385$ <p><math>p_s</math> - Allowable lateral soil pressure at depth <math>L_e</math>,</p> $p_s = R L_e$ $p_s = (150 \text{ psf/ft}) \times (7.75 \text{ ft})$ $p_s = 1.1625 \text{ kip/ft}^2$ <p>Ratio - Lateral soil capacity</p> $\text{Ratio} = \frac{s}{p_s}$	Status: <b>PASS</b> Ratio: <b>0.000</b>

$$Ratio = \frac{(0.000071581 \text{ kip/ft}^2)}{(1.1625 \text{ kip/ft}^2)}$$

$$Ratio = 0.000061575$$

Status: **PASS**  
Ratio: **0.000**



#### Shear force and Bending moment (x-direction, LRFD)

$H_o$  - Lateral force per length of pile,

$$H_o = \frac{V_x}{1.57 D}$$

$$H_o = \frac{(-4.331 \text{ kip})}{1.57 \times (48 \text{ in})}$$

$$H_o = -0.68965 \text{ kip/ft}$$

$M_o$  - Moment per length of pile,

$$M_o = \frac{M_x + (V_x H)}{1.57 D}$$

$$M_o = \frac{(74.586 \text{ kipft}) + ((-4.331 \text{ kip}) \times (0 \text{ ft}))}{1.57 \times (48 \text{ in})}$$

$$M_o = 11.877 \text{ kipft/ft}$$

$E$  - Distance from lateral load to resisting surface,

$$E = \frac{M_o}{H_o}$$

$$E = \frac{(11.877 \text{ kipft/ft})}{(-0.68965 \text{ kip/ft})}$$

$$E = 17.221 \text{ ft}$$

$a$  - Distance from resting surface to pivot point,

$$a = \frac{(4 M_o L_c) + (3 H_o L_c^2)}{(6 M_o) + (4 H_o L_c)}$$

$$a = \frac{(4 \times (11.877 \text{ kipft/ft}) \times (7.75 \text{ ft})) + (3 \times (-0.68965 \text{ kip/ft}) \times (7.75 \text{ ft})^2)}{(6 \times (11.877 \text{ kipft/ft})) + (4 \times (-0.68965 \text{ kip/ft}) \times (7.75 \text{ ft}))}$$

$$a = 5.3157 \text{ ft}$$

$V_{max}$  - Max shear force located at depth  $a$ ,

$$V_{max} = (H_o D) \left[ 1 - \left[ 3 \left( \frac{4 E}{L_c} + 3 \right) \left( \frac{a}{L_c} \right)^2 \right] + \left[ 4 \left( \frac{3 E}{L_c} + 2 \right) \left( \frac{a}{L_c} \right)^3 \right] \right]$$

$$V_{max} = ((-0.68965 \text{ kip/ft}) \times (48 \text{ in})) \times \left[ 1 - \left[ 3 \times \left( \frac{4 \times (17.221 \text{ ft})}{(7.75 \text{ ft})} + 3 \right) \times \left( \frac{(5.3157 \text{ ft})}{(7.75 \text{ ft})} \right)^2 \right] + \left[ 4 \times \left( \frac{3 \times (17.221 \text{ ft})}{(7.75 \text{ ft})} + 2 \right) \times \left( \frac{(5.3157 \text{ ft})}{(7.75 \text{ ft})} \right)^3 \right] \right]$$

$$V_{max} = 12.67 \text{ kip}$$

$M_{max}$  - Max bending moment located at depth  $a/2$ ,

$$M_{max} = (H_o D L_e) \left[ \left( \frac{E}{L_e} + \frac{a}{2 L_e} \right) - \left[ \left( \frac{4E}{L_e} + 3 \right) \left( \frac{a}{2 L_e} \right)^3 \right] + \left[ \left( \frac{3E}{L_e} + 2 \right) \left( \frac{a}{2 L_e} \right)^4 \right] \right]$$

$$M_{max} = ((-0.68965 \text{ kip/ft}) \times (48 \text{ in}) \times (7.75 \text{ ft})) \times \left[ \left( \frac{(17.221 \text{ ft})}{(7.75 \text{ ft})} + \frac{(5.3157 \text{ ft})}{2 \times (7.75 \text{ ft})} \right) - \left[ \left( \frac{4 \times (17.221 \text{ ft})}{(7.75 \text{ ft})} + 3 \right) \times \left( \frac{(5.3157 \text{ ft})}{2 \times (7.75 \text{ ft})} \right)^3 \right] + \left[ \left( \frac{3 \times (17.221 \text{ ft})}{(7.75 \text{ ft})} + 2 \right) \times \left( \frac{(5.3157 \text{ ft})}{2 \times (7.75 \text{ ft})} \right)^4 \right] \right]$$

$$M_{max} = 47.15 \text{ kipft}$$

### Shear force and Bending moment (z-direction, LRFD)

$H_o$  - Lateral force per length of pile,

$$H_o = \frac{V_z}{1.57 b}$$

$$H_o = \frac{(-0.003 \text{ kip})}{1.57 \times (48 \text{ in})}$$

$$H_o = -0.00047771 \text{ kip/ft}$$

$M_o$  - Moment per length of pile,

$$M_o = \frac{M_x + (V_z H)}{1.57 b}$$

$$M_o = \frac{(0.016 \text{ kipft}) + ((-0.003 \text{ kip}) \times (0 \text{ ft}))}{1.57 \times (48 \text{ in})}$$

$$M_o = 0.0025478 \text{ kipft/ft}$$

$E$  - Distance from lateral load to resisting surface,

$$E = \frac{M_o}{H_o}$$

$$E = \frac{(0.0025478 \text{ kipft/ft})}{(-0.00047771 \text{ kip/ft})}$$

$$E = 5.3333 \text{ ft}$$

$a$  - Distance from resting surface to pivot point,

$$a = \frac{(4 M_o L_e) + (3 H_o L_e^2)}{(6 M_o) + (4 H_o L_e)}$$

$$a = \frac{(4 \times (0.0025478 \text{ kipft/ft}) \times (7.75 \text{ ft})) + (3 \times (-0.00047771 \text{ kip/ft}) \times (7.75 \text{ ft})^2)}{(6 \times (0.0025478 \text{ kipft/ft})) + (4 \times (-0.00047771 \text{ kip/ft}) \times (7.75 \text{ ft}))}$$

$$a = 5.4845 \text{ ft}$$

$V_{max}$  - Max shear force located at depth  $a$ ,

$$V_{max} = (H_o b) \left[ 1 - \left[ 3 \left( \frac{4E}{L_e} + 3 \right) \left( \frac{a}{L_e} \right)^2 \right] + \left[ 4 \left( \frac{3E}{L_e} + 2 \right) \left( \frac{a}{L_e} \right)^3 \right] \right]$$

$$V_{max} = ((-0.00047771 \text{ kip/ft}) \times (48 \text{ in})) \times \left[ 1 - \left[ 3 \times \left( \frac{4 \times (5.3333 \text{ ft})}{(7.75 \text{ ft})} + 3 \right) \times \left( \frac{(5.4845 \text{ ft})}{(7.75 \text{ ft})} \right)^2 \right] + \left[ 4 \times \left( \frac{3 \times (5.3333 \text{ ft})}{(7.75 \text{ ft})} + 2 \right) \times \left( \frac{(5.4845 \text{ ft})}{(7.75 \text{ ft})} \right)^3 \right] \right]$$

$$V_{max} = 0.0035942 \text{ kip}$$

$M_{max}$  - Max bending moment located at depth  $a/2$ ,

$$M_{max} = (H_o b L_e) \left[ \left( \frac{E}{L_e} + \frac{a}{2 L_e} \right) - \left[ \left( \frac{4E}{L_e} + 3 \right) \left( \frac{a}{2 L_e} \right)^3 \right] + \left[ \left( \frac{3E}{L_e} + 2 \right) \left( \frac{a}{2 L_e} \right)^4 \right] \right]$$

$$M_{max} = ((-0.00047771 \text{ kip/ft}) \times (48 \text{ in}) \times (7.75 \text{ ft})) \times \left[ \left( \frac{(5.3333 \text{ ft})}{(7.75 \text{ ft})} + \frac{(5.4845 \text{ ft})}{2 \times (7.75 \text{ ft})} \right) - \left[ \left( \frac{4 \times (5.3333 \text{ ft})}{(7.75 \text{ ft})} + 3 \right) \times \left( \frac{(5.4845 \text{ ft})}{2 \times (7.75 \text{ ft})} \right)^3 \right] + \left[ \left( \frac{3 \times (5.3333 \text{ ft})}{(7.75 \text{ ft})} + 2 \right) \times \left( \frac{(5.4845 \text{ ft})}{2 \times (7.75 \text{ ft})} \right)^4 \right] \right]$$

$$M_{max} = 0.012601 \text{ kipft}$$

### Minimum Reinforcement Check (LRFD)

#### Parameters:

$f'_{ck} = 2.5 \text{ ksi}$  - Concrete strength,  
 $f_{yk} = 60 \text{ ksi}$  - Longitudinal reinforcement strength,  
 $\phi = 0.65$  - Reduction factor for axial strength,  
 $\alpha = 0.8$  - Alpha factor for axial strength,  
 $A_g = 2304 \text{ in}^2$  - Gross area of concrete,

Table 22.4.2.1

#### Longitudinal reinforcement:

Required reinforcement due to axial load,  $A_{st,required}$

22.4.2.2, 10.6.1.1

$A_{st,required}$

$$A_{st,required} = \text{Min} \left[ \frac{\frac{P}{\phi \alpha} - (0.85 f'_{ck} A_g)}{f_{yk} - (0.85 f'_{ck})}, (0.08 A_g) \right]$$

$$A_{st,required} = \text{Min} \left[ \frac{\frac{(14.321 \text{ kip})}{(0.65) \times (0.8)} - (0.85 \times (2.5 \text{ ksi}) \times (2304 \text{ in}^2))}{(60 \text{ ksi}) - (0.85 \times (2.5 \text{ ksi}))}, (0.08 \times (2304 \text{ in}^2)) \right]$$

$$A_{st,required} = -84.12 \text{ in}^2$$

$A_{min}$  - Governing minimum reinforcement area,

$$A_{min} = \text{Max} [A_{st,required}, (0.0018 A_g)]$$

$$A_{min} = \text{Max} [(-84.12 \text{ in}^2), (0.0018 \times (2304 \text{ in}^2))]$$

$$A_{min} = 4.1472 \text{ in}^2$$

$n_{rebar}$  - Required number of reinforcement,

$$n_{rebar} = \frac{A_{min}}{A_{rebar}}$$

$$n_{rebar} = \frac{(4.1472 \text{ in}^2)}{(0.3068 \text{ in}^2)}$$

$$n_{rebar} = 14$$

$A_{st}$  - Actual total reinforcement area,

$$A_{st} = n_{rebar} \frac{\pi d_{bar}^2}{4}$$

$$A_{st} = (14) \times \frac{\pi \times (0.625 \text{ in})^2}{4}$$

$$A_{st} = 4.2951 \text{ in}^2$$

Ratio - Capacity

$$\text{Ratio} = \frac{A_{min}}{A_{st}}$$

$$\text{Ratio} = \frac{(4.1472 \text{ in}^2)}{(4.2951 \text{ in}^2)}$$

$$\text{Ratio} = 0.96556$$

Status: **PASS**  
Ratio: **0.970**

25.2.3

$s_{rebar}$  - Minimum spacing of reinforcement,

$$s_{rebar} = \text{Max} [1.5, (1.5 d_{bar})]$$

$$s_{rebar} = \text{Max} [1.5, (1.5 \times (0.625 \text{ in}))]$$

$$s_{rebar} = 1.5 \text{ in}$$

#### Ties:

25.7.2.2 Since longitudinal reinforcement is  $\leq$  No. 10: Use #3(0.375 in)

25.7.2.1  $s_{ties}$  - Maximum spacing of ties,

$$s_{ties} = \text{Min} [(16 d_{bar}), (48 d_{ties}), \text{Min} (D, b)]$$

$$s_{ties} = \text{Min} [(16 \times (0.625 \text{ in})), (48 \times (0.375 \text{ in})), \text{Min} ((48 \text{ in}), (48 \text{ in}))]$$

$$s_{ties} = 10 \text{ in}$$

#### Summary:

Main reinforcement: **14 - #5 (0.625 in)**

Ties: #3(0.375 in) - 10 in

**Axial Compression Strength (ACI 318-19, LRFD)**

22.4.2.2

$\phi P_N$  - Allowable axial compressive strength

$$\phi P_N = \phi 0.80 [(0.85 f'_{ck} [A_g - A_{st}]) + (f_{yk} A_{st})]$$

$$\phi P_N = (0.65) \times 0.80 \times [(0.85 \times (2.5 \text{ ksi}) \times [(2304 \text{ in}^2) - (4.2951 \text{ in}^2)]) + ((60 \text{ ksi}) \times (4.2951 \text{ in}^2))]$$

$$\phi P_N = 2675.2 \text{ kip}$$

Ratio - Capacity

$$\text{Ratio} = \frac{P}{\phi P_N}$$

$$\text{Ratio} = \frac{(14.321 \text{ kip})}{(2675.2 \text{ kip})}$$

$$\text{Ratio} = 0.0053533$$

Status: **PASS**  
Ratio: **0.010**

**Shear Strength (ACI 318-19, LRFD)**

**Parameters:**

22.5.2.2

$b_w = 48 \text{ in}$  - Effective width,  
 $d$  - Effective depth

$$d = 0.80 D$$

$$d = 0.80 \times (48 \text{ in})$$

$$d = 38.4 \text{ in}$$

22.5.5.1.3

$\lambda_s$  - size effect modification factor

$$\lambda_s = \text{MIN} \left[ \sqrt{\frac{2}{1 + \frac{d}{10}}}, 1 \right]$$

$$\lambda_s = \text{MIN} \left[ \sqrt{\frac{2}{1 + \frac{(38.4 \text{ in})}{10}}}, 1 \right]$$

$$\lambda_s = 0.64282$$

22.5.5.1.1

The following variables were converted to be consistent with empirical formula  $f'_{ck} = 2.5 \text{ ksi} \rightarrow 2500 \text{ psi}$ ,  
 $V_{c,max}$  - Max shear strength of concrete

$$V_{c,max} = 5 \lambda_s \sqrt{f'_{ck}} b_w d$$

$$V_{c,max} = 5 \times (0.64282) \times \sqrt{(2500 \text{ psi})} \times (48 \text{ in}) \times (38.4 \text{ in})$$

$$V_{c,max} = 296.21 \text{ kip}$$

22.5.5.1.1(a)

The following variables were converted to be consistent with empirical formula  $f'_{ck} = 2.5 \text{ ksi} \rightarrow 2500 \text{ psi}$ ,  $P = 14.321 \text{ kip} \rightarrow 14321 \text{ lbf}$ ,  
 $V_{c,a}$  - Shear strength of concrete (a)

$$V_{c,a} = \left[ 2 \lambda_s \sqrt{f'_{ck}} + \frac{P}{6 A_g} \right] b_w d$$

$$V_{c,a} = \left[ 2 \times (0.64282) \times \sqrt{(2500 \text{ psi})} + \frac{(14321 \text{ lbf})}{6 \times (2304 \text{ in}^2)} \right] \times (48 \text{ in}) \times (38.4 \text{ in})$$

$$V_{c,a} = 120.39 \text{ kip}$$

22.5.5.1.2

The following variables were converted to be consistent with empirical formula  $f'_{ck} = 2.5 \text{ ksi} \rightarrow 2500 \text{ psi}$ ,  
 $V_{c,b}$  - Shear strength of concrete (b)

$$V_{c,b} = \left[ 2 \lambda_s \sqrt{f'_{ck}} + (0.05 f'_{ck}) \right] b_w d$$

$$V_{c,b} = \left[ 2 \times (0.64282) \times \sqrt{(2500 \text{ psi})} + (0.05 \times (2500 \text{ psi})) \right] \times (48 \text{ in}) \times (38.4 \text{ in})$$

$$V_{c,b} = 348.89 \text{ kip}$$

$V_c$  - Governing shear strength of concrete

$$V_c = \text{Min}[V_{c,max}, V_{c,a}, V_{c,b}]$$

$$V_c = \text{Min}[(296.21 \text{ kip}), (120.39 \text{ kip}), (348.89 \text{ kip})]$$

$$V_c = 120.39 \text{ kip}$$

<p>22.5.1.2</p>	<p>The following variables were converted to be consistent with empirical formula <math>f'_{ck} = 2.5 \text{ ksi} \rightarrow 2500 \text{ psi}</math>.</p> <p><math>V_{s,a}</math> - Shear strength of steel (a)</p> $V_{s,a} = 8 \sqrt{f'_{ck}} b_w d$ $V_{s,a} = 8 \times \sqrt{(2500 \text{ psi})} \times (48 \text{ in}) \times (38.4 \text{ in})$ $V_{s,a} = 737.28 \text{ kip}$ <p><math>A_v</math> - Ties rebar area,</p> $A_v = \frac{\pi d_{ties}^2}{4}$ $A_v = \frac{\pi \times (0.375 \text{ in})^2}{4}$ $A_v = 0.11045 \text{ in}^2$ <p>22.5.8.5.3 <math>V_{s,b}</math> - Shear strength of steel (b)</p> $V_{s,b} = \frac{2 A_v f_{yt} d}{s_{ties}}$ $V_{s,b} = \frac{2 \times (0.11045 \text{ in}^2) \times (60 \text{ ksi}) \times (38.4 \text{ in})}{(10 \text{ in})}$ $V_{s,b} = 50.894 \text{ kip}$ <p><math>V_s</math> - Governing shear strength of steel</p> $V_s = \text{MIN}[V_{s,a}, V_{s,b}]$ $V_s = \text{MIN}[(737.28 \text{ kip}), (50.894 \text{ kip})]$ $V_s = 50.894 \text{ kip}$ <p>22.5.1.1 <math>\phi V_n</math> - Allowable shear strength</p> $\phi V_n = \phi (V_c + V_s)$ $\phi V_n = (0.65) \times ((120.39 \text{ kip}) + (50.894 \text{ kip}))$ $\phi V_n = 111.34 \text{ kip}$ <p><b>Considering x-direction:</b></p> <p><math>V_{max} = 12.67 \text{ kip}</math> - Maximum shear force in the x-direction,  Ratio - Capacity</p> $\text{Ratio} = \frac{V_{max}}{\phi V_n}$ $\text{Ratio} = \frac{(12.67 \text{ kip})}{(111.34 \text{ kip})}$ $\text{Ratio} = 0.1138$ <p><b>Considering z-direction:</b></p> <p><math>V_{max} = 0.0035942 \text{ kip}</math> - Maximum shear force in the z-direction,  Ratio - Capacity</p> $\text{Ratio} = \frac{V_{max}}{\phi V_n}$ $\text{Ratio} = \frac{(0.0035942 \text{ kip})}{(111.34 \text{ kip})}$ $\text{Ratio} = 0.000032282$	<p>Status: <b>PASS</b>  Ratio: <b>0.110</b></p> <p>Status: <b>PASS</b>  Ratio: <b>0.000</b></p>
	<p><b>Flexural Strength (ACI 318-19, LRFD)</b></p> <p><math>S_m</math> - Section modulus</p> $S_m = \frac{b D^2}{6}$ $S_m = \frac{(48 \text{ in}) \times (48 \text{ in})^2}{6}$ $S_m = 18432 \text{ in}^3$	

<p>14.5.2.1b</p>	<p><math>\lambda = 1</math> - Concrete modification factor (Normal concrete),  Allowable flexural strength:  <math>M_n</math> shall be the lesser of:  <math>\phi M_{n,1}</math></p> $\phi M_{n,1} = \phi \times 5 \times \lambda \times \sqrt{f'_c} \times S_m$ $\phi M_{n,1} = 0.65 \times 5 \times 1 \times \sqrt{2.5 \text{ksi}} \times 18432.001 \text{in}^3$ $\phi M_{n,1} = 249.600 \text{kipft}$ <p><math>\phi M_{n,2}</math></p> $\phi M_{n,2} = \phi \times 0.85 \times f'_c \times S_m$ $\phi M_{n,2} = (0.65) \times 0.85 \times (2.5 \text{ksi}) \times (18432 \text{in}^3)$ $\phi M_{n,2} = 2121.6 \text{kipft}$ <p>Therefore,  <math>\phi M_n</math> - Allowable flexural strength,</p> $\phi M_n = \text{MIN}[\phi M_{n,1}, \phi M_{n,2}]$ $\phi M_n = \text{MIN}[(249.6 \text{kipft}), (2121.6 \text{kipft})]$ $\phi M_n = 249.6 \text{kipft}$ <p><b>Considering x-direction:</b>  <math>M_{max} = 47.15 \text{kipft}</math> - Maximum moment in the x-direction,  Ratio - Capacity</p> $\text{Ratio} = \frac{M_{max}}{\phi M_n}$ $\text{Ratio} = \frac{(47.15 \text{kipft})}{(249.6 \text{kipft})}$ $\text{Ratio} = 0.1889$	<p>Status: <b>PASS</b>  Ratio: <b>0.190</b></p>
	<p><b>Considering z-direction:</b>  <math>M_{max} = 0.012601 \text{kipft}</math> - Maximum moment in the z-direction,  Ratio - Capacity</p> $\text{Ratio} = \frac{M_{max}}{\phi M_n}$ $\text{Ratio} = \frac{(0.012601 \text{kipft})}{(249.6 \text{kipft})}$ $\text{Ratio} = 0.000050483$	<p>Status: <b>PASS</b>  Ratio: <b>0.000</b></p>

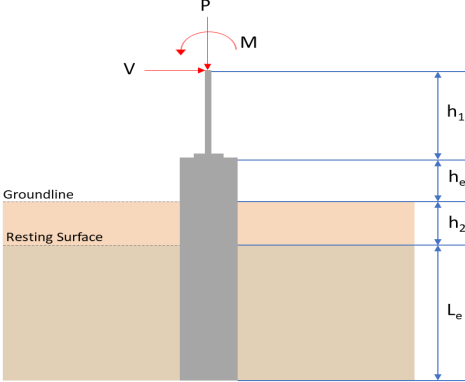
REFERENCES	CALCULATIONS	RESULTS																										
	<p><b>SkyCiv Foundation Design</b> Pile Foundation</p> <p><b>Design Information :</b> Design code : IBC 2021 (International Building Code) Unit System : Imperial</p>																											
	<p><b>Pile Input</b></p>  <p><b>Geometry</b> Pile shape: rectangular <math>b = 48</math> in - Pile width <math>D = 48</math> in - Pile depth <math>L = 7.75</math> ft - Total pile length <math>h_1 = 0</math> ft - Lateral load height from the top of the pile, <math>h_2 = 0</math> ft - Depth to resting surface <math>h_e = 0</math> ft - Length of pile above the ground</p> <p><b>Tabulation of Soil Parameters</b></p> <table border="1" data-bbox="416 1102 1193 1193"> <thead> <tr> <th>Layer</th> <th>Label</th> <th>Allowable Bearing Pressure (<math>q_a</math>) (psf)</th> <th>Allowable Lateral Pressure (<math>R</math>) (psf/ft)</th> </tr> </thead> <tbody> <tr> <td>1</td> <td>Sand, silty sand, clayey sand, silty gravel &amp; clayey gravel</td> <td>2000.000</td> <td>150.000</td> </tr> </tbody> </table> <p><b>Tabulation of Loads</b></p> <table border="1" data-bbox="676 1288 935 1458"> <thead> <tr> <th>Load Component</th> <th>ASD</th> <th>LRFD</th> </tr> </thead> <tbody> <tr> <td><math>P</math> (kip)</td> <td>9.077</td> <td>14.983</td> </tr> <tr> <td><math>V_x</math> (kip)</td> <td>-2.622</td> <td>-4.379</td> </tr> <tr> <td><math>V_z</math> (kip)</td> <td>0.000</td> <td>0.000</td> </tr> <tr> <td><math>M_x</math> (kipft)</td> <td>0.000</td> <td>0.000</td> </tr> <tr> <td><math>M_z</math> (kipft)</td> <td>44.053</td> <td>74.623</td> </tr> </tbody> </table> <p><b>Material Properties</b> <math>f'_{ck} = 2.5</math> ksi - Concrete strength,</p>	Layer	Label	Allowable Bearing Pressure ( $q_a$ ) (psf)	Allowable Lateral Pressure ( $R$ ) (psf/ft)	1	Sand, silty sand, clayey sand, silty gravel & clayey gravel	2000.000	150.000	Load Component	ASD	LRFD	$P$ (kip)	9.077	14.983	$V_x$ (kip)	-2.622	-4.379	$V_z$ (kip)	0.000	0.000	$M_x$ (kipft)	0.000	0.000	$M_z$ (kipft)	44.053	74.623	
Layer	Label	Allowable Bearing Pressure ( $q_a$ ) (psf)	Allowable Lateral Pressure ( $R$ ) (psf/ft)																									
1	Sand, silty sand, clayey sand, silty gravel & clayey gravel	2000.000	150.000																									
Load Component	ASD	LRFD																										
$P$ (kip)	9.077	14.983																										
$V_x$ (kip)	-2.622	-4.379																										
$V_z$ (kip)	0.000	0.000																										
$M_x$ (kipft)	0.000	0.000																										
$M_z$ (kipft)	44.053	74.623																										
	<p><b>Required depth to resist lateral loads (ASD)</b> <math>H</math> - Point of application of the lateral load</p> $H = h_1 + h_2 + h_e$ $H = (0 \text{ ft}) + (0 \text{ ft}) + (0 \text{ ft})$ $H = 0 \text{ ft}$ <p><b>Considering x-direction:</b> <math>H_o</math> - Lateral force per length of pile,</p> $H_o = \frac{V_x}{1.57 D}$ $H_o = \frac{(-2.622 \text{ kip})}{1.57 \times (48 \text{ in})}$ $H_o = -0.41752 \text{ kip/ft}$ <p><math>M_o</math> - Moment per length of pile,</p> $M_o = \frac{M_z + (V_x H)}{1.57 D}$																											

$$M_o = \frac{(44.053 \text{ kipft}) + ((-2.622 \text{ kip}) \times (0 \text{ ft}))}{1.57 \times (48 \text{ in})}$$

$$M_o = 7.0148 \text{ kipft/ft}$$

Required depth of embedment in earth:

$$L_x^3 - \left(14.14 \times \frac{H_o \times L_x}{R}\right) - \left(18.85 \times \frac{M_o}{R}\right) = 0$$

Solving the cubic equation:

$$L_{e,x} = 7.2417 \text{ ft} - \text{Required depth in x-direction,}$$

**Considering z-direction:**

$$L_{e,z} = 0 \text{ ft} - \text{Required depth in z-direction,}$$

**Minimum embedded depth required:**

$L_{e,req}$  - Depth of pile required,

$$L_{e,req} = \text{MAX}[L_{e,x}, L_{e,z}]$$

$$L_{e,req} = \text{MAX}[(7.2417 \text{ ft}), (0 \text{ ft})]$$

$$L_{e,req} = 7.242 \text{ ft}$$

$L_e$  - Actual embedded length of pile,

$$L_e = L - h_e - h_2$$

$$L_e = (7.75 \text{ ft}) - (0 \text{ ft}) - (0 \text{ ft})$$

$$L_e = 7.75 \text{ ft}$$

**Ratio** - Embedded depth

$$\text{Ratio} = \frac{L_{e,req}}{L_e}$$

$$\text{Ratio} = \frac{(7.242 \text{ ft})}{(7.75 \text{ ft})}$$

$$\text{Ratio} = 0.93445$$

Status: **PASS**  
Ratio: **0.930**

### End-bearing Capacity (ASD)

A - Pile cross-section area

$$A = b D$$

$$A = (48 \text{ in}) \times (48 \text{ in})$$

$$A = 16 \text{ ft}^2$$

q - End-bearing pressure

$$q = \frac{P_v}{A}$$

$$q = \frac{(9.077 \text{ kip})}{(16 \text{ ft}^2)}$$

$$q = 0.56731 \text{ kip/ft}^2$$

**Check bearing capacity ratio:**

**Ratio** - Capacity

$$\text{Ratio} = \frac{q}{q_o}$$

$$\text{Ratio} = \frac{(0.56731 \text{ kip/ft}^2)}{(2000 \text{ psf})}$$

$$\text{Ratio} = 0.28366$$

Status: **PASS**  
Ratio: **0.280**

Czerniak

### Lateral Soil Pressure (ASD):

L/D - Length to least lateral dimension ratio,

$$L/D = \frac{L}{D}$$

$$L/D = \frac{(7.75 \text{ ft})}{(48 \text{ in})}$$

$$L/D = 1.9375$$

Since  $L/D \leq 10$ ,

Pile is short.

**Considering x-direction:**

$H_o = -0.41752$  kip/ft - Lateral force per length of pile,

$M_o = 7.0148$  kipft/ft - Overturning moment per length of pile,

$a$  - Distance from resting surface to pivot point,

$$a = \frac{(4 M_o L_e) + (3 H_o L_e^2)}{(6 M_o) + (4 H_o L_e)}$$

$$a = \frac{(4 \times (7.0148 \text{ kipft/ft}) \times (7.75 \text{ ft})) + (3 \times (-0.41752 \text{ kip/ft}) \times (7.75 \text{ ft})^2)}{(6 \times (7.0148 \text{ kipft/ft})) + (4 \times (-0.41752 \text{ kip/ft}) \times (7.75 \text{ ft}))}$$

$$a = 5.3186 \text{ ft}$$

$p$  - Earth pressure against the pile at distance  $a/2$  from resting surface,

$$p = \frac{0.75 [(4 M_o) + (3 H_o L_e)]^2}{L_e^2 [(3 M_o) + (2 H_o L_e)]}$$

$$p = \frac{0.75 [(4 \times (7.0148 \text{ kipft/ft})) + (3 \times (-0.41752 \text{ kip/ft}) \times (7.75 \text{ ft}))]^2}{(7.75 \text{ ft})^2 [(3 \times (7.0148 \text{ kipft/ft})) + (2 \times (-0.41752 \text{ kip/ft}) \times (7.75 \text{ ft}))]}$$

$$p = 0.28859 \text{ kip/ft}^2$$

$s$  - Earth pressure against the pile at distance  $L_e$ ,

$$s = \frac{6 [(2 M_o) + (H_o L_e)]}{L_e^2}$$

$$s = \frac{6 [(2 \times (7.0148 \text{ kipft/ft})) + ((-0.41752 \text{ kip/ft}) \times (7.75 \text{ ft}))]}{(7.75 \text{ ft})^2}$$

$$s = 1.0783 \text{ kip/ft}^2$$

**Check lateral soil pressure capacity:**

$p_a$  - Allowable lateral soil pressure at depth  $a/2$ ,

$$p_a = R \frac{a}{2}$$

$$p_a = (150 \text{ psf/ft}) \times \frac{(5.3186 \text{ ft})}{2}$$

$$p_a = 0.39889 \text{ kip/ft}^2$$

*Ratio* - Lateral soil capacity

$$\text{Ratio} = \frac{p}{p_a}$$

$$\text{Ratio} = \frac{(0.28859 \text{ kip/ft}^2)}{(0.39889 \text{ kip/ft}^2)}$$

$$\text{Ratio} = 0.72347$$

$p_s$  - Allowable lateral soil pressure at depth  $L_e$ ,

$$p_s = R L_e$$

$$p_s = (150 \text{ psf/ft}) \times (7.75 \text{ ft})$$

$$p_s = 1.1625 \text{ kip/ft}^2$$

*Ratio* - Lateral soil capacity

$$\text{Ratio} = \frac{s}{p_s}$$

$$\text{Ratio} = \frac{(1.0783 \text{ kip/ft}^2)}{(1.1625 \text{ kip/ft}^2)}$$

$$\text{Ratio} = 0.92754$$

Status: **PASS**  
Ratio: **0.720**

Status: **PASS**  
Ratio: **0.930**

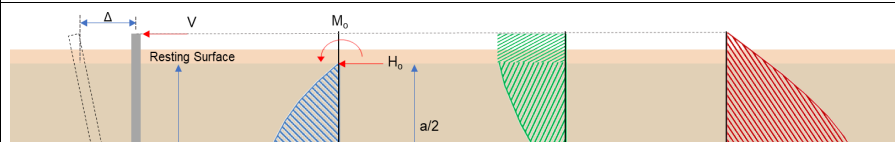

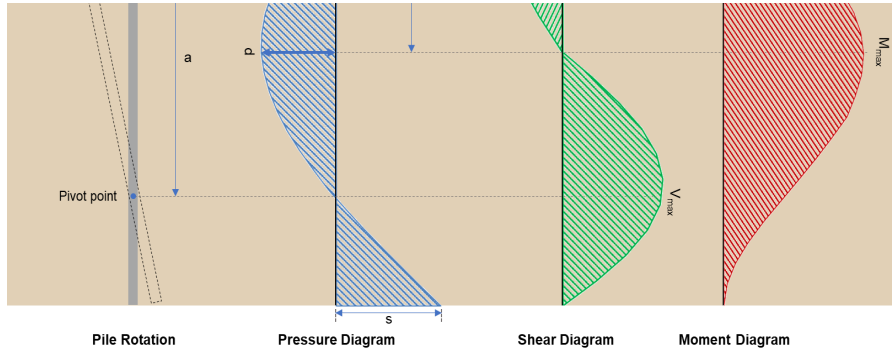

### Shear force and Bending moment (x-direction, LRFD)

$H_o$  - Lateral force per length of pile,

$$H_o = \frac{V_x}{1.57 D}$$

$$H_o = \frac{(-4.379 \text{ kip})}{1.57 \times (48 \text{ in})}$$

$$H_o = -0.69729 \text{ kip/ft}$$

$M_o$  - Moment per length of pile,

$$M_o = \frac{M_x + (V_x H)}{1.57 D}$$

$$M_o = \frac{(74.623 \text{ kipft}) + ((-4.379 \text{ kip}) \times (0 \text{ ft}))}{1.57 \times (48 \text{ in})}$$

$$M_o = 11.883 \text{ kipft/ft}$$

$E$  - Distance from lateral load to resisting surface,

$$E = \frac{M_o}{H_o}$$

$$E = \frac{(11.883 \text{ kipft/ft})}{(-0.69729 \text{ kip/ft})}$$

$$E = 17.041 \text{ ft}$$

$a$  - Distance from resting surface to pivot point,

$$a = \frac{(4 M_o L_c) + (3 H_o L_c^2)}{(6 M_o) + (4 H_o L_c)}$$

$$a = \frac{(4 \times (11.883 \text{ kipft/ft}) \times (7.75 \text{ ft})) + (3 \times (-0.69729 \text{ kip/ft}) \times (7.75 \text{ ft})^2)}{(6 \times (11.883 \text{ kipft/ft})) + (4 \times (-0.69729 \text{ kip/ft}) \times (7.75 \text{ ft}))}$$

$$a = 5.3169 \text{ ft}$$

$V_{max}$  - Max shear force located at depth  $a$ ,

$$V_{max} = (H_o D) \left[ 1 - \left[ 3 \left( \frac{4 E}{L_c} + 3 \right) \left( \frac{a}{L_c} \right)^2 \right] + \left[ 4 \left( \frac{3 E}{L_c} + 2 \right) \left( \frac{a}{L_c} \right)^3 \right] \right]$$

$$V_{max} = ((-0.69729 \text{ kip/ft}) \times (48 \text{ in})) \times \left[ 1 - \left[ 3 \times \left( \frac{4 \times (17.041 \text{ ft})}{(7.75 \text{ ft})} + 3 \right) \times \left( \frac{(5.3169 \text{ ft})}{(7.75 \text{ ft})} \right)^2 \right] + \left[ 4 \times \left( \frac{3 \times (17.041 \text{ ft})}{(7.75 \text{ ft})} + 2 \right) \times \left( \frac{(5.3169 \text{ ft})}{(7.75 \text{ ft})} \right)^3 \right] \right]$$

$$V_{max} = 12.696 \text{ kip}$$

$M_{max}$  - Max bending moment located at depth  $a/2$ ,

$$M_{max} = (H_o D L_c) \left[ \left( \frac{E}{L_c} + \frac{a}{2 L_c} \right) - \left[ \left( \frac{4 E}{L_c} + 3 \right) \left( \frac{a}{2 L_c} \right)^3 \right] + \left[ \left( \frac{3 E}{L_c} + 2 \right) \left( \frac{a}{2 L_c} \right)^4 \right] \right]$$

$$M_{max} = ((-0.69729 \text{ kip/ft}) \times (48 \text{ in}) \times (7.75 \text{ ft})) \times \left[ \left( \frac{(17.041 \text{ ft})}{(7.75 \text{ ft})} + \frac{(5.3169 \text{ ft})}{2 \times (7.75 \text{ ft})} \right) - \left[ \left( \frac{4 \times (17.041 \text{ ft})}{(7.75 \text{ ft})} + 3 \right) \times \left( \frac{(5.3169 \text{ ft})}{2 \times (7.75 \text{ ft})} \right)^3 \right] + \left[ \left( \frac{3 \times (17.041 \text{ ft})}{(7.75 \text{ ft})} + 2 \right) \times \left( \frac{(5.3169 \text{ ft})}{2 \times (7.75 \text{ ft})} \right)^4 \right] \right]$$

$$M_{max} = 47.227 \text{ kipft}$$

### Minimum Reinforcement Check (LRFD)

#### Parameters:

$f'_{ck} = 2.5 \text{ ksi}$  - Concrete strength,  
 $f_{yk} = 60 \text{ ksi}$  - Longitudinal reinforcement strength,  
 $\phi = 0.65$  - Reduction factor for axial strength,  
 $\alpha = 0.8$  - Alpha factor for axial strength,  
 $A_g = 2304 \text{ in}^2$  - Gross area of concrete,

Table 22.4.2.1

#### Longitudinal reinforcement:

Required reinforcement due to axial load,  $A_{st,required}$

22.4.2.2, 10.6.1.1

$A_{st,required}$

$$A_{st,required} = \text{Min} \left[ \frac{\frac{P}{\phi \alpha} - (0.85 f'_{ck} A_g)}{f_{yk} - (0.85 f'_{ck})}, (0.08 A_g) \right]$$

$$A_{st,required} = \text{Min} \left[ \frac{\frac{(14.983 \text{ kip})}{(0.65) \times (0.8)} - (0.85 \times (2.5 \text{ ksi}) \times (2304 \text{ in}^2))}{(60 \text{ ksi}) - (0.85 \times (2.5 \text{ ksi}))}, (0.08 \times (2304 \text{ in}^2)) \right]$$

$$A_{st,required} = -84.098 \text{ in}^2$$

$A_{min}$  - Governing minimum reinforcement area,

$$A_{min} = \text{Max} [A_{st,required}, (0.0018 A_g)]$$

$$A_{min} = \text{Max} [(-84.098 \text{ in}^2), (0.0018 \times (2304 \text{ in}^2))]$$

$$A_{min} = 4.1472 \text{ in}^2$$

$n_{rebar}$  - Required number of reinforcement,

$$n_{rebar} = \frac{A_{min}}{A_{rebar}}$$

$$n_{rebar} = \frac{(4.1472 \text{ in}^2)}{(0.3068 \text{ in}^2)}$$

$$n_{rebar} = 14$$

$A_{st}$  - Actual total reinforcement area,

$$A_{st} = n_{rebar} \frac{\pi d_{bar}^2}{4}$$

$$A_{st} = (14) \times \frac{\pi \times (0.625 \text{ in})^2}{4}$$

$$A_{st} = 4.2951 \text{ in}^2$$

Ratio - Capacity

$$\text{Ratio} = \frac{A_{min}}{A_{st}}$$

$$\text{Ratio} = \frac{(4.1472 \text{ in}^2)}{(4.2951 \text{ in}^2)}$$

$$\text{Ratio} = 0.96556$$

Status: **PASS**  
Ratio: **0.970**

25.2.3  $s_{rebar}$  - Minimum spacing of reinforcement,

$$s_{rebar} = \text{Max} [1.5, (1.5 d_{bar})]$$

$$s_{rebar} = \text{Max} [1.5, (1.5 \times (0.625 \text{ in}))]$$

$$s_{rebar} = 1.5 \text{ in}$$

#### Ties:

25.7.2.2 Since longitudinal reinforcement is  $\leq$  No. 10: Use #3(0.375 in)

25.7.2.1  $s_{ties}$  - Maximum spacing of ties,

$$s_{ties} = \text{Min} [(16 d_{bar}), (48 d_{ties}), \text{Min} (D, b)]$$

$$s_{ties} = \text{Min} [(16 \times (0.625 \text{ in})), (48 \times (0.375 \text{ in})), \text{Min} ((48 \text{ in}), (48 \text{ in}))]$$

$$s_{ties} = 10 \text{ in}$$

#### Summary:

Main reinforcement: **14 - #5 (0.625 in)**

**Axial Compression Strength (ACI 318-19, LRFD)**22.4.2.2  $\phi P_N$  - Allowable axial compressive strength

$$\phi P_N = \phi 0.80 [(0.85 f'_{ck} [A_g - A_{st}] + (f_{yk} A_{st})]$$

$$\phi P_N = (0.65) \times 0.80 \times [(0.85 \times (2.5 \text{ ksi}) \times [(2304 \text{ in}^2) - (4.2951 \text{ in}^2)]) + ((60 \text{ ksi}) \times (4.2951 \text{ in}^2))]$$

$$\phi P_N = 2675.2 \text{ kip}$$

Ratio - Capacity

$$\text{Ratio} = \frac{P}{\phi P_N}$$

$$\text{Ratio} = \frac{(14.983 \text{ kip})}{(2675.2 \text{ kip})}$$

$$\text{Ratio} = 0.0056007$$

Status: **PASS**  
Ratio: **0.010****Shear Strength (ACI 318-19, LRFD)****Parameters:** $b_w = 48 \text{ in}$  - Effective width,22.5.2.2  $d$  - Effective depth

$$d = 0.80 D$$

$$d = 0.80 \times (48 \text{ in})$$

$$d = 38.4 \text{ in}$$

22.5.5.1.3  $\lambda_s$  - size effect modification factor

$$\lambda_s = \text{MIN} \left[ \sqrt{\frac{2}{1 + \frac{d}{10}}}, 1 \right]$$

$$\lambda_s = \text{MIN} \left[ \sqrt{\frac{2}{1 + \frac{(38.4 \text{ in})}{10}}}, 1 \right]$$

$$\lambda_s = 0.64282$$

The following variables were converted to be consistent with empirical formula  $f'_{ck} = 2.5 \text{ ksi} \rightarrow 2500 \text{ psi}$ ,22.5.5.1.1  $V_{c,max}$  - Max shear strength of concrete

$$V_{c,max} = 5 \lambda_s \sqrt{f'_{ck}} b_w d$$

$$V_{c,max} = 5 \times (0.64282) \times \sqrt{(2500 \text{ psi})} \times (48 \text{ in}) \times (38.4 \text{ in})$$

$$V_{c,max} = 296.21 \text{ kip}$$

The following variables were converted to be consistent with empirical formula  $f'_{ck} = 2.5 \text{ ksi} \rightarrow 2500 \text{ psi}$ ,  $P = 14.983 \text{ kip} \rightarrow 14983 \text{ lbf}$ ,22.5.5.1.1(a)  $V_{c,a}$  - Shear strength of concrete (a)

$$V_{c,a} = \left[ 2 \lambda_s \sqrt{f'_{ck}} + \frac{P}{6 A_g} \right] b_w d$$

$$V_{c,a} = \left[ 2 \times (0.64282) \times \sqrt{(2500 \text{ psi})} + \frac{(14983 \text{ lbf})}{6 \times (2304 \text{ in}^2)} \right] \times (48 \text{ in}) \times (38.4 \text{ in})$$

$$V_{c,a} = 120.48 \text{ kip}$$

The following variables were converted to be consistent with empirical formula  $f'_{ck} = 2.5 \text{ ksi} \rightarrow 2500 \text{ psi}$ ,22.5.5.1.2  $V_{c,b}$  - Shear strength of concrete (b)

$$V_{c,b} = \left[ 2 \lambda_s \sqrt{f'_{ck}} + (0.05 f'_{ck}) \right] b_w d$$

$$V_{c,b} = \left[ 2 \times (0.64282) \times \sqrt{(2500 \text{ psi})} + (0.05 \times (2500 \text{ psi})) \right] \times (48 \text{ in}) \times (38.4 \text{ in})$$

$$V_{c,b} = 348.89 \text{ kip}$$

 $V_c$  - Governing shear strength of concrete

$$V_c = \text{Min}[V_{c,max}, V_{c,a}, V_{c,b}]$$

$$V_c = \text{Min}[(296.21 \text{ kip}), (120.48 \text{ kip}), (348.89 \text{ kip})]$$

$$V_c = 120.48 \text{ kip}$$

<p>22.5.1.2</p>	<p>The following variables were converted to be consistent with empirical formula <math>f'_{ck} = 2.5 \text{ ksi} \rightarrow 2500 \text{ psi}</math>,</p> <p><math>V_{s,a}</math> - Shear strength of steel (a)</p> $V_{s,a} = 8 \sqrt{f'_{ck}} b_w d$ $V_{s,a} = 8 \times \sqrt{(2500 \text{ psi})} \times (48 \text{ in}) \times (38.4 \text{ in})$ $V_{s,a} = 737.28 \text{ kip}$ <p><math>A_v</math> - Ties rebar area,</p> $A_v = \frac{\pi d_{ties}^2}{4}$ $A_v = \frac{\pi \times (0.375 \text{ in})^2}{4}$ $A_v = 0.11045 \text{ in}^2$ <p>22.5.8.5.3 <math>V_{s,b}</math> - Shear strength of steel (b)</p> $V_{s,b} = \frac{2 A_v f_{yw} d}{s_{ties}}$ $V_{s,b} = \frac{2 \times (0.11045 \text{ in}^2) \times (60 \text{ ksi}) \times (38.4 \text{ in})}{(10 \text{ in})}$ $V_{s,b} = 50.894 \text{ kip}$ <p><math>V_s</math> - Governing shear strength of steel</p> $V_s = \text{MIN}[V_{s,a}, V_{s,b}]$ $V_s = \text{MIN}[(737.28 \text{ kip}), (50.894 \text{ kip})]$ $V_s = 50.894 \text{ kip}$ <p>22.5.1.1 <math>\phi V_n</math> - Allowable shear strength</p> $\phi V_n = \phi (V_c + V_s)$ $\phi V_n = (0.65) \times ((120.48 \text{ kip}) + (50.894 \text{ kip}))$ $\phi V_n = 111.39 \text{ kip}$ <p><b>Considering x-direction:</b></p> <p><math>V_{max} = 12.696 \text{ kip}</math> - Maximum shear force in the x-direction,  <b>Ratio</b> - Capacity</p> $\text{Ratio} = \frac{V_{max}}{\phi V_n}$ $\text{Ratio} = \frac{(12.696 \text{ kip})}{(111.39 \text{ kip})}$ $\text{Ratio} = 0.11397$	<p>Status: <b>PASS</b>  Ratio: <b>0.110</b></p>
<p>14.5.2.1b</p>	<p><b>Flexural Strength (ACI 318-19, LRFD)</b></p> <p><math>S_m</math> - Section modulus</p> $S_m = \frac{b D^2}{6}$ $S_m = \frac{(48 \text{ in}) \times (48 \text{ in})^2}{6}$ $S_m = 18432 \text{ in}^3$ <p><math>\lambda = 1</math> - Concrete modification factor (Normal concrete),  Allowable flexural strength:  <math>M_n</math> shall be the lesser of:</p> <p><math>\phi M_{n,1}</math></p> $\phi M_{n,1} = \phi \times 5 \times \lambda \times \sqrt{f'_c} \times S_m$ $\phi M_{n,1} = 0.65 \times 5 \times 1 \times \sqrt{(2.5 \text{ ksi})} \times 18432.001 \text{ in}^3$ $\phi M_{n,1} = 249.600 \text{ kip ft}$ <p><math>\phi M_{n,2}</math></p> $\phi M_{n,2} = \phi \times 0.85 \times f'_c \times S_m$	

$$\phi M_{n,2} = \phi S_x F_y$$

$$\phi M_{n,2} = (0.65) \times 0.85 \times (2.5 \text{ ksi}) \times (18432 \text{ in}^3)$$

$$\phi M_{n,2} = 2121.6 \text{ kipft}$$

Therefore,

$\phi M_n$  - Allowable flexural strength,

$$\phi M_n = \text{MIN}[\phi M_{n,1}, \phi M_{n,2}]$$

$$\phi M_n = \text{MIN}[(249.6 \text{ kipft}), (2121.6 \text{ kipft})]$$

$$\phi M_n = 249.6 \text{ kipft}$$

**Considering x-direction:**

$M_{max} = 47.227 \text{ kipft}$  - Maximum moment in the x-direction,

*Ratio* - Capacity

$$\text{Ratio} = \frac{M_{max}}{\phi M_n}$$

$$\text{Ratio} = \frac{(47.227 \text{ kipft})}{(249.6 \text{ kipft})}$$

$$\text{Ratio} = 0.18921$$

Status: **PASS**  
Ratio: **0.190**

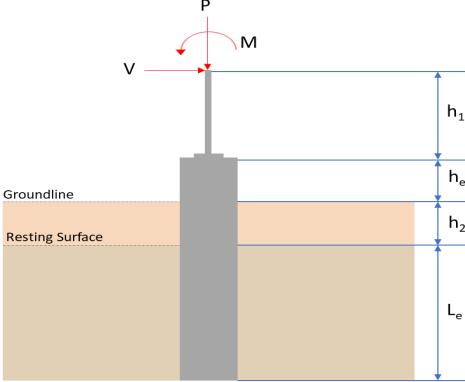
REFERENCES	CALCULATIONS	RESULTS																										
	<p><b>SkyCiv Foundation Design</b> Pile Foundation</p> <p><b>Design Information :</b> Design code : IBC 2021 (International Building Code) Unit System : Imperial</p>																											
	<p><b>Pile Input</b></p>  <p><b>Geometry</b></p> <p>Pile shape: rectangular  <math>b = 48</math> in - Pile width  <math>D = 48</math> in - Pile depth  <math>L = 7.75</math> ft - Total pile length  <math>h_1 = 0</math> ft - Lateral load height from the top of the pile,  <math>h_2 = 0</math> ft - Depth to resting surface  <math>h_e = 0</math> ft - Length of pile above the ground</p> <p><b>Tabulation of Soil Parameters</b></p> <table border="1" data-bbox="416 1102 1193 1191"> <thead> <tr> <th>Layer</th> <th>Label</th> <th>Allowable Bearing Pressure (<math>q_a</math>) (psf)</th> <th>Allowable Lateral Pressure (<math>R</math>) (psf/ft)</th> </tr> </thead> <tbody> <tr> <td>1</td> <td>Sand, silty sand, clayey sand, silty gravel &amp; clayey gravel</td> <td>2000.000</td> <td>150.000</td> </tr> </tbody> </table> <p><b>Tabulation of Loads</b></p> <table border="1" data-bbox="676 1288 933 1458"> <thead> <tr> <th>Load Component</th> <th>ASD</th> <th>LRFD</th> </tr> </thead> <tbody> <tr> <td><math>P</math> (kip)</td> <td>8.653</td> <td>14.321</td> </tr> <tr> <td><math>V_x</math> (kip)</td> <td>-2.595</td> <td>-4.331</td> </tr> <tr> <td><math>V_z</math> (kip)</td> <td>0.002</td> <td>0.003</td> </tr> <tr> <td><math>M_x</math> (kipft)</td> <td>-0.010</td> <td>-0.016</td> </tr> <tr> <td><math>M_z</math> (kipft)</td> <td>43.850</td> <td>74.587</td> </tr> </tbody> </table> <p><b>Material Properties</b></p> <p><math>f'_{ck} = 2.5</math> ksi - Concrete strength,</p>	Layer	Label	Allowable Bearing Pressure ( $q_a$ ) (psf)	Allowable Lateral Pressure ( $R$ ) (psf/ft)	1	Sand, silty sand, clayey sand, silty gravel & clayey gravel	2000.000	150.000	Load Component	ASD	LRFD	$P$ (kip)	8.653	14.321	$V_x$ (kip)	-2.595	-4.331	$V_z$ (kip)	0.002	0.003	$M_x$ (kipft)	-0.010	-0.016	$M_z$ (kipft)	43.850	74.587	
Layer	Label	Allowable Bearing Pressure ( $q_a$ ) (psf)	Allowable Lateral Pressure ( $R$ ) (psf/ft)																									
1	Sand, silty sand, clayey sand, silty gravel & clayey gravel	2000.000	150.000																									
Load Component	ASD	LRFD																										
$P$ (kip)	8.653	14.321																										
$V_x$ (kip)	-2.595	-4.331																										
$V_z$ (kip)	0.002	0.003																										
$M_x$ (kipft)	-0.010	-0.016																										
$M_z$ (kipft)	43.850	74.587																										
	<p><b>Required depth to resist lateral loads (ASD)</b></p> <p><math>H</math> - Point of application of the lateral load</p> $H = h_1 + h_2 + h_e$ $H = (0 \text{ ft}) + (0 \text{ ft}) + (0 \text{ ft})$ $H = 0 \text{ ft}$ <p><b>Considering x-direction:</b></p> <p><math>H_o</math> - Lateral force per length of pile,</p> $H_o = \frac{V_x}{1.57 D}$ $H_o = \frac{(-2.595 \text{ kip})}{1.57 \times (48 \text{ in})}$ $H_o = -0.41322 \text{ kip/ft}$ <p><math>M_o</math> - Moment per length of pile,</p> $M_o = \frac{M_z + (V_x H)}{1.57 D}$																											

$$M_o = \frac{(43.85 \text{ kipft}) + ((-2.595 \text{ kip}) \times (0 \text{ ft}))}{1.57 \times (48 \text{ in})}$$

$$M_o = 6.9825 \text{ kipft/ft}$$

Required depth of embedment in earth:

$$L_x^3 - \left(14.14 \times \frac{H_o \times L_x}{R}\right) - \left(18.85 \times \frac{M_o}{R}\right) = 0$$

Solving the cubic equation:

$L_{e,x} = 7.2378 \text{ ft}$  - Required depth in x-direction,

**Considering z-direction:**

$H_o$  - Lateral force per length of pile,

$$H_o = \frac{V_z}{1.57 b}$$

$$H_o = \frac{(0.002 \text{ kip})}{1.57 \times (48 \text{ in})}$$

$$H_o = 0.00031847 \text{ kip/ft}$$

$M_o$  - Moment per length of pile,

$$M_o = \frac{M_x + (V_z H)}{1.57 b}$$

$$M_o = \frac{(0.01 \text{ kipft}) + ((0.002 \text{ kip}) \times (0 \text{ ft}))}{1.57 \times (48 \text{ in})}$$

$$M_o = 0.0015924 \text{ kipft/ft}$$

Required depth of embedment in earth:

$$L_z^3 - \left(14.14 \times \frac{H_o \times L_z}{R}\right) - \left(18.85 \times \frac{M_o}{R}\right) = 0$$

Solving the cubic equation:

$L_{e,z} = 0.51564 \text{ ft}$  - Required depth in z-direction,

**Minimum embedded depth required:**

$L_{e,req}$  - Depth of pile required,

$$L_{e,req} = \text{MAX}[L_{e,x}, L_{e,z}]$$

$$L_{e,req} = \text{MAX}[(7.2378 \text{ ft}), (0.51564 \text{ ft})]$$

$$L_{e,req} = 7.238 \text{ ft}$$

$L_e$  - Actual embedded length of pile,

$$L_e = L - h_e - h_2$$

$$L_e = (7.75 \text{ ft}) - (0 \text{ ft}) - (0 \text{ ft})$$

$$L_e = 7.75 \text{ ft}$$

**Ratio** - Embedded depth

$$\text{Ratio} = \frac{L_{e,req}}{L_e}$$

$$\text{Ratio} = \frac{(7.238 \text{ ft})}{(7.75 \text{ ft})}$$

$$\text{Ratio} = 0.93394$$

Status: **PASS**  
Ratio: **0.930**

**End-bearing Capacity (ASD)**

A - Pile cross-section area

$$A = b D$$

$$A = (48 \text{ in}) \times (48 \text{ in})$$

$$A = 16 \text{ ft}^2$$

q - End-bearing pressure

$$q = \frac{P_c}{A}$$

$$q = \frac{(8.653 \text{ kip})}{(16 \text{ ft}^2)}$$

$$q = 0.54081 \text{ kip/ft}^2$$

$$q = 0.04081 \text{ kip/ft}^2$$

**Check bearing capacity ratio:**

Ratio - Capacity

$$\text{Ratio} = \frac{q}{q_a}$$

$$\text{Ratio} = \frac{(0.54081 \text{ kip/ft}^2)}{(2000 \text{ psf})}$$

$$\text{Ratio} = 0.27041$$

Status: **PASS**  
Ratio: **0.270**

Czerniak

**Lateral Soil Pressure (ASD):**

$L/D$  - Length to least lateral dimension ratio,

$$L/D = \frac{L}{D}$$

$$L/D = \frac{(7.75 \text{ ft})}{(48 \text{ in})}$$

$$L/D = 1.9375$$

Since  $L/D \leq 10$ ,

Pile is short.

**Considering x-direction:**

$H_o = -0.41322 \text{ kip/ft}$  - Lateral force per length of pile,

$M_o = 6.9825 \text{ kipft/ft}$  - Overturning moment per length of pile,

$a$  - Distance from resting surface to pivot point,

$$a = \frac{(4 M_o L_e) + (3 H_o L_e^2)}{(6 M_o) + (4 H_o L_e)}$$

$$a = \frac{(4 \times (6.9825 \text{ kipft/ft}) \times (7.75 \text{ ft})) + (3 \times (-0.41322 \text{ kip/ft}) \times (7.75 \text{ ft})^2)}{(6 \times (6.9825 \text{ kipft/ft})) + (4 \times (-0.41322 \text{ kip/ft}) \times (7.75 \text{ ft}))}$$

$$a = 5.3179 \text{ ft}$$

$p$  - Earth pressure against the pile at distance  $a/2$  from resting surface,

$$p = \frac{0.75 [(4 M_o) + (3 H_o L_e)]^2}{L_e^2 [(3 M_o) + (2 H_o L_e)]}$$

$$p = \frac{0.75 \times [(4 \times (6.9825 \text{ kipft/ft})) + (3 \times (-0.41322 \text{ kip/ft}) \times (7.75 \text{ ft}))]^2}{(7.75 \text{ ft})^2 \times [(3 \times (6.9825 \text{ kipft/ft})) + (2 \times (-0.41322 \text{ kip/ft}) \times (7.75 \text{ ft}))]}$$

$$p = 0.28827 \text{ kip/ft}^2$$

$s$  - Earth pressure against the pile at distance  $L_e$ ,

$$s = \frac{6 [(2 M_o) + (H_o L_e)]}{L_e^2}$$

$$s = \frac{6 \times [(2 \times (6.9825 \text{ kipft/ft})) + ((-0.41322 \text{ kip/ft}) \times (7.75 \text{ ft}))]}{(7.75 \text{ ft})^2}$$

$$s = 1.0751 \text{ kip/ft}^2$$

**Check lateral soil pressure capacity:**

$p_a$  - Allowable lateral soil pressure at depth  $a/2$ ,

$$p_a = R \frac{a}{2}$$

$$p_a = (150 \text{ psf/ft}) \times \frac{(5.3179 \text{ ft})}{2}$$

$$p_a = 0.39884 \text{ kip/ft}^2$$

Ratio - Lateral soil capacity

$$\text{Ratio} = \frac{p}{p_a}$$

$$\text{Ratio} = \frac{(0.28827 \text{ kip/ft}^2)}{(0.39884 \text{ kip/ft}^2)}$$

$$\text{Ratio} = 0.72276$$

$p_a$  - Allowable lateral soil pressure at depth  $L_e$ ,

Status: **PASS**  
Ratio: **0.720**

$$p_s = R L_e$$

$$p_s = (150 \text{ psf/ft}) \times (7.75 \text{ ft})$$

$$p_s = 1.1625 \text{ kip/ft}^2$$

Ratio - Lateral soil capacity

$$\text{Ratio} = \frac{s}{p_s}$$

$$\text{Ratio} = \frac{(1.0751 \text{ kip/ft}^2)}{(1.1625 \text{ kip/ft}^2)}$$

$$\text{Ratio} = 0.92485$$

Status: **PASS**  
Ratio: **0.920**

**Considering z-direction:**

$H_o = 0.00031847 \text{ kip/ft}$  - Lateral force per length of pile.

$M_o = 0.0015924 \text{ kipft/ft}$  - Overturning moment per length of pile.

$a$  - Distance from resting surface to pivot point.

$$a = \frac{(4 M_o L_e) + (3 H_o L_e^2)}{(6 M_o) + (4 H_o L_e)}$$

$$a = \frac{(4 \times (0.0015924 \text{ kipft/ft}) \times (7.75 \text{ ft})) + (3 \times (0.00031847 \text{ kip/ft}) \times (7.75 \text{ ft})^2)}{(6 \times (0.0015924 \text{ kipft/ft})) + (4 \times (0.00031847 \text{ kip/ft}) \times (7.75 \text{ ft}))}$$

$$a = 5.4949 \text{ ft}$$

$p$  - Earth pressure against the pile at distance  $a/2$  from resting surface.

$$p = \frac{0.75 [(4 M_o) + (3 H_o L_e)]^2}{L_e^2 [(3 M_o) + (2 H_o L_e)]}$$

$$p = \frac{0.75 \times [(4 \times (0.0015924 \text{ kipft/ft})) + (3 \times (0.00031847 \text{ kip/ft}) \times (7.75 \text{ ft}))]^2}{(7.75 \text{ ft})^2 \times [(3 \times (0.0015924 \text{ kipft/ft})) + (2 \times (0.00031847 \text{ kip/ft}) \times (7.75 \text{ ft}))]}$$

$$p = 0.00024389 \text{ kip/ft}^2$$

$s$  - Earth pressure against the pile at distance  $L_e$ .

$$s = \frac{6 [(2 M_o) + (H_o L_e)]}{L_e^2}$$

$$s = \frac{6 \times [(2 \times (0.0015924 \text{ kipft/ft})) + ((0.00031847 \text{ kip/ft}) \times (7.75 \text{ ft}))]}{(7.75 \text{ ft})^2}$$

$$s = 0.0005647 \text{ kip/ft}^2$$

**Check lateral soil pressure capacity:**

$p_a$  - Allowable lateral soil pressure at depth  $a/2$ ,

$$p_a = R \frac{a}{2}$$

$$p_a = (150 \text{ psf/ft}) \times \frac{(5.4949 \text{ ft})}{2}$$

$$p_a = 0.41212 \text{ kip/ft}^2$$

Ratio - Lateral soil capacity

$$\text{Ratio} = \frac{p}{p_a}$$

$$\text{Ratio} = \frac{(0.00024389 \text{ kip/ft}^2)}{(0.41212 \text{ kip/ft}^2)}$$

$$\text{Ratio} = 0.00059181$$

$p_s$  - Allowable lateral soil pressure at depth  $L_e$ .

$$p_s = R L_e$$

$$p_s = (150 \text{ psf/ft}) \times (7.75 \text{ ft})$$

$$p_s = 1.1625 \text{ kip/ft}^2$$

Ratio - Lateral soil capacity

$$\text{Ratio} = \frac{s}{p_s}$$

Status: **PASS**  
Ratio: **0.000**

$$\text{Ratio} = \frac{(0.0005647 \text{ kip/ft}^2)}{(1.1625 \text{ kip/ft}^2)}$$

$$\text{Ratio} = 0.00048576$$

Status: **PASS**  
Ratio: **0.000**

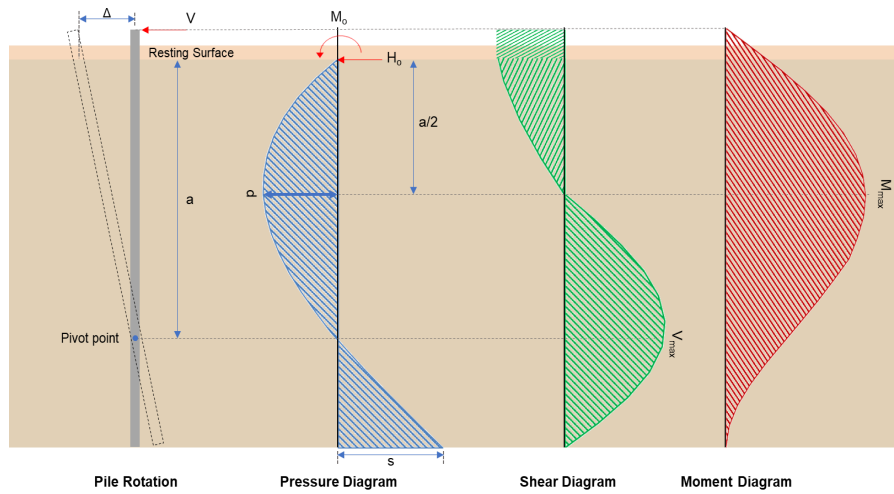

#### Shear force and Bending moment (x-direction, LRFD)

$H_o$  - Lateral force per length of pile,

$$H_o = \frac{V_x}{1.57 D}$$

$$H_o = \frac{(-4.331 \text{ kip})}{1.57 \times (48 \text{ in})}$$

$$H_o = -0.68965 \text{ kip/ft}$$

$M_o$  - Moment per length of pile,

$$M_o = \frac{M_x + (V_x H)}{1.57 D}$$

$$M_o = \frac{(74.587 \text{ kipft}) + ((-4.331 \text{ kip}) \times (0 \text{ ft}))}{1.57 \times (48 \text{ in})}$$

$$M_o = 11.877 \text{ kipft/ft}$$

$E$  - Distance from lateral load to resisting surface,

$$E = \frac{M_o}{H_o}$$

$$E = \frac{(11.877 \text{ kipft/ft})}{(-0.68965 \text{ kip/ft})}$$

$$E = 17.222 \text{ ft}$$

$a$  - Distance from resting surface to pivot point,

$$a = \frac{(4 M_o L_c) + (3 H_o L_c^2)}{(6 M_o) + (4 H_o L_c)}$$

$$a = \frac{(4 \times (11.877 \text{ kipft/ft}) \times (7.75 \text{ ft})) + (3 \times (-0.68965 \text{ kip/ft}) \times (7.75 \text{ ft})^2)}{(6 \times (11.877 \text{ kipft/ft})) + (4 \times (-0.68965 \text{ kip/ft}) \times (7.75 \text{ ft}))}$$

$$a = 5.3157 \text{ ft}$$

$V_{max}$  - Max shear force located at depth  $a$ ,

$$V_{max} = (H_o D) \left[ 1 - \left[ 3 \left( \frac{4 E}{L_c} + 3 \right) \left( \frac{a}{L_c} \right)^2 \right] + \left[ 4 \left( \frac{3 E}{L_c} + 2 \right) \left( \frac{a}{L_c} \right)^3 \right] \right]$$

$$V_{max} = ((-0.68965 \text{ kip/ft}) \times (48 \text{ in})) \times \left[ 1 - \left[ 3 \times \left( \frac{4 \times (17.222 \text{ ft})}{(7.75 \text{ ft})} + 3 \right) \times \left( \frac{(5.3157 \text{ ft})}{(7.75 \text{ ft})} \right)^2 \right] + \left[ 4 \times \left( \frac{3 \times (17.222 \text{ ft})}{(7.75 \text{ ft})} + 2 \right) \times \left( \frac{(5.3157 \text{ ft})}{(7.75 \text{ ft})} \right)^3 \right] \right]$$

$$V_{max} = 12.67 \text{ kip}$$

$M_{max}$  - Max bending moment located at depth  $a/2$ ,

$$M_{max} = (H_o D L_e) \left[ \left( \frac{E}{L_e} + \frac{a}{2 L_e} \right) - \left[ \left( \frac{4 E}{L_e} + 3 \right) \left( \frac{a}{2 L_e} \right)^3 \right] + \left[ \left( \frac{3 E}{L_e} + 2 \right) \left( \frac{a}{2 L_e} \right)^4 \right] \right]$$

$$M_{max} = ((-0.68965 \text{ kip/ft}) \times (48 \text{ in}) \times (7.75 \text{ ft})) \times \left[ \left( \frac{(17.222 \text{ ft})}{(7.75 \text{ ft})} + \frac{(5.3157 \text{ ft})}{2 \times (7.75 \text{ ft})} \right) - \left[ \left( \frac{4 \times (17.222 \text{ ft})}{(7.75 \text{ ft})} + 3 \right) \times \left( \frac{(5.3157 \text{ ft})}{2 \times (7.75 \text{ ft})} \right)^3 \right] + \left[ \left( \frac{3 \times (17.222 \text{ ft})}{(7.75 \text{ ft})} + 2 \right) \times \left( \frac{(5.3157 \text{ ft})}{2 \times (7.75 \text{ ft})} \right)^4 \right] \right]$$

$$M_{max} = 47.151 \text{ kipft}$$

### Shear force and Bending moment (z-direction, LRFD)

$H_o$  - Lateral force per length of pile,

$$H_o = \frac{V_z}{1.57 b}$$

$$H_o = \frac{(0.003 \text{ kip})}{1.57 \times (48 \text{ in})}$$

$$H_o = 0.00047771 \text{ kip/ft}$$

$M_o$  - Moment per length of pile,

$$M_o = \frac{M_x + (V_z H)}{1.57 b}$$

$$M_o = \frac{(0.016 \text{ kipft}) + ((0.003 \text{ kip}) \times (0 \text{ ft}))}{1.57 \times (48 \text{ in})}$$

$$M_o = 0.0025478 \text{ kipft/ft}$$

$E$  - Distance from lateral load to resisting surface,

$$E = \frac{M_o}{H_o}$$

$$E = \frac{(0.0025478 \text{ kipft/ft})}{(0.00047771 \text{ kip/ft})}$$

$$E = 5.3333 \text{ ft}$$

$a$  - Distance from resting surface to pivot point,

$$a = \frac{(4 M_o L_e) + (3 H_o L_e^2)}{(6 M_o) + (4 H_o L_e)}$$

$$a = \frac{(4 \times (0.0025478 \text{ kipft/ft}) \times (7.75 \text{ ft})) + (3 \times (0.00047771 \text{ kip/ft}) \times (7.75 \text{ ft})^2)}{(6 \times (0.0025478 \text{ kipft/ft})) + (4 \times (0.00047771 \text{ kip/ft}) \times (7.75 \text{ ft}))}$$

$$a = 5.4845 \text{ ft}$$

$V_{max}$  - Max shear force located at depth  $a$ ,

$$V_{max} = (H_o b) \left[ 1 - \left[ 3 \left( \frac{4 E}{L_e} + 3 \right) \left( \frac{a}{L_e} \right)^2 \right] + \left[ 4 \left( \frac{3 E}{L_e} + 2 \right) \left( \frac{a}{L_e} \right)^3 \right] \right]$$

$$V_{max} = ((0.00047771 \text{ kip/ft}) \times (48 \text{ in})) \times \left[ 1 - \left[ 3 \times \left( \frac{4 \times (5.3333 \text{ ft})}{(7.75 \text{ ft})} + 3 \right) \times \left( \frac{(5.4845 \text{ ft})}{(7.75 \text{ ft})} \right)^2 \right] + \left[ 4 \times \left( \frac{3 \times (5.3333 \text{ ft})}{(7.75 \text{ ft})} + 2 \right) \times \left( \frac{(5.4845 \text{ ft})}{(7.75 \text{ ft})} \right)^3 \right] \right]$$

$$V_{max} = 0.0035942 \text{ kip}$$

$M_{max}$  - Max bending moment located at depth  $a/2$ ,

$$M_{max} = (H_o b L_e) \left[ \left( \frac{E}{L_e} + \frac{a}{2 L_e} \right) - \left[ \left( \frac{4 E}{L_e} + 3 \right) \left( \frac{a}{2 L_e} \right)^3 \right] + \left[ \left( \frac{3 E}{L_e} + 2 \right) \left( \frac{a}{2 L_e} \right)^4 \right] \right]$$

$$M_{max} = ((0.00047771 \text{ kip/ft}) \times (48 \text{ in}) \times (7.75 \text{ ft})) \times \left[ \left( \frac{(5.3333 \text{ ft})}{(7.75 \text{ ft})} + \frac{(5.4845 \text{ ft})}{2 \times (7.75 \text{ ft})} \right) - \left[ \left( \frac{4 \times (5.3333 \text{ ft})}{(7.75 \text{ ft})} + 3 \right) \times \left( \frac{(5.4845 \text{ ft})}{2 \times (7.75 \text{ ft})} \right)^3 \right] + \left[ \left( \frac{3 \times (5.3333 \text{ ft})}{(7.75 \text{ ft})} + 2 \right) \times \left( \frac{(5.4845 \text{ ft})}{2 \times (7.75 \text{ ft})} \right)^4 \right] \right]$$

$$M_{max} = 0.012601 \text{ kipft}$$

### Minimum Reinforcement Check (LRFD)

#### Parameters:

$f'_{ck} = 2.5 \text{ ksi}$  - Concrete strength,  
 $f_{yk} = 60 \text{ ksi}$  - Longitudinal reinforcement strength,  
 $\phi = 0.65$  - Reduction factor for axial strength,  
 $\alpha = 0.8$  - Alpha factor for axial strength,  
 $A_g = 2304 \text{ in}^2$  - Gross area of concrete,

Table 22.4.2.1

#### Longitudinal reinforcement:

Required reinforcement due to axial load,  $A_{st,required}$

22.4.2.2, 10.6.1.1

$A_{st,required}$

$$A_{st,required} = \text{Min} \left[ \frac{\frac{P}{\phi \alpha} - (0.85 f'_{ck} A_g)}{f_{yk} - (0.85 f'_{ck})}, (0.08 A_g) \right]$$

$$A_{st,required} = \text{Min} \left[ \frac{\frac{(14.321 \text{ kip})}{(0.65) \times (0.8)} - (0.85 \times (2.5 \text{ ksi}) \times (2304 \text{ in}^2))}{(60 \text{ ksi}) - (0.85 \times (2.5 \text{ ksi}))}, (0.08 \times (2304 \text{ in}^2)) \right]$$

$$A_{st,required} = -84.12 \text{ in}^2$$

$A_{min}$  - Governing minimum reinforcement area,

$$A_{min} = \text{Max} [A_{st,required}, (0.0018 A_g)]$$

$$A_{min} = \text{Max} [(-84.12 \text{ in}^2), (0.0018 \times (2304 \text{ in}^2))]$$

$$A_{min} = 4.1472 \text{ in}^2$$

$n_{rebar}$  - Required number of reinforcement,

$$n_{rebar} = \frac{A_{min}}{A_{rebar}}$$

$$n_{rebar} = \frac{(4.1472 \text{ in}^2)}{(0.3068 \text{ in}^2)}$$

$$n_{rebar} = 14$$

$A_{st}$  - Actual total reinforcement area,

$$A_{st} = n_{rebar} \frac{\pi d_{bar}^2}{4}$$

$$A_{st} = (14) \times \frac{\pi \times (0.625 \text{ in})^2}{4}$$

$$A_{st} = 4.2951 \text{ in}^2$$

Ratio - Capacity

$$\text{Ratio} = \frac{A_{min}}{A_{st}}$$

$$\text{Ratio} = \frac{(4.1472 \text{ in}^2)}{(4.2951 \text{ in}^2)}$$

$$\text{Ratio} = 0.96556$$

Status: **PASS**  
Ratio: **0.970**

25.2.3  $s_{rebar}$  - Minimum spacing of reinforcement,

$$s_{rebar} = \text{Max} [1.5, (1.5 d_{bar})]$$

$$s_{rebar} = \text{Max} [1.5, (1.5 \times (0.625 \text{ in}))]$$

$$s_{rebar} = 1.5 \text{ in}$$

#### Ties:

25.7.2.2 Since longitudinal reinforcement is  $\leq$  No. 10: Use #3(0.375 in)

25.7.2.1  $s_{ties}$  - Maximum spacing of ties,

$$s_{ties} = \text{Min} [(16 d_{bar}), (48 d_{ties}), \text{Min} (D, b)]$$

$$s_{ties} = \text{Min} [(16 \times (0.625 \text{ in})), (48 \times (0.375 \text{ in})), \text{Min} ((48 \text{ in}), (48 \text{ in}))]$$

$$s_{ties} = 10 \text{ in}$$

#### Summary:

Main reinforcement: **14 - #5 (0.625 in)**

Ties: #3(0.375 in) - 10 in

**Axial Compression Strength (ACI 318-19, LRFD)**

22.4.2.2

$\phi P_N$  - Allowable axial compressive strength

$$\phi P_N = \phi 0.80 [(0.85 f'_{ck} [A_g - A_{st}]) + (f_{yk} A_{st})]$$

$$\phi P_N = (0.65) \times 0.80 \times [(0.85 \times (2.5 \text{ ksi}) \times [(2304 \text{ in}^2) - (4.2951 \text{ in}^2)]) + ((60 \text{ ksi}) \times (4.2951 \text{ in}^2))]$$

$$\phi P_N = 2675.2 \text{ kip}$$

Ratio - Capacity

$$\text{Ratio} = \frac{P}{\phi P_N}$$

$$\text{Ratio} = \frac{(14.321 \text{ kip})}{(2675.2 \text{ kip})}$$

$$\text{Ratio} = 0.0053533$$

Status: **PASS**  
Ratio: **0.010**

**Shear Strength (ACI 318-19, LRFD)**

**Parameters:**

22.5.2.2

$b_w = 48 \text{ in}$  - Effective width,  
 $d$  - Effective depth

$$d = 0.80 D$$

$$d = 0.80 \times (48 \text{ in})$$

$$d = 38.4 \text{ in}$$

22.5.5.1.3

$\lambda_s$  - size effect modification factor

$$\lambda_s = \text{MIN} \left[ \sqrt{\frac{2}{1 + \frac{d}{10}}}, 1 \right]$$

$$\lambda_s = \text{MIN} \left[ \sqrt{\frac{2}{1 + \frac{(38.4 \text{ in})}{10}}}, 1 \right]$$

$$\lambda_s = 0.64282$$

22.5.5.1.1

The following variables were converted to be consistent with empirical formula  $f'_{ck} = 2.5 \text{ ksi} \rightarrow 2500 \text{ psi}$ ,  
 $V_{c,max}$  - Max shear strength of concrete

$$V_{c,max} = 5 \lambda_s \sqrt{f'_{ck}} b_w d$$

$$V_{c,max} = 5 \times (0.64282) \times \sqrt{(2500 \text{ psi})} \times (48 \text{ in}) \times (38.4 \text{ in})$$

$$V_{c,max} = 296.21 \text{ kip}$$

22.5.5.1.1(a)

The following variables were converted to be consistent with empirical formula  $f'_{ck} = 2.5 \text{ ksi} \rightarrow 2500 \text{ psi}$ ,  $P = 14.321 \text{ kip} \rightarrow 14321 \text{ lbf}$ ,  
 $V_{c,a}$  - Shear strength of concrete (a)

$$V_{c,a} = \left[ 2 \lambda_s \sqrt{f'_{ck}} + \frac{P}{6 A_g} \right] b_w d$$

$$V_{c,a} = \left[ 2 \times (0.64282) \times \sqrt{(2500 \text{ psi})} + \frac{(14321 \text{ lbf})}{6 \times (2304 \text{ in}^2)} \right] \times (48 \text{ in}) \times (38.4 \text{ in})$$

$$V_{c,a} = 120.39 \text{ kip}$$

22.5.5.1.2

The following variables were converted to be consistent with empirical formula  $f'_{ck} = 2.5 \text{ ksi} \rightarrow 2500 \text{ psi}$ ,  
 $V_{c,b}$  - Shear strength of concrete (b)

$$V_{c,b} = \left[ 2 \lambda_s \sqrt{f'_{ck}} + (0.05 f'_{ck}) \right] b_w d$$

$$V_{c,b} = \left[ 2 \times (0.64282) \times \sqrt{(2500 \text{ psi})} + (0.05 \times (2500 \text{ psi})) \right] \times (48 \text{ in}) \times (38.4 \text{ in})$$

$$V_{c,b} = 348.89 \text{ kip}$$

$V_c$  - Governing shear strength of concrete

$$V_c = \text{Min}[V_{c,max}, V_{c,a}, V_{c,b}]$$

$$V_c = \text{Min}[(296.21 \text{ kip}), (120.39 \text{ kip}), (348.89 \text{ kip})]$$

$$V_c = 120.39 \text{ kip}$$

<p>22.5.1.2</p>	<p>The following variables were converted to be consistent with empirical formula <math>f'_{ck} = 2.5 \text{ ksi} \rightarrow 2500 \text{ psi}</math>.</p> <p><math>V_{s,a}</math> - Shear strength of steel (a)</p> $V_{s,a} = 8 \sqrt{f'_{ck}} b_w d$ $V_{s,a} = 8 \times \sqrt{(2500 \text{ psi})} \times (48 \text{ in}) \times (38.4 \text{ in})$ $V_{s,a} = 737.28 \text{ kip}$ <p><math>A_v</math> - Ties rebar area,</p> $A_v = \frac{\pi d_{ties}^2}{4}$ $A_v = \frac{\pi \times (0.375 \text{ in})^2}{4}$ $A_v = 0.11045 \text{ in}^2$ <p>22.5.8.5.3 <math>V_{s,b}</math> - Shear strength of steel (b)</p> $V_{s,b} = \frac{2 A_v f_{yt} d}{s_{ties}}$ $V_{s,b} = \frac{2 \times (0.11045 \text{ in}^2) \times (60 \text{ ksi}) \times (38.4 \text{ in})}{(10 \text{ in})}$ $V_{s,b} = 50.894 \text{ kip}$ <p><math>V_s</math> - Governing shear strength of steel</p> $V_s = \text{MIN}[V_{s,a}, V_{s,b}]$ $V_s = \text{MIN}[(737.28 \text{ kip}), (50.894 \text{ kip})]$ $V_s = 50.894 \text{ kip}$ <p>22.5.1.1 <math>\phi V_n</math> - Allowable shear strength</p> $\phi V_n = \phi (V_c + V_s)$ $\phi V_n = (0.65) \times ((120.39 \text{ kip}) + (50.894 \text{ kip}))$ $\phi V_n = 111.34 \text{ kip}$ <p><b>Considering x-direction:</b></p> <p><math>V_{max} = 12.67 \text{ kip}</math> - Maximum shear force in the x-direction, Ratio - Capacity</p> $\text{Ratio} = \frac{V_{max}}{\phi V_n}$ $\text{Ratio} = \frac{(12.67 \text{ kip})}{(111.34 \text{ kip})}$ $\text{Ratio} = 0.1138$ <p><b>Considering z-direction:</b></p> <p><math>V_{max} = 0.0035942 \text{ kip}</math> - Maximum shear force in the z-direction, Ratio - Capacity</p> $\text{Ratio} = \frac{V_{max}}{\phi V_n}$ $\text{Ratio} = \frac{(0.0035942 \text{ kip})}{(111.34 \text{ kip})}$ $\text{Ratio} = 0.000032282$	<p>Status: <b>PASS</b> Ratio: <b>0.110</b></p> <p>Status: <b>PASS</b> Ratio: <b>0.000</b></p>
	<p><b>Flexural Strength (ACI 318-19, LRFD)</b></p> <p><math>S_m</math> - Section modulus</p> $S_m = \frac{b D^2}{6}$ $S_m = \frac{(48 \text{ in}) \times (48 \text{ in})^2}{6}$ $S_m = 18432 \text{ in}^3$	

<p>14.5.2.1b</p>	<p><math>\lambda = 1</math> - Concrete modification factor (Normal concrete),          Allowable flexural strength:  <math>M_n</math> shall be the lesser of:  <math>\phi M_{n,1}</math></p> $\phi M_{n,1} = \phi \times 5 \times \lambda \times \sqrt{f'_c} \times S_m$ $\phi M_{n,1} = 0.65 \times 5 \times 1 \times \sqrt{2.5 \text{ksi}} \times 18432.001 \text{in}^3$ $\phi M_{n,1} = 249.600 \text{kipft}$ <p><math>\phi M_{n,2}</math></p> $\phi M_{n,2} = \phi \times 0.85 \times f'_c \times S_m$ $\phi M_{n,2} = (0.65) \times 0.85 \times (2.5 \text{ksi}) \times (18432 \text{in}^3)$ $\phi M_{n,2} = 2121.6 \text{kipft}$ <p>Therefore,  <math>\phi M_n</math> - Allowable flexural strength,</p> $\phi M_n = \text{MIN}[\phi M_{n,1}, \phi M_{n,2}]$ $\phi M_n = \text{MIN}[(249.6 \text{kipft}), (2121.6 \text{kipft})]$ $\phi M_n = 249.6 \text{kipft}$ <p><b>Considering x-direction:</b>  <math>M_{max} = 47.151 \text{kipft}</math> - Maximum moment in the x-direction,          Ratio - Capacity</p> $\text{Ratio} = \frac{M_{max}}{\phi M_n}$ $\text{Ratio} = \frac{(47.151 \text{kipft})}{(249.6 \text{kipft})}$ $\text{Ratio} = 0.1889$	<p>Status: <b>PASS</b>          Ratio: <b>0.190</b></p>
	<p><b>Considering z-direction:</b>  <math>M_{max} = 0.012601 \text{kipft}</math> - Maximum moment in the z-direction,          Ratio - Capacity</p> $\text{Ratio} = \frac{M_{max}}{\phi M_n}$ $\text{Ratio} = \frac{(0.012601 \text{kipft})}{(249.6 \text{kipft})}$ $\text{Ratio} = 0.000050483$	<p>Status: <b>PASS</b>          Ratio: <b>0.000</b></p>